

Lumistar Luminaire ASL57LED-Ex, Aluminium

CE 0158

3755.358 c

II 2G Ex d(e) IIC T6 Gb
II 2D Ex tb IIIC T80°C Db

- **For mounting on sight glass fittings**
 This Ex-type sight glass luminaire is designed for universal applications and is ideal for use in combined sight and light ports (single-flange version) or with two separate ports (2-flange version).
- **The specific advantages of Lumiglas LED technology:**
 - vibration-resistant
 - long service life and operational reliability
 - LED functions up to around 50,000 hours in continuous operations
 - optimal for fittings that are difficult to access
 - no heat radiation in the light aperture (cold light)
 - no unwanted additional heat in chemical and/or biological processes
 - extremely high-contrast illumination
- **Compact design, powerful light output:** Glare-free illumination; suitable for circular sight glass fittings to DIN 28120/DIN 28121 or similar, for screw-type sight glass fittings in compliance with DIN 11851, and for sight glass fittings on flow indicators.
- **Application:** For illuminating visual flow indicators, pipelines, laboratory mixers, bio-reactors as well as the interior of tanks, hoppers, silos, agitators and other, normally closed, vessels and reactors in **potentially explosive environments**.
- **Protection class:** IP 65
- **Operating conditions:** Independent of vacuum/pressure in the vessel. Under no circumstances should a sight glass luminaire be used as a substitute for the cover flange or instead of the complete sight glass flange assembly, or on its own to close a vessel port.
- **Lumistar luminaires of this type are approved for use in ambient temperatures of between -20°C and +40°C.**
- **EC type examination certificate:** BVS 14 ATEX E 122 X
 II 2G Ex d(e) IIC T6 Gb
 II 2D Ex tb IIIC T80°C Db
- **Approved in accordance with EN 60079-ff**
- **Ignition protection category:** Ex d(e)
- **Explosion groups:** IIC (includes IIA and IIB)
 IIIC (includes IIIA and IIIB)
- **Operating voltage:**
 24 V AC/DC 35 W; 120-230 V AC 35 W
 Equipped with one high-power LED
- **Voltage type:** AC/DC
- **Simple electrical connection using integrated cable or Ex 'e' terminal box.**
- **Electrical connection options:**
Variant I: with works-fitted connection cable (standard length 2 m), temperature-resistant up to 110°C. Other cable lengths available on request: 5 m, 10 m, 20 m, or with different cable glands and cable types (see table on reverse).
Variant II: using an integrated terminal box, type Ex 'e'



Lumistar luminaire ASL57LED-Ex, variant I



Lumistar luminaire ASL57LED-Ex, variant II

- **Fastening options:** Luminaires for sight glasses on circular fittings and visual flow indicators are mounted on the cover flange by means of the hinged bracket. With screw-type sight glass fittings, the luminaire is attached to the slotted cover nut.
- ASL57LED-Ex fits the following nominal sizes:**
- a) Circular sight glass fitting acc. to DIN 28120: DN 100
 - b) Circular sight glass fitting acc. to DIN 28121: DN 125
 - c) Sight glasses in flow indicators: DN 50
 - d) Screw-type sight glass fittings similar to DIN 11851: the luminaire is fastened with a flange collar or direct on the slotted nut.

• **Dimensions and electrical data for Lumistar luminaire ASL57LED-Ex:**

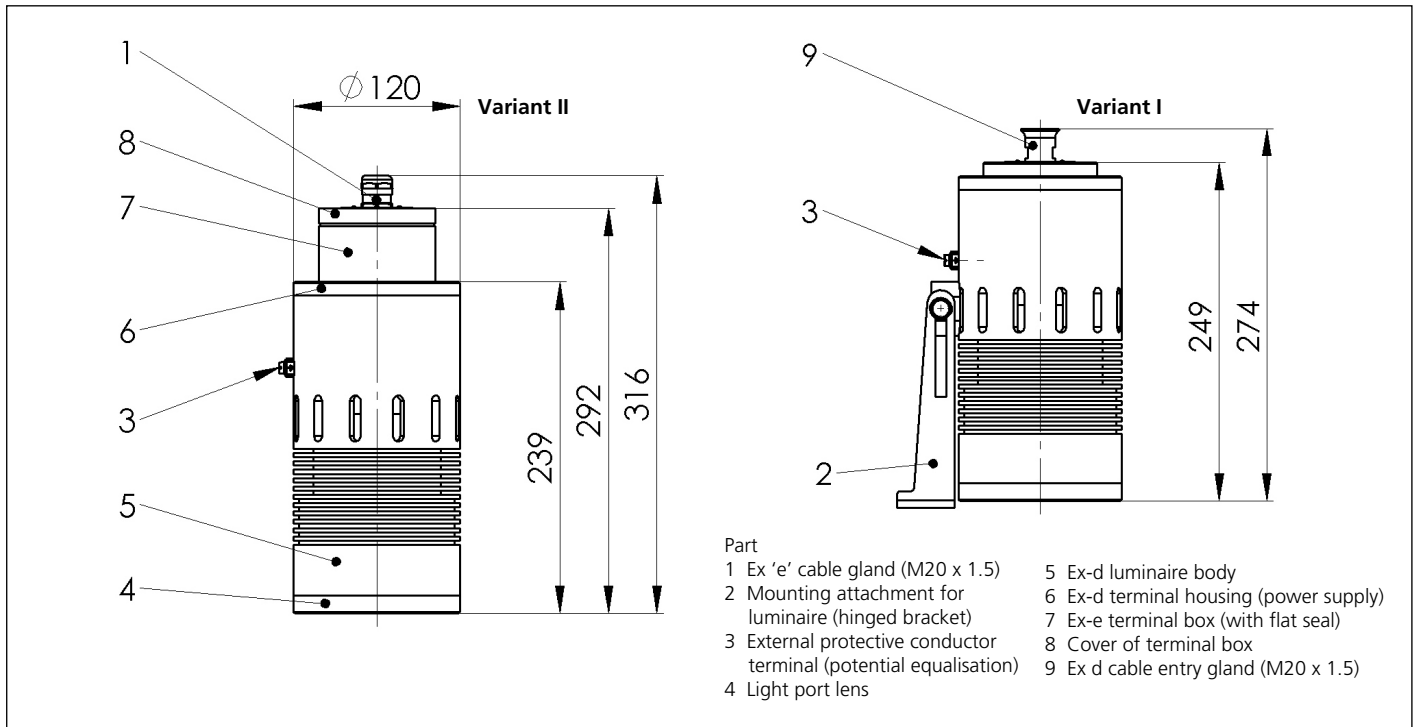

• **Components, design and materials:**

- Luminaire body (5) and cover of terminal box (8): Aluminium alloy EN AW-2007, paint finish RAL 9007
- Light port lens (4): Unit consisting of ring flange (aluminium alloy EN AW-2007, paint finish RAL 9007), and borosilicate glass

- Hinged mounting bracket (2): Stainless steel 1.4301 (see accessories)
- Cable gland (9): M20 x 1.5

• **Weight (with 2 m connecting cable):** 4.6 kg

• **Connecting data: Temperature classification and electrical parameters (see also: EC Type Examination Certificate)**

Item	ASL57LED-Ex	Part No.	Voltage V	Illuminant	Ambient temperature range $-20^{\circ}\text{C} \leq T_a \leq +40^{\circ}\text{C}$	
Variant I (with connecting cable 2 m)						
1	(24 V) 35 W	3541.484.00	24 \approx	1 high-power LED	2G T6	2D T80°C
2	(120-230 V) 35 W	3541.482.00	120-230 \sim	1 high-power LED	2G T6	2D T80°C
Variant II (with integrated terminal box)						
3	(24 V) 35 W	3541.483.00	24 \approx	1 high-power LED	2G T6	2D T80°C
4	(120-230 V) 35 W	3541.481.00	120-230 \sim	1 high-power LED	2G T6	2D T80°C

• **For variant I: only combinations of the following cable entry glands and cables should be used:**

Cable gland types	Cable types
HSK-M-Ex-d, part no. 9103.123.00 M20x1.5, nickel-plated brass (by Hummel)	EVA flexible sheathed cable, Sinotherm 110, p. no. 3403.017.00, 3x1.5 mm ² , ϕ 8.5 mm
KU1BPM20-Ex-d-Alpha X part no. 9103.130.00 M20x1.5, nickel-plated brass (by RST)	Ölflex Heat 180, part no. 3403.045.00, 3x1.5 mm ² , ϕ 8.9 mm
	Ölflex Heat 180, Silflex UR-AWG18, part no. 3403.044.00, 5x1.0 mm ² , ϕ 10.3 mm
	Ölflex Classic 110 black, part no. 3403.051.00, 3x1.5 mm ² , ϕ 10.1 mm

• **Accessories:**

Item	Component	Part No.
1	Luminaire mounting – hinged bracket	0354.029.00
2	Luminaire mounting – flanged adapter collar for welding on	MV65 = 1356.063.00; MV80 = 1356.062.00; MV100 = 1356.023.00
3	Luminaire mounting – flanged adapter for putting under	MV125 = 1356.021.00; MV150 = 1356.059.00

• **Order data:** e.g. Lumiglas luminaire ASL57LED-Ex (24 V) 35 W, Ex d IIC T6 with 2 m connecting cable, part no. 3541.484.00

All dimensions in mm unless stated otherwise. Subject to change without prior notice. 02.16