

Lumistar Luminaire USL 08-Ex, UL-listed UL + cUL T3B, T4A

- For mounting on sight glass fittings**
 Designed for use in combined sight and light glass arrangements (single-flange version) or with two separate ports (2-flange version), this sight glass luminaire is available in an Ex version with an integrated terminal compartment suitable for three terminating options.
- Compact design; powerful light output:**
 Glare-free illumination, suitable for
 - circular sight glass fittings to DIN 28120/DIN 28121 or similar, from size DN 50 up
 - screw-type sight glass fittings in compliance with DIN 11851, from size DN 100 up
 - in visual flow indicators with nominal widths from DN 50 up.
- Generous light emission thanks to optimal screwed lens design**
- Application:**
 For illuminating the interior of tanks, hoppers, silos, agitators and other, usually closed, vessels and reactors as well as visual flow indicators in **potentially explosive environments** with UL requirements.
- Suitable for use in food processing industries**
- Protection:**
 dust-proof and splash-proof, IP 65 acc. to EN 60 529/ DIN VDE 0470, Part 1
- Ignition protection, explosion group:**
 - UL 844 listed for Class I Div. 1 and 2, Groups C and D
 - UL 1571 for "wet conditions"
- Operating conditions:**
 Independent of the internal pressure/vacuum in vessel.
 On no account should a sight glass luminaire be used on its own to close a vessel port or as a replacement for the cover flange or for the complete sight glass flange assembly.
- Lumistar luminaires of this series are approved for use in ambient temperatures of up to 40°C.**
- Test certificate:** UL + cUL listed Cat No. for USL 08-Ex: 9N77
- Electrical data and equipment:** see UL specifications and table on Page 4
- Voltage type:** Alternating current (AC)
- Operating voltage:**

| | | |
|----------|--------------|-----------|
| 120 V... | Halogen lamp | 35 W/T4A |
| 120 V... | Halogen lamp | 50 W/T3B |
| 120 V... | Halogen lamp | 100 W/T3B |



Lumistar luminaire USL 08-Ex with mounting parts



Application as combined sight and light glass on a sight-glass fitting acc. to DIN 28120

• **Light bulb socket:**

Screw socket E26 or BA15d bayonett, depending on fixture (see Table on Page 4)

• **Very easy to install using special bracket (to be ordered separately) for convenience of use:**

The luminaire is normally attached to the cover flange of the round sight glass fitting or the visual flow indicator using the mounting parts, or fastened to the slotted nut on screw-type sight glass fittings.

a) **Straight bracket** for DN 50 – DN 100 (for light glasses only)

b) **Hinged bracket** from DN 125 – DN 200 (for combined sight and light glasses)

• **Straightforward electrical termination by way of terminal box**

- The luminaire is already internally wired and ready for use!
- The terminal compartment has three openings with 1/2" NPT threading (right, left, top) allowing for cable entry
- The unused openings are closed with two blanking plugs (included in scope of supply)
- No cable gland is provided with the luminaire since termination is usually effected by way of cable ducting

• **Optimised screw-in lens opens to provide ideal conditions for changing light bulbs**



Lumistar luminaire USL 08-Ex

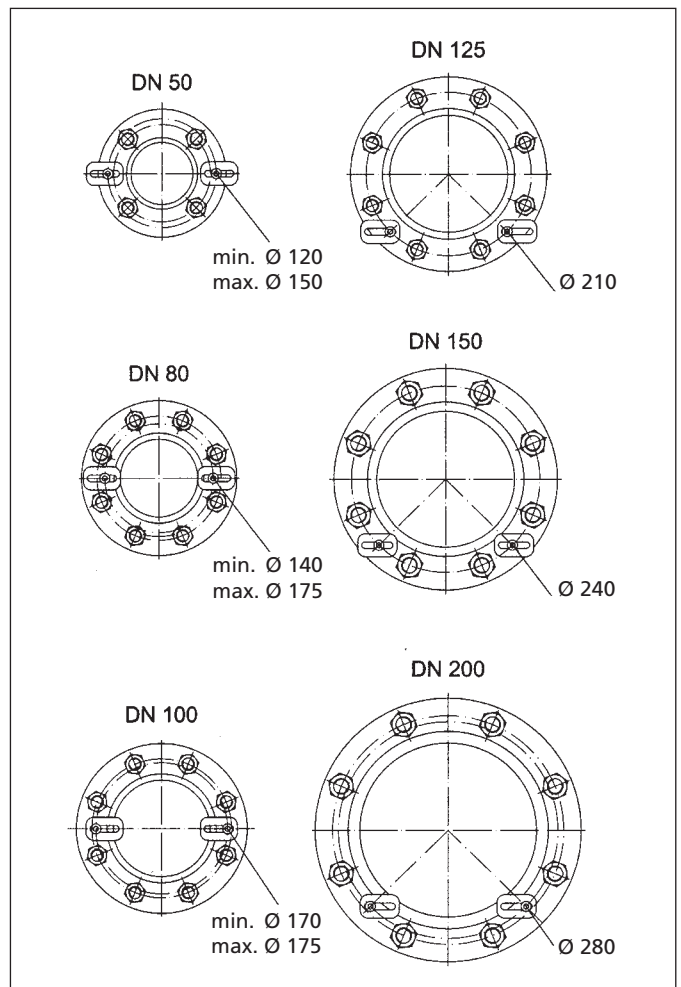

Hole pattern diameters for fastening screws

• Dimensions and electrical data for Lumistar luminaire USL 08-Ex:

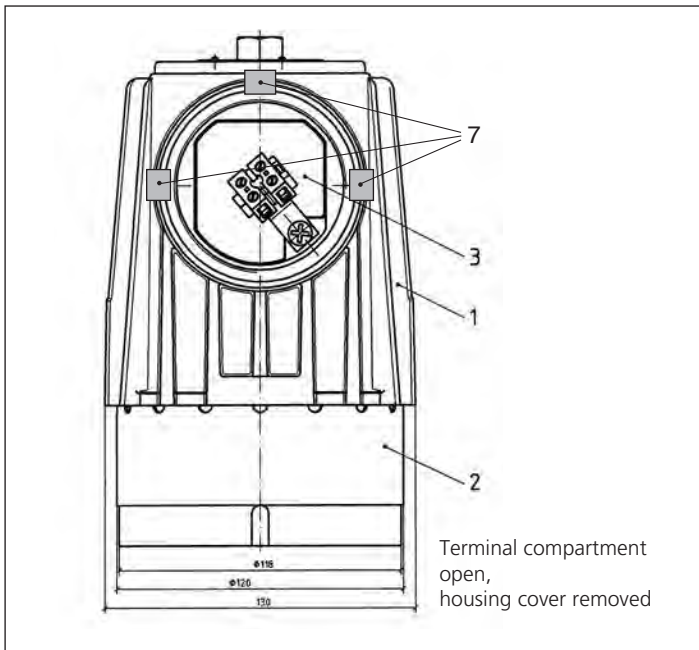

Pos. Part

- 1 Body of luminaire
- 2 Screw-type lens
- 3 Terminal compartment with terminals
- 4a Housing cover for replacing light bulb
- 4b Housing cover for terminal compartment
- 5 Screw with self-locking nut for light bulb socket
- 6 Mounting bracket for light bulb socket
- 7 3 openings with NPT 1/2" thread for cable entry options

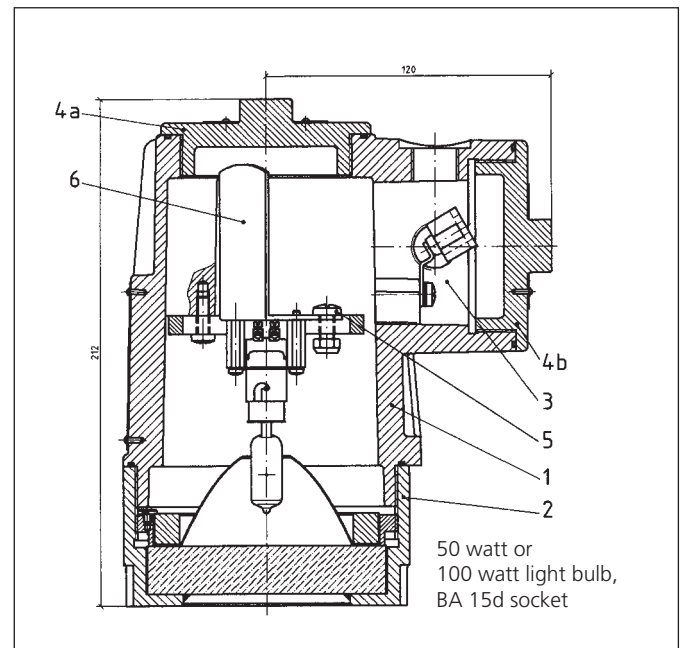
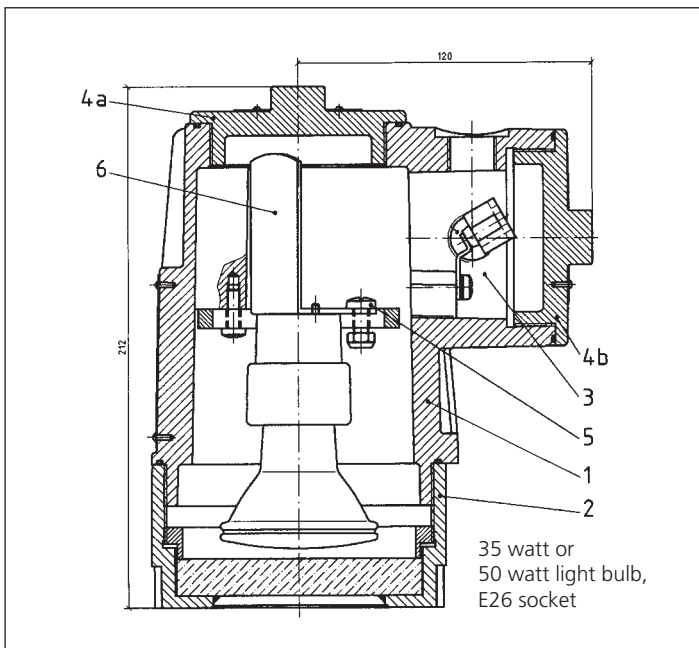

• Terminal compartment open, housing cover removed

- Body of luminaire made of non-corrosive cast aluminium alloy, GK-ALSi10Mg
- Light aperture as unit made of aluminium ring and glass with O-ring seal
- Fastening parts: (see Accessories) G-ALSi10Mg
- Weight: 3.2 kg

• **Connecting data and temperature classification:**

| Item | Type USL 08-Ex ¹⁾ | Part No. | Nom. Volt. AC | Halogen light bulb | | | | Temp. classification at max. ambient temp. 40°C |
|------|------------------------------|-------------|------------------|--------------------|--------|--------------|-------------|---|
| | | | | | Socket | Voltage | Part No. | |
| 1 | (120 V) Sp 35 W | 3540.305.00 | 120 ~ | reflector lamp | E 26 | 120 V / 35 W | 3232.248.00 | T4A |
| 2 | (120 V) Fl 35 W | 3540.305.00 | 120 ~ | reflector lamp | E 26 | 120 V / 35 W | 3232.251.00 | T4A |
| 3 | (120 V) Sp 50 W | 3540.306.00 | 120 ~ | reflector lamp | E 26 | 120 V / 50 W | 3232.249.00 | T3B |
| 4 | (120 V) Fl 50 W | 3540.306.00 | 120 ~ | reflector lamp | E 26 | 120 V / 50 W | 3232.252.00 | T3B |
| 5 | (120 V) Sp 50 W | 3540.310.00 | 120 ~ | separate refl. | BA 15d | 120 V / 50 W | 3232.275.00 | T3B |
| 6 | (120 V) Sp 100 W | 3540.308.00 | 120 ~ | separate refl. | BA 15d | 120 V/100 W | 3232.272.00 | T3B |

¹⁾ Sp = Spot; Fl = Flood

• **Accessories:**

| Item | Part no. |
|---|-------------|
| Luminaire mounting bracket, straight: for DN 50 to DN 100 | 0354.005.00 |
| Luminaire mounting bracket, angled: for DN 125 to DN 200 | 0354.006.00 |
| Special assembly spanner for screw-in lens | 6805.002.00 |

• **Order data:** e. g.

- Lumistar luminaire USL 08-Ex, 120 V/Sp 100 W, BA 15d
part no. 3540.308.00
- Mounting bracket for luminaire, straight, part no. 0354.005.00
- Special assembly spanner for screw-in lens, part no. 6805.002.00