

VISULEX Camera K15ZP-E/K15ZN-E, Stainless Steel

- **Camera with zoom lens K15ZP-E/K15ZN-E:**

The zoom lens of this camera is operated remotely from an external control room where the technical settings can be adjusted to meet the specific requirements. LumiCam system and control software provides the following functions for controlling the camera focused on the observed object using PC controls with a Windows interface:

- **Precision adjustment of**

- Zoom
- Focus
- Aperture, shutter, gain
- Documentation aids such as date and time
- Presetting functions

- **Design and applications**

- Stainless steel housing with built-in colour CCD camera, 1/4" CCD sensor, 2 lux photosensitivity; including 2-wire transmitter, electronics, stainless steel hinge as mounting bracket
- Type of protection IP 65
- Ambient temperature +5°C to +40°C

- **Zoom lens (standard version)**

- Minimum lens-to-object distance: 100 mm
- Focal length F = 4.2 to 42.0 mm
- Optical zoom 10 x
- Digital zoom 4 x extra
- Horizontal angle of view with 1/4": 4.6° to 46°

- **Electrical connection:**

- Link-up is established via control line to the control unit (camera rack with camera control module and video server, if needed) which should be ordered separately. A camera control module is required for each camera (or alternatively a video server) which is inserted into the rack. Besides single racks, racks for up to 6 camera control modules are also available.

- **Control wire:**

- 6-core cable (3 twisted pairs)
- Length: up to approx. 500 m (between camera and control unit)
- Control lead 3P x AWG 20 C

- **Weight:** 1.1 kg excluding control wire

CE

3755.429 c



VISULEX Camera K15ZP-E with zoom lens

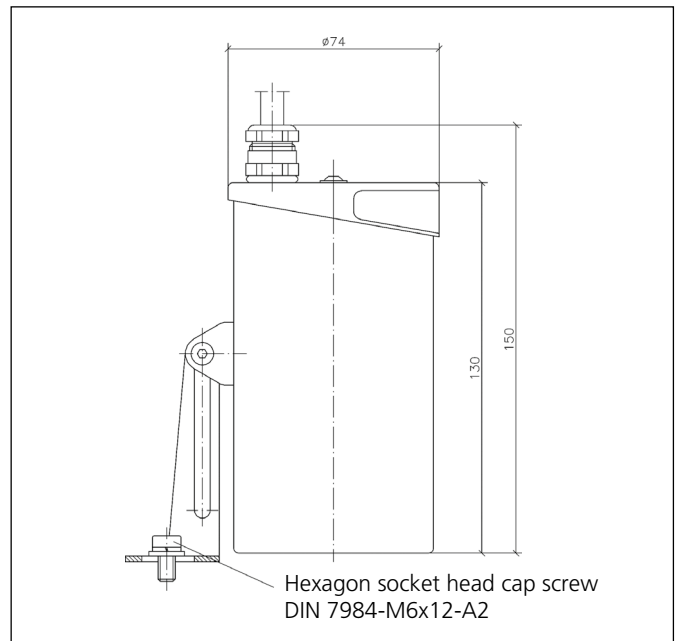

Dimensions



Single-camera rack with video server



6-camera rack equipped with three camera modules and three video servers

• **Installation:**

- The camera is mounted on the cover flange of a round sight glass fitting (DIN 28120 or similar) using the stainless steel bracket included in the scope of supply. The installation method is the same as that implemented for internationally approved Lumistar luminaires. If there is too little natural light in the vessel, an appropriately dimensioned additional Lumistar luminaire can be mounted.

- A separate arrangement of lighting glass and camera glass is a further option to be considered. This depends on the engineering process and the size of the reactor as well as on the surface of the vessel, the medium in question, and the angle of incidence.
 - Consistently uniform illumination is essential.

• **Dimensions and technical data for VISULEX Camera K15ZP-E/K15ZN-E:**

Camera	K15ZP-E (PAL)	K15ZN-E (NTSC)
Camera standard	CCIR (Europa)	EIA (USA)
Image sensor	1/4"-CCD	1/4"-CCD
Pixels	ca. 440,000	ca. 380,000
Light sensitivity	2 lux	2 lux
Resolution	460 lines (horizontal)	470 lines (horizontal)
Electronic shutter speeds	automatic, 1/1-1/10.000	automatic, 1/1-1/10.000
S/N ratio	>50 dB	>50 dB
Aperture control	automatic oder manual	automatic oder manual
Colour system	PAL	NTSC

Control unit (rack and module)	single-camera rack	6-camera rack
Power input	max. 15 W	Base load 5 W; the consumption increases by 15 W per module (max. 95 W)
Fuse protection (due to starting current)	1.6 A	6.3 A
Dimensions mm (H x W x D)	160 x 180 x 300	160 x 470 x 300

• **Order data:**

Item	Part	Part No.
1	Single-camera rack	1590.053.00
2	6-camera rack	1590.051.00
3	Camera control module	1123.008.00
4	Network unit	1128.001.00
5	Network unit with video server	1128.002.00
6	Control wire	3465.000027

For example:

VISULEX Camera K15ZP-E

- 370 m control wire (please state wire length in full metres)
- single-rack or 6-camera rack, see table
- camera control module, part-no. 1123.008.00

If supplementary cameras are to be added at a later date, we recommend the 6-module rack.