

~~COMING SOON~~

IT'S HERE

FAST 6₃₀

Range 153 - 937 mm (6" - 36")

The new **FAST 6_36** is the latest radical innovation from GBC. It has a revolutionary self-centring system. Set up time is reduced and production time increased. The **FAST 6_36** pipe cutting and bevelling machine utilises the same split frame design as the popular MCA range for ease of positioning.

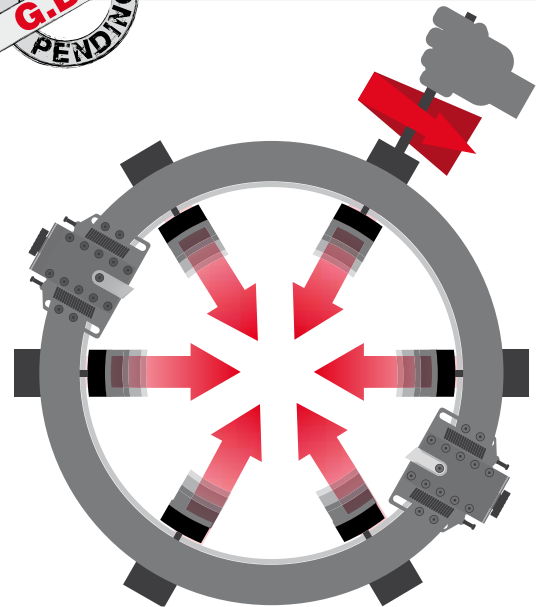

*The **FAST 6_36**, is available in three different motorizations (electric, pneumatic and hydraulic), and in its standard equipment also lists two copier tool holders for the compensation of eventual irregularities caused by ovalization of the pipe.*



Copier toolbox



High resistance clamping pad

FAST 6³⁶

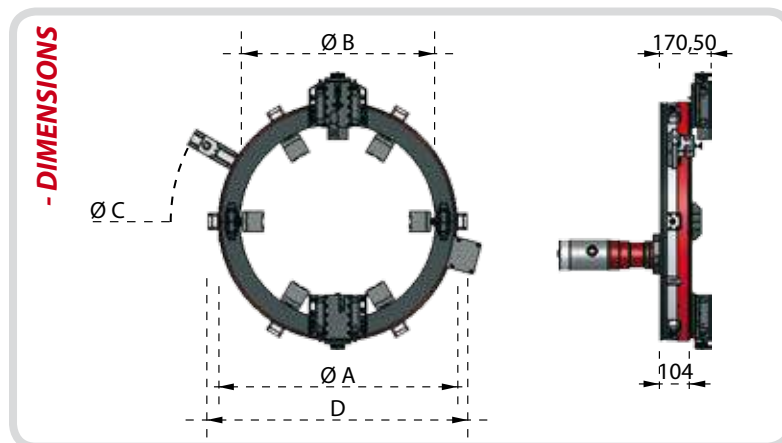

RANGE	DIMENSIONS (mm)			
	Ø A	Ø B	Ø C	D
06" - 12"	515	370	860	580
12" - 18"	665	520	1010	730
18" - 24"	815	670	1160	880
24" - 30"	965	820	1310	1030
30" - 36"	1115	970	1460	1180

TECHNICAL FEATURES

		Pneu.	Elec.	Hyd.
<i>Motor Power</i>	hp	3		15
	W	2200		11025
<i>Air Consumption</i>	L/min	3000		
	cfm	100/110		
<i>Working Pressure</i>	Bar	6		100
	psi	90		1500
<i>Electric Motor Power</i>	HP		1,33	
	W		1020	
<i>Power Supply (Frequency)</i>	V (Hz)		230 (50/60)	
<i>Working Power</i>	HP			8
	W			5880
<i>Oil Flow</i>	Lt/min			40
<i>Tool Holders Stroke</i>	mm		60	
	inch		2,36	
<i>Tool Radial Feeding</i>	mm		0,075	
	inch		0,003	
<i>Machine Idle Speed</i>	rpm		23	
<i>Weight</i>	Kg		90 ÷ 145	
	lbs			
<i>Acoustic Emissions</i>	dB		75 ÷ 78	