

# GBC HANDYBEVEL

**Portable Hand Held Plate bevelling machine  
for straight and shaped plate**



Compact, lightweight and portable, our manual plate beveler is conceived for beveling plates of reduced size and thickness, equipped with a face mill with interchangeable inserts, recommended especially for curved plates or plate with exotic profiles.

The **GBC HANDYBEVEL** is capable of executing bevels with the most common angles for which we can supply the respective face mill, it can bevel any material thanks to the different inserts available and can be employed for high productivity jobs delivering a maximum diagonal bevel length of 17mm.



## Technical Features

Power supply	230V /110v 50-60 Hz
Motor	2100W
Motor speed	6500 rpm
Minimal dia of counter - sinking	40 mm
Maximal bevel width	@ 45° (b) 17 mm
Feed	0,5 – 10 m/min (Manual)
Bevelling angles	22.5, 30, 37.5, 45, 55 and 60 degrees
Plate thickness	minimum 2.0 mm
Dimensions	585 x 156 x 238 mm
Weight	8.8 kg

Upon request GBC can supply a special face mill with inserts for rounding the sharp corners of the plate edge ( R3, R4, R5).

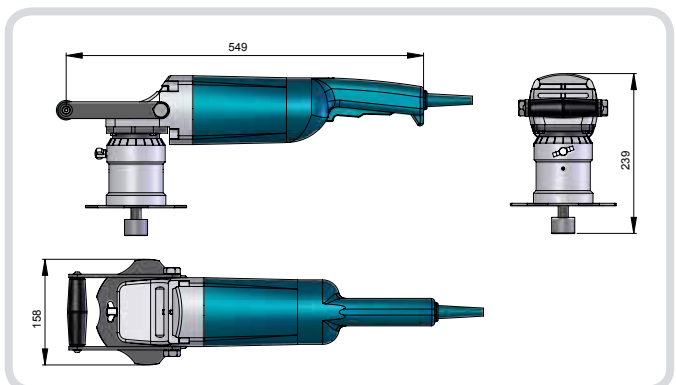

**22,5°**

**30°**

**37,5°**

**45°**

**55°**

**60°**

