

HYCUBE 24

Range 304,8 - 609,6 mm (12" - 24")

Ideal for considerably high productivity cutting and bevelling operations on series of pipe segments. Very stable steel chassis designed for quick and precise setup operations. Equipped with on board hydraulic power pack to reduce the encumbrance and to have an all-in-one piece of equipment enabling the semi-automatic lock/release operations of the pipe.

The rotation speed is adjustable through an on board speed-change drive. Conceived both for a standard positioning of the pipe as well as the positioning on pipe holders on rails.



- Stationary pipe beveller for pipe diameters from 12" to 24";
- On board hydraulic Power Pack;
- Semi-automatic Lock/Release function through an on board hydraulic power pack;
- Adjustable speed rotation achieved by an on board speed-change drive;
- Stable Steel Chassis designed for a quick and precise setup;
- Pipe positioning with pipe stand on rails.



HYCUBE 24

Range 304,8 - 609,6 mm (12" - 24")

- DIMENSIONS

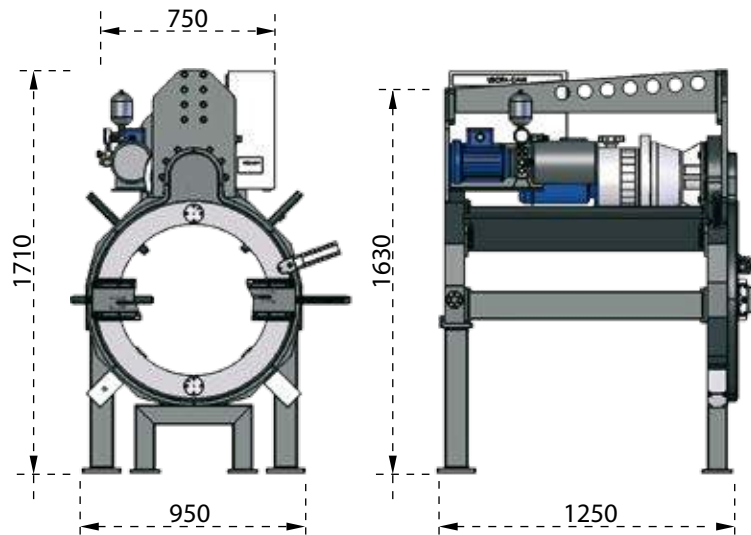

- TECHNICAL FEATURES

<i>External \varnothing locking range</i>	mm in	304.8 - 609.6 12-24
<i>Idle Speed (Min)</i>	rpm	7
<i>Idle Speed (Max)</i>	rpm	37
<i>Cutting Speed (Min)</i>	mm/min	13.24
<i>Cutting Speed (Max)</i>	mm/min	32
<i>Axial Stroke</i>	mm in	50 1.95
<i>Electric Motor Power</i>	W hp	5500 7.48
<i>Tension</i>	V	400
<i>Frequency</i>	Hz	50/60
<i>Weight</i>	kg	1030

**Different voltage available on request*