

HYPERCUTTER

Pipe cold cutting and bevelling machines

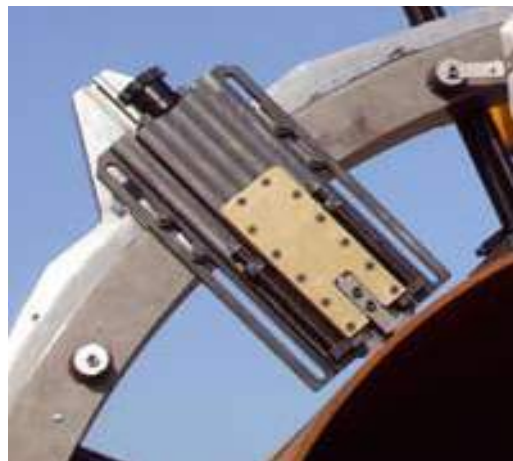

A hydraulic cold cutting and bevelling machine for the heaviest of applications, suitable for factory or on-site work.



The unit is also equipped with two copier toolboxes with the spring loaded pipe OD tracking system, minimizing the bevel offset on out of round pipe.

RANGE:

60" - 96"o/b.

FUNCTIONS:

PIPE COLD CUTTING , BEVELLING ,
FACING , COUNTERBORING.

MATERIALS:

CARBON STEEL , ALLOY , STAINLESS
STEEL , DUPLEX..

POWER:

HYDRAULIC

NOTE:

THE HYPERCUTTER RANGE
OF PORTABLE PIPE CUTTING &
BEVELLING MACHINES ARE DESIGNED
TO MEET ON SITE HEAVY DUTY
REQUIREMENTS ON LARGE PIPELINE
DIAMETERS.
SPLIT FRAME BODY AND COPIER
TOOLBOXES ARE STANDARD
FEATURES.

Extremely rugged in design, the Hypercutter is equipped with 8 heavy duty locking feet for rapid set up on all pipe diameters within its range.



The Hypercutter is a split frame design for ease of set up and operation along pipelines.

HYPERCUTTER

TECHNICAL FEATURES

Nominal hydraulic motor power	hp(kw)	40,2(30)
Hydraulic motor working power	hp(kw)	33,5(25)
Oil flow rate	gpm	15,84
Oil pressure	psi	1740
Oil hose connection	inches	3/4
Radial feed rate per revolution	inches	0,008
Tool box stroke	inches	2,75
Max noise level	dB	75

O/D RANGE	SUPPLY	gg/min rpm	WEIGHT	A	B	C
60" - 72"	Hydraulic	7	1550	2830	2465	513
72" - 84"	Hydraulic	7	1750	3000	2771	513
84" - 96"	Hydraulic	7	1930	3300	3075	513

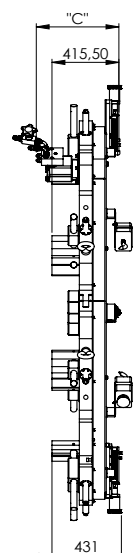
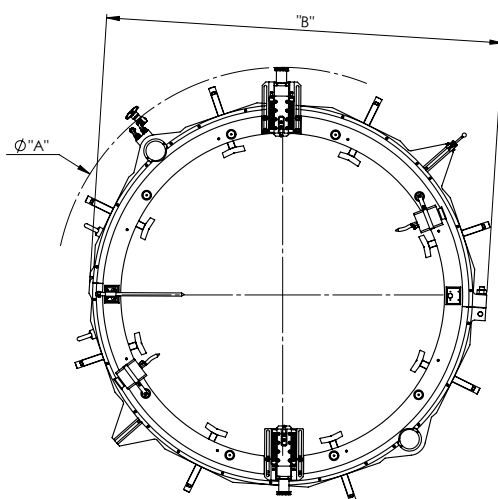

OPTIONAL



COLLECTING TRAY

TANK FOR COLLECTING SWARF ON DUTY, EQUIPPED WITH FORCED COOLANT CIRCULATION.

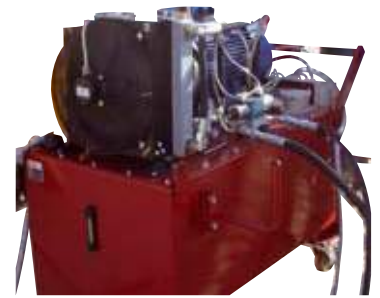

HYDRAULIC POWER PACK OIL TANK 250 L, WITH REMOTE CONTROL AND INTER-COOLER FOR EXTREMELY HEAVY DUTY WORKING SESSION & ENVIRONMENTAL

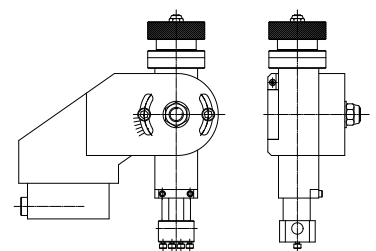

TOOLBOX FOR INSIDE BEVEL AND ID BORING UP TO 100MM DEPTH

MODELS FROM 60" UP TO 96"