

Multi EDGE

Range 6 - 60 mm (2/8" - 2 3/8")

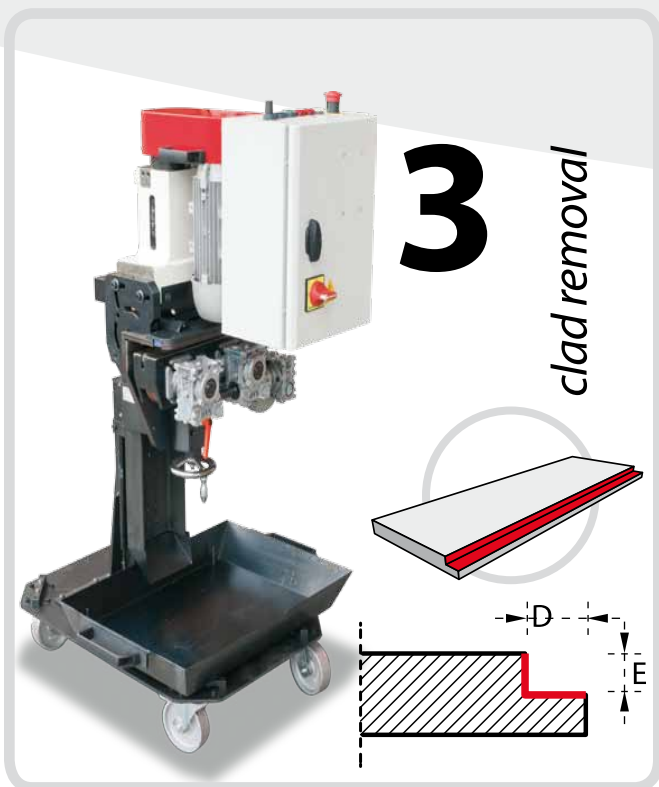
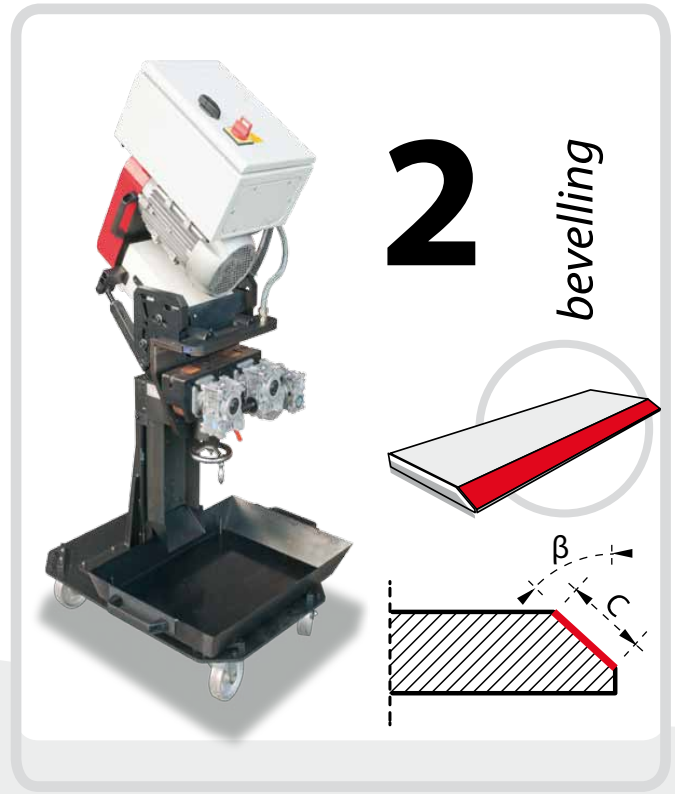
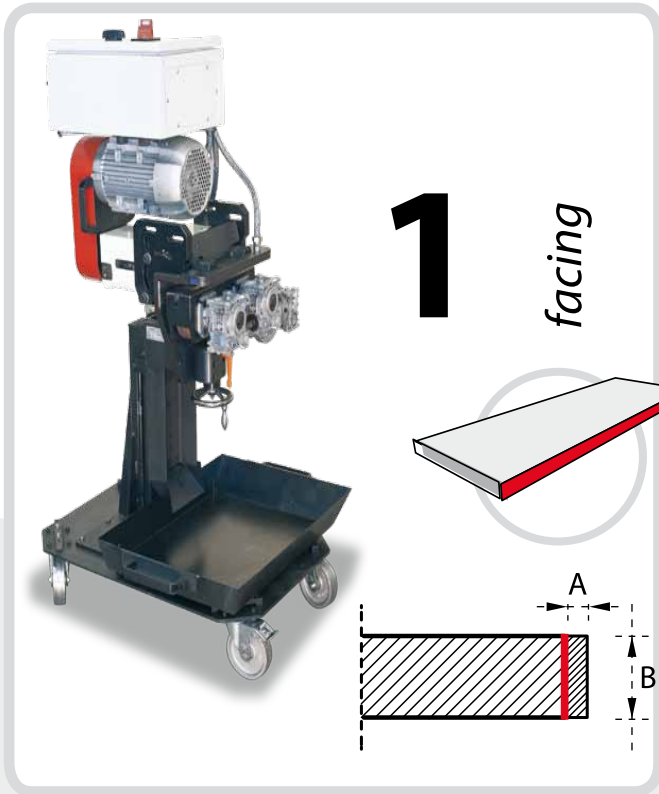

1	FACING
A	B
1 mm	Max 45 mm
2	BEVELLING
β	C
Min 15° Max 80°	40 mm
3	CLAD REMOVAL
D	E
Min 10mm Max 50mm	Max 10 mm

Compact and versatile machine with a wide functions range such as cladding removal, facing and bevelling of plates.

- TECHNICAL FEATURES

Electric motor power	w	3000
Tension	V	230 / 480
Frequency	Hz	50 / 60
Milling Head RPM	gg/min	800
Milling Head for bevel (Ø)	mm / n° inserts	80 - 9
Milling Head for Clad Removal	mm / n° inserts	80 - 8
Bevelling Angle		15° ÷ 80°
Clad removal width	mm	Min. 10 - Max 50
Max facing thickness	mm	Max 45
Plate Thickness	mm	Min. 6 - Max 60
Bevel Length (Diagonal)	mm	Min. 0 - Max 40
Feeding speed rate	mt/min	0 ÷ 1.6
Weight	kg	205
Head weight without trolley	kg	138
Trolley weight	kg	67
Max Acoustic Emissions in Idle	db	76
Media Max Acoustic Emissions in Idle	db	86

- DIMENSIONS

