

The Saphir Automatic Range

The SAPHIR range are built to meet the ever demanding requirements of clients to enable the recycling of various materials.

350AT



500AT



800AT



- Fully Automatic tying systems
- Capacities from 1.5 tonnes to 20 tonnes per hour
- Shear blades fitted as standard
- Ancillary feed systems, to include pneumatic, conveyor, hand, bin-lift
- Large loading apertures for speed of loading
- High bale densities up to 1000KG
- Uniform bale sizes for maximum payload
- Design, installation and training by UK staff.

600AT



As the sole UK suppliers of the Saphir range from **SACRIA**, WHS Ltd can supply a whole range of fully automatic tying horizontal baling presses to suit each clients specific applications.

SACRIA SAPHIR HORIZONTAL BALER – DIMENSION SPECIFICATIONS

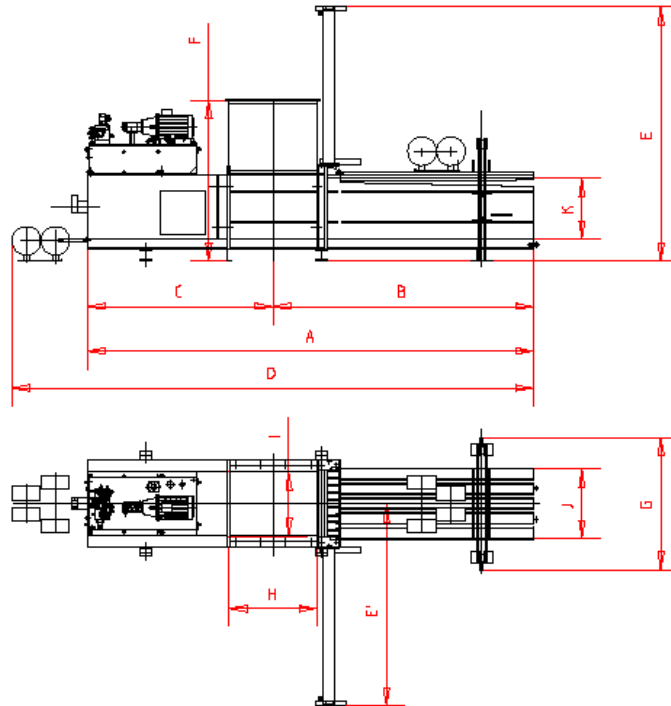

Models highlighted are available with vertical or horizontal tying systems; please see E & E'

MODEL NO	A	B	C	D	E	E'	G	H	I	J	K
SAPHIR 15	4570	2160	2410	4930	2430	-	1100	1080	640	700	500
SAPHIR 25	5800	2975	2825	5800	2850	2300	1300	1180	640	700	700
SAPHIR 40	5800	2975	2825	5800	2850	2300	1300	1180	640	700	700
SAPHIR 300	6000	3510	2490	7050	3450	3000	1780	1200	900	900	810
SAPHIR 340	6000	3510	2490	7050	3450	3000	1780	1200	900	900	810
SAPHIR 350	6000	3510	2490	7050	3450	3000	1780	1200	900	900	810
SAPHIR 450	5570	3450	2600	6620	3450	-	1780	1400	1000	1000	800
SAPHIR 500	7000	4510	2490	8050	3450	-	1780	1200	900	900	810
SAPHIR 600	6640	3620	3020	7690	3450	3000	1850	1400	1000	1000	810
SAPHIR 800	7480	4235	3245	8530	3450	3000	1780	1200	1000	1000	810

"MAKING SENSE OUT OF RUBBISH"

- 12 Month on site warranty with UK engineers
- Consumables available from stock
- Design facilities to include MRF installations
- Rental & Lease options available