

FALCO LEVEL PREMIUM+



FALCO LEVEL PREMIUM+

Go Dutch with the FalcoLevel Premium+ a gear change in usability and design. The FalcoLevel Premium+ is an innovative and user friendly cycle parking system which accommodates twice the number of bicycles compared to any other traditional cycle rack or stand.

The FalcoLevel Premium+ two-tier rack meets the Dutch national 'FietsParKeur' standard for secure cycle parking.

MODULAR DESIGN | Connect multiple units side by side for as long as required

TWO-TIER STORAGE SYSTEM | Accommodates twice as many cycles compared to any other traditional rack or stand

ALUMINIUM DESIGN | Creates a smoother and quieter user experience

FIETSPARKEUR | Meets the FietsParKeur Standard for Secure Cycle Parking

FALCOLEVEL PREMIUM+

Go Dutch with the FalcoLevel Premium+ a gear change in usability and design. The FalcoLevel Premium+ is an innovative and user friendly cycle parking system which accommodates twice the number of bicycles compared to any other traditional cycle rack or stand.

Manufactured from robust steel and aluminium, it creates a significant reduction in noise pollution, is smoother to operate and is just as easy to park a bike on the upper rack as the lower rack.

Features

Some key features of the FalcoLevel Premium+ arise from it's development cycle:

- The FalcoPremium+ has excellent build quality, typical of a Falco product.
- Utilises gas struts.
- Adjustable feet for uneven surfaces.
- Each space can be provided with a number, symbol or character upon request.
- A catch prevents the rack from sliding backwards.



Benefits

Compared to traditional two tier cycle parking systems, the new aluminium FalcoLevel Premium+ two tier cycle rack from Falco, has some distinct benefits over its cheaper rivals:

- Significant sound reduction from upper tier removing a large amount of noise pollution.
- Smoother action for the storage and retrieval of bikes.
- Just as easy to park a bicycle on the upper rack as the lower rack.
- Better suited for modern bikes with higher and wider handle bars.
- Connect multiple units side by side for as long as required.
- Available as a single or double sided version.
- Suitable for cycle tyres with a thickness of 27-50mm.
- Lighter to use than steel units making upper tier available to more cyclists.
- Ergonomic handgrip, with a thicker, warm to touch material that can be lifted with one or two hands.



- Lower lifting height (of the bike into the gutter).
- The roll in angle of the bike is less steep.
- Integrated floating feet for mounting on uneven surfaces.
- Modular design enables flexible c.t.c. bike spacing measurements.
- Stylish looking modern European design.
- Has multiple locking points for differing cycle designs.
- Robust welded construction for steel framework - hot dip galvanised to BS EN ISO 1461 and available in 192 RAL colours)



Locking points

There are two locking systems to secure a bike to the FalcoLevel-Premium+ two-tier cycle rack:

- **Upper Rack Locking Point:** The upper rack locking point is supplied as standard and can be supplied without upon request.



- **Lower Rack Locking Point:** To provide additional security for cycles parked on the lower racks with a centre to centre distance of 400mm, a secure locking mount can be supplied upon request. The secure locking mount can be provided for both new racks and existing racks.

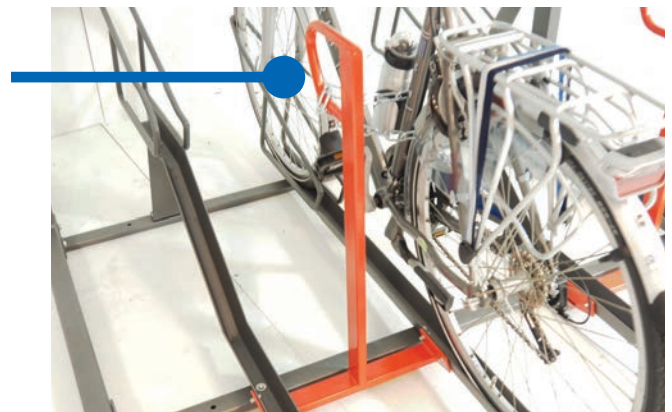

Optional

- **Upright Cover Plate:** An upright end cover plate can be supplied upon request for cycle parking areas unable to expand using standard add-on sections.
- **Cycle Space Identification:** Each cycle parking space can be allocated with a number or company logo or scheme to identify individual cycle parking spaces.



The FalcoLevel Premium+ is suitable for indoor or outdoor use. Falco also manufacture a range of single sided and double sided shelter and canopy structures ideal for sheltering the two-tier system.

FALCOLEVEL PREMIUM+ 375 MM CENTRE-TO-CENTRE

| Single Sided | Double Sided | Posts | Length mm | Single Sided | Double Sided | Posts | Length mm | Single Sided | Double Sided | Posts | Length mm |
|--------------|--------------|-------|-----------|--------------|--------------|-------|-----------|--------------|--------------|-------|-----------|
| 4 | 8 | 2 | 1035 | 34 | 68 | 4 | 6770 | 66 | 132 | 6 | 12880 |
| 6 | 12 | 2 | 1410 | 36 | 72 | 4 | 7145 | 68 | 136 | 6 | 13255 |
| 8 | 16 | 2 | 1785 | 38 | 76 | 4 | 7520 | 70 | 140 | 6 | 13630 |
| 10 | 20 | 2 | 2160 | 40 | 80 | 4 | 7895 | 72 | 144 | 6 | 14005 |
| 12 | 24 | 2 | 2535 | 42 | 84 | 4 | 8270 | 74 | 148 | 6 | 14380 |
| 14 | 28 | 2 | 2910 | 44 | 88 | 4 | 8645 | 76 | 152 | 6 | 14755 |
| 16 | 32 | 2 | 3285 | 46 | 92 | 4 | 9020 | 78 | 156 | 6 | 15130 |
| 18 | 36 | 3 | 3715 | 48 | 96 | 4 | 9395 | 80 | 160 | 6 | 15505 |
| 20 | 40 | 3 | 4090 | 50 | 100 | 5 | 9825 | 82 | 164 | 7 | 15935 |
| 22 | 44 | 3 | 4465 | 52 | 104 | 5 | 10200 | 84 | 168 | 7 | 16310 |
| 24 | 48 | 3 | 4840 | 54 | 108 | 5 | 10575 | 86 | 172 | 7 | 16685 |
| 26 | 52 | 3 | 5215 | 56 | 112 | 5 | 10950 | 88 | 176 | 7 | 17060 |
| 28 | 56 | 3 | 5590 | 58 | 116 | 5 | 11325 | 90 | 180 | 7 | 17435 |
| 30 | 60 | 3 | 5965 | 60 | 120 | 5 | 11700 | 92 | 184 | 7 | 17810 |
| 32 | 64 | 3 | 6340 | 62 | 124 | 5 | 12075 | 94 | 188 | 7 | 18185 |
| | | | | 64 | 128 | 5 | 12450 | 96 | 192 | 7 | 18560 |

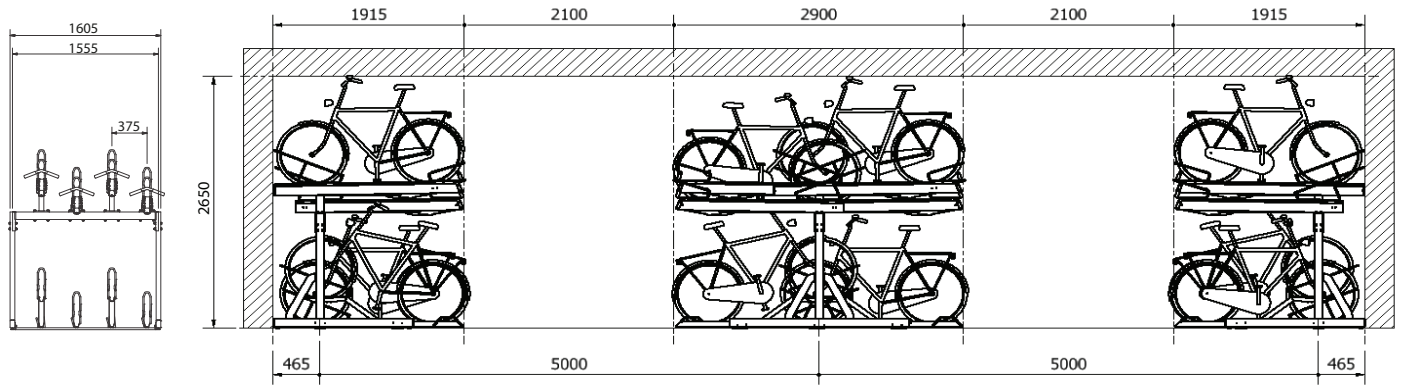

FALCOLEVEL PREMIUM+ 400 MM CENTRE-TO-CENTRE

| Single Sided | Double Sided | Posts | Length mm | Single Sided | Double Sided | Posts | Length mm | Single Sided | Double Sided | Posts | Length mm |
|--------------|--------------|-------|-----------|--------------|--------------|-------|-----------|--------------|--------------|-------|-----------|
| 4 | 8 | 2 | 1085 | 34 | 68 | 4 | 7170 | 66 | 132 | 6 | 13655 |
| 6 | 12 | 2 | 1485 | 36 | 72 | 4 | 7570 | 68 | 136 | 6 | 14055 |
| 8 | 16 | 2 | 1885 | 38 | 76 | 4 | 7970 | 70 | 140 | 6 | 14455 |
| 10 | 20 | 2 | 2285 | 40 | 80 | 4 | 8370 | 72 | 144 | 6 | 14855 |
| 12 | 24 | 2 | 2685 | 42 | 84 | 4 | 8770 | 74 | 148 | 6 | 15255 |
| 14 | 28 | 2 | 3085 | 44 | 88 | 4 | 9170 | 76 | 152 | 6 | 15655 |
| 16 | 32 | 2 | 3485 | 46 | 92 | 4 | 9570 | 78 | 156 | 6 | 16055 |
| 18 | 36 | 3 | 3927,5 | 48 | 96 | 4 | 9970 | 80 | 160 | 6 | 16455 |
| 20 | 40 | 3 | 4327,5 | 50 | 100 | 5 | 10412,5 | 82 | 164 | 7 | 16897,5 |
| 22 | 44 | 3 | 4727,5 | 52 | 104 | 5 | 10812,5 | 84 | 168 | 7 | 17297,5 |
| 24 | 48 | 3 | 5127,5 | 54 | 108 | 5 | 11212,5 | 86 | 172 | 7 | 17697,5 |
| 26 | 52 | 3 | 5527,5 | 56 | 112 | 5 | 11612,5 | 88 | 176 | 7 | 18097,5 |
| 28 | 56 | 3 | 5927,5 | 58 | 116 | 5 | 12012,5 | 90 | 180 | 7 | 18497,5 |
| 30 | 60 | 3 | 6327,5 | 60 | 120 | 5 | 12412,5 | 92 | 184 | 7 | 18897,5 |
| 32 | 64 | 3 | 6727,5 | 62 | 124 | 5 | 12812,5 | 94 | 188 | 7 | 19297,5 |
| | | | | 64 | 128 | 5 | 13212,5 | 96 | 192 | 7 | 19697,5 |

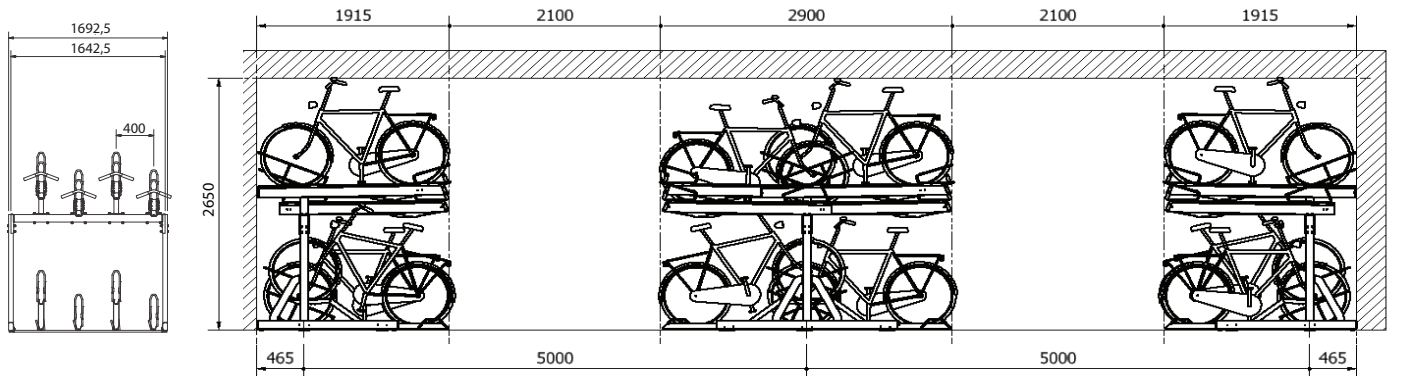



MAINTENANCE

Inspection of the FalcoLevel Premium+, to be carried out annually

- Check the operation of the complete system
- Inspect the mounting material
- Identify damage as a result of vandalism
- Inform the client
- Issue quotation for any parts to be replaced

Preventive maintenance, to be carried out periodically in consultation with the client

- Test the gas spring and the operation of the extension gutter
- Identify damage as a result of vandalism
- Inform the client
- Issue quotation for any parts to be replaced

Cleaning

- Clean upper and lower gutters (only the free bicycle spaces)
- Clean leaf and garbage residue from the lower rack (only the free bicycle spaces)
- Clean any coating
- Client must dispose of garbage which will be collected at a location to be specified by the client
- Water supply tap must be available, as well as a drain

The above activities will only and exclusively be carried out in consultation with the client. After specifying a date, the client must ensure that the workspace is freely accessible and free from obstacles.

Replacement parts will be quoted for and are not included, nor are working hours that are accumulated due to not being able to carry out the maintenance activities or cleaning.



FALCOLEVEL PREMIUM+

| Description | Part Code | | |
|--|------------|--|--|
| FalcoLevel Premium + cycle rack, single sided, 3 upper and 3 lower spaces to accommodate 6 bikes, c.t.c 375mm, length 1,180mm | 00.353.037 | | |
| FalcoLevel Premium + cycle rack, single sided, 3 upper and 3 lower spaces to accommodate 6 bikes, c.t.c 400mm, length 1,243mm | 00.353.040 | | |
| FalcoLevel Premium + cycle rack, single sided, 4 upper and 4 lower spaces to accommodate 8 bikes, c.t.c 375mm, length 1,500mm | 00.354.037 | | |
| FalcoLevel Premium + cycle rack, single sided, 4 upper and 4 lower spaces to accommodate 8 bikes, c.t.c 400mm, length 1,643mm | 00.354.040 | | |
| FalcoLevel Premium + cycle rack, single sided, 6 upper and 6 lower spaces to accommodate 12 bikes, c.t.c 375mm, length 2,305mm | 00.356.037 | | |
| FalcoLevel Premium + cycle rack, single sided, 6 upper and 6 lower spaces to accommodate 12 bikes, c.t.c 400mm, length 2,443mm | 00.356.040 | | |
| FalcoLevel Premium + cycle rack, double sided, 8 upper and 8 lower spaces to accommodate 16 bikes, c.t.c 187.5mm, length 1,555mm | 00.368.018 | | |
| FalcoLevel Premium + cycle rack, double sided, 8 upper and 8 lower spaces to accommodate 16 bikes, c.t.c 200mm, length 1,643mm | 00.368.020 | | |
| FalcoLevel Premium + cycle rack, double sided, 10 upper and 10 lower spaces to accommodate 20 bikes, c.t.c 200mm, length 2,043mm | 00.370.020 | | |
| FalcoLevel Premium + cycle rack, double sided, 12 upper and 12 lower spaces to accommodate 24 bikes, c.t.c 187.5mm, length 2,305mm | 00.372.018 | | |
| FalcoLevel Premium + cycle rack, double sided, 12 upper and 12 lower spaces to accommodate 24 bikes, c.t.c 200mm, length 2,443mm | 00.372.020 | | |
| FalcoLevel Premium + cycle rack, double sided, 14 upper and 14 lower spaces to accommodate 28 bikes, c.t.c 187.5mm, length 2,343mm | 00.374.018 | | |

FALCOLEVEL PREMIUM+, OPTIONAL

| Description | Part Code | | |
|--|---------------|--|--|
| FalcoLevel Premium+ loose provision to be bolted on for two point locking of the bike, for the upper level | 00.352.000H | | |
| FalcoLevel Premium+ loose provision to be bolted on for two point locking of the bike, for the lower level | 00.352.000L | | |
| FalcoLevel Premium+ lower rack locking point, security for cycles parked on the lower racks with a c.t.c. distance of 400mm | 00.352.040L | | |
| FalcoLevel Premium+ upright cover plate | OND00.350.310 | | |

HOW TO USE THE FALCOLEVEL PREMIUM+ TWO TIER CYCLE RACK

Parking a Bike

1. Grasp the handle and pull the upper rack fully outwards
2. Gently lower the rack to the floor
3. Place the front wheel of your bike onto the rack and wheel your bike along allowing the rear wheel to sit in the recess at the front
4. Using the handle gently raise the rack back into its upright position
5. Push the rack back until it locates over the 'stop' position

Removing a Parked Bike

1. Grasp the handle and pull the upper rack fully outwards
2. Gently lower the rack to the floor
3. Lift the rear bicycle wheel out of the rear support and roll the bicycle off the cycle rack
4. Grasp the handle and pull the rack back into its upright position
5. Push the rack back until it locates over the 'stop' position

