

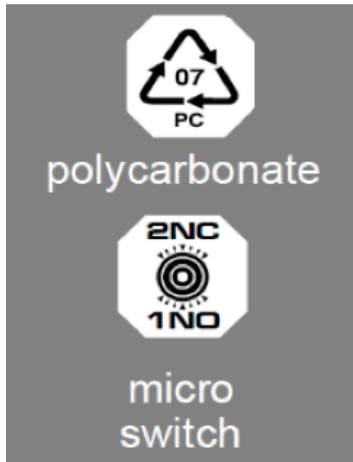

## June 2017 Machinery Guarding Update

### Drilling Machine Guards – EN12717 from Machine Covers Limited



The Repar2 drilling machine guarding range is, in our opinion, the best available as it provides the greatest level of protection, practicality and versatility.

The range is available with single or double shockproof polycarbonate screens. There is a positive-action electromechanical interlocking device – degree of protection: IP67 B10d (number of cycles): 20,000,000.

Once the guard is installed and secured, the contacts of the interlocking device need to be wired into a safety circuit by the installer in order to guarantee chuck stopping. This is a mandatory requirement (see the Machinery Directive).

Our range of Repar2 drilling machine guards offers excellent quality and innovative design incorporating the following benefits:

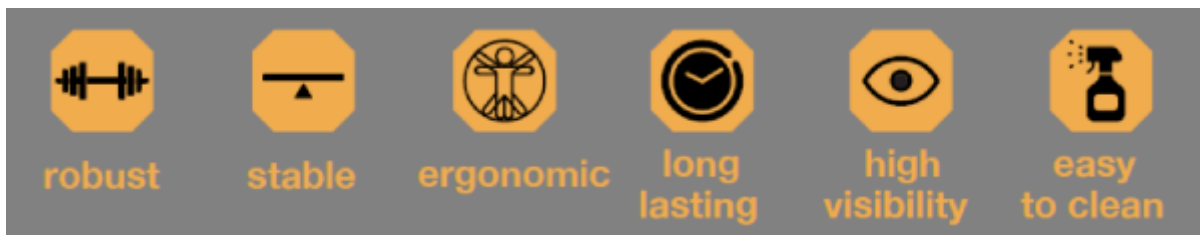

**- Types of drill guard available -**

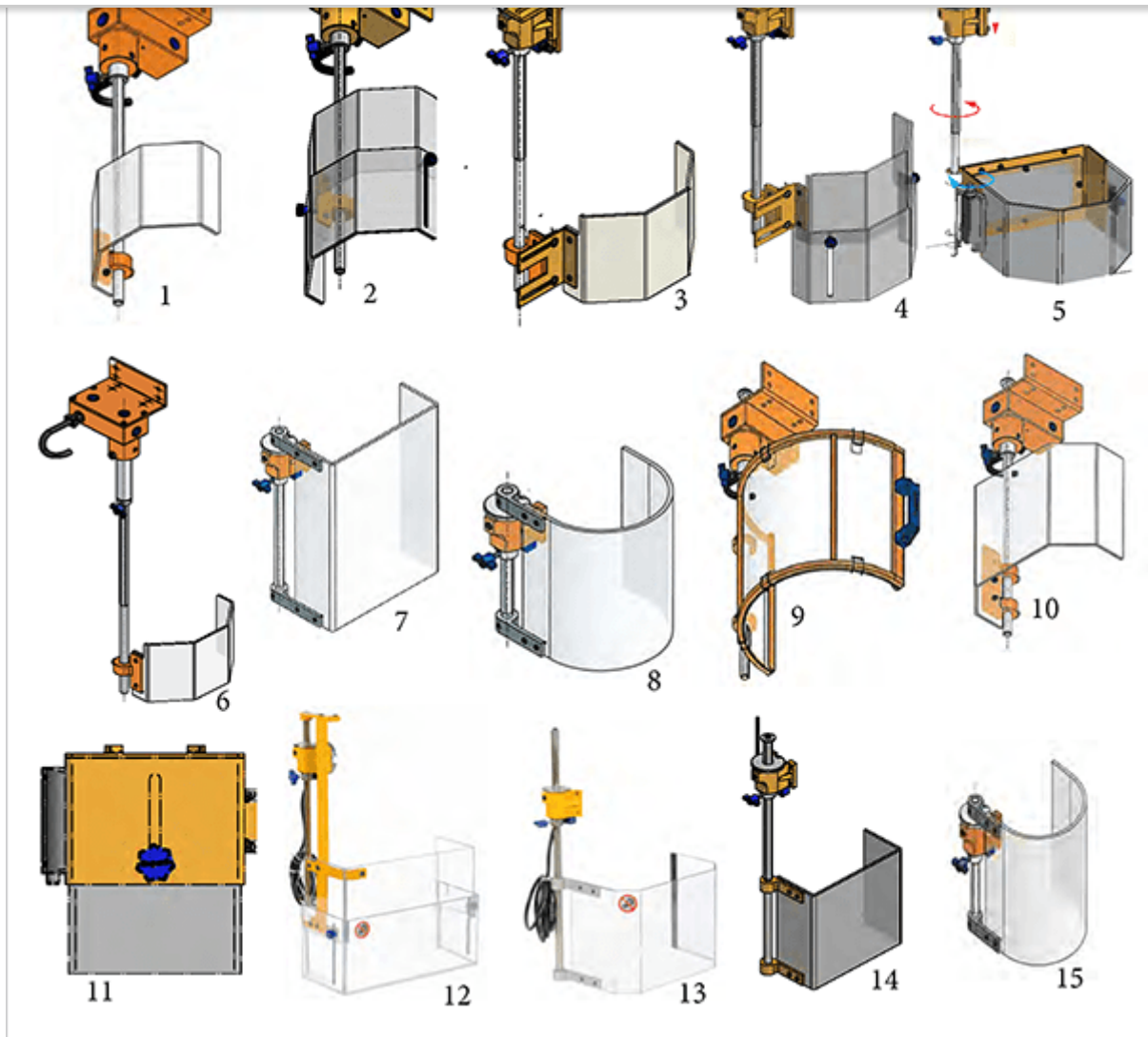

1 - TR2 (200mm wide x 130mm high)

2 - TR2DS (200mm wide x 240mm high total)

3 - TR2KSP (200mm wide x 130mm high)

4 - TR2KSPDS (200mm wide x 240mm high total)

5 - TR2T (220mm wide x 130mm high)

6 - TR7 (200mm wide x 130mm high)

7 - TR5 (230mm wide x 310mm high)

10 - TR3A (300mm wide x 200mm high)

11 - TRT (170mm x 170mm square x 260mm high total)

12 - TRE31 (350mm wide x 135mm deep x 270mm high total)

13 - \*TR F-G-H-I-J

\* F - 307mm wide x 130mm deep x 150mm high

\* G - 230mm wide x 150mm deep x 200mm high

\* H - 280mm wide x 150mm deep x 200mm high

\* I - 300mm wide x 200mm deep x 200mm high

\* J - 280mm wide x 150mm

high)

9 - TR3B (300 to 600mm  
diameter x 240mm high)

14 - TRFL (205mm wide x  
85mm deep x 200mm high)

15 - TR1 (120mm wide  
x200mm high)

### - Examples of drill guard types with various drilling machines -

1. TR2 (200mm wide x 130mm high)

This is ideal for Meddings, Hines and Clarke drills.



2. TR2DS (200mm wide x 240mm high total)

This is ideal when a more versatile screen for various drill lengths is required.

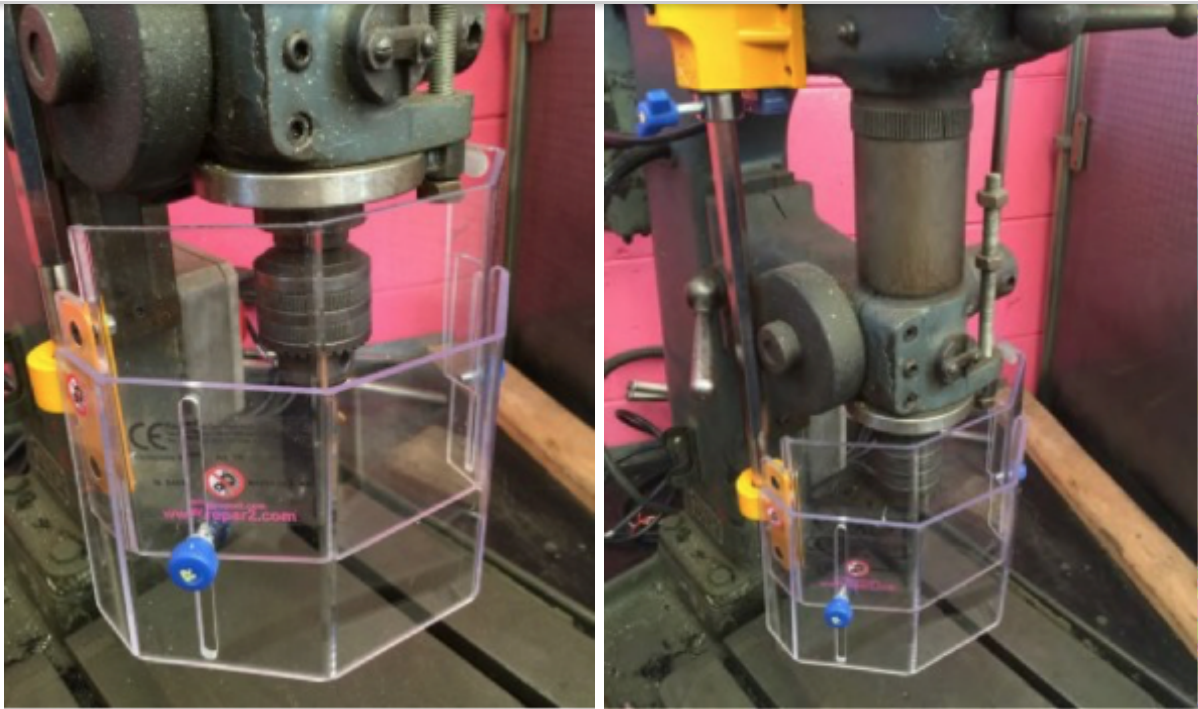

### 3. TR2KSP (200mm wide x130mm high)

This is ideal for Meddings drills, Ajax drills, XYZ drills and Progress drills.



#### 4. TR2KSPDS (200mm wide x 240mm high total)

This is ideal when a more versatile screen for various drill lengths is required, with the KSP kit allowing exact screen and switch positioning.

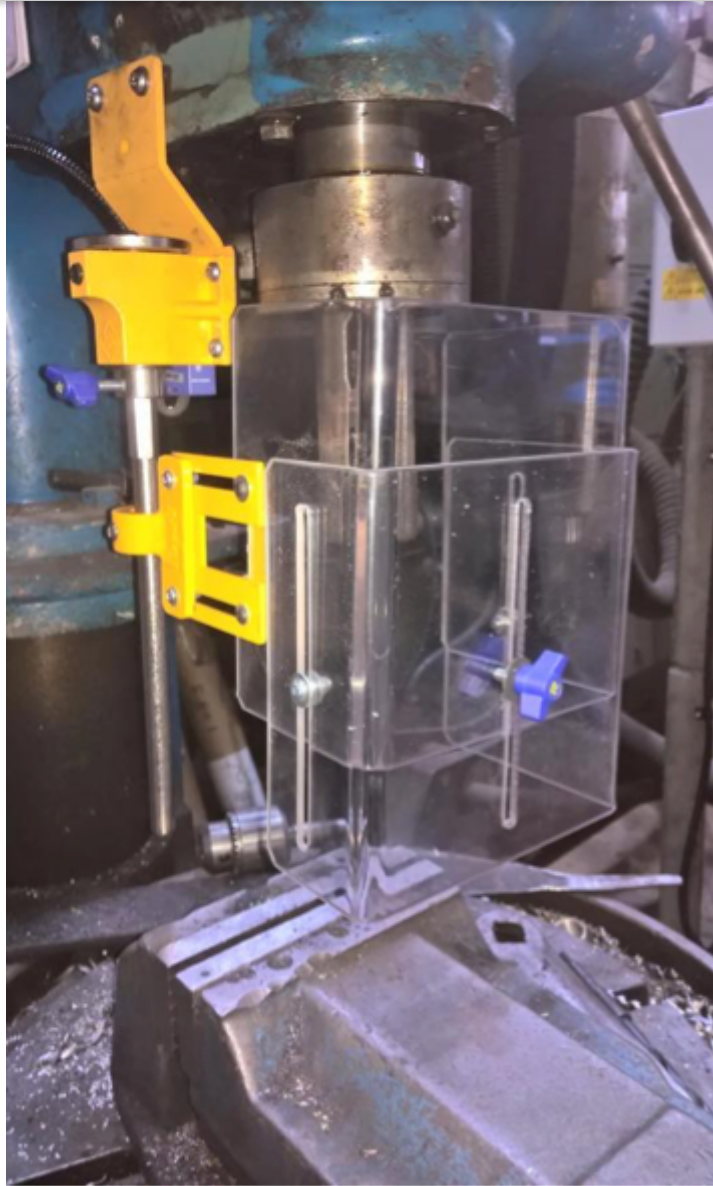

##### 5. TR2T (220mm wide x 130mm high)

This is ideal for any drilling machine where 360 degree chuck and tool coverage is required.

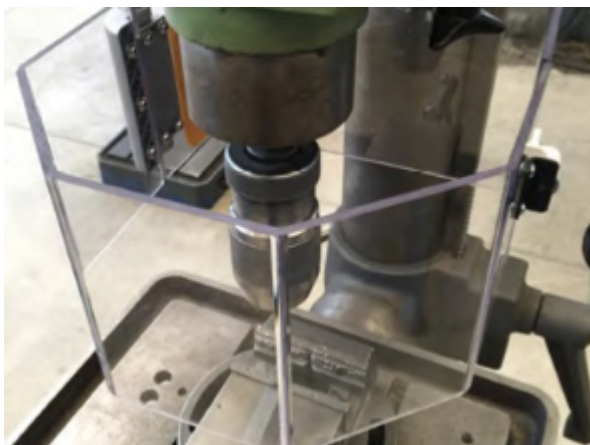

This is ideal for Clausing drills or any other model if a large screen is required (as shown below).



7. TR5 (230mm wide x 310mm high)

This is ideal for large drills and smaller milling machines.



### 8. TR6 (170mm wide x 200mm high)

This is ideal for Pollard drills and Startrite drills.

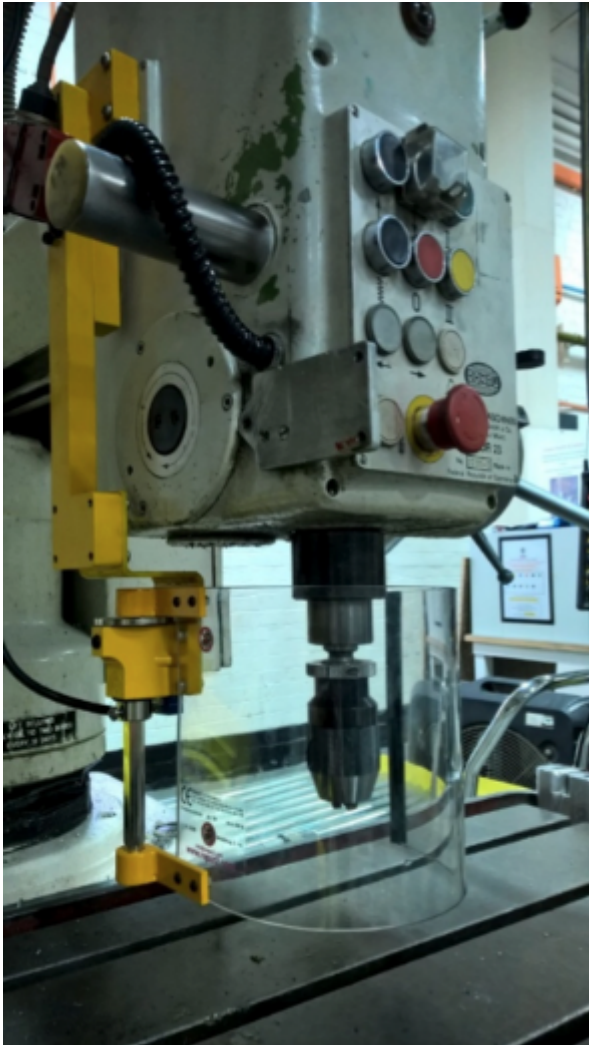

### 9. TR3B (300 to 600mm diameter x 240mm high)

This is ideal for radial drilling machines.





10. TR3A (300mm wide x 200mm high)  
This is ideal for radial drilling machines.

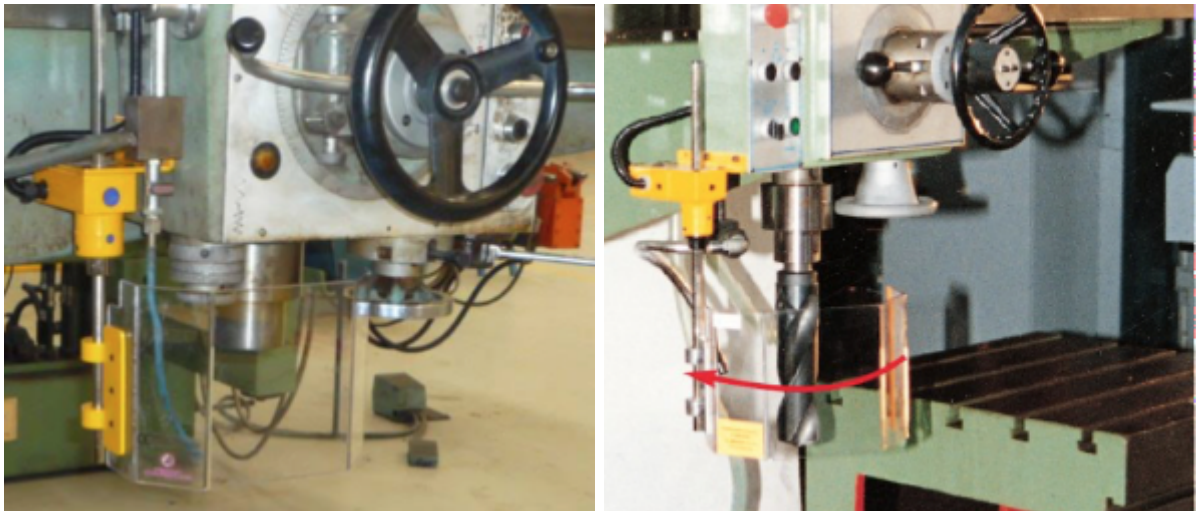

11. TRT (170mm x 170mm square x 260mm high total)  
This is ideal for Pollard drills and Bridgeport milling machines.



12. TRE31 (350mm wide x 135mm deep x 270mm high total)  
This is ideal for large drills, boring machines and milling machines.



15. TR1 (120mm wide x200mm high)  
This is deal for Ajax drills and band saws.



For more information about our range of Repar2 drilling machine guarding please email [info@machinecovers.co.uk](mailto:info@machinecovers.co.uk) or call us on 01452 770166

This email was sent to you by Machine Covers Limited.  
Contact [info@machinecovers.co.uk](mailto:info@machinecovers.co.uk) or +44 (0)1452 770166 for more information

This email was sent to <<Email Address>>  
[why did I get this?](#) [unsubscribe from this list](#) [update subscription preferences](#)  
Machine Covers · Stancombe Works · Stroud Road · Bisley, Gloucestershire GL6 7NQ · United Kingdom

---

MailChimp