



Somnium Signs Ltd



**Display, Signage, Café Barriers
& Pedestrian Guidance Systems**

contents

roller banners	3	carry equipment and accessories ..	30 - 31
atom	4	pavement signage	33
neo	4	sign wedge	34
hex	5	folding swing sign	34
zeta	5	classic	35
genie	6	switch	35
sigma	6	aquabase prime	36
sidewinder	7	aquabase swap	36
omega	8	a-frame	37
bantam	8	forecourt signage	38
static banners	9	A1 H20 swingmaster	39
cobra	10	A0 H20 swingmaster	40
illusion	10	icon	41
outdoor banners	11	icon plus	41
cyclone	12	icon max	41
polar	12	indoor signage	43
typhoon	13	snapframes	44
outdoor a banner	13	sign holders	45
vision	14	telescopic sign holders	45
pop-up systems	15	telescopic iPad holder - floor standing	46
advantage - curved	16	iPad holder - fixed height	46
advantage - straight	17	iPad holder - wall or desktop	47
supremacy	18	iPad holder - desktop	47
modular displays	19	universal tablet holder - floor standing	48
fusion rapid	20	universal tablet holder - desktop	48
fusion versa	20	universal folding tablet stand	49
fusion accessories	21	poster snappers	49
fusion footprints	22	café barriers systems	51
folding panel kits	23	primo slide	52
literature stands	24	primo wrap	53
onyx	25	medio slide	54
media compact portrait	25	medio wrap	55
media 4 deluxe	26	espresso	56
promotion unit	26	pedestrian guidance systems	58
lighting	27 - 29	queue management	59
		rope barriers	60
		market stall	61

BANNERSTANDS

POP-UP SYSTEMS

MODULAR DISPLAYS

LITERATURE STANDS AND PROMOTION UNITS

LIGHTING AND CARRY EQUIPMENT

display



rollerbanners

QUICK REFERENCE GUIDE



PRODUCT SELECTOR

	atom	neo	hex	zeta
PRICE INDICATOR	£	£ £	£ £	£ £
GRAPHIC WIDTH	800/850mm	600/800/850/1000/1200/1500mm	600/800/850/1000/1200/1500mm	800 / 850mm
HANGER TYPE	Gripping	Gripping	Gripping	Mechanical
POLE TYPE	3 part bungee	3 part bungee* <small>*600mm pole has a 4 part bungee</small>	3 part bungee* <small>*600mm pole has a 4 part bungee</small>	Telescopic
	PAGE 4	PAGE 4	PAGE 5	PAGE 5



N.B Photo not to scale

PRODUCT SELECTOR

	genie	sigma	sidewinder	omega	bantam
PRICE INDICATOR	£ £ £	£ £ £	£ £ £ £	£ £ £ £	£
GRAPHIC WIDTH	800/1000mm	800/1000mm	600/800/1000/1200/1500mm	780mm [fabric]	297mm
HANGER TYPE	Gripping	Mechanical	Self-adhesive	N/A	Self-adhesive
POLE TYPE	3 part bungee	Telescopic	4 part bungee	3 part bungee	2 part steel pole
	PAGE 6	PAGE 6	PAGE 7	PAGE 8	PAGE 8

NOTE: Hardware only no graphics included.

atom



800mm footprint: 815 [w] x 380 [d]mm
850mm footprint: 865 [w] x 380 [d]mm

CODE	DESCRIPTION
91756	Atom 800mm
91757	Atom 850mm

features

- Entry level roller banner
- 800mm and 850mm widths, single-sided
- Visible graphic height 1990mm
- Sure grip, slim profile, gripping hanger
- Strong, fixed height, 3 part bungeed pole set
- Two twist out feet
- Canvas carry bag included
- Unbranded instructions and packaging
- 1m adhesive hook fastener included

neo



600mm footprint: 615 [w] x 380 [d]mm
800mm footprint: 815 [w] x 380 [d]mm
850mm footprint: 865 [w] x 380 [d]mm
1000mm footprint: 1015 [w] x 380 [d]mm
1200mm footprint: 1215 [w] x 380 [d]mm
1500mm footprint: 1515 [w] x 380 [d]mm

CODE	DESCRIPTION
91825	Neo 600mm wide
91754	Neo 800mm wide
91755	Neo 850mm wide
91826	Neo 1000mm wide
91827	Neo 1200mm wide
91828	Neo 1500mm wide

features

- Thicker aluminium extrusions for main unit and feet
- Sure grip, slim profile, gripping hanger
- Strong, fixed height, 3 part bungeed pole set*
- Single-sided, available in 6 widths
- Two twist out feet
- Unbranded instructions and packaging
- Padded carry bag
- Individually boxed

*Pole for Neo 600mm unit is a 4 part bungeed pole set.

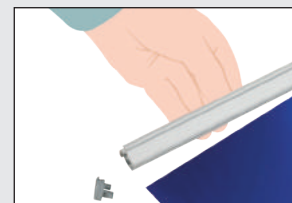

Sure grip hanger.

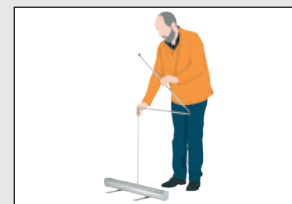

Fixed height bungeed pole set.



Two twist out feet.

GRAPHIC PANEL SIZES

- **Finished size:**
2200 x 800/850mm [inc. 200mm bleed]
- **Visual area:**
1990 x 800/850mm [top 10mm of graphic hidden by the top gripper rail]



Thicker end cap.



Padded bag.



Individually boxed.

GRAPHIC PANEL SIZES

- **Finished size:**
2200 x 600/800/850/1000/1200/1500mm [inc. 200mm bleed]
- **Visual area:**
1990 x 600/800/850/1000/1200/1500mm [top 10mm of graphic hidden by the top gripper rail]

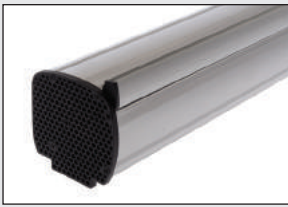

Stylish embossed black plastic end caps.



Two twist out feet.



Padded bag and individually boxed.

GRAPHIC PANEL SIZES

- **Finished size:**
2115 x 600/800/850/1000/1200/1500mm [inc. 110mm bleed]
- **Visual area:**
2005 x 600/800/850/1000/1200/1500mm [top 10mm if graphic hidden by the top gripper rail]



Adjustable telescopic pole set.

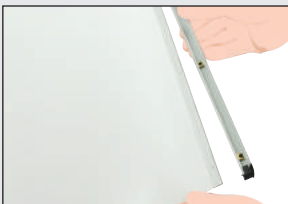

Mechanical style top hanger.



Can be used as a desktop system.

GRAPHIC PANEL SIZES

- **Finished size:**
2300 x 800/850mm [inc. 200mm bleed]
- **Visual area:**
2090 x 800/850mm [top 10mm of graphic hidden by the mechanical hanger]

hex

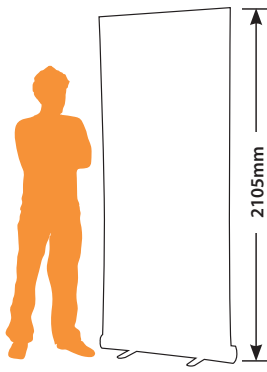

600mm footprint: 620 [w] x 320 [d]mm
800mm footprint: 820 [w] x 320 [d]mm
850mm footprint: 870 [w] x 320 [d]mm

1000mm footprint: 1020 [w] x 320 [d]mm
1200mm footprint: 1220 [w] x 320 [d]mm
1500mm footprint: 1520 [w] x 320 [d]mm

CODE	DESCRIPTION
91890	Hex 600mm wide
91891	Hex 800mm wide
91892	Hex 850mm wide
91893	Hex 1000mm wide
91894	Hex 1200mm wide
91895	Hex 1500mm wide

features

- Single-sided available in six widths
- Gripper rail top hanger
- Two twist out feet
- Strong fixed height, 3 part bungeed pole set*
- Compatible with Plex light fitting
- Padded carry bag included
- Individually boxed

*Hex 1200mm & 1500mm wide have 2 part bungeed pole set.

zeta

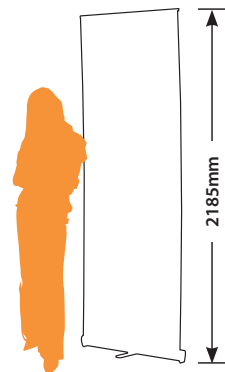

Footprint: 810 [w] x 320 [d]mm
Footprint: 860 [w] x 320 [d]mm

CODE	DESCRIPTION
91080	Zeta 800mm wide
91843	Zeta 850mm wide

features

- Budget roller banner
- 800/850mm wide, single-sided
- Visible graphic height to maximum 2090mm
- Mechanical style top hanger
- Tension adjustment
- Telescopic poles, adjust from 730mm to 2100mm
- Twist out foot
- Padded carry bag included
- Individually boxed

genie



CODE	DESCRIPTION
30241	Genie 800mm wide
90843	Genie 1000mm wide

features

- 800mm and 1000mm widths
- Single-sided
- Visible graphic height 2100mm
- Tension adjustment
- Fixed height bungeed pole set
- Quick change graphic facility
- Padded carry bag included
- Individually boxed



Quick change graphic facility.



Available in 800mm and 1000mm widths.

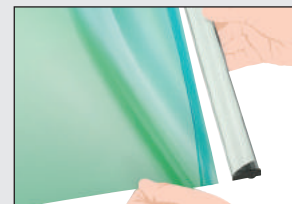

Gripper style top hanger.

GRAPHIC PANEL SIZES

- **Finished size:**
2315 x 800/1000mm
[inc. 200mm bleed]
- **Visual area:**
2100 x 800/1000mm
[top 15mm of graphic hidden by the top gripper rail]

sigma



CODE	DESCRIPTION
91444	Sigma 800mm wide
91739	Sigma 1000mm wide

features

- 800 and 1000mm widths, single-sided
- Telescopic poles adjust from 730 - 2100mm
- Mechanical style top hanger
- Tension adjustment
- Quick change graphic facility
- Weighted anti-slip base
- Padded carry bag included
- Individually boxed



Telescopic marked pole set.

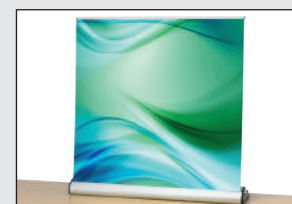

Can be used as a desktop system.

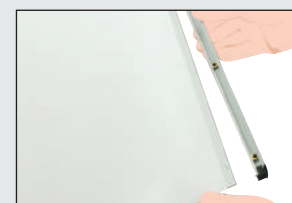

Mechanical hanger.

GRAPHIC PANEL SIZES

- **Finished size:**
2300 x 800/1000mm
[inc. 200mm bleed]
- **Visual area:**
2090 x 800/1000mm
[top 10mm of graphic hidden by the mechanical hanger]

NOTE: Hardware only no graphics included.



sidewinder

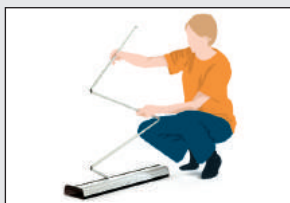

Integral bungeed pole set.



Adjustable tensioning [if required].



Available in single or double-sided options.

GRAPHIC PANEL SIZES

- **Finished size:**
2300 x 600/800/1000/1200/
1500mm [inc. 200mm bleed]
- **Visual area:**
2100 x 600/800/1000/
1200/1500mm



- **600mm footprint:** 617 [w] x 165 [d]mm
- **800mm footprint:** 817 [w] x 165 [d]mm
- **1000mm footprint:** 1017 [w] x 165 [d]mm
- **1200mm footprint:** 1217 [w] x 165 [d]mm
- **1500mm footprint:** 1517 [w] x 165 [d]mm

features and benefits

- Never lose your pole set again with Sidewinder's integral pole design
- A size option to suit any location. A truly versatile range of 5 widths – 600mm, 800mm, 1000mm, 1200mm and 1500mm wide. All sizes available as either single or double-sided
- Unique full graphic appearance - your message is the only thing you see when the system is assembled
- A deluxe carry bag with 30mm thick padded ends means the Sidewinder can be transported regularly without any worry of damage
- Self-adhesive top hanger
- The graphic can be changed quickly and easily due to the hook and loop fastener fixing method
- Fixed height poles allow the graphic to be rapidly set-up to the correct height every time
- The patented adjustable ratchet mechanism enables the graphic tension to be adjusted to suit each graphic substrate (if required)
- Anti-slip base
- Individually boxed



UK Patent No. WO 02/057588
No. PCT/GB02/00129 in USA

CODE	DESCRIPTION
463010	Sidewinder 600mm / single-sided
463011	Sidewinder 800mm / single-sided
463012	Sidewinder 1000mm / single-sided
463013	Sidewinder 1200mm / single-sided
463014	Sidewinder 1500mm / single-sided
463020	Sidewinder 600mm / double-sided
463021	Sidewinder 800mm / double-sided
463022	Sidewinder 1000mm / double-sided
463023	Sidewinder 1200mm / double-sided
463024	Sidewinder 1500mm / double-sided

PLEASE NOTE: Unattached pole set on 600mm version.

omega



Footprint: 875 [w] x 465 [d]mm

CODE	DESCRIPTION
30225/1	Omega fabric 780mm / grey fabric
30225/4	Omega fabric 780mm / blue fabric
30225/5	Omega fabric 780mm / black fabric
30225/7	Omega fabric 780mm / red fabric

features

- 780mm wide, single-sided
- Visible fabric height 2000mm
- Choice of four Velcro® friendly fabric colours (grey, blue, black and red)
- Fixed height bungeed pole set
- Customisable end trims
- Carry bag included
- 1m adhesive hook fastener included

TWO-YEAR WARRANTY



Customisable end trims.



Velcro® friendly fabric panels.

FABRIC COLOUR OPTIONS:

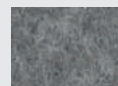

Chrome Grey

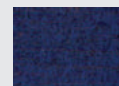

Sapphire Blue

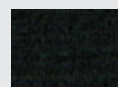

Charcoal Black



Chili Pepper Red



Fabric is manufactured from recycled materials.

FABRIC PANEL SIZES

- Visible fabric area: 2000 x 780mm

bantam



Footprint: 325 [w] x 78[d]mm

CODE	DESCRIPTION
91900	Bantam A3 desktop roller banner

features

- Single-sided A3 graphic size
- Aluminium base with chrome plated plastic ends
- 2 part steel pole
- Self-adhesive top rail and leader
- Individually boxed

ONE-YEAR WARRANTY



Perfect for counter display.

GRAPHIC PANEL SIZES

- Finished size: 297 x 435mm [inc. 15mm bleed]
- Visual area: 297 x 420mm

NOTE: Hardware only no graphics included.

staticbanners

QUICK REFERENCE GUIDE



PRODUCT SELECTOR

cobra

PRICE INDICATOR	£
VISUAL GRAPHIC AREA	2072 x 800mm
GRAPHIC ATTACHMENT METHOD	Gripping hangers
POLE TYPE	Telescopic

PAGE 10

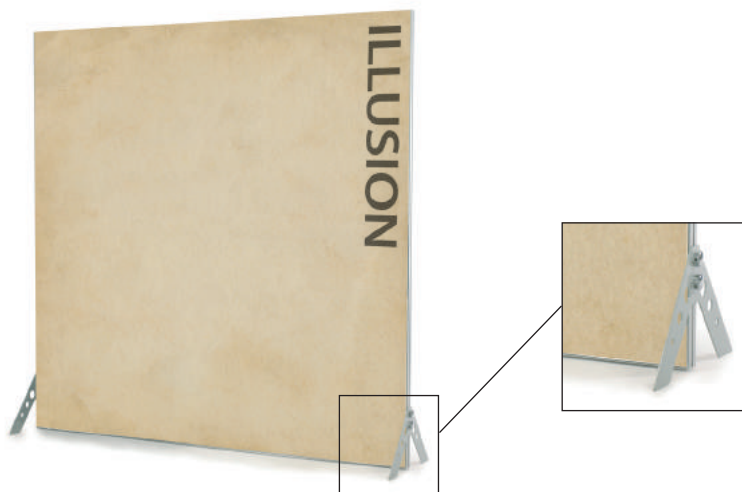

PRODUCT SELECTOR

illusion

PRICE INDICATOR	£ £ £ £
VISUAL GRAPHIC AREA	2000 x 2000mm
GRAPHIC ATTACHMENT METHOD	Stitched Silicone strip
FOOTPRINT	2040 [w] x 495 [d]mm

PAGE 10

NOTE: Hardware only no graphics included.

cobra

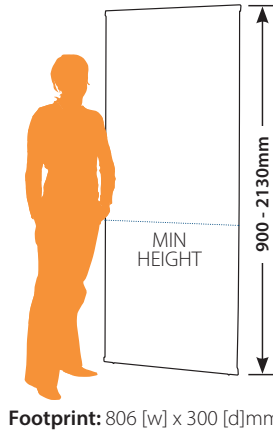

CODE	DESCRIPTION
91065	Cobra 800mm wide

features

- 800mm wide, single-sided
- Visible graphic height adjusts from 900mm up to 2000mm
- Adjustable telescopic pole set
- Gripper style top and bottom hangers
- Lightweight carry box included
- Can be used as a desktop system
- Assembled weight 2.0kg



Quick and easy graphic change with the gripper style hanger.



Adjustable telescopic pole set, can be used as desktop system.



Weighted base for added stability.

GRAPHIC PANEL SIZES

- **Finished size:** 2100 x 800mm
- **Visual area:** 2072 x 800mm [14mm hidden at the top and bottom by the gripper hangers]

illusion

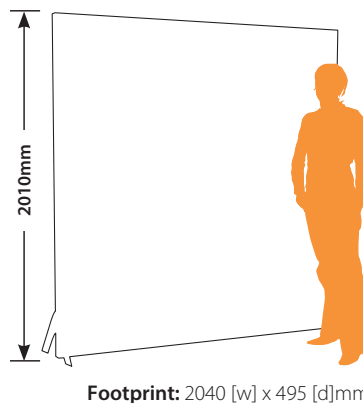

CODE	DESCRIPTION
91645	Illusion 2000mm wide
91657	Replacement graphic/ double-sided conversion silicone strip

features

- Visible graphic area 2000 x 2000mm
- Single-sided as standard
- Turn a single-sided kit into a double-sided by adding extra silicone strip
- Heavy steel triangular feet for stability
- Kit includes: frame, steel weighted feet and silicone graphic strip (enough for one graphic)
- Matt knitted polyester recommended substrate

NOTE: Hardware only no graphics included.



Push fit frame construction.



Corners assemble easily with an Allen key [supplied with kit].

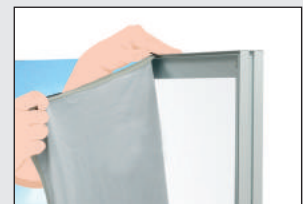

The silicone graphic strip sits tightly in the frame. Graphic stretches into place.

GRAPHIC PANEL SIZES

- **Finished size:** 2000 x 2000mm
- **Visual area:** 2000 x 2000mm

outdoor**banners**

QUICK REFERENCE GUIDE



cyclone

PRODUCT SELECTOR

PRICE INDICATOR

GRAPHIC WIDTH

HANGER TYPE

FOOTPRINT



2.7kg / 15.2kg

1990mm

800 [w] x 540 [d]mm

PAGE 12



polar



4.3kg / 22.3kg

1350 - 2150mm [telescopic]

650 - 800mm [w] x 400 [d]mm
[adjustable width]

PAGE 12



typhoon



15kg / 41kg

2170mm

1000 [w] x 780 [d]mm

PAGE 13



outdoor A-banner

PRODUCT SELECTOR

PRICE INDICATOR

GRAPHIC WIDTH

HANGER TYPE

FOOTPRINT



2000mm = 3.8kg / 3000mm = 5.5kg

960mm

2000mm = 2200 [w] x 650 [d]mm / 3000mm = 3190 [w] x 650 [d]mm

PAGE 13



vision



2000mm single-sided = 5.5kg / 3000mm single-sided = 7.2kg
2000mm double-sided = 8.5kg / 3000mm double-sided = 12.1kg

1100mm

2000mm = 2140 [w] x 990 [d]mm / 3000mm = 3160 [w] x 990 [d]mm

PAGE 14

cyclone

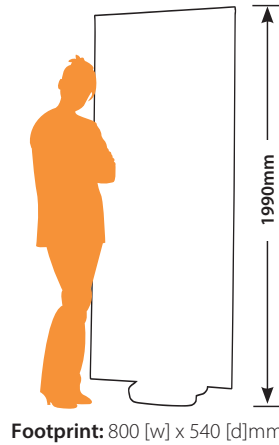
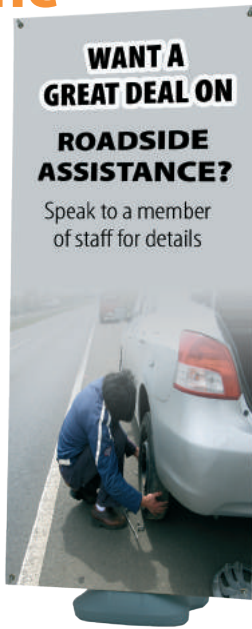

TWO-YEAR WARRANTY

CODE	DESCRIPTION
91558	Cyclone 800mm outdoor bannerstand
91282	Cyclone weighted base ring
91281	Cyclone carry bag set

features

- 800mm wide, single-sided
- Visual graphic height 1800mm
- Ideally suited to eyeletted PVC or mesh substrates
- Tensioned carbon rods

- 18 litre base capacity
- Weighted base ring available
- Optional carry bag set available

I Graphics suitable for outdoor use are recommended.



Moulded base can be filled with water or sand for added stability.



Tensioned carbon rod assembly.



Moulded hooks allow easy graphic attachment.

GRAPHIC PANEL SIZES

- **Finished size:**
1800 x 800mm
- **Visual area:**
1800 x 800mm

polar

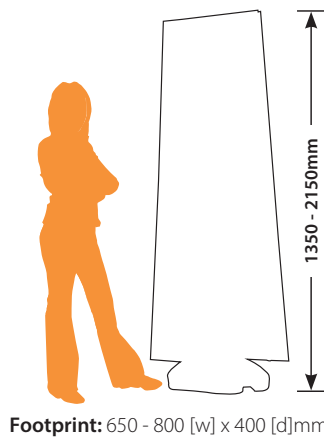

TWO-YEAR WARRANTY

CODE	DESCRIPTION
91240	Polar outdoor bannerstand
91282	Polar weighted base ring
91281	Polar carry bag set

features

- Adjustable graphic width from 650 to 800mm
- Adjustable graphic height from 1200 to 2000mm
- Single or double-sided option as standard
- Ideally suited to eyeletted PVC or mesh substrates

- 18 litre base capacity
- Optional carry bag set available
- Optional weighted base ring (10 litre capacity)

I Graphics suitable for outdoor use are recommended.

NOTE: Hardware only no graphics included.



Adjustable telescopic pole set.



Adjustable width graphic hangers.



Moulded plastic base can be filled with water or sand for extra stability. Optional weighted base ring is available.

GRAPHIC PANEL SIZES

- **Finished size:**
1200-2000 x 650-800mm
- **Visual area:**
1200-2000 x 650-800mm



Water/sand filled base with twist out foot for added stability.



Pull handle and integral wheels for easy transportation.



Wrap around slide-in self-adhesive hanger.

GRAPHIC PANEL SIZES

- **Finished size:**
2150 x 800mm
[inc. 100mm bleed]
- **Visual area:**
2000 x 800mm
[50mm hidden by the top gripper hanger]



Push fit parts give quick and easy assembly.

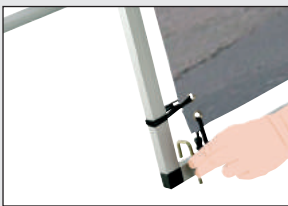

Ground pegs supplied as standard for use in soft ground.

GRAPHIC PANEL SIZES

- **Finished size:**
2000/3000 x 800mm
- **Visual area:**
2000/3000 x 800mm

typhoon

TWO-YEAR WARRANTY

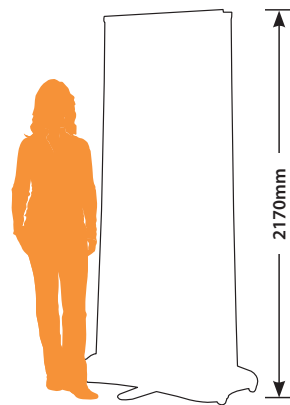

Footprint: 1000 [w] x 780 [d]mm



CODE	DESCRIPTION
91634	Typhoon 800mm outdoor roller bannerstand

features

- 800mm wide, single or double-sided outdoor roller banner
- Choice of visual graphic height either 1470 or 2000mm
- Wheeled base for easy manoeuvrability
- Two wrap around slide-in self-adhesive top hangers supplied as standard
- 26 litre base capacity
- Carry bag included

I Graphics suitable for outdoor use are recommended.

outdoor A-banner

ONE-YEAR WARRANTY

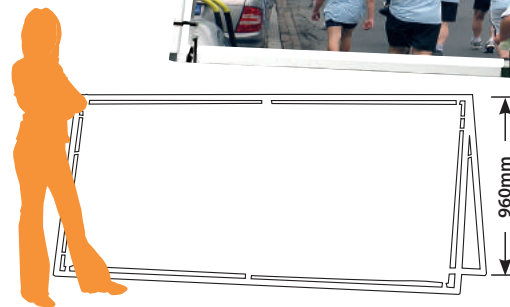

2m footprint: 2200 [w] x 650 [d]mm

3m footprint: 3190 [w] x 650 [d]mm

CODE	DESCRIPTION
91716	Outdoor A-banner 2m / single/double-sided
91717	Outdoor A-banner 3m / single/double-sided

features

- Two widths available – 2m and 3m
- 2m and 3m widths can be used as either single or double-sided
- Graphic height – 800mm
- Graphic width – 2000mm or 3000mm
- Push fit assembly
- Flexible bungee cord graphic attachment
- Ideally suited to eyeletted PVC or mesh substrates
- Carry bag included
- Ground pegs included

I Graphics suitable for outdoor use are recommended.

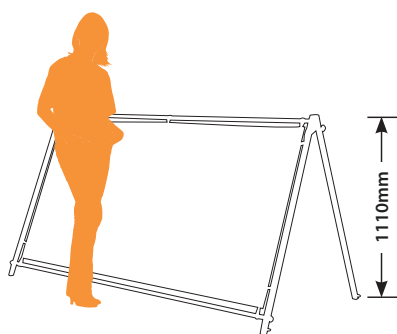

2m footprint: 2140 [w] x 990 [d]mm

3m footprint: 3160 [w] x 990 [d]mm

CODE	DESCRIPTION
91998	Vision 2000mm / single-sided
92000	Vision 2000mm / double-sided
91999	Vision 3000mm / single-sided
92001	Vision 3000mm / double-sided
91778	Carry Bag

features

- Screw fit, horizontal, anodised aluminium poles for increased rigidity
- Two widths available - 2m and 3m
- 2m and 3m wide available in both single or double-sided
- Graphic height - 1000mm
- Flexible bungee cord graphic attachment
- Ideally suited to eyeletted PVC or mesh substrates
- Graphics for outdoor use are recommended
- Optional carry bag available
- Ground pegs included
- Folds flat for easy storage

[!] Graphics suitable for outdoor use are recommended.



Robust screw fit assembly ideal for outdoor environments.

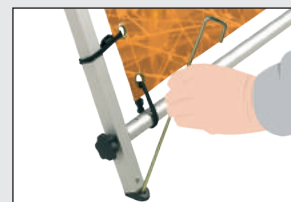

Ground pegs supplied as standard for use in soft ground.

GRAPHIC PANEL SIZES

- **Finished size:**
1000 x 2000/3000mm
- **Visual area:**
1000 x 2000/3000mm



NOTE: Hardware only no graphics included.

pop-upsystems

QUICK REFERENCE GUIDE

PRODUCT SELECTOR

PRICE INDICATOR

FRAME OPTIONS

KIT COMPONENTS

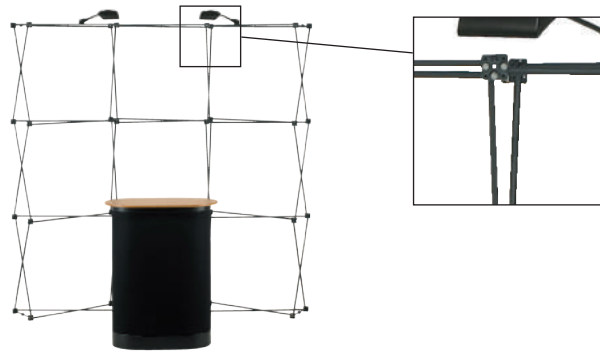

advantage curved



3x2, 3x3 and 3x4 curved

Frame, mag bars, hanging kits, rigidising strips, moulded wheeled rigid case, 2x flood lights, euro light adaptors, folding beech top, black fabric wrap and 30m roll of magnetic tape

PAGE 16



advantage straight



3x2, 3x3 and 3x4 straight

Frame, mag bars, hanging kits, rigidising strips, 2x stabilising feet, moulded wheeled rigid case, 2x flood lights, euro light adaptors, folding beech top, black fabric wrap and 30m roll of magnetic tape

PRODUCT SELECTOR

PRICE INDICATOR

FRAME OPTIONS

KIT COMPONENTS

PAGE 17

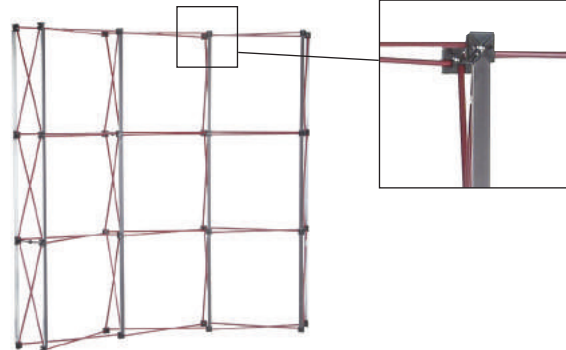

supremacy



3x3

Frame, mag bars, hanging kits, rigidising strips and moulded wheeled rigid case

PRODUCT SELECTOR

PRICE INDICATOR

FRAME OPTIONS

KIT COMPONENTS

PAGE 18

NOTE: Hardware only no graphics included.

advantage curved



THE COMPLETE ADVANTAGE BUNDLE

BUNDLE INCLUDES:

- Advantage frame
- Magnetic bars
- Hanging kits
- 2x 150W flood lights
- Durable wheeled case
- Beech folding top
- Fabric wrap for case
- Roll of magnetic tape

Just add graphics!



Fully magnetic pop-up frame including many extras.



Precision magnetic graphic attachment.



'Case to lectern' conversion kit and beech lectern top included as standard.

GRAPHIC PANEL SIZES

- **Inside curve:**
2130 x 653mm
- **Outside curve:**
2130 x 757mm
- **'D' end:**
2130 x 653mm

COMPONENTS REQUIRED TO CONVERT TO A DOUBLE SIDED DISPLAY.

	MAG BARS	REAR HANGING KITS
3 x 2	3	2
3 x 3	6	3
3 x 4	9	4

- 1 x 30m roll mag tape
- 2 x Vega lights

CODE	DESCRIPTION
91785	Advantage curved 3x2 pop-up bundle
30266	Advantage curved 3x3 pop-up bundle
30316	Advantage curved 3x4 pop-up bundle



assembled height

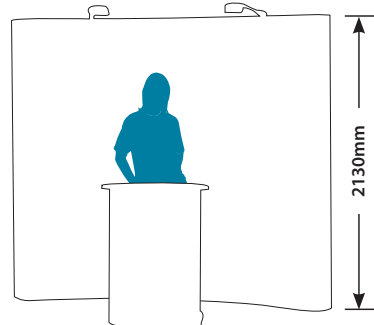

advantage dimensions

3x2 curved frame

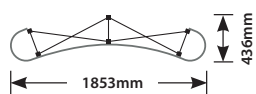

3x3 curved frame

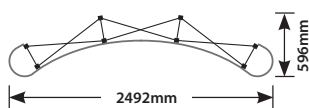

3x4 curved frame

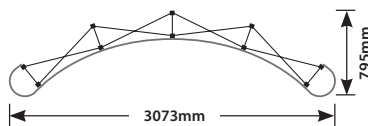

features

- Bundle available in 3x2, 3x3 and 3x4 curved configurations
- Visible graphic height 2130mm
- Hanging kits and additional mag bars available to dress rear of system

NOTE: Hardware only no graphics included.



Fully magnetic pop-up frame including many extras.



Precision magnetic graphic attachment.



'Case to lectern' conversion kit and beech lectern top included as standard.

GRAPHIC PANEL SIZES

- **Inside straight:**
2130 x 700mm
- **Outside straight:**
2130 x 700mm
- **'D' end:**
2130 x 653mm

COMPONENTS REQUIRED TO CONVERT TO A DOUBLE SIDED DISPLAY.

	MAG BARS	REAR HANGING KITS
3 x 2	3	2
3 x 3	6	3
3 x 4	9	4

- 1 x 30m roll mag tape
- 2 x Vega lights

advantage straight



THE COMPLETE ADVANTAGE BUNDLE

BUNDLE INCLUDES:

- Advantage frame
- Magnetic bars
- Hanging kits
- 2x Stabilising feet
- 2x 150W flood lights
- Durable wheeled case
- Beech folding top
- Fabric wrap for case
- Roll of magnetic tape

Just add graphics!



CODE	DESCRIPTION
91782	Advantage straight 3x2 pop-up bundle
91783	Advantage straight 3x3 pop-up bundle
91784	Advantage straight 3x4 pop-up bundle

assembled height

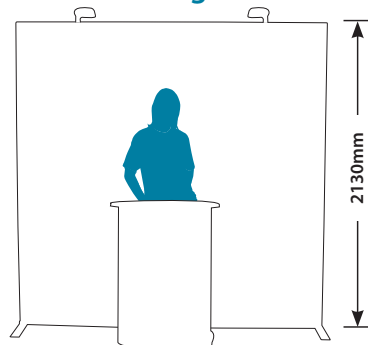

advantage dimensions

3x2 straight frame

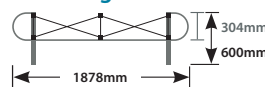

3x3 straight frame

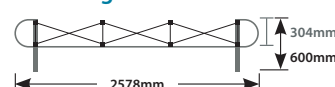

3x4 straight frame

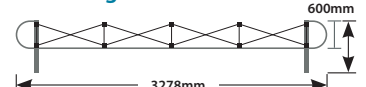

features

- Bundle available in 3x2, 3x3 and 3x4 straight configurations
- Visible graphic height 2130mm
- 2 front feet for stability
- Hanging kits and additional mag bars available to dress rear of system

NOTE: Hardware only no graphics included.

THE COMPLETE SUPREMACY BUNDLE

BUNDLE INCLUDES:

- Supremacy frame
 - Magnetic bars
 - Hanging kits
 - 2x 150W flood lights
 - Durable wheeled case
 - Roll of magnetic tape
- Just add graphics!*

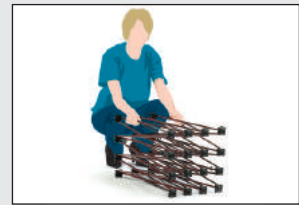

Concertina frame.



Self-locating magnetic bars.

CODE	DESCRIPTION
91961	Supremacy curved 3x3 pop-up complete bundle*
30006	Supremacy curved 3x3 pop-up frame kit only**
OPTIONAL EXTRAS	
90083/1	Corvus 150W flood light black
91457	Comet 85 case [850mm high]
90870	Advantage case
90871	Advantage black fabric case wrap (hook fastener receptive)
90872	Advantage lecturn top in beech
390025/5	30m Roll of magnetic tape

*Supremacy curved 3x3 pop-up bundle includes frame, 2x corvus lights, roll mag tape and 1x small comet case.

**Supremacy curved 3x3 pop-up frame with mag bars and hanging kits only.

GRAPHIC PANEL SIZES

- **Inside curve:**
2140 x 653mm
- **Outside curve:**
2140 x 758mm
- **'D' end:**
2140 x 600mm

COMPONENTS REQUIRED TO CONVERT TO A DOUBLE SIDED DISPLAY.

	MAG BARS	REAR HANGING KITS
3 x 3	6	3

- 1 x 30m roll mag tape
- 2 x Vega lights

assembled height

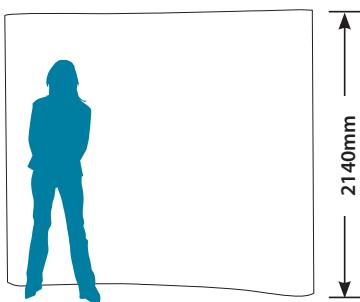

supremacy dimensions

3x3 curved frame

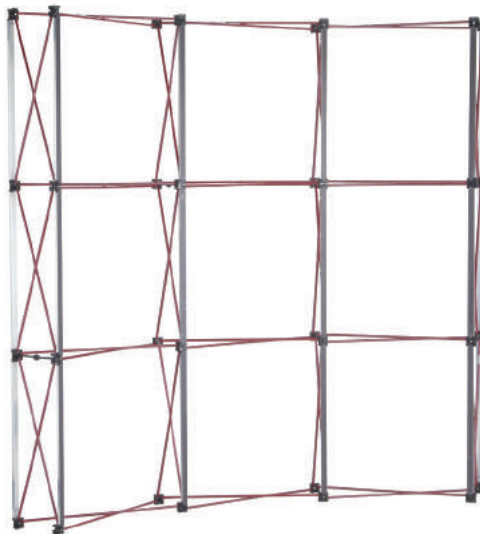
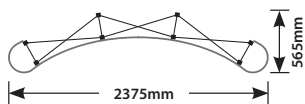

features

- Bundle available in 3x3 curved configurations
- Visible graphic height 2130mm
- Hanging kits and additional mag bars available to dress rear of system

NOTE: Hardware only no graphics included.

LORCESTER
UNIVERSITY
Open Day

CAMPUS TOURS

Hourly from 10am - 4pm
Building One: Main reception

SUBJECT PRESENTATIONS

Hourly from 10am - 4pm
Great Hall: Main reception

fusion rapid

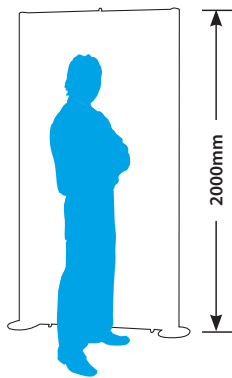

Post sections fit together effortlessly with our unique magnetic twist and lock.



Rigid graphic materials slide easily into the 8mm recessed frame.

CODE	DESCRIPTION
30295	Fusion rapid 1 straight frame system
30296	Fusion rapid 2 straight frame system
30297	Fusion rapid 3 straight frame system
40411	Carry case kit A – for use with Fusion rapid 1
40413	Carry case kit C – for use with Fusion rapid 2
40414	Carry case kit D – for use with Fusion rapid 3

features

- Post sections fit together effortlessly with our unique magnetic twist and lock
- Suitable for use with rigid panels (up to 8mm thick)
- Can be used single or double-sided
- Straight systems only, available as 1, 2 and 3 panel kits
- 2000mm high posts can be disassembled into 1000mm sections
- Each graphic panel is 1944 x 950mm
- Rapid system is compatible with the Versa system

*For footprint information see page 22.

GRAPHIC PANEL SIZES

- **Panel size:**
1944 x 950mm
N.B Any panel at 90° to standard post orientation requires 10mm deep by 15mm high notch in centre of panel edge
- **Substrate thickness:**
8mm – max.

fusion versa

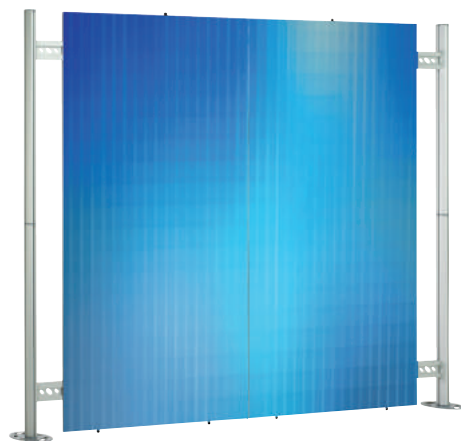
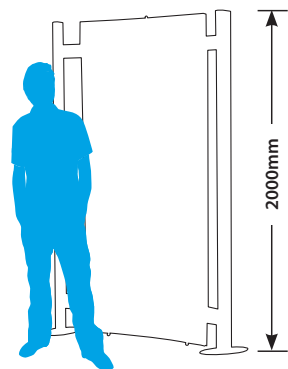

Flexible graphics magnetically attach to the aluminium framework.



Carry case kit – includes bag set and Comet wheeled case.

CODE	DESCRIPTION
30300	Fusion versa 1 straight frame system
30301	Fusion versa 2 straight frame system
30302	Fusion versa 3 straight frame system
30310	Fusion versa 1 curved frame system
30311	Fusion versa 2 curved frame system
30312	Fusion versa 3 curved frame system
40411	Carry case kit A – for use with Fusion versa 1 and 2 frame systems
40412	Carry case kit B – for use with Fusion versa 3 frame system
390025/S	30m roll of mag tape

features

- Post sections fit together effortlessly with our unique magnetic twist and lock
- Flexible graphics, suitable for use with straight or curved systems
- Rigid graphics only suitable for use with straight systems
- Can be used single or double-sided
- Straight or curved systems, available as 1, 2 and 3 panel kits
- Fusion Versa comes complete with fixing kits [single-sided only]
- Versa system can be used with the Rapid system
- Posts, frames and other spare parts available

*For footprint information see page 22. PLEASE NOTE: Mag tape is not included with Fusion kits.

GRAPHIC PANEL SIZES

- **Straight rigid panel:**
1941 x 945mm
- **Straight magnetic panel:**
2000 x 1000mm
- **Curved magnetic panel:**
2000 x 1000mm

fusion accessories

table kit



features

- 1m high post and base
- Silver laminated tabletop and associated fixings
- Suitable for use with Versa and Rapid systems

CODE	DESCRIPTION
90837	Table kit

literature unit



features

- A4 portrait configuration
- Easy post attachment
- Suitable for Versa and Rapid systems
- Left or right side fitting option

CODE	DESCRIPTION
80276	A4 literature unit / left side fixing
80275	A4 literature unit / right side fixing

LCD/iPad bracket



features

- Fixed bracket
- Holds maximum weight of 15kg or 30" LCD display
- Add an iPad with our mounting enclosure (see page 49)
- VESA mounting compliant [75, 100mm]
- Suitable for Versa and Rapid systems

CODE	DESCRIPTION
40362	LCD bracket
91957	Black iPad lockable enclosure
91958	White iPad lockable enclosure

carry equipment



features

- Rotator moulded lockable transportation cases
- Wheels for easy transportation
- Holds fusion kit bags
- Bags supplied as part of kit
- See page 20 for Fusion kit options

CODE	DESCRIPTION
40411	Fusion carry case kit A
40412	Fusion carry case kit B
40413	Fusion carry case kit C
40414	Fusion carry case kit D

additional fusion accessories

CODE	DESCRIPTION
90678	Fusion graphic hanger
80294	Fusion steel tape (pack of 6 - 2 short and 4 long)
80290	Fusion magnetic twist lock 2m post kit
80269	Fusion base (oval) - finished
80273	Fusion rapid straight frame kit

CODE	DESCRIPTION
80274	Fusion versa post to frame joining kit (pair)
80271	Fusion versa straight frame kit
80272	Fusion versa curved frame kit
91545	Fusion base bag for oval base (holds 2 bases)
90900	Fusion post/frame bag (holds 1 post or 1 versa frame kit)

NOTE: Hardware only no graphics included.

fusionfootprints

fusion rapid

fusion rapid

1 panel straight



2 panel straight

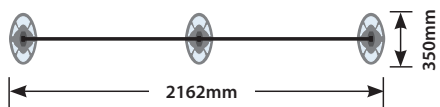

3 panel straight

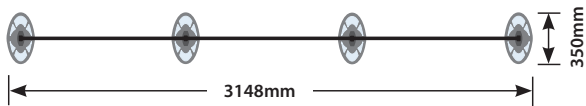

fusion table kit

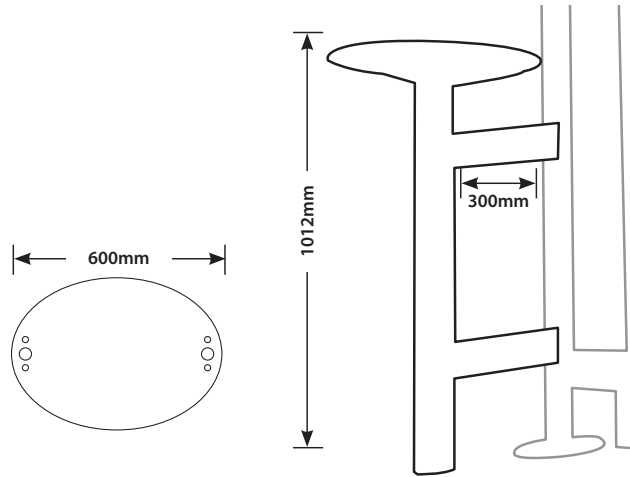

fusion versa

curved configurations

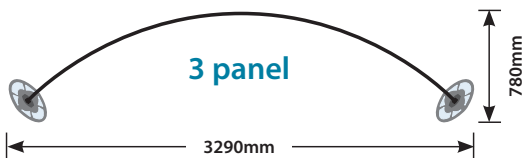

straight configurations

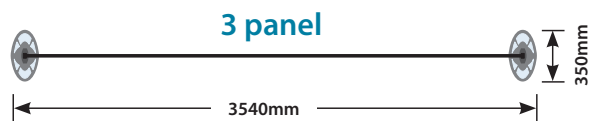
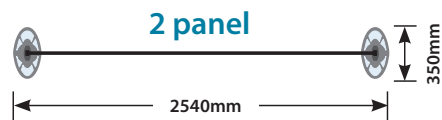
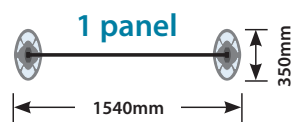

folding panel kits



16mm hard wearing PVC frame.



360° hinge.

FABRIC PANEL SIZES

- **Mini table top kit panel sizes:**
600 x 900mm,
[2x] 600 x 450mm and
200 x 900mm
- **Maxi table top kit panel sizes:**
[3x] 900 x 600mm and
200 x 600mm
- **PK511 kit panel sizes:**
[6x] 900 x 600mm and
200 x 600mm

STOCKED FABRIC COLOURS:



Cherry/Alpha red

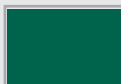

Emerald green

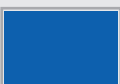

Royal blue



Dove/Light grey

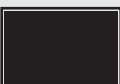

Black



Grey/Blue



PK51 – Mini table top kit.



PK52 – Maxi table top kit.

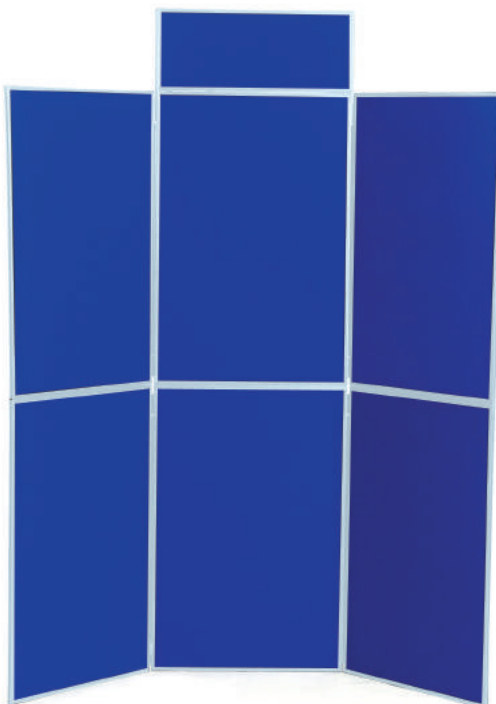

PK511 – 6 panel folding kit.

stocked kits

CODE	DESCRIPTION
PK51/3	Mini table top kit and carry bag
PK52/3	Maxi table top kit and carry bag
PK511/3	6 panel folding kit inc. header panel and carry bag

features

- Frame colour option – grey [N.B. Black fabric kit supplied with black frame as standard]
- Double-sided, reversible, free standing, hinged lightweight kits
- Individual panel size 900 x 600mm surrounded by a 16mm hard wearing PVC frame
- The loop nylon covering is fire retardant to BS 5867

*Choose frame colour and fabric colour at time of ordering.

NOTE: Hardware only no graphics included.

literaturestands

QUICK REFERENCE GUIDE



onyx

PRODUCT SELECTOR

PRICE INDICATOR

CAPACITY

HEIGHT

FOOTPRINT



6x A4 portrait shelves

1244mm

330 [w] x 420 [d]mm

PAGE 25



media compact portrait



6x A4 portrait shelves

1475mm

280 [w] x 290 [d]mm

PAGE 25



media 4 deluxe

PRODUCT SELECTOR

PRICE INDICATOR

CAPACITY

HEIGHT

FOOTPRINT



4x A4 portrait shelves

1520mm

260 [w] x 280 [d]mm

PAGE 26



promotion unit



One internal shelf with integrated base

OVERALL HEIGHT - Small 2004mm, Large 2205mm

WORKTOP HEIGHT - Small 858mm, Large 2205mm

Small 810 [w] x 470 [d]mm

Large 860 [w] x 540 [d]mm

PAGE 26

NOTE: Hardware only no graphics included.



1 piece frosted insert with 6 x A4 portrait 48mm pockets.



Contemporary design.

onyx

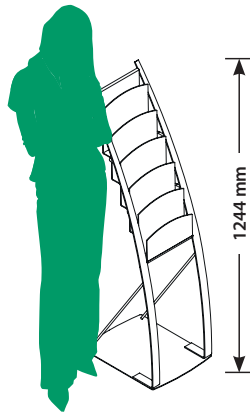

Footprint: 330 [w] x 420 [d]mm



CODE	DESCRIPTION
91925	Onyx

features

- Stylish contemporary design
- 1 piece frosted insert with 6 x A4 portrait 48mm pockets
- Sturdy black ready assembled frame
- Promotion or decoration space below
- 4 anti-slip feet



Aluminium case.



Hinged locking mechanism.

media compact portrait

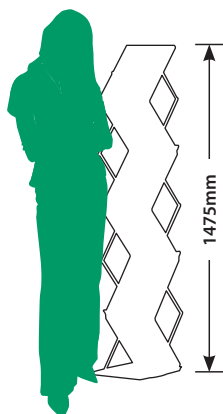

Footprint: 280 [w] x 290 [d]mm



CODE	DESCRIPTION
90482	Media compact portrait

features

- Collapsible A4 portrait literature holder
- Single or double-sided
- 6 x A4 portrait shelves 25mm deep (8mm deep bottom shelf)
- Steel and aluminium frame
- Transparent acrylic shelving
- Supplied with an aluminium case

NOTE: Hardware only no graphics included.

media 4 deluxe

TWO-YEAR WARRANTY

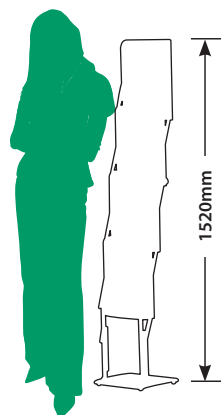

Footprint: 260 [w] x 280 [d]mm



Reinforced carry bag.



Locking mechanism.

CODE	DESCRIPTION
90996	Media 4 deluxe

features

- Collapsible portrait literature holder
- Single-sided
- 4 x 40mm deep A4 portrait literature pockets
- Chrome base
- Virtually unbreakable Polycarbonate pockets
- Supplied with a reinforced carry bag

promotion unit

TWO-YEAR WARRANTY

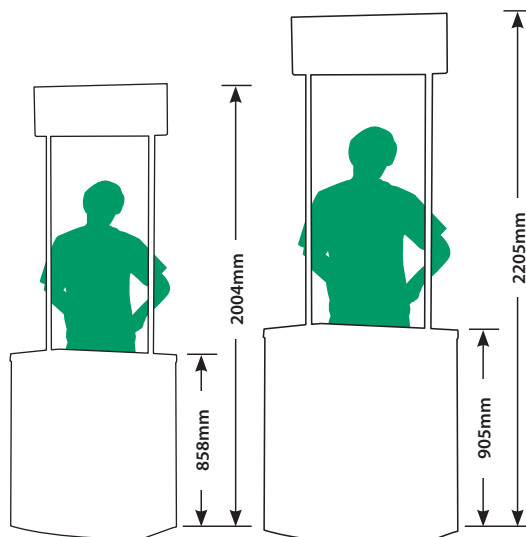

Small Footprint: 810 [w] x 470 [d]mm
Large Footprint: 860 [w] x 540 [d]mm



Flat pack assembly.



Handy internal storage shelf and base.

CODE	DESCRIPTION
91995	Small promotion unit with header, double pole set and bag
91996	Large promotion unit with header, double pole set and bag

features

- One internal shelf with integrated base for maximum storage
- Double pole set x 2 and header
- Folds flat for easy transportation
- Supplied with carry bag
- Robust but lightweight
- Easy to add graphics for instant branding
- Wipe clean PVC surface

NOTE: Hardware only no graphics included.

GRAPHIC PANEL SIZES

Header panel

- Visual area:
Small - 280 x 770mm
Large - 300 x 800mm

Base unit

- Overall size:
Small - 2004mm [h] x 810mm [w] x 470mm [d]
Large - 2205mm [h] x 860mm [w] x 540mm [d]

• Visual area of front:

- Small - 823 [w] x 785 [h]mm [33mm is hidden by both the top and bottom of the unit]
- Large - 878 [w] x 820 [h]mm [38mm is hidden by both the top and bottom of the unit]



lighting

sirius: 50 watt mains spotlight



Also available in a satin chrome finish.



Straight arm plex light fitting.



Curved arm universal banner pole clamp.



Chrome finish.

- 50W mains spotlight
- Chrome or satin chrome finishes
- Supplied complete with Plex light fitting or universal banner pole clamp
- GU10 bulb - 50W - compatible with LED bulbs

CODE	DESCRIPTION
91317	Sirius / satin chrome - straight arm plex light fitting
91317/9	Sirius / chrome - straight arm plex light fitting
91829	Sirius curved arm / satin chrome - with universal banner pole clamp
91829/9	Sirius curved arm / chrome - with universal banner pole clamp

*See page 29 for lighting options guide.



Curved arm universal roller banner clamp.

LIGHTING SIZES

Sirius Straight Arm

- Length: 400mm

Sirius Curved Arm

- Length: 450mm

Polaris Arm

- Length: 400mm

Vega Arm

- Length: 260mm

polaris: 50 watt mains spotlight



Also available in a silver finish.



Straight arm plex light fitting.



Black finish.

- 50W mains spotlight
- Silver and black finishes
- Supplied complete with Plex light fitting
- GU10 bulb - 50W - compatible with LED bulbs

CODE	DESCRIPTION
91316/1	Polaris / black - with plex light fitting
91316/9	Polaris / silver - with plex light fitting

*See page 29 for lighting options guide.

vega: 150 watt mains floodlight



Also available in a silver finish.



Pop-up cross arm fitting.



Black finish.

CODE	DESCRIPTION
90715	Vega / black
90715/9	Vega / silver

- 150W Halogen flood light
- Silver and black finishes
- Supplied complete with pop-up frame fitting
- Halogen linear R7 bulb - 78mm - 150w

lighting options

	SIRIUS 50 W spotlight STRAIGHT ARM with light fitting	SIRIUS 50 W spotlight CURVED ARM with universal banner clamp	POLARIS 50 W spotlight STRAIGHT ARM with light fitting	VEGA 150 W floodlight STRAIGHT ARM with pop-upcross arm fitting
ROLLER BANNERS				
Atom		●		
Zeta	●	●	●	
Neo		●		
Hex	●	●	●	
Genie	●	●	●	
Sigma	●	●	●	
Sidewinder	●	●	●	
Omega	●		●	
STATIC BANNERS				
Cobra	●	●	●	
Illusion	●		●	
POP-UPS				
Supremacy				●
Advantage Curved				●
Advantage Straight				●
MODULAR DISPLAYS				
Fusion Rapid	●		●	
Fusion Versa	●		●	

PLEASE NOTE: All lights have **CE marking** and are **ROHS compliant**.

pop-up/fusion cases

comet case



Comet 85 case [with 3x4 pop-up system including fixings and graphics].



Comet 115 case [with Fusion kit bags].

CODE	DESCRIPTION
91457	Comet small pop-up case [850mm high]
91458	Comet large fusion case [1150mm high]
40411	Fusion carry case kit A - 1x large comet case, 1x base bag, 3x frame bags
40412	Fusion carry case kit B - 2x large comet cases, 1x base bag, 4x frame bags
40413	Fusion carry case kit C - 1x large comet case, 2x base bags, 4x frame bags
40414	Fusion carry case kit D - 2x large comet cases, 2x base bags, 5x frame bags

features

- Rotationally moulded lockable transportation cases
- Holds pop-up frame with fixtures and single sided graphics upto 3x4 frame
- Wheels for easy transportation
- Available in 850mm and 1150mm internal heights, 350mm internal diameter
- Holds fusion kit bags and graphics

advantage case



Advantage case packed with a pop-up kit and graphics.



Advantage case lighting compartment in the lid.

CODE	DESCRIPTION
90870	Advantage case
90871	Black fabric case wrap (hook fastener receptive)
90872	Lectern top in beech

features

- Rotationally moulded wheeled, lockable transportation case
- Complete with lighting compartment in the lid
- Suitable for transporting up to a 3x4 pop-up frame and graphics

panel and accessory bags



CODE	DESCRIPTION
707010	900 x 600mm panel standard carry bag [160mm bag depth]

features

- Standard carry bags are supplied with webbing handles and shoulder straps
- Lightweight and foldable



Case holds 2 x 800mm Genie bannerstands.



Case holds 1 x 800mm Sidewinder bannerstand and 1 x 50W spotlight.

bannerstand transit case



CODE	DESCRIPTION
91023	Genie/Zeta/Sidewinder/Sigma 800mm bannerstand case

features

- Textured aluminium finish and stylish chrome reinforced rounded corners
- 800mm case holds 2 x 800mm Genies, 3 x Zetas or 1 x 800mm Sidewinder or 1 x 800mm Sigma

NOTE: Hardware only no graphics included.



pavementsignage

QUICK REFERENCE GUIDE



PRODUCT SELECTOR

sign wedge

folding swing sign

classic swing sign

switch swing sign

PRICE INDICATOR	£	£	£ £	£ £
WEIGHT	6.1kg	5.9kg	10.5kg	10.5kg
HEIGHT	795mm	846mm	915mm	915mm
FOOTPRINT	420 [w] x 420 [d]mm	585 [w] x 585 [d]mm	585 [w] x 460 [d]mm	585 [w] x 460 [d]mm

PAGE 34

PAGE 34

PAGE 35

PAGE 35



PRODUCT SELECTOR

aquabase prime

aquabase swap

A-frame

PRICE INDICATOR	£ £ £	£ £ £	£ £
WEIGHT	11.0kg 41.0kg with water	11.0kg 41.0kg with water	A0 = 17kg / A1 = 10.5kg / A2 = 6.8kg
HEIGHT	1215 mm	1215mm	A0 = 1445mm / A1 = 1165mm / A2 = 985mm
FOOTPRINT	740 [w] x 610 [d]mm	740 [w] x 610 [d]mm	A0 = 883 [w] x 805 [d] / A1 = 625 [w] x 670 [d] / A2 = 465 [w] x 680 [d]mm

PAGE 36

PAGE 36

PAGE 37

sign wedge

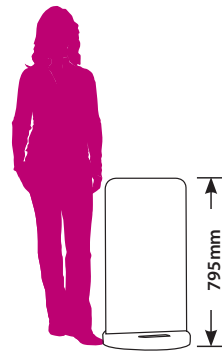

Footprint: 420 [w] x 420 [d]mm

CODE	DESCRIPTION
40398	Sign wedge
80263	Replacement sign blank

features

- Double-sided graphic area
- White printable aluminium sign blank
- Printable graphic area 740 x 410mm
- Recycled PVC base
- Quick and easy assembly, no tools required
- Hand holes in base
- Graphic friction fits into base

Graphics suitable for outdoor use are recommended.

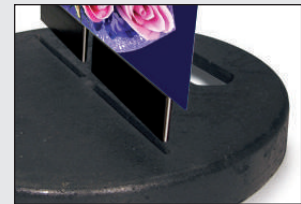

Aluminium graphic panel friction fits into base.



Heavy duty circular recycled PVC base with hand holes for easy transportation.

GRAPHIC PANEL SIZES

- **Blank size:**
780 x 410mm [top corners have a radius of 50mm]
- **Visual area:**
740 x 410mm [top corners have a radius of 50mm]

folding swing sign



Visit www.youtube.com/PlexDisplayLimited for instruction videos.

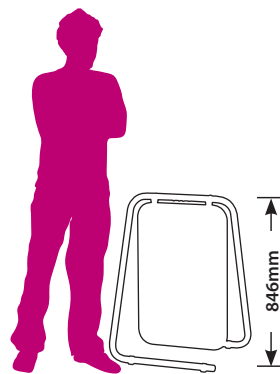

Footprint: 585 [w] x 585 [d]mm

CODE	DESCRIPTION
91753	Folding swing sign
80267	Replacement sign blank

features

- No assembly required
- Folds flat for storage
- Easy to handle when folded flat
- White printable aluminium sign blank
- Printable graphic area 750 x 500mm
- Simple, yet sturdy design

Graphics suitable for outdoor use are recommended.

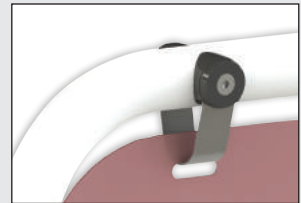

Stainless steel tamper proof hanging clips.



Spring button allows frame to fold flat.

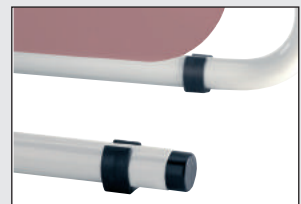

Robust black plastic feet.

GRAPHIC PANEL SIZES

- **Blank size:**
750 x 500mm [corners have a radius of 75mm]
- **Visual area:**
750 x 500mm [corners have a radius of 75mm]



Frames available in white, black or grey.

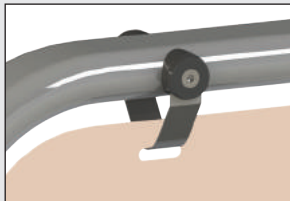

Stainless steel tamper proof hanging clips.



Robust frame secures into heavy duty recycled PVC Base.

GRAPHIC PANEL SIZES

- **Blank size:**
750 x 500mm [corners have a radius of 75mm]
- **Visual area:**
750 x 500mm [corners have a radius of 75mm]



Magnetic poster pocket holds A2 graphic posters.



Frames available in white, black or grey.

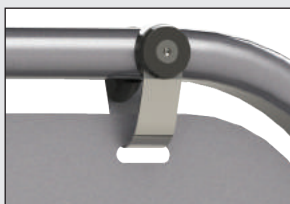

Stainless steel tamper proof hanging clips.

GRAPHIC PANEL SIZES

- **Poster size:**
A2 – 594 x 420mm
- **Visual area:**
575 x 400mm

classic

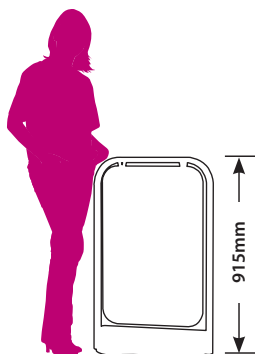

Footprint: 585 [w] x 460 [d]mm



CODE	DESCRIPTION
40404	Classic swing sign / white frame
40405	Classic swing sign / black frame
91817	Classic swing sign / grey frame
80267	Replacement sign blank

features

- Double-sided graphic area
- White printable aluminium sign blank
- Printable graphic area 750 x 500mm
- Frame available in white, black or grey
- Recycled PVC base
- Quick and easy assembly, no tools required

I Graphics suitable for outdoor use are recommended.

switch

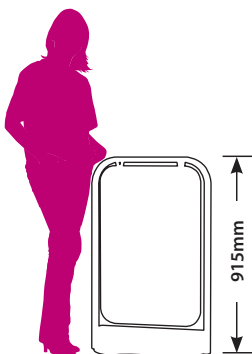

Footprint: 585 [w] x 460 [d]mm



Option to mix'n'match frame and pocket colours contact us for details

CODE	DESCRIPTION
40402	Switch swing sign / white frame / white poster pocket
40403	Switch swing sign / black frame / black poster pocket
91818	Switch swing sign / grey frame / grey poster pocket

features

- Double-sided magnetic A2 poster pocket with printable header section
- Frame and poster pocket available in white, black or grey
- Houses A2 poster (594 x 420mm)
- Recycled PVC base
- Quick and easy assembly, no tools required

I Graphics suitable for outdoor use are recommended.

NOTE: Hardware only no graphics included.

aquabase prime



YouTube Visit www.youtube.com/PlexDisplayLimited for instruction videos.

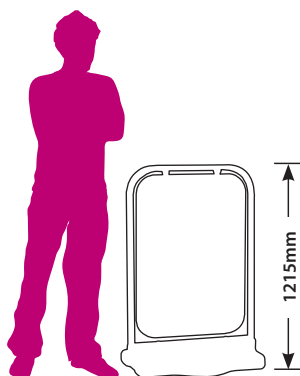

Footprint: 740 [w] x 610 [d]mm

CODE	DESCRIPTION
91819	Aquabase prime / white frame
91820	Aquabase prime / black frame
91821	Aquabase prime / grey frame
91811	Replacement sign blank

features

- Double-sided graphic area
- White printable aluminium sign blank
- Printable graphic area 990 x 640mm
- Quick and easy assembly
- Frame available in white, black or grey
- Robust frame and water fillable base give great stability even in adverse weather conditions
- Wheels in base allow unit to be manoeuvred into position
- Base capacity 30 litres

I Graphics suitable for outdoor use are recommended.



Stainless steel tamper proof hanging clips.



Wheeled base for easy manoeuvrability.



Water or sand can be used to fill base.

GRAPHIC PANEL SIZES

- **Blank size:**
990 x 640mm [corners have a radius of 75mm]
- **Visual area:**
990 x 640mm [corners have a radius of 75mm]

aquabase swap



Option to mix'n'match frame and pocket colours contact us for details

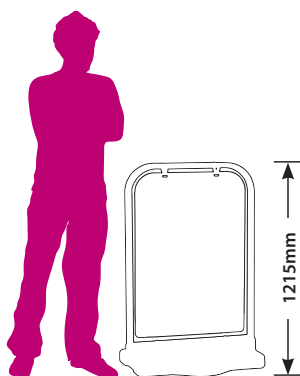

Footprint: 740 [w] x 610 [d]mm

CODE	DESCRIPTION
91814	Aquabase Swap swing sign / white frame
91815	Aquabase Swap swing sign / black frame
91816	Aquabase Swap swing sign / grey frame

features

- Double-sided magnetic A1 poster pocket (841 x 594mm) with printable header section
- Frame and poster pocket available in three colours: white, black and grey
- Quick and easy assembly
- Robust frame and water fillable base give great stability even in adverse weather conditions
- Wheels in base allow unit to be manoeuvred into position
- Base capacity 30 litres

I Graphics suitable for outdoor use are recommended.



Magnetic poster pocket holds A1 graphic or poster.



Stainless steel tamper proof hanging clips.



Wheeled base for easy manoeuvrability.

GRAPHIC PANEL SIZES

- **Poster size:**
A1 - 841 x 594mm
- **Visual area:**
814 x 575mm



Rounded chrome corners.



Secure locking arms.

A-frame

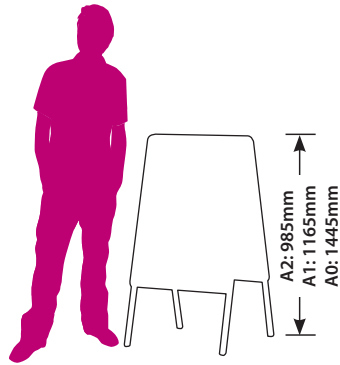

A2 footprint: 465 [w] x 680 [d]mm

A1 footprint: 625 [w] x 670 [d]mm

A0 footprint: 883 [w] x 805 [d]mm



GRAPHIC PANEL SIZES

• Finished size:

- A2 – 594 x 420mm
- A1 – 841 x 594mm
- A0 – 1189 x 841mm

• Visual area:

- A2 – 574 x 400mm
- A1 – 821 x 574mm
- A0 – 1169 x 821mm

CODE	DESCRIPTION
90621	A2 A-frame / double-sided
90620	A1 A-frame / double-sided
90619	A0 A-frame / double-sided

features

- Double-sided
- Easy change snapframe mechanism securely holds posters in place
- Galvanised steel backing adds weight and strength
- Houses posters in A0 (1189 x 841mm), A1 (841 x 594mm) and A2 (594 x 420mm)
- 32mm wide aluminium snapframe
- Comes complete with protective front corners

I Graphics suitable for outdoor use are recommended.



NOTE: Hardware only no graphics included.

H. Hollinworths

2 MEALS
FOR ONLY **£12**



plex



forecourtsignage

QUICK REFERENCE GUIDE



**A1 H2O
swingmaster**

**PRODUCT
SELECTOR**

PRICE INDICATOR



GRAPHIC SIZE

A1 = [841 x 594mm]

DIMENSIONS

A1 = 1150 [h] x 780 [w] x 500 [d]mm

BASE CAPACITY

A1 = 26 litres

PAGE 40



**A0 H2O
swingmaster**



A0 = [1189 x 841mm]

A0 = 1530 [h] x 1030 [w] x 650 [d]mm

A0 = 50 litres

PAGE 40



icon

**PRODUCT
SELECTOR**

PRICE INDICATOR



GRAPHIC SIZE

A1 = [841 x 594mm]

DIMENSIONS

A1 = 1215 [h] x 740 [w] x 610 [d]mm

BASE CAPACITY

A1 = 30 litres

PAGE 41



icon plus



A0 = [1189 x 841mm]

A0 = 1633 [h] x 986 [w] x 841 [d]mm

A0 = 70 litres

PAGE 41



icon max



60" x 40" = [1016 x 1524mm]

60" x 40" = 2006 [h] x 1161 [w] x 1000 [d]mm

60" x 40" = 108 litres

PAGE 41

H2O swingmaster



Posters are secured by 32mm aluminium snapframe profile.



Wheeled base for easy manoeuvrability.



Weighted base can be filled with water or sand for extra stability.

CODE	DESCRIPTION
91708	A1 H2O swingmaster
91945	A0 H2O heavy duty swingmaster

GRAPHIC PANEL SIZES

- **Finished size:**
A1 – 841 x 594mm
A0 – 1189 x 841mm
- **Visual area:**
A1 – 827 x 580mm
A0 – 1175 x 827mm



features

- Double-sided outdoor forecourt sign, available in two sizes, A0 and A1
- Steel reinforced rounded corners, heavy duty A0
- Protective pads stop damage to underside of base
- Quick and easy assembly, no tools required
- Wheels in base allow unit to be manoeuvred into position
- Water fillable base gives great stability even in adverse weather conditions
- Base capacity; A1 – 26 litres and A0 – 50 litres

Graphics suitable for outdoor use are recommended.

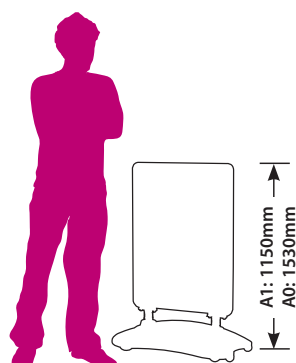

A1 footprint: 780 [w] x 500 [d]mm
A0 footprint: 1030 [w] x 650 [d]mm

features for all icons

-
- Tough polyethylene moulded header with graphic recess.
 - Poster hanging clips - hold poster in correct position.
 - Strong steel frame.
 - Built in wheels for ease of movement. Optional trolley available for Max and Plus size.
 - Tough water-fillable polyethylene base.
 - Unique hinged poster cover - allows quick poster changes.
 - Your communication here.
 - Poster insertion instructions printed onto backboard.
 - Recyclable at end of life, part manufactured from recycled materials.
 - Anti-scuff features designed into underside of base.

icon



icon plus



icon max

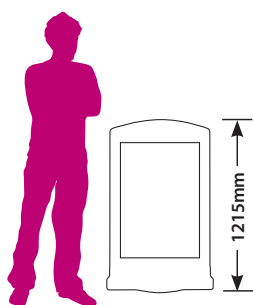

Footprint: 740 [w] x 610 [d]mm

ADDITIONAL FEATURES FOR ICON

- 50kg Assembled weight - when base filled with water
- Steel galvanised backboard

GRAPHIC PANEL SIZES

- Finished size: 841 x 594mm
- Visual area: 814 x 577mm

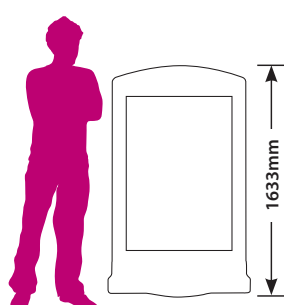

Footprint: 986 [w] x 814 [d]mm

ADDITIONAL FEATURES FOR ICON PLUS

- 102kg Assembled weight - when base filled with water
- Strong, but lightweight corrugated plastic backboard

GRAPHIC PANEL SIZES

- Finished size: 1189 x 841mm
- Visual area: 1162 x 824mm

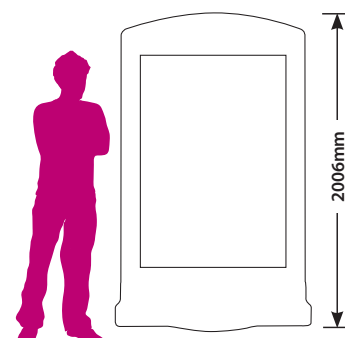

Footprint: 1161 [w] x 1000 [d]mm

ADDITIONAL FEATURES FOR ICON MAX

- 151 kg Assembled weight - when base filled with water
- Strong, but lightweight corrugated plastic backboard

GRAPHIC PANEL SIZES

- Finished size: 60" x 40" (1524 x 1016mm)
- Visual area: 1497 x 999mm

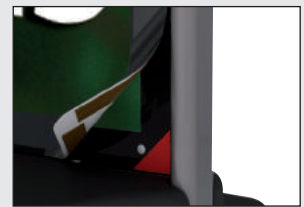

Hinged magnetic poster pocket enables graphics to be changed easily without the need for tools.



Wheeled base can be filled with sand or water for extra stability.



Recessed header for individual or corporate branding.



Poster hanging clips, holds poster in correct position.



Screw in water filler cap.



Optional trolley for Icon max and Icon plus sizes.



CODE	DESCRIPTION
30333	Icon A1 sign
92050	Icon plus A0 sign
91930	Icon max "60 x 40" sign
91931	Wheeled trolley for Icon max and Icon plus

ten good reasons to choose an icon

1. Robust, high specification design for many years of trouble free advertising.
2. Simple for staff to strategically position promotions in high traffic areas.
3. Quick and easy to change posters - a one person job.
4. Modern; engaging; attention grabbing looks for maximum impact.
5. Excellent value for money and outstanding return on investment when compared to other more traditional signs.
6. Can also be used in-store to emphasis additional services.
7. Expose more customers to YOUR sales promotions.
8. Fits in with your environmental credentials - all parts are fully recyclable.
9. Extremely stable, even in severe weather conditions.
10. No loose parts that can get lost or broken.

NOTE: Hardware only no graphics included.



FREELANDER 2 2.2 TD4 S



VEHICLE DETAILS

Overview	Manual
Registration	Mar 2007
Make	220
Mileage	22000
Colour	Dark Blue
Interior	Marine Blue
Price	

*MSRP (including VAT and delivery)

APPROVED USED VEHICLE PROGRAMME BENEFITS

- 12 months Land Rover warranty
- 22 months Land Rover assistance
- 12 months accident management service
- Comprehensive pre-sale inspection
- Certificate of sale and history check
- 30 day or 1000 mile exchange policy

FITTED EQUIPMENT

- 18" alloy wheels
- 50-amp battery
- ABS lock braking system
- Burgers 2-in-1 alloy cycle
- Corner Brake Control (CBC)
- Driver & passenger air bags
- Driver air bag
- Driver & front passenger centre
- Dynamic Stability Control (DSC)
- Electric windows
- Electronic Brake Assist (EBA)
- Electronic Brake Force Distribution (EBF)
- Electronic Traction Control (ETC)
- Engine Drag Control (EDC)
- Front airbags
- Hill Descent Control (HDC)
- Passenger air bag moment centre
- Permanent four wheel drive
- Power windows
- Remote central locking
- Roll Stability Control (RSC)
- Single CD player
- Valves and pressure valves

TECHNICAL SPECIFICATION*

ENGINE & PERFORMANCE		DIMENSIONS & CAPACITIES		PHYSICAL CAPABILITIES	
Engine Type	Common Rail 4 cylinder	Overall Length	4500 mm	Load & Luggage Capacity	
Transmission	4-Speed manual	Overall Width	2180 mm	Towing	
Maximum Power	120PS @ 4,200 rpm	Overall Height	1740 mm	Min. Turning Radius	11.3 m
Maximum Speed	157 mph	Wheelbase	2680 mm	Approach Angle	26 degrees
Acceleration 0-60mph	11.7 secs	Land Rover WOT	52.9 mph	Ramp Angle	22 degrees
Urban Cycle	30.4 mpg	Max Weight (incl. trailer)	3500 kg	Departure Angle	34 degrees
Extra Urban Cycle	42.5 mpg	Max Weight (incl. trailer)	3500 kg		
Combined	37.7 mpg	Luggage Capacity	760 (500)		
CO2 Emissions	194 g/km				

*MSRP (MS) includes VAT and delivery. The prices of the data obtained on-line are approximate and may vary. © 2007 Land Rover. All rights reserved. Land Rover is a registered trademark of the Land Rover Group. Land Rover is a registered trademark of the Land Rover Group. Land Rover is a registered trademark of the Land Rover Group.

OFFSET

AT LEAST 150MM OFFSET MILES LEFT

TRIED, TESTED, APPROVED



snapframes

ONE-YEAR WARRANTY

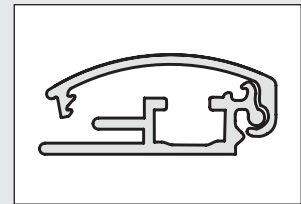

25mm profile with mitred corners.

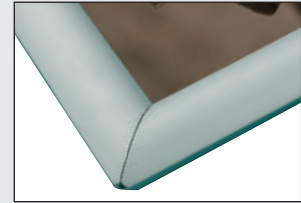

Satin anodised finish.



Frame snaps open with ease.

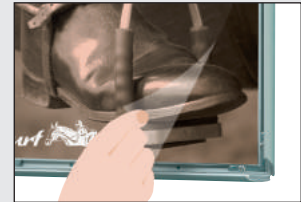

Remove protective acetate sheet.



Insert graphic or poster and snap shut.

CODE	DESCRIPTION
91720	A0 25mm profile snapframe
91721	A1 25mm profile snapframe
91722	A2 25mm profile snapframe
91723	A3 25mm profile snapframe
91724	A4 25mm profile snapframe

features

- Snap opening frames in a satin anodised finish
- Available in 5 sizes – A0, A1, A2, A3 and A4
- Single-sided wall mounted display
- Can be fitted landscape or portrait
- Comes complete with protective front covers
- Wall fixings and screws supplied as standard
- Individually boxed
- Visual area: 8mm around all edges is covered by the snapframe

N.B. For internal use only.



NOTE: Hardware only no graphics included.

GRAPHIC PANEL SIZES

- Finished size:
 - A4 – 297 x 210mm
 - A3 – 420 x 297mm
 - A2 – 594 x 420mm
 - A1 – 841 x 594mm
 - A0 – 1189 x 841mm



Sign holder can rotate from portrait to landscape.

PRODUCT HEIGHTS

- **A4 portrait/landscape:**
Portrait – 1210mm
Landscape – 1170mm
- **A3 portrait/landscape:**
Portrait – 1260mm
Landscape – 1200mm

FOOTPRINT SIZES

- **A4/A3**
325 [w] x 245 [l]mm

GRAPHIC PANEL SIZES

- **Finished size:**
A4 – 297 x 210mm
A3 – 420 x 297mm
- **Visual area:**
10.5mm around all edges is covered by the snapframe mechanism for all sizes



32mm snapframe enables easy graphic change.



Telescopic sign holder can rotate from portrait to landscape.

PRODUCT HEIGHTS

- **A4 telescopic:**
Portrait - 830 to 1210mm
Landscape - 780 to 1160mm
- **A3 telescopic:**
Portrait - 890 to 1250mm
Landscape - 825 to 1185mm

FOOTPRINT SIZES

- **A4/A3**
320mm diameter

GRAPHIC PANEL SIZES

- **Finished size:**
A4 – 297 x 210mm
A3 – 420 x 297mm
- **Visual area:**
A4 – 277 x 190mm
A3 – 400 x 277mm

sign holders



CODE	DESCRIPTION
90625	A4 portrait/landscape sign holders
90626	A3 portrait/landscape sign holders

features

- Snap opening frames in a satin anodised finish
- 25mm snap frame profile
- Comes complete with protective front corners
- Frames rotate from portrait to landscape
- Stylish chrome rounded corners

N.B. For internal use only.

telescopic sign holders



CODE	DESCRIPTION
91781	A4 portrait/landscape telescopic sign holders
90624	A3 portrait/landscape telescopic sign holders

features

- Snap opening frames in a satin anodised finish
- 32mm snap frame profile
- Stylish chrome rounded corners
- A4 extends from 830mm to 1210mm (portrait)
- A3 extends from 890mm to 1250mm (portrait)
- Frames rotate from portrait to landscape
- Chrome base and telescopic pole
- Frame can be tilted to various angles
- Comes complete with protective front corners

N.B. For internal use only.

NOTE: Hardware only no graphics included.

telescopic iPad holder

floor standing

TWO-YEAR WARRANTY

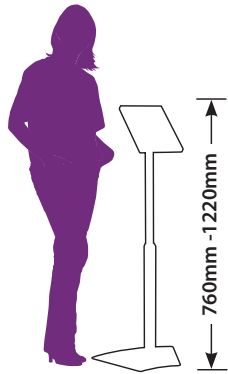

Footprint: 440 [w] x 345 [d]mm



CODE	DESCRIPTION
91813	telescopic iPad holder / black
91850	telescopic iPad holder / white
91957	replacement iPad enclosure / black*
91958	replacement iPad enclosure / white*

features

You Tube Visit www.youtube.com/PlexDisplayLimited for instruction videos.

- Suitable for iPad 2, 3, 4, iPad pro 9.7inch only, Air or Air 2
- Can be used portrait or landscape
- Lockable
- Tilt facility for multiple viewing angles
- Height adjustable 700 - 1100mm
- Cable routing slot on rear of post
- Home button accessible (blanking button provided)
- Holes in base so unit can be secured to floor (fixings supplied)

*N.B. For internal use only. PLEASE NOTE: iPad not included. *Keys are included with the replacement iPad holder head units.*

iPad holder

fixed height

TWO-YEAR WARRANTY

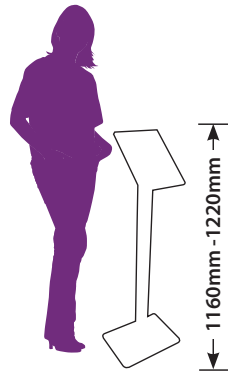

Footprint: 400 [w] x 300 [d]mm



CODE	DESCRIPTION
91955	iPad holder - fixed height / white rotating head
91926	Left hand literature unit / white
91927	Right hand literature unit / white

features

- Suitable for iPad 2, 3, 4, iPad pro 9.7inch only, Air or Air 2
- Can be used portrait or landscape without unscrewing
- Lockable
- Tilt facility for multiple viewing angles
- Cable routing inside post
- Home button accessible (blanking button provided)
- Holes in base so unit can be secured to floor (fixings supplied)
- Add upto 6 A4 portrait literature units

N.B. For internal use only. PLEASE NOTE: iPad not included.

NOTE: Hardware only no graphics included.



Height adjustable.



Holds iPad securely whilst in enclosure.



Lockable enclosure, with home button accessibility.

PRODUCT HEIGHTS

- **Portrait:**
Extends from 800 - 1220mm
- **Landscape:**
Extends from 760 - 1190mm



The head of the unit can be rotated to portrait or landscape.

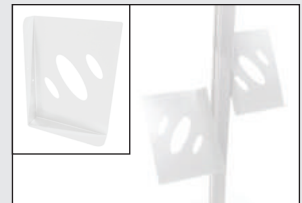

Literature holders can be placed either side and at different heights.

PRODUCT HEIGHT

- **Portrait:**
1220mm
- **Landscape:**
1160mm

FOOTPRINT SIZE

400 [w] x 300 [d]mm

ASSEMBLED WEIGHT

9kg



Mounting bracket allows for the unit to be fixed to a wall or desktop.

iPad holder - wall or desktop



LOCKABLE

PRODUCT HEIGHTS

- **Wall mount**
150 - 266mm
- **Desk mount**
145 - 221mm

ASSEMBLED WEIGHT

1.86kg

CODE	DESCRIPTION
91967	iPad holder white - wall or desktop [†] with black mounting bracket
91968	iPad holder black - wall or desktop [†] with black mounting bracket
91956	iPad holder wall or desktop mounting bracket*
91957	iPad enclosure / black
91958	iPad enclosure / white

features

- Suitable for iPad 2, 3, 4, iPad pro 9.7inch only, Air or Air 2
- Enclosure available in black or white
- Lockable enclosure
- Cable routing slot
- Home button accessible (blanking button included)
- Anti theft wall or desktop mounting bracket available in black. Can be used portrait or landscape.[†]

N.B. For internal use only. [†]Desktop-landscape only. Replacement mount is compatible with both 91957 & 91958.*
PLEASE NOTE: iPad not included.



Easily placed on any desktop surface.

iPad holder - desktop



Holds iPad securely.



PRODUCT HEIGHT

- **Portrait:**
250mm
- **Landscape:**
220mm

FOOTPRINT SIZE

170 x 170mm

ASSEMBLED WEIGHT

0.4kg

CODE	DESCRIPTION
91846	iPad holder - desktop

features

- Suitable for iPad 2, 3 and 4
- Rotates from portrait to landscape
- Tilt facility for multiple viewing angles
- 1 year warranty applies

N.B. For internal use only. PLEASE NOTE: iPad not included.

NOTE: Hardware only no graphics included.

universal tablet holder

floor standing

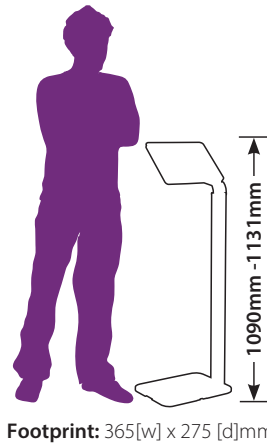

Footprint: 365[w] x 275 [d]mm



LOCKABLE

CODE	DESCRIPTION
91848	Universal tablet holder - floor standing

features

- Suitable for tablets with a minimum size of 220 x 160mm and a maximum size of 245 x 180 x 9mm
- Lockable, robust moulded plastic holder
- Can be used as portrait or landscape
- Cables hide discretely inside post
- Unit can be secured to floor (fixings supplied)
- 2 year warranty applies

N.B. For internal use only. PLEASE NOTE: Tablet not included.

universal tablet holder

desktop



LOCKABLE

CODE	DESCRIPTION
91849	Universal tablet holder desktop

features

- Suitable for iPad 2, 3, 4, iPad pro 9.7inch only, Air or Air 2
- Suitable for tablets with a minimum size of 220 x 160mm and a maximum size of 245 x 180 x 9mm
- Lockable, robust moulded plastic holder
- Can be used as portrait or landscape
- Cables hide discretely inside post
- Unit can be secured to desktop (fixings supplied)

N.B. For internal use only. PLEASE NOTE: Tablet not included.

NOTE: Hardware only no graphics included.

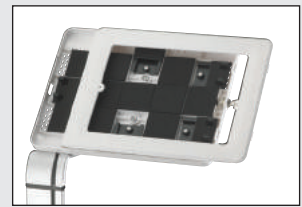

Sliding enclosure holds a tablet with a maximum size of 245 x 180 x 9mm.



Lockable unit, with home button accessibility.

PRODUCT HEIGHTS

1090mm - 1131mm
(Maximum height as portrait)

ASSEMBLED WEIGHT

2.5kg



Easily placed on any desktop surface.

PRODUCT HEIGHTS

- **Portrait:**
Extends from 800 - 1220mm
- **Landscape:**
Extends from 760 - 1190mm



Suitable for desktop.



Can hold a tablet or phone device with a maximum thickness of 10mm.

PRODUCT DIMENSIONS

UNFOLDED

70 [h] x 100 [w] x 90mm [d]

FOLDED

100 [h] x 85 [w] x 23mm [d]

WEIGHT

0.1kg

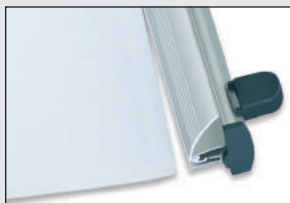

Slide graphic into 'Snapper'.



Snap action mechanism securely holds graphic in place.

GRAPHIC PANEL SIZES

• Finished size:

- A4 – 297 x 210mm
- A3 – 420 x 297mm
- A2 – 594 x 420mm

• Visual area:

14mm at the top and bottom is hidden by the poster snapper for all sizes

universal folding tablet stand



CODE	DESCRIPTION
91847	Universal folding tablet stand

features

- Suitable for tablets and phones with a maximum thickness of 10mm
- Adjustable stand for multiple viewing angles
- 1 year warranty applies

poster snapper



3 SIZES AVAILABLE:

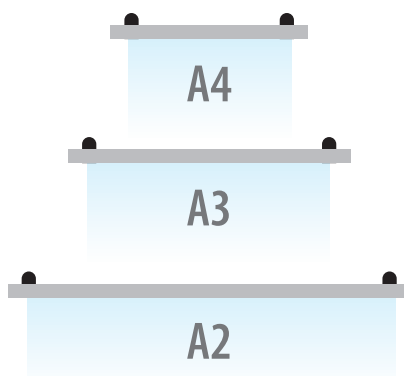

CODE	DESCRIPTION
40152	210mm wide poster snapper [A4 portrait]
40153	297mm wide poster snapper [A4 landscape/A3 portrait]
40155	420mm wide poster snapper [A3 landscape/A2 portrait]

features

- Snap opening poster holder in a satin anodised finish
- Available in 3 sizes – A2, A3, A4
- Plastic moulded end caps
- Holds material to a thickness of 500 microns

*N.B. For internal use only. *Wire not included.*

NOTE: Hardware only no graphics included.



Elgars
Baguettes
Jacket Potatoes
Light Lunches
Open Sandwiches
Cakes
Beverages
Club Sandwiches

Elgars
Chicken Bacon Caesar Salad £8.00
Pheasant's Brunch £10.00
Honey Mustard Salad £8.00
Potato Skins £4.50
Pear, Shilton Walnut Salad £8.00
Chicken and Pineapple £8.00
Homemade Chicken Liver Pate £6.00
Brioche Salad £8.00
Coffee Shop & Licensed Restaurant
15-17 St. James Street

ELGARS
REINDEER COURT
COFFEE SHOP & RESTAURANT



cafébarriers

QUICK REFERENCE GUIDE



primo slide

PRODUCT SELECTOR

PRICE INDICATOR



GRAPHIC ATTACHMENT METHOD

Top cross arm = mechanical slide-in hanger
Bottom cross arm = mechanical slide-in hanger

WEIGHT OF POST

17kg

CROSS ARM WIDTH OPTIONS*

2000mm / 1500mm / 1200mm

PAGE 52



primo wrap



Top cross arm = looped graphic
Bottom cross arm = looped graphic

17kg

2000mm / 1500mm / 1200mm

PAGE 53



medio slide



Top cross arm = mechanical slide-in hanger
Bottom cross arm = eyelet and spring clip

10.5kg or 16kg

2000mm / 1500mm / 1200mm

PAGE 54



medio wrap

PRODUCT SELECTOR

PRICE INDICATOR



GRAPHIC ATTACHMENT METHOD

Top cross arm = looped graphic
Bottom cross arm = eyelet and spring clip

WEIGHT OF POST

10.5kg or 16kg

CROSS ARM WIDTH OPTIONS*

2000mm / 1500mm / 1200mm

PAGE 55



espresso



Top cross arm = looped graphic
Bottom cross arm = eyelet and spring clip

12.5kg

2000mm / 1500mm / 1200mm

PAGE 56

* Width is calculated from centre of post to centre of post [see footprint detail on page 57].

primo slide



CODE	DESCRIPTION
91368	Primo café barrier post and base single unit top and bottom
91940	1200mm Primo slide snapfit café barrier top and bottom cross arm set*
91941	1500mm Primo slide snapfit café barrier top and bottom cross arm set*
91942	2000mm Primo slide snapfit café barrier top and bottom cross arm set*
91527	Primo café barrier wall fixing bracket top and bottom set

*see page 57 for system and graphic dimensions.



features

- Slide graphics into the cross arms
- 17kg Primo post with stainless steel base cover
- Primo Slide cross arms eliminate the need to stitch or eyelet graphics
- Three cross arm width options – 2000mm, 1500mm and 1200mm
- Polished chrome finish
- Strong, durable snapfit cross arms and posts
- Wall mounting bracket available
- Posts complete with child friendly hole blanks

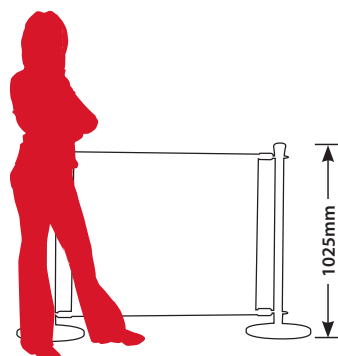

NOTE: Hardware only no graphics included.

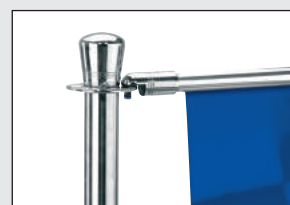

Robust snap fit cross arms onto post.



Unique graphic attachment eliminates the need to stitch or eyelet graphics.



Wall mounted fixing bracket.



Child friendly hole blanks.
(Medio example shown)

GRAPHIC PANEL SIZES

- **Finished size:**
830 x 975/1275/1775mm
- **Visual area:**
800 x 975/1275/1775mm
[15mm at the top and bottom are hidden by the hanger]



Fabric graphic looped over snap fit cross arm.



Polished stainless steel base.



Wall mounted fixing bracket.



Child friendly hole blanks.
(Medio example shown)

GRAPHIC PANEL SIZES

- **Finished size:**
1100 x 975/1275/1775mm
- **Visual area:**
900 x 975/1275/1775mm
[100mm bleed at the top and the bottom for the loops]

primo wrap



CODE	DESCRIPTION
91368	Primo café barrier post and base single unit top and bottom
91905	1200mm Primo wrap snapfit café barrier top and bottom cross arm set*
91906	1500mm Primo wrap snapfit café barrier top and bottom cross arm set*
91907	2000mm Primo wrap snapfit café barrier top and bottom cross arm set*
91527	Primo café barrier wall fixing bracket top and bottom set

*see page 57 for system and graphic dimensions.



features

- Loop the graphics over the top and bottom cross arms
- 17kg Primo post with stainless steel base cover
- Three cross arm width options – 2000mm, 1500mm and 1200mm
- Powder coated cross arms with chrome ends
- Strong, durable snapfit cross arms and posts
- Polished chrome finish on visible parts
- Wall mounting bracket available
- Posts complete with child friendly hole blanks

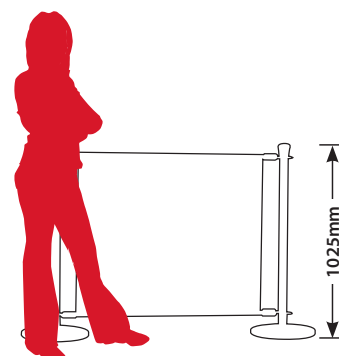

NOTE: Hardware only no graphics included.

medio slide



Robust fixings secure cross arms onto post.



Unique graphic attachment eliminates the need to stitch graphics.



Wall mounted fixing bracket.



Child friendly hole blanks. (Medio example shown)

CODE	DESCRIPTION
91567	Medio café barrier post and base single unit 10.5kg
91990	Medio café barrier post and heavy base 16kg
91604	1200mm Medio slide café barrier cross arm and spring fittings*
91603	1500mm Medio slide café barrier cross arm and spring fittings*
91602	2000mm Medio slide café barrier cross arm and spring fittings*
91605	Medio café barrier wall mounted bracket [pair]
91568	Medio café barrier spring clip [pair]
91122	Bungee ties white with black stripes (PK10)

*see page 57 for system and graphic dimensions.

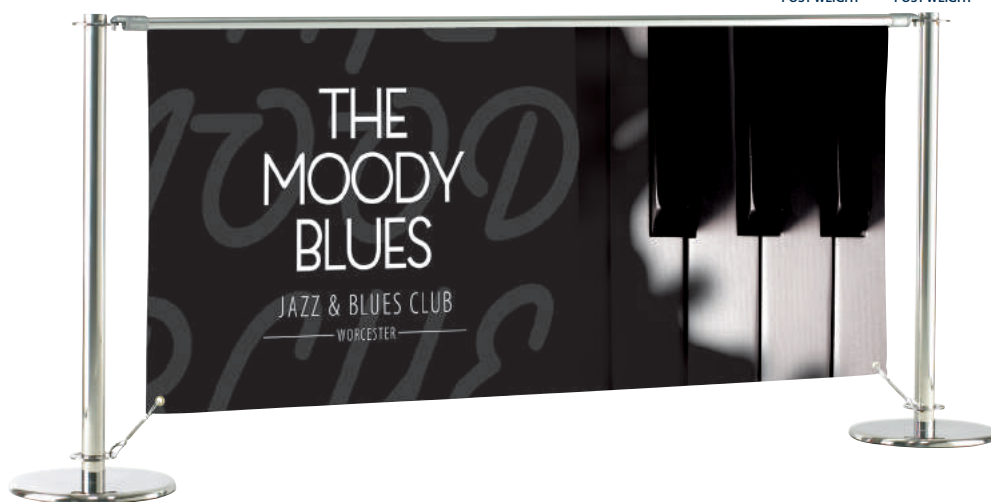

GRAPHIC PANEL SIZES

- **Finished size:**
835 x 975/1275/1775mm
- **Visual area:**
820 x 975/1275/1775mm
[top 15mm is hidden by the hanger]

features

- Slide graphics into the top cross arm
- 10.5kg or 16kg polished stainless steel Medio post and base
- Medio Slide cross arms and spring clips eliminate the need to stitch graphics
- Three cross arm width options – 2000mm, 1500mm and 1200mm
- Polished chrome finish cross arms
- Strong, durable cross arm
- Wall mounting bracket available
- Posts complete with child friendly hole blanks

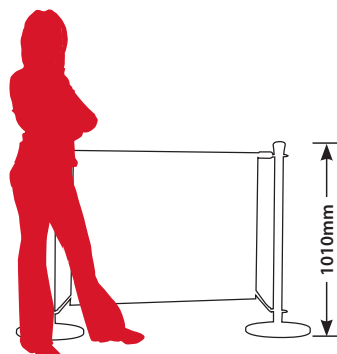

NOTE: Hardware only no graphics included.



Fabric graphic looped over cross arm.



Bottom of graphic attaches using a spring clip.



Wall mounted fixing bracket.



Child friendly hole blanks.
(Medio example shown)

GRAPHIC PANEL SIZES

- **Finished size:**
950 x 975/1275/1775mm
- **Visual area:**
850 x 975/1275/1775mm
[100mm bleed at the top for the loop]

medio wrap



CODE	DESCRIPTION
91567	Medio café barrier post and base single unit 10.5kg
91990	Medio café barrier post and heavy base 16kg
91741	1200mm Medio wrap café barrier cross arm and spring fittings*
91742	1500mm Medio wrap café barrier cross arm and spring fittings*
91743	2000mm Medio wrap café barrier cross arm and spring fittings*
91605	Medio café barrier wall mounted bracket [pair]
91568	Medio café barrier spring clip [pair]
91122	Bungee ties white with black stripes (PK10)

*see page 57 for system and graphic dimensions.



features

- Loop graphics over the top cross arm
- 10.5kg or 16kg polished stainless steel Medio post and base options
- Three cross arm width options – 2000mm, 1500mm and 1200mm
- Powder coated cross arm with polished chrome ends
- Strong, durable cross arm
- Wall mounting bracket available
- Posts complete with child friendly hole blanks

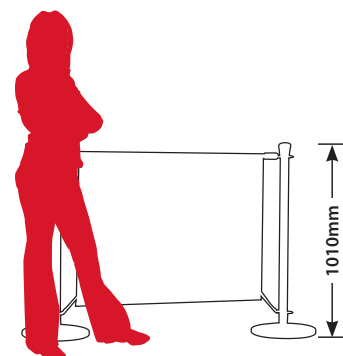

NOTE: Hardware only no graphics included.



Robust fixings secure cross arms onto post.



Bottom of graphic attaches using a spring clip.



Wall mounted fixing bracket.



Child friendly hole blanks. (Medio example shown)

CODE	DESCRIPTION
91663	Espresso café barrier post and base single unit
91563	1200mm Espresso café barrier cross arm and spring fittings*
91564	1500mm Espresso café banner cross arm and spring fittings*
91565	2000mm Espresso café banner cross arm and spring fittings*
91606	Espresso café banner wall mounted bracket [pair]
91566	Espresso café banner spring clip [pair]
91122	Bungee ties white with black stripes (PK10)

*see page 57 for system and graphic dimensions.



features

- Loop graphics over the top cross arm
- Black powder coated post and base - 12.5kg
- Bottom of graphic attaches to post using a spring clip
- Three cross arm width options – 2000mm, 1500mm and 1200mm
- Strong, durable cross arm
- Wall mounting bracket available
- Post complete with child friendly hole blanks

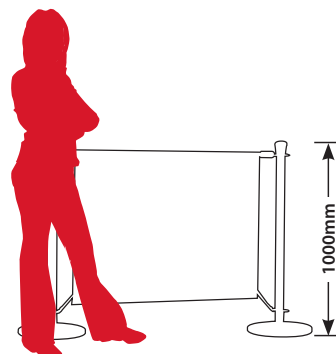

GRAPHIC PANEL SIZES

- **Finished size:**
900 x 975/1275/1775mm
- **Visual area:**
800 x 975/1275/1775mm
[100mm bleed at the top for the loop]

NOTE: Hardware only no graphics included.

café barrier footprints and dimensions

footprints

Primo Slide/ Primo Wrap

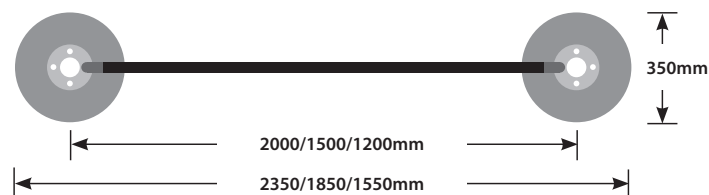

Medio Slide/ Medio Wrap

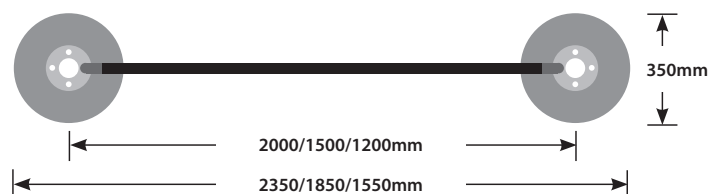

Espresso

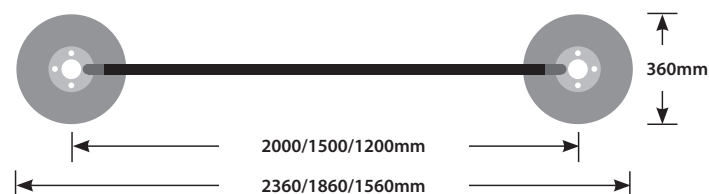

assembled dimensions

	PRIMO SLIDE & WRAP		MEDIO STANDARD SLIDE & WRAP		MEDIO HEAVY BASE SLIDE & WRAP		ESPRESSO
Base diameter	350mm	350mm	350mm	350mm	350mm	350mm	360mm
Post height	1025mm	1025mm	1010mm	1010mm	1020mm	1020mm	1000mm
Height of base	35mm	35mm	25mm	25mm	35mm	35mm	75mm
Height to underside of bottom bar	100mm	100mm	N/A	N/A	N/A	N/A	N/A
Height to bottom edge of graphic	N/A	N/A	145mm	145mm	155mm	155mm	200mm
Post diameter	50mm	50mm	50.4mm	50.4mm	50.4mm	50.4mm	51mm

graphic panel sizes

Primo Slide

Overall graphic area

- 975/1275/1775 [w] x 830 [h]mm

Visual graphic area

- 975/1275/1775 [w] x 800 [h]mm

Medio Slide

Overall graphic area

- 975/1275/1775 [w] x 835 [h]mm

Visual graphic area

- 975/1275/1775 [w] x 820 [h]mm

Primo Wrap

Overall graphic area

- 975/1275/1775 [w] x 1100 [h]mm

Visual graphic area

- 975/1275/1775 [w] x 900 [h]mm

Medio Wrap

Overall graphic area

- 975/1275/1775 [w] x 950 [h]mm

Visual graphic area

- 975/1275/1775 [w] x 850 [h]mm

Espresso

Overall graphic area

- 975/1275/1775 [w] x 900 [h]mm

Visual graphic area

- 975/1275/1775 [w] x 800 [h]mm

NOTE: Hardware only no graphics included.

pedestrian guidance systems

QUICK REFERENCE GUIDE



queue management

PRODUCT SELECTOR

PRICE INDICATOR



GRAPHIC ATTACHMENT METHOD

N/A

WEIGHT OF POST

7kg

CROSS ARM WIDTH OPTIONS*

2m belt

PAGE 59

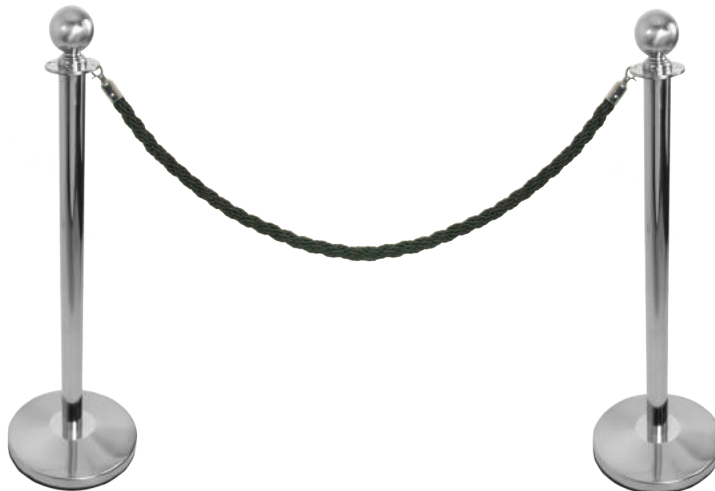

rope barriers

PRODUCT SELECTOR

PRICE INDICATOR



GRAPHIC ATTACHMENT METHOD

N/A

WEIGHT OF POST

7.5kg or 8.2kg

CROSS ARM WIDTH OPTIONS*

1.5m rope

PAGE 60

queue management



Polished stainless steel.



Add advertising space to your Q management. A4 portrait signholder.



Belt cartridges now available in red and blue as well as black.



Stainless steel wall receiving bracket.



Wall mounted cartridge available in black only.

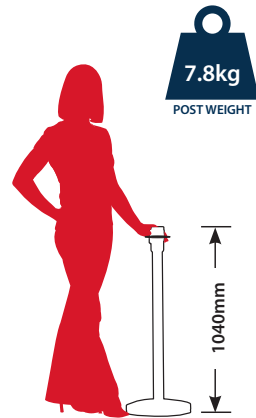

Footprint: 320mm diameter



CODE	DESCRIPTION
91980	Queue management black belt single post kit
91981	Queue management red belt single post kit
91982	Queue management blue belt single post kit
91331	Queue management black belt wall mounted cartridge
91332	Queue management wall mounted receiving bracket
91974	Queue management push fit A4 portrait signholder

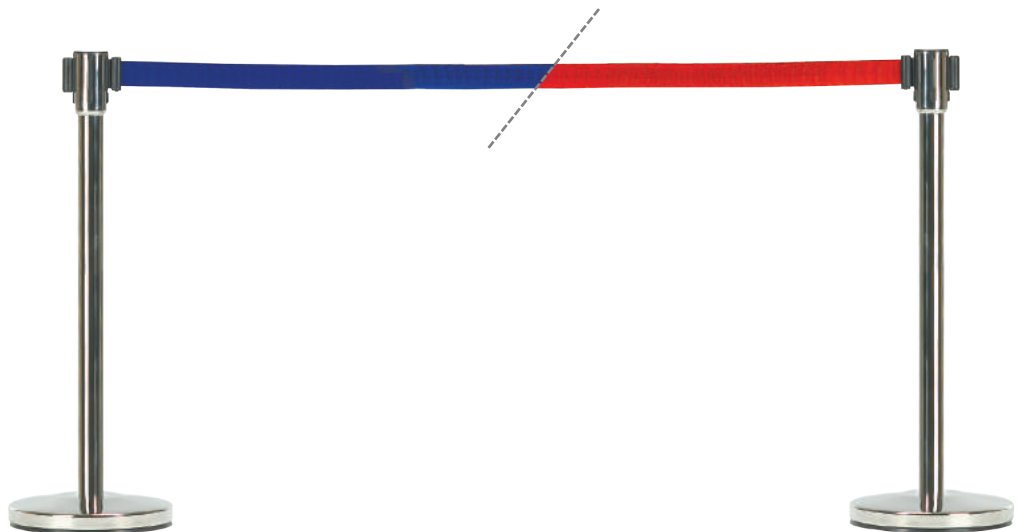

features

- Pedestrian guidance system
- Polished stainless steel
- 2000mm retractable black, red and blue webbing belt
- 4 way connectivity on each post
- Tamper proof locking mechanism
- 1040mm post and base overall height – 7.8kg
- Interchangeable belt cartridges
- Screwfit assembly
- A4 portrait pushfit signholder option

N.B. Recommended for internal use only.

NOTE: Hardware only no graphics included.

rope barriers

ONE-YEAR WARRANTY

ball top

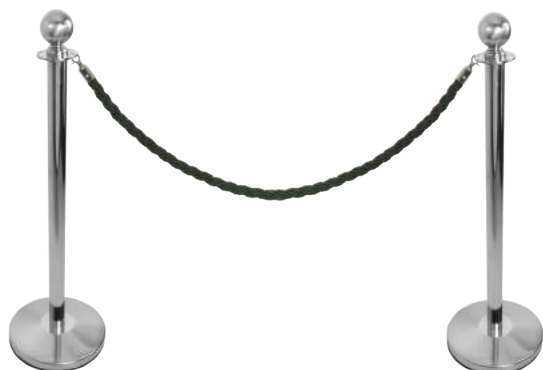

7.5kg
POST WEIGHT

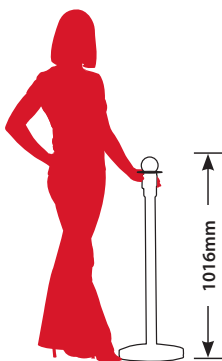

Footprint: 320mm diameter



Post with 80mm diameter ball top.



Post with 25mm high flat top.



Post with frame top. Graphic slides in from top between 2x acrylic sheets. Double sided.

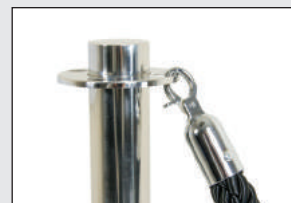

Spring action chromed end clips.

flat top



7.5kg
POST WEIGHT

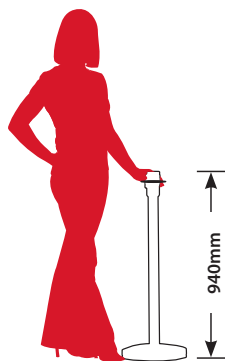

Footprint: 320mm diameter

sign holder top



8.2kg
POST WEIGHT

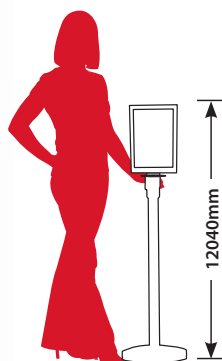

Footprint: 320mm diameter

ropes



CODE	DESCRIPTION
91985	Rope barrier post and base 80mm ball top
91986	Rope barrier post and base 25mm flat top
91987	Rope barrier post and base A4 portrait sign holder
91977	Screw in sign holder A4 portrait only for post top*
91867	Black rope barrier 1500mm
91868	Red rope barrier 1500mm
91869	Blue rope barrier 1500mm

*Please note: Sign holder replaces ball or flat top.

features

- Stainless steel base, post and tops
- Screwfit assembly
- 28mm diameter twisted rope
- Rope consists of Terylene outer with a cotton core
- Spring action chromed end clips
- Black, Red and Blue colours available
- Compatible with our cafe barrier range

NOTE: Hardware only no graphics included.

PRODUCT DIMENSIONS

- **Rope length:** 1.5m length [overall length including end clips 1530mm]



Zinc Plated Steel Frame

Heavy duty 1 inch x 1 inch (25mm x 25mm) steel box section tube with a 2mm wall thickness and is supplied with a high quality Zinc Plated rust resistant finish to ensure it continues to look great even after extensive use.



Fitted PVC Tarpaulins

The Tansley Elite is supplied with premium grade 550gsm PVC roof canopy, available in Red, Green, Yellow, White, Blue and Black or striped.



Counter Boards

The counter boards supplied with this Market Stall are manufactured from a 9mm exterior grade plywood. They are split into three 3ft x 2ft sections which lay flat on top of the market stall framework to form an overall 6ft x 3ft (1.8m x 0.9m) front counter space.

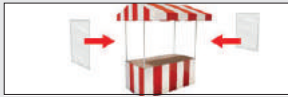

Clear Upper Sidewalls

Optional extra - clear upper sidewalls can also be purchased as part of the kit or separately. Side walls are manufactured from a heavy duty 350gsm glass clear PVC material to enable maximum light penetration whilst offering full protection from the elements.



Carry Bag

Optional extra - robust wheeled carry bags have been developed here in the UK specifically for carrying our market stall frames. They are manufactured from a 550gsm heavy duty PVC material with re-enforced ends and are supplied with heavy duty zips and rubberised handles at each end to reduce abrasion on your hands during transportation.



Bespoke Canopy Printing and Branding Service

Whether is a simple text print or a full colour digital print we have solutions to suit all budgets

tansley elite market stall



CODE	DESCRIPTION
MS-TANSELI-6x3	Tansley Elite Market Stall Kit

FRONT

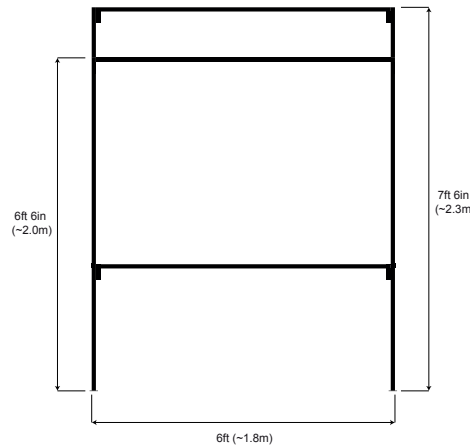

SIDE

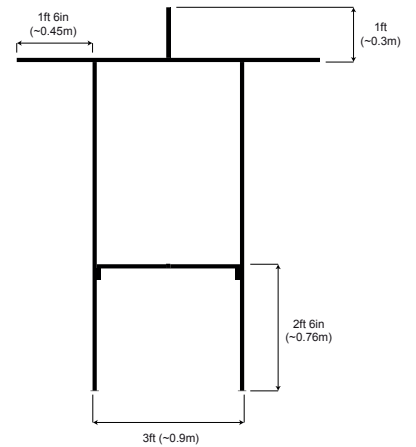

TOP

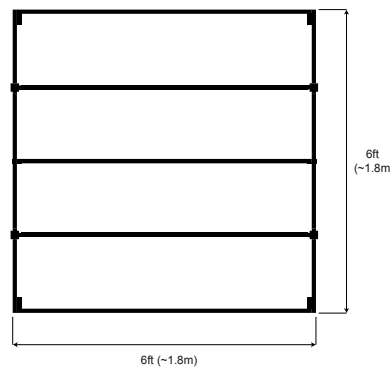

ASSEMBLY

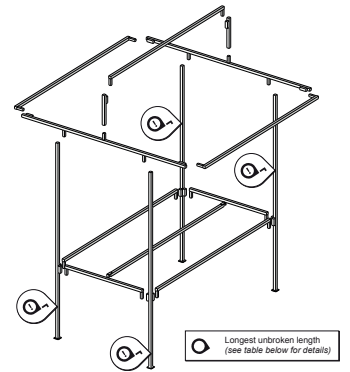

features

- Premium Silver Zinc Plated Steel Market Stall Frame
- Premium Grade 550gsm PVC Roof and Counter Skirt Tarpaulins
- 9mm exterior grade plywood counter boards
- Clear upper side walls (optional extra)
- Wheeled carry bag (optional extra)
- Instruction manual

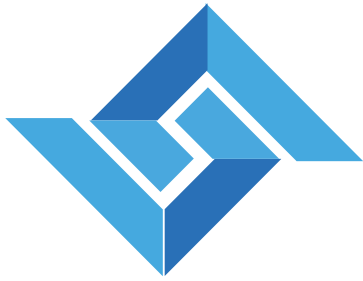

Somnium Signs Ltd



**Display, Signage, Café Barriers
& Pedestrian Guidance Systems**

**For further information please call: 01352 375908
or Email: info@somniumsigns.co.uk**