

We produce  
satisfaction.

1

### **Developing ideas**

You want to build the best machine possible and already have some initial ideas? Then get these down on paper together with us, starting with small, yet detailed innovative steps and going all the way to completely new machines.

Working together, we will develop an intelligent and sustainable concept that is perfectly aligned with your specific requirements.

2

### **Drafting concepts**

We see welcome challenges in your machine tasks, supporting you with our comprehensive expertise and providing valuable impetus for your innovations. We take a holistic view of the individual motion and control functions here and draw up consistent, end-to-end drive and automation solutions for you - keeping everything as easy as possible and as extensive as necessary.

# Lenze makes many things easy for you.

With our motivated and committed approach, we work together with you to create the best possible solution and set your ideas in motion - whether you are looking to optimise an existing machine or develop a new one. We always strive to make things easy and seek perfection therein. This is anchored in our thinking, in our services and in every detail of our products. It's as easy as that!

3

## Implementing solutions

Our easy formula for satisfied customers is to establish an active partnership with fast decision-making processes and an individually tailored offer. We have been using this simple principle to meet the ever more specialised customer requirements in the field of mechanical engineering for many years.

4

## Manufacturing machines

Functional diversity in perfect harmony: as one of the few full-range providers in the market, we can provide you with precisely those products that you actually need for any machine task – no more and no less. Our L-force product portfolio, a consistent platform for implementing drive and automation tasks, is invaluable in this regard.





5

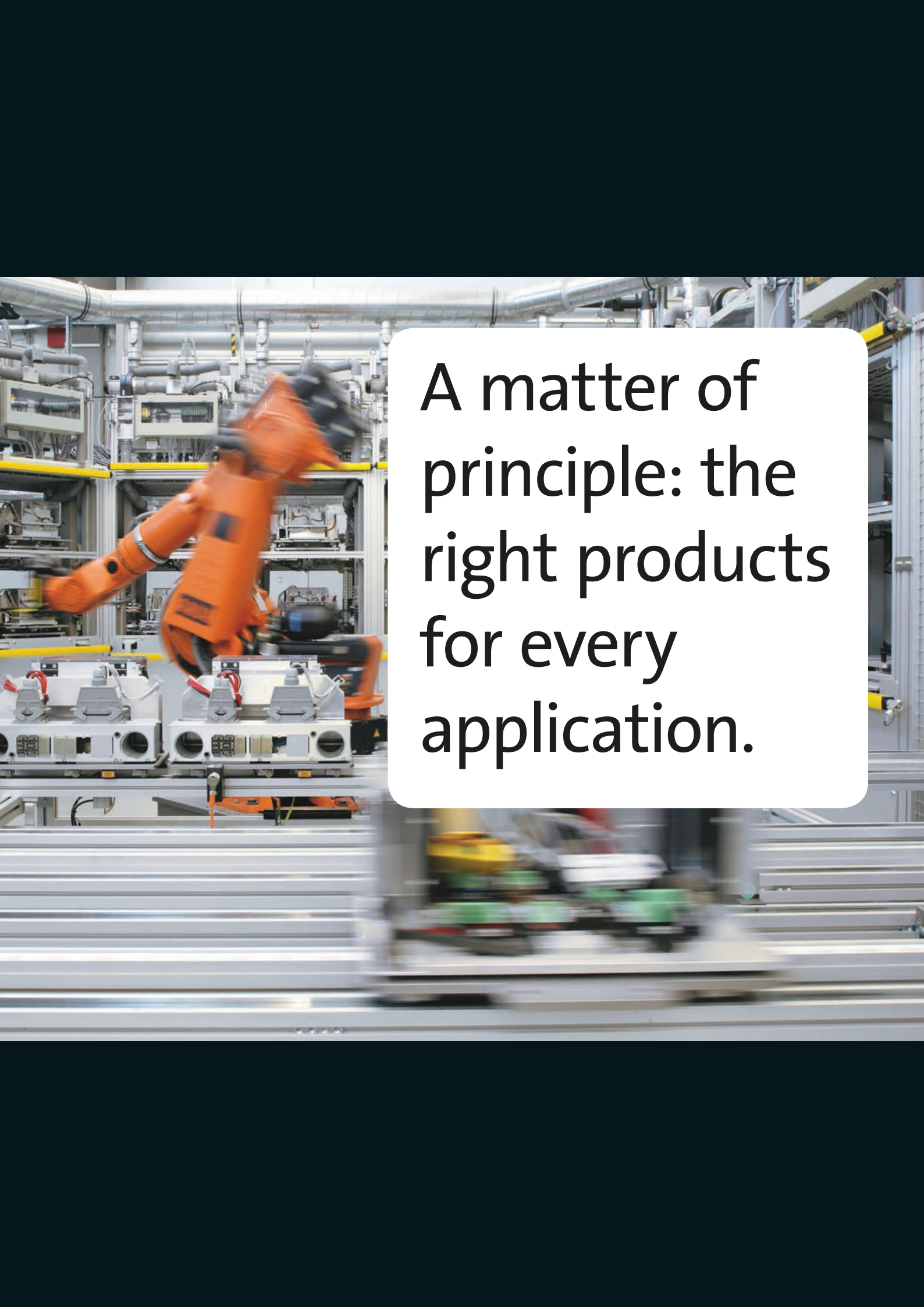



## Ensuring productivity

Productivity, reliability and new performance peaks on a daily basis – these are our key success factors for your machine. After delivery, we offer you cleverly devised service concepts to ensure continued safe operation. The primary focus here is on technical support, based on the excellent application expertise of our highly skilled and knowledgeable aftersales team.

A photograph of an industrial robotic arm in a factory. The arm is orange and is positioned over a workbench with various mechanical components. The background shows a complex industrial environment with pipes, machinery, and a blurred foreground suggesting motion. The text is overlaid on a white rounded rectangle in the center-right of the image.

A matter of principle: the right products for every application.

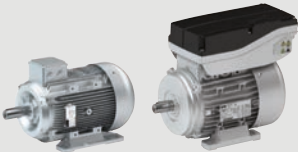
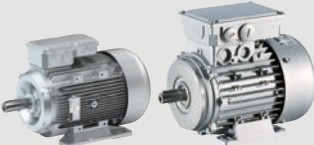
Controlling and visualising events	Automating and visualising machine modules	Automating and visualising machines
<p>Logic control</p> <p>Visualisation</p>	<p>Machine module-control</p> 	<p>Machine control</p> 
<p>Controllers</p> 	<p>Machine module-control</p> 	

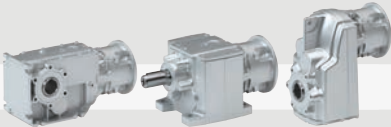
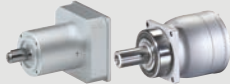
Time and event-controlled motion	Speed and torque-controlled motion	Position-controlled single-axis and multi-axis motion
<p>Mains operation</p>	<p>Inverter operation</p>	<p>Servo inverter operation</p>
<p>Inverter</p>		
<p>Motors</p> 		
<p>Gearbox</p>		

Controlling  
made easy  
in any  
situation.

From event-controlled controlling to full machine automation, our portfolio of visualisation and controlling components offers all the right products for modern system solutions.

Perfectly adapted to downstream drive solutions, they are the embodiment of Lenze's extensive machine know-how and its benefits.

But what does this mean for you? It allows you to quickly recognise which products represent the best solution for your own specific requirements.

**The results are clear:**

- Coordinated interfaces
- Optimised runtimes
- Compact engineering

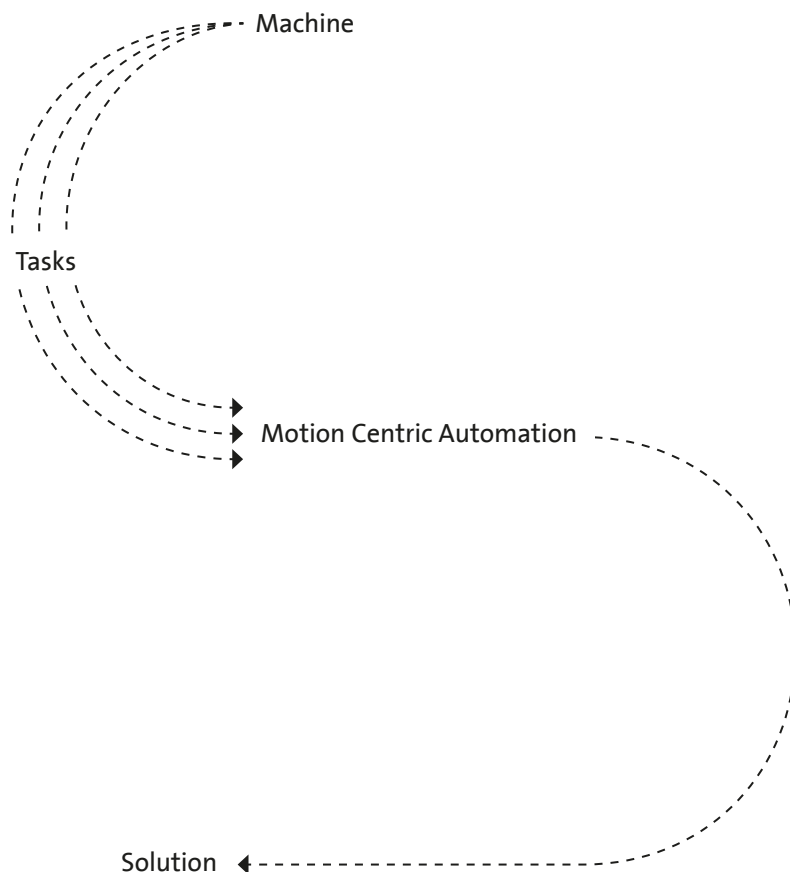

# Faster switching, better response.





The full benefit of the Lenze L-force product portfolio can be exploited using our controls, providing you with powerful automation products. From modern visualisation with panel PCs or monitors through to powerful panels and cabinet controllers – you are sure to find the right solution for your application here.

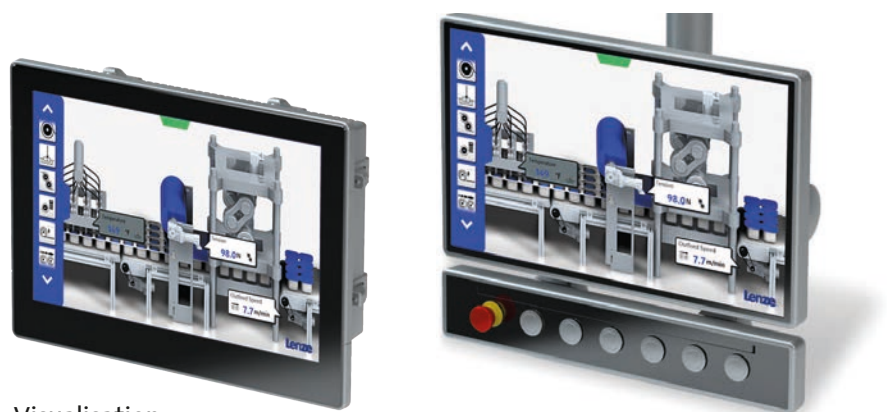

Visualisation







Panel and Cabinet Controllers

## Visualisation

	v200-P		v800-C			v800-P	
<b>Screen diagonal</b>	43.9 cm (17.3")	61 cm (24")	33.8 cm (13.3")	39.1 cm (15.4")	54.6 cm (21.5")	43,9 cm (17,3")	61 cm (24")
<b>Resolution</b>	1920 x 1080		1280 x 800	1280 x 800	1920 x 1080	1920 x 1080	
<b>Touch</b>	Capacitive glass surface, multitouch						
<b>Processor type</b>	Intel® Celeron 1.5 GHz or Intel® Core i5 2.7 GHz						
<b>Graphics processor</b>	Intel® HD Graphics or Intel® HD Graphics 4600						
<b>Interfaces</b>							
COM (RS232)			1				
USB 3.0 / 2.0	-/3		2/2 on rear			2/1	
Ethernet (10/100/1000 Mbit/s)			3			2	
HDMI / Display port	1/1						
<b>Enclosure</b>							
front/rear	IP65/IP20						
On all sides	IP65					IP65	

## Panel and Cabinet Controllers

	c300	p300			3200 C	p500		
								
<b>Screen diagonal</b>		10.9 cm (4.3")	17.8 cm (7")	26.4 cm (10.4")		17.8 cm (7")	26.4 cm (10.4")	38.1 cm (15")
<b>Processor type</b>	ARM Cortex A8 800 MHz	ARM Cortex A8 800 MHz			Intel® Atom™ 1.46 GHz Intel® Atom™ 1.75 GHz Intel® Atom™ 1.91 GHz	Intel® Atom™ 1.75 GHz		
<b>No cooling fan</b>								
<b>Application Credit</b>	Licence to use Lenze FAST							
<b>Memory</b>								
SD card	512 MB	512 MB			≥512 MB	≥512 MB		
RAM	512 MB	512 MB			2 GB	2 GB		
Flash memory	2 GB	2 GB			4 GB	4 GB		
<b>Interfaces</b>								
Ethernet	1	1			2	2		
EtherCAT	1	1			1	1		
CAN	1	1						
USB	1	1			3	2		
Resolution (pixels)		480 x 272	800 x 480	800 x 600		800 x 480	800 x 600	1024 x 768
<b>Option</b>	PROFINET Device	PROFINET Device			CANopen PROFIBUS Slave PROFINET Device EtherNet/IP-Adapter RS232/RS485	CANopen EtherNet/IP-Adapter PROFIBUS Slave PROFINET Device RS232/RS485		
<b>Touch</b>		Resistive				Resistive		
<b>Retain memory size</b>	128 kB	128 kB			60 kB	1,024 kB	1,024 kB	

Three lines  
for greater  
freedom.

Quite simply: You can use our three lines to help you select suitable products based on your requirements. BaseLine is for time and event-controlled movements, State-Line is for speed and torque-controlled movements and HighLine is for position-controlled single and multi-axis movements. This makes it easier for you to select the products you need. This leaves you free to concentrate fully on your core tasks – we'll take care of everything else.

But what does this mean for you? It allows you to quickly recognise which products represent the best solution for your own specific requirements.

**Powerful products with a major impact:**

- easy handling
- high quality and durability
- reliable technologies in tune with the latest developments

Lenze products are subjected to strict and thorough tests in our dedicated test laboratory. This allows us to guarantee you consistent quality and a long service life. In addition to this, our five logistics centres ensure global availability and fast delivery of the Lenze products you select. It's that easy!

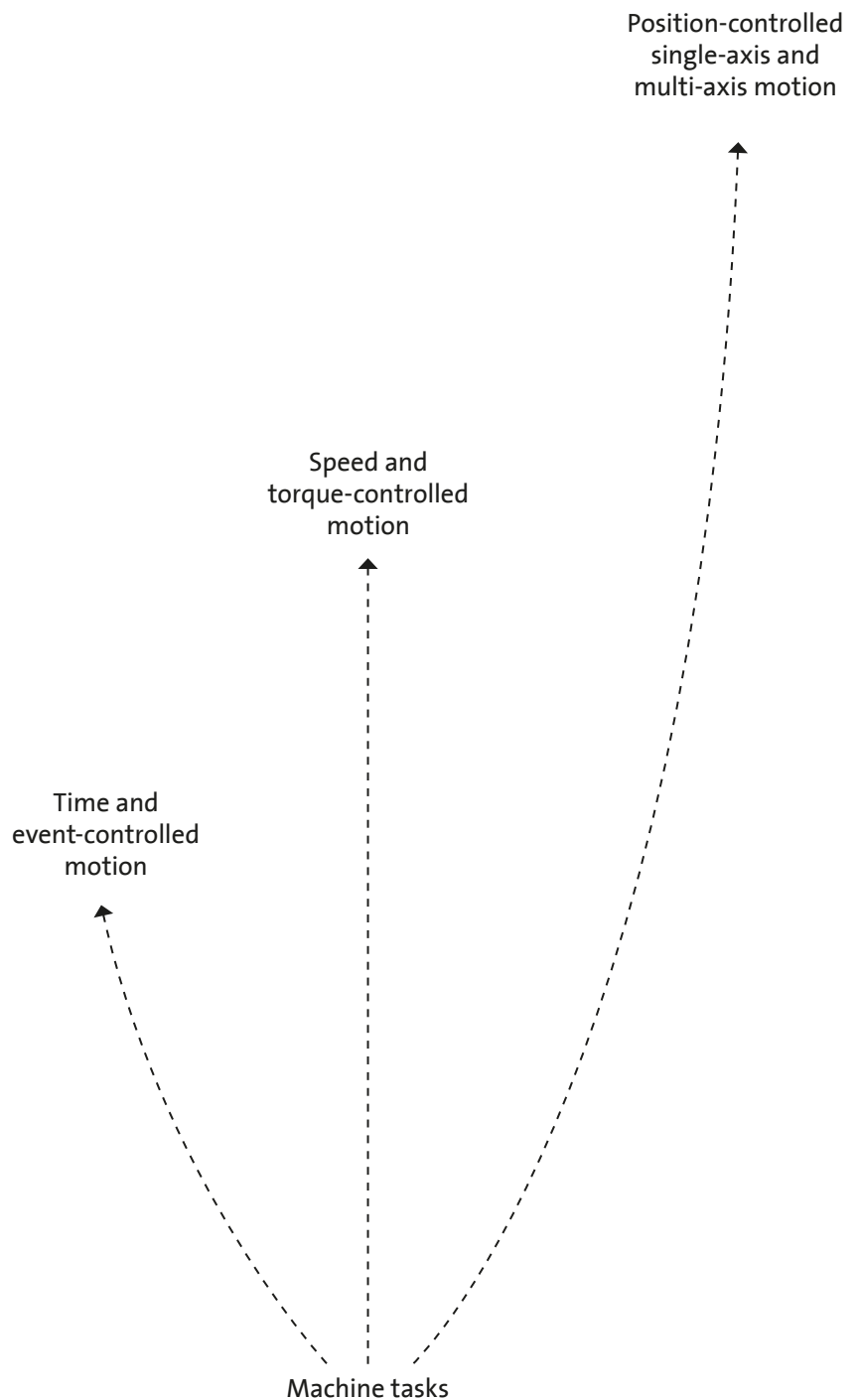

# Inverters: simply indispensable.



In many applications, modern inverters are the key component of a cleverly designed solution. They are true masters when it comes to open and closed-loop control of motors. Lenze's inverters are scalable and always offer you the right solution for speed and torque-controlled motion and for position-controlled single axis and multi-axis motion, perfectly tailored to your own specific requirements.



Cabinet inverters





Decentralised inverters



Cabinet servo inverters



## Cabinet inverters



## Cabinet servo inverters

	i500 inverters 	Inverter Drives 8400 HighLine 	i700 servo inverters 
<b>Power range</b>			
Single phase	0.25 to 2.2 kW	0.25 to 2.2 kW	
3-phase	0.37 to 132 kW	0.37 to 45 kW	0.75 to 15 kW
<b>Output current</b>			
Single phase	1.7 to 9.5 A	1.7 to 9.5 A	
3-phase	1.3 to 254 A	1.3 to 89 A	2.5 to 32 A
<b>Voltage range</b>			
Single phase	170 to 264 V	180 to 264 V	
3-phase	340 to 528 V	320 to 550 V	230 to 480 V
<b>Approvals</b>	CE, UL, CSA, EAC, RoHS, IE2 in accordance with EN50598-2	CE, UL, CSA, EAC, RoHS	CE, UL, cUL, RoHS
<b>Enclosure</b>	IP20	IP20	IP20
<b>Types of motor control</b>			
V/f control	●	●	●
Vector control (encoderless)	●	●	●
Vector control (with encoder)	●	●	●
VFC eco	●	●	
<b>Inputs/outputs</b>			
Analogue input/output	● (2/1)	● (2/2)	
Digital input/output	● (5/1)	● (3)	● (2/0)
Relay output	●	●	
Speed feedback		● (HTL)	● (1)
Encoder output	●	●	
PTC and/or KTY	● (PTC)	● (PTC)	●
<b>Fieldbuses</b>			
AS-Interface			
CAN bus	□	●	
DeviceNet			
EtherCAT	□	□	●
Ethernet Powerlink		□	
Ethernet TCP/IP	□	□	
INTERBUS		□	
LECOM			
Modbus (RTU/RS485)	□		
PROFIBUS	□	□	
PROFINET	□	□	
<b>Safety engineering</b>			
Safe torque off (STO)	□	□	●
Scalable safety functions			▲ (in preparation)
<b>Ideally suited to</b>	Transverse loaders or palletizers in the field of intralogistics, extruders in the plastics industry, filling systems in the packaging industry.	Rotary indexing tables or warehouse systems in the field of intralogistics, bag form, fill, and seal machines in the packaging sector, rolling and sliding door drives.	Coordinated multi-axis applications such as loading drives or gantry systems in the field of robotics, filling systems in the packaging industry.



## Decentralised inverters

i900 servo inverters	Inverter Drives 8400 TopLine	Servo Drives 9400 HighLine
		
	0.55 to 2.2 kW	
0.55 to 110 kW	0.37 to 45 kW	0.37 to 240 kW
	3.0 to 9.5 A	
1.8 to 212 A	1.3 to 89 A	1.9 to 460 A
	180 to 264 V	
340 to 528 V	320 to 550 V	180 to 550 V
CE, UL, cUL, RoHS	CE, UL, cUL, GOST, RoHS	CE, cUL, RoHS
IP20	IP20	IP20
•	•	•
	•	•
•	•	•
	•	
• (1/0)	• (2/2)	• (2/2)
• (4/1)	• (8/4)	• (8/4)
	•	• (1)
• (1)	•	• (3)
	•	□
•	•	•
	•	•
▲ (in preparation)	□	□
	□	□
	□	□
•	□	□
•	□	
•		□
Coordinated multi-axis applications such as loading drives or gantry systems in the field of robotics, filling systems in the packaging industry.	Flying saws and cam discs in the packaging sector, synchronised drives in the printing sector.	Processing continuous material in the packaging industry, perforating paper webs in the printing industry, winding in the textile industry, warehouse technology in the field of intralogistics.

Inverter Drives 8400 motec	Inverter Drives 8400 protec
	
0.37 to 7.5 kW	0.75 to 7.5 kW
1.3 to 16.5 A	2.4 to 16 A
320 to 528 V	320 to 550 V
CE, EAC, UR, cUR, ROHS	CE, EAC, UL, cUL, ROHS
IP65	IP65
•	•
•	•
•	•
□ (1/0)	• (1/0)
• (6/1)	• (4/2 or 6/0)
□ (1)	
• (HTL)	• (HTL)
• (PTC)	• (PTC)
□	
□	▲
□	
□	
□	▲
□	▲
□	
□	□
Travelling drives in the field of intralogistics, fan drives in the air-conditioning sector, pumps in the field of sewage technology.	Scissor-type lift tables in the field of intralogistics and in the automotive industry.



One thing is certain: you need to be able to rely on your motors. They convert electrical energy into mechanical energy and are therefore the central drive component in your machine. Since they play such an important part, we offer you motors with optimum drive behaviour and application-oriented options. A fast and reliable solution.



Servo motors

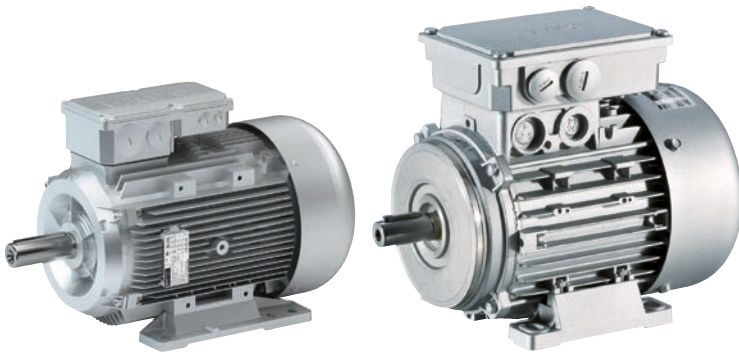



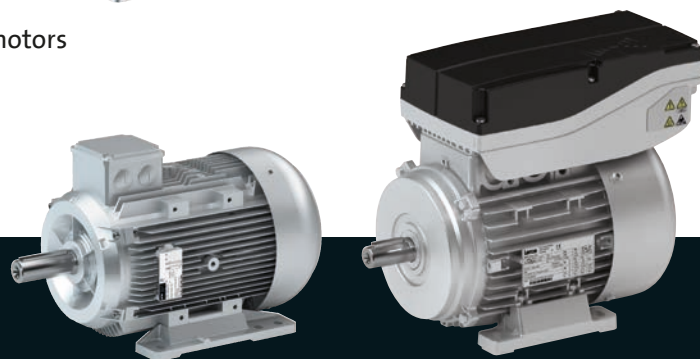

Inverter-operated three-phase AC motors



Mains-operated three-phase AC motors

## Three-phase AC motors

	Mains-operated three-phase AC motors	Lenze Smart Motor m300	Inverter-operated three-phase AC motors	MF three-phase AC motors
				
<b>Power range</b>	0.06 to 45 kW		0.12 to 45 kW	0.55 to 22 kW
<b>Rated torque</b>	0.43 to 290 Nm	1.75 and 5.0 Nm	0.8 to 290 Nm	1.53 to 59.2 Nm
<b>Efficiency class</b>	IE1,2,3		IE1,2,3	
<b>Setting range</b>	Mains operation	Mains operation	1 : 17.5	1 : 24
<b>Axis height</b>	56, 63, 71, 80, 90, 100, 112, 132, 160, 180, 200, 225	63, 80	63, 71, 80, 90, 100, 112, 132, 160, 180, 200, 225	63, 71, 80, 90, 100, 112, 132
<b>Number of different frame sizes available</b>	12	2	11	7
<b>Enclosure</b>	IP54/IP55 and IP65/IP66	IP54 / IP55	IP54/IP55 and IP65/IP66	IP54/IP55 and IP65/IP66
<b>Mass inertia</b>	Medium	Medium	Medium	Medium
<b>Overload capability</b>	Medium	High	Medium	Medium
<b>Power density</b>	Medium	Medium	Medium	High
<b>Cooling</b>				
Forced-ventilated			<input type="checkbox"/>	<input type="checkbox"/>
Naturally ventilated				
Integrated cooling	<input checked="" type="checkbox"/>	<input checked="" type="checkbox"/>	<input checked="" type="checkbox"/>	<input checked="" type="checkbox"/>
<b>Feedback</b>				
Resolver			<input type="checkbox"/>	<input type="checkbox"/>
Incremental encoder			<input type="checkbox"/>	<input type="checkbox"/>
SinCos encoder			<input type="checkbox"/>	<input type="checkbox"/>
<b>Brake</b>				
Spring-applied brake	<input type="checkbox"/>	<input type="checkbox"/>	<input type="checkbox"/>	<input type="checkbox"/>
Permanent magnet brake				
<b>Electronic nameplate</b>				
<b>Ideally suited to</b>	Applications with a constant speed in mains-operated mode.	Applications in the field of horizontal materials handling that are operated at constant speed but require high starting torque. Selecting the speed directly allows the number of different versions to be reduced.	Mains and inverter operation, for universal use in the field of machine building and systems engineering.	Applications which require moderate dynamic performance and a wide setting range despite limited assembly space.

● = standard □ = option ▲ = version

## Servo motors

MCA asynchronous servo motors	MQA asynchronous servo motors	MCM synchronous servo motors	m850 synchronous servo motors	MCS synchronous servo motors
				
0.8 to 53.8 kW	10.6 to 60.2 kW	0.19 to 2.5 kW	2.0 to 9.2 kW	0.25 to 15.8 kW
2 to 280 Nm	66 to 257 Nm	0.6 to 8 Nm	4.8 to 200 Nm	0.5 to 72 Nm
100, 130, 140, 170, 190, 210, 200, 220, 260	200, 220, 260	60, 90, 120	120, 140, 190	60, 90, 120, 140, 190
9	3	3	3	5
IP23 / IP54 / IP65	IP23	IP54	IP54	IP54 / IP65
Low	Very low	Very low	Very low	Very low
Very high	Very high	High	High	Very high
High	Very high	High	High	Very high
▲ (200, 220, 260)	●			□
●		●	●	●
□	□	□	●	□
▲ (200, 220, 260)	□			□
□	□	□	●	□
	□	□	●	
□				□
				●
Environments which require compact units and a high degree of intrinsic operational reliability.	Applications with high motor loads.	Applications that require high dynamic performance, precision and compact dimensions.	Applications that require high dynamic performance, precision and compact dimensions.	Applications which require the highest degree of dynamic performance, precision and compact dimensions.

# Gearboxes: robust power packages.

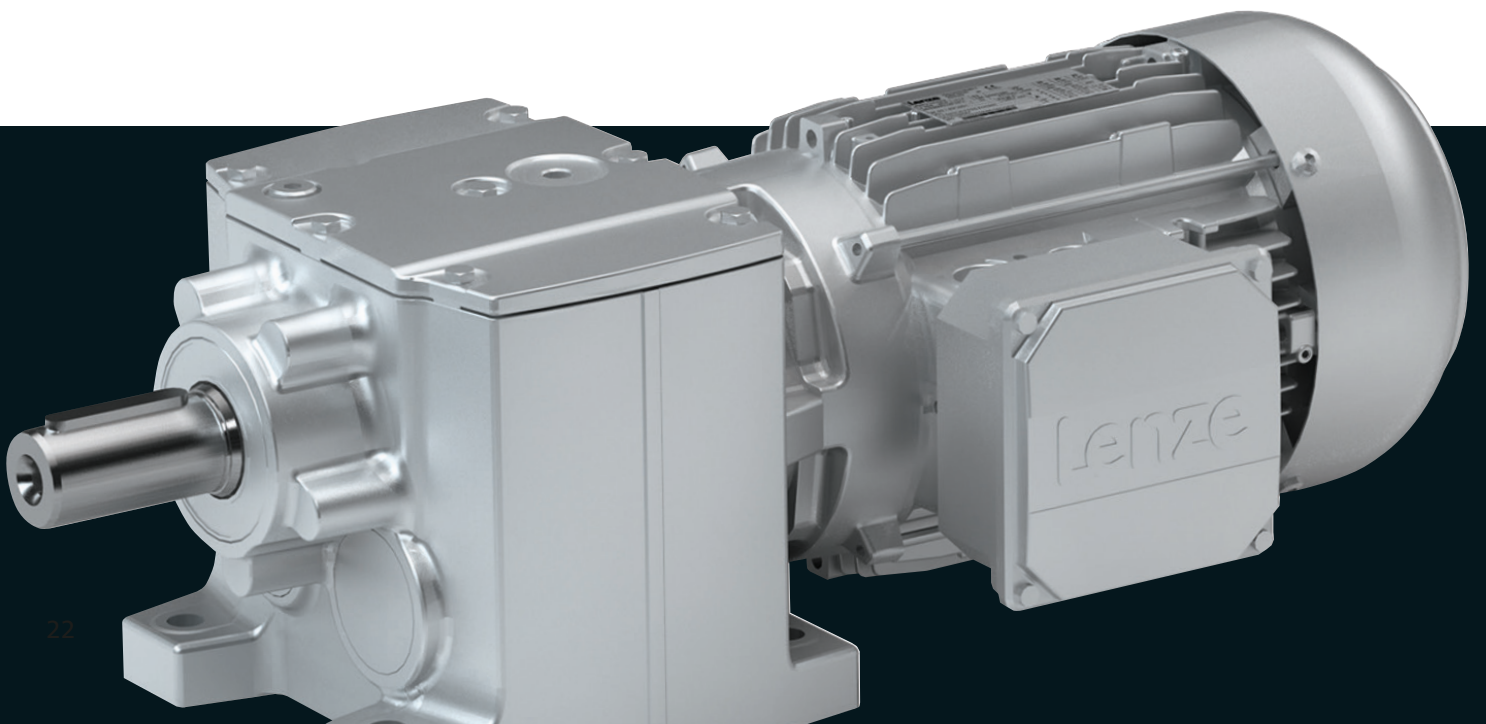



One single motor alone is not a universal solution to all applications. After all, many applications require low speed and high torque, and your machine may need a right-angle drive. The robust, efficient gearboxes and geared motors from Lenze can handle even the toughest of machine tasks here. And if you require couplings, locking bushes or other drive elements for your machine, you are sure to find precisely the right products for your requirements in the scalable product portfolio from Lenze Selection.

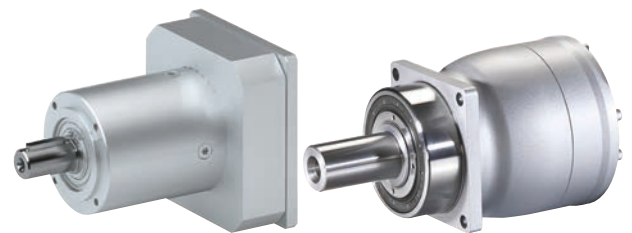

Planetary gearboxes

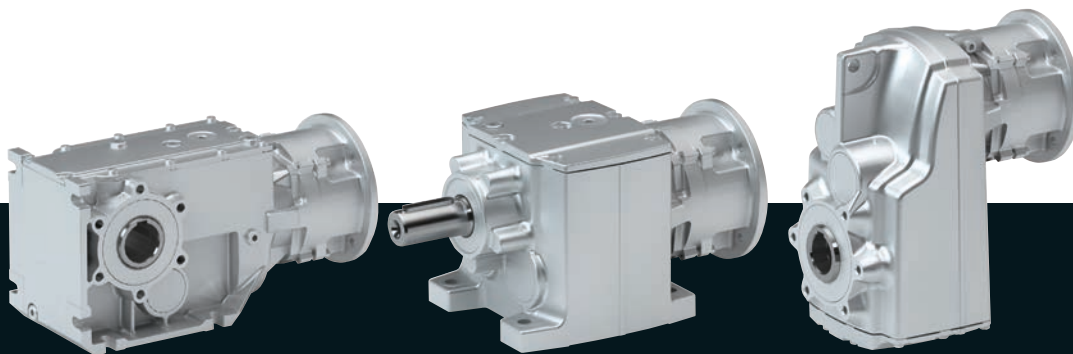

Shaft-mounted helical gearboxes,  
helical gearboxes and bevel gearboxes

## Helical gearboxes, shaft-mounted helical gearboxes and bevel gearboxes

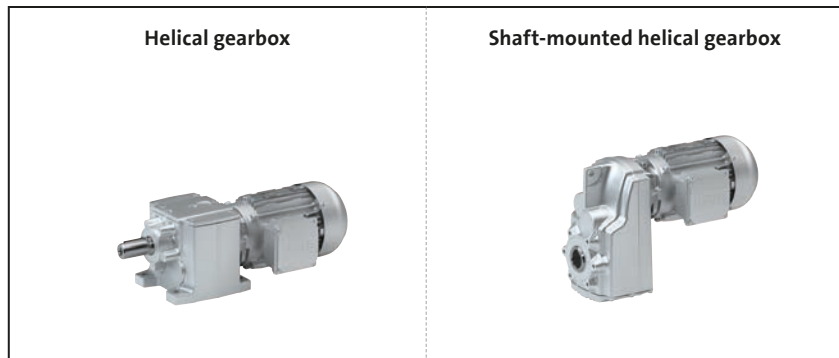



	g500-H	g-500-S
Output range with assigned three-phase AC motors	0.06 to 55 kW	0.09 to 55 kW
Translations	3 to 370	3 to 500
Rated torque	45 to 14,000 Nm	130 to 19,000 Nm
Torque densities	Medium	Medium
Efficiency	High	High
Backlash	Low	Low
Number of different frame sizes available	13	11
<b>Shaft designs</b>		
Solid shaft	●	●
Hollow shaft		●
Shrink disc		●
Flange shaft		
<b>Designs</b>		
Foot mounting	●	●
Flange mounting	●	●

●= standard □= option ▲= version

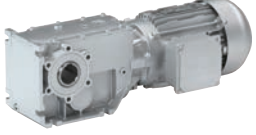

## Planetary gearboxes

<p>Bevel gearboxes</p> 	<p>Planetary gearboxes</p> 	
g500-B	g700	MPR/MPG
0.06 to 55 kW	0.25 to 15.8 kW	0.25 to 15.8 kW
5 to 360	3 to 512	3 to 100
45 to 20,000 Nm	20 to 800 Nm	29 to 390 Nm
Medium	High	High
High	High	High
Low	Very low	Extremely low
12	5	4 each
•	•	•
•		
•		
		•
•		
•	•	•

We are keen to help get your ideas moving forward! Learn more about our approach, our ways of thinking, our vision and how we can make things easier for you in future. Please feel free to contact us directly or visit us at:

**www.  
Lenze.  
com**



