

## DUROLOC7 SHEET METAL CLINCHING UNIT



Use With BTM's  
**15cc Air/Oil  
Booster**



(Unit Shown with optional 360° Hanger.)

The Duroloc7 clinching unit features easy to adjust shut height and interchangeable anvils. Shut height cartridges easily swap to accommodate required material thickness ranges. Interchangeable anvils accommodate a wider range of part cross sections than the Lit-L-Loc unit.

Duroloc7 units are sold separately or as a complete system including a hose and air/oil booster.

### A DUROLOC7 UNIT IS BEST WHEN:

- The part being joined has a small lip, or flange.

Opening	6mm [.25"]
Throat Depth	38mm [1.50"]
Trigger Type	Single
Maximum Operating Pressure	345 BAR [5000 PSI]
Cycle Time	1 second
Unit Weight	5.6 kg [12.4 lbs]
Maximum Combined Material Thickness that can be joined with this unit	2mm [.08"]

### LEARN MORE ONLINE!



Scan the QR Code with a QR code reader, or simply log onto our website using the link below to view more information- including a short video demonstration!

[www.btmcorp.com/duroloc7-units.html](http://www.btmcorp.com/duroloc7-units.html)

### TYPICAL APPLICATIONS FOR A DUROLOC7 UNIT:

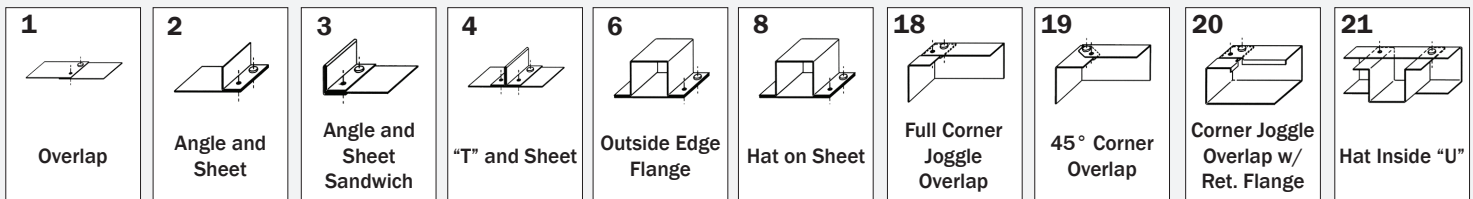

### ROTATION HANGERS ARE AVAILABLE FOR ASSISTING OPERATOR PRODUCTIVITY.

#### 180° HANGER

This hanger allows a Duroloc7 Unit to rotate 180° on a single axis.



#### 360° HANGER

This hanger allows a Duroloc7 Unit to rotate a full 360° on a single axis.

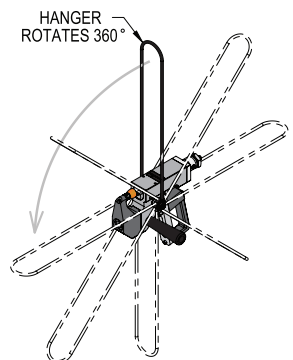

Duroloc7 Dimensions on the back of this flyer ▶

LEARN MORE ONLINE!



www.btmcorp.com/  
duroloc7-units.html

## DUROLOC7

AIR/OIL BOOSTER POWERED UNIT

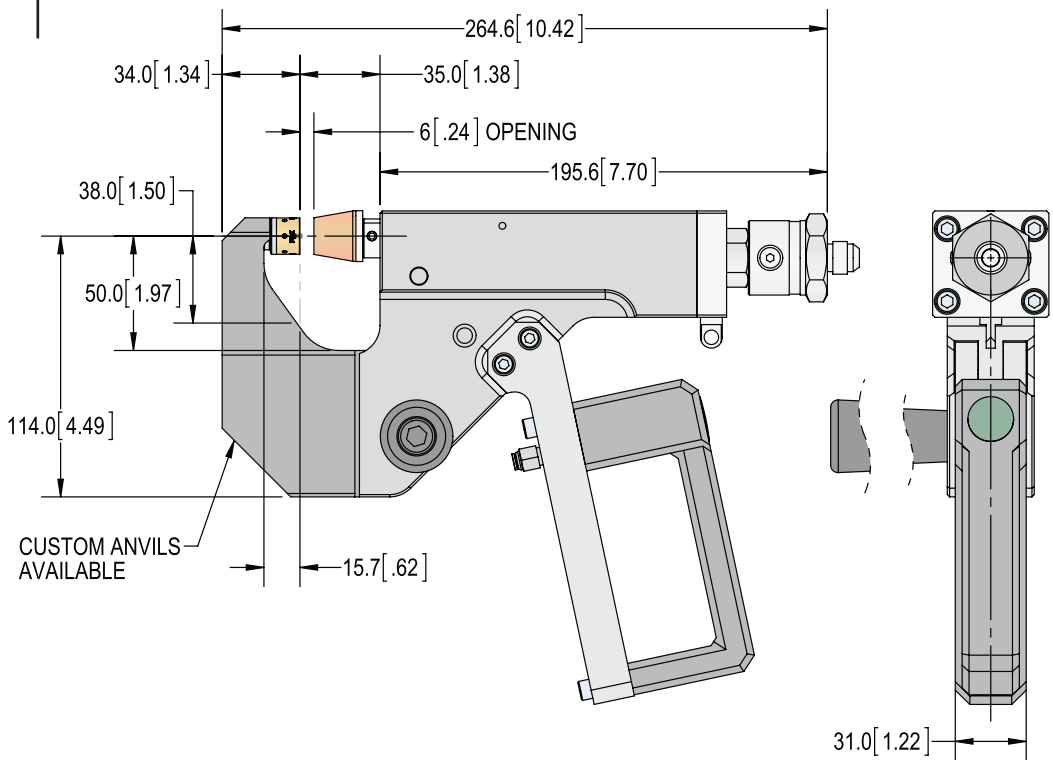
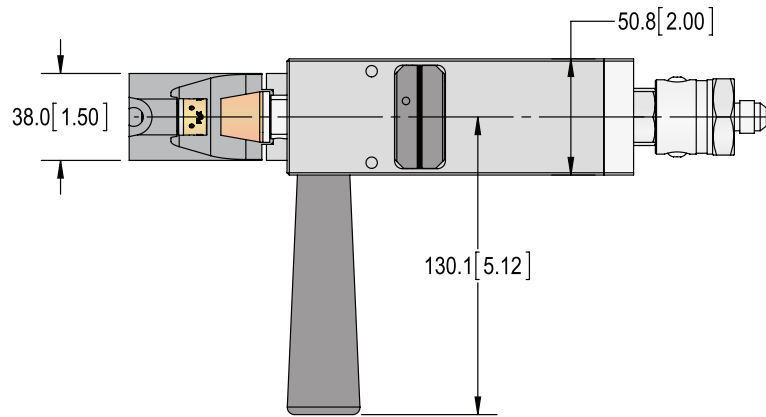

### HANDLE OPTIONS

12° HANDLE (STANDARD)

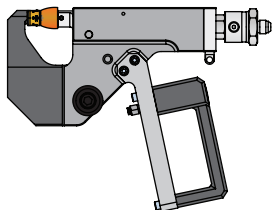
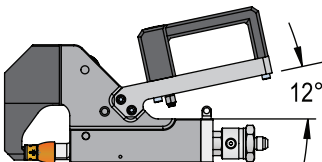

STRAIGHT HANDLE OPTION

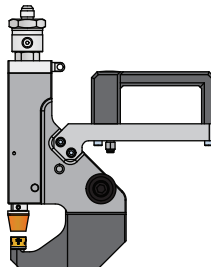
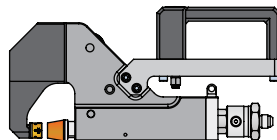

NEGATIVE 15° HANDLE

