

Anglia Handling Services Ltd.

VISIT OUR OFFICE & FACTORY IN BIGGLESWADE



VISIT OUR WEB SITE & SHOP

WHERE YOU CAN BROWSE & BUY ONLINE

<h1>Anglia Handling Services Ltd.</h1>		
Montgomery Way Stratton Business Park Biggleswade Bedfordshire SG18 8QB	Tel: 01767-312125 Fax: 01767-601375 e - mail: sales@angliahandling.co.uk www.angliahandling.co.uk	

Buy Online – the best way to buy



HOME



SITE MAP



INFO



SEARCH



VIEW CART



CHECKOUT



SEND MAIL

CONTENTS *(revision 06)*

SECTION	PAGE
INTRODUCTION	7
1. GENERAL INFORMATION	
Repair, Test and Certification	8
Examination and Testing	9
Hire	10
2. WIRE ROPES	
Wire Rope and Slings	11
Wire Rope Sling Types	12
Safe Working Loads	13
Wire Rope Grips	14
Wire Rope Grips and Thimbles - Stainless Steel	15
Rigging and Straining Screws	16
Rigging Screws - Stainless Steel	17
3. EYEBOLTS	
Eyebolts to DIN 580	18
Dynamo Eyebolts to BS 4278	19
Collared Eyebolts to BS 4278 - Metric	20
Collared Eyebolts to BS 4278 - BSW	21
Collared Eyebolts with Egg Links	22
Eye and Bow Nuts	23
Eyebolts and Eyenuts - Stainless Steel	24
Starpoint Eyebolts and Eyenuts	25
Rotating Lifting Points	26
Specialist Lifting Eye Range	27
4. SHACKLES	
Small Dee and Bow Shackles to BS 3032	28
Large Dee and Bow Shackles to BS 3032	29
Alloy Dee and Bow Shackles to EN13889	30
Shackles - Stainless Steel	31
Carbine Hooks and Quick Links	32
5. CHAIN SLINGS	
Popular Assemblies	33
Working Load Limits – Grade 80	34
Components	35
Components	36
Components	37
Working Load Limits – Grade 100	38
Components	39
Short Link, Long Link and Straight Link Chain	40
Stainless Steel chain and pump chain	41

SECTION	PAGE
6. WEBBING SLINGS	
Flat Webbing Slings	42
Roundslings and Endless Flat Webbing Slings	43
Cargo Restraints	44
7. MANUAL HOISTS	
Hand Chain Blocks	45
Lever Hoists	46
Manual and Powered Winches	47
Tirfor Pulling and Lifting Machines	48
Pulley Blocks	49
8. ELECTRIC HOISTS	
Electric Chain Hoists	50
Electric Wire Rope Hoists	51
Special Hoists	52
9. AIR HOISTS	
Air Chain Hoists	53
10. CRANES	
Jib Cranes	54
Overhead Travelling Cranes	55
Modular Cranes	56
Mobile Gantries	57
Aluminium Gantries and Tripods	58
11. LIFTING BEAMS	
Lifting / Spreader Beams	59
12. LIFTING HOOKS	
'C' Hooks	60
Pipe Hooks and Safety Hook	61
13. VACUUM LIFTING	
Powered Vacuum Lifting Beams	62
Self-Suction Vacuum Lifting Beams	63
VacuEasylift Vacuum Lifting Hoists	64
14. LIFTING MAGNETS	
Permanent Lifting Magnets	65
Battery Lifting Magnets	66

SECTION	PAGE
15. LIFTING CLAMPS & GRABS	
Pallet Forks and Brick Grabs	67
Lifting and Girder Clamps	68
Lifting and Girder Clamps	69
Lifting and Girder Clamps	70
Lifting and Girder Clamps	71
Lifting and Girder Clamps	72
16. DRUM HANDLING	
Drum Lifting and Turning	73
17. SAFETY EQUIPMENT	
Safety Harnesses	74
Anchor Points	75
Accessories	76
Tripods and Easylift Tripod System	77
Davits, Lifeline Systems and Guard Rails	78
18. WEIGHING EQUIPMENT	
Load Cells and Load Blocks	79
Mini Weighers	80
Platform Scales	81
Pallet Truck Weighers	82
19. JACKS	
Hydraulic Jacks	83
Hydraulic & Manual Jacks and Roller Pinch Bars	84
20. HYDRAULIC EQUIPMENT	
Pumps and Cylinders	85
Hydraulic Accessories	86
21. TRUCKS, SCISSOR LIFTS & STAIR CLIMBERS	
Pallet and Stacker Trucks	87
Stacker Trucks	88
Fork Truck Attachments	89
Fork Truck Attachments	90
Fork Truck Attachments	91
Scissor Lifts - Static and Mobile	92
Stair Climbers	93
22. LOAD MOVING EQUIPMENT	
Metal Roller Skates	94
Nylon Roller Skates	95
Air Skates and Easy Movers	96

SECTION	PAGE
23. CONVEYOR SYSTEMS	
Gravity and Powered Roller Systems	97
24. REEL HANDLING	
Reel Lifting and Turning Systems	98
25. ELECTRICAL EQUIPMENT	
Festoon and Conductor Systems	99
26. ACCESS EQUIPMENT	
Ladders and Steps	100
Warehouse Steps	101
27. MANHOLE LIFTING EQUIPMENT	
Manhole Lifting Devices	102
Manhole Lifting Devices	103
28. MISCELLANEOUS	
Carrymate Panel and Door Lifters	104

Introduction

Your Problem is our Business!

Anglia Handling was established in 1987 and is based in East Anglia, UK. We are a progressive company offering a wide range of products in the specialised fields of:

- Lifting
- Materials Handling
- Construction
- Personal Protection
- Access
- Weighing

We are able to respond quickly and efficiently to your requirements whether it is a single eyebolt or an overhead crane. We are members of LEEA (Lifting Equipment Engineers Association), which requires us to comply with their Code of Practice standards.

Our product range includes specialised equipment such as vacuum lifting devices and reel lifting and turning solutions. Where a standard product is not suitable our design department can modify an existing product or manufacture a bespoke item. We can also build, install, commission and test overhead cranes, jib cranes, gantries and runway beams to suit your requirements.

We also offer the following services:

- Inspection
- Repair
- Testing
- Certification
- Servicing
- Hire

These services can be carried out on site at your premises or within our own workshop in Bedfordshire.

Please visit our website at www.angliahandling.co.uk where you will find a comprehensive range of products and information with a Shop where you can buy online.



Repair, Test and Certification

We operate a comprehensive maintenance service for all lifting tackle including overhead cranes, electric chain and wire rope hoists, hand chain blocks, lever hoists, chain slings, wire rope slings, winches, Tirfor winches, lifting beams, scissor lift tables, hydraulic jacks, trucks and associated equipment etc.

Our service includes:

1. Inspections and the issue of detailed reports.
2. Repairs of ALL makes and types of Lifting and Materials Handling Equipment.
3. Records kept of all Equipment received for Repair and Test.
4. Advice given when inspections are due.
5. Works facilities always available for urgent repairs and modifications.
6. Advice from 'Lifting Equipment Engineers Association' qualified engineers who specialise in Lifting, Materials Handling and Height Safety problems.
7. Compilation and maintenance of Lifting Equipment Registers.

Is your Lifting Equipment properly maintained?

Regular maintenance by Anglia Handling Services Ltd will:

- Reduce the chance of an accident.
- Reduce the costs of repairs.
- Increase your productivity.
- Automatically meet LOLER and PUWER Regulations.



**FOR YOUR SAFETY AND THAT OF OTHERS
LET US MAINTAIN YOUR LIFTING EQUIPMENT**

Examination and Testing

SUMMARY OF REQUIREMENTS FOR TAKING INTO USE

There is no distinction between Lifting Accessories and Lifting Equipment. The manufacturer, or importer into the EEA, will issue the EC Declaration and affix the CE Mark. If the user holds the Declaration, the Declaration is less than 12 months old and the equipment is new and unused he may take the item into use for the first time. In all other cases he must have it thoroughly examined and the examination report must comply with the requirements given in Schedule 1 of LOLER.

SUMMARY OF REQUIREMENTS FOR PERIODIC EXAMINATION

Once in use the equipment must be either examined periodically or in accordance with a written scheme of examination drawn up by a competent person. For lifting accessories the period is no greater than 6 months and for lifting equipment it is no greater than 12 months. For lifting equipment intended for lifting persons the period is no greater than 6 months.

SUMMARY OF REQUIREMENTS FOR LOAD TESTING

There are no legal requirements for periodic load testing. Testing is a matter for the manufacturer when producing a new item or at the discretion of the competent person once the item is in service. In this respect British Standards have no legal status, a Harmonised European Standard on the other hand has a quasi-legal status and a manufacturer can use this as his way of demonstrating compliance with the Machinery Directive. A user has a legal obligation to ensure equipment he introduces into the work place complies with the Directive.

Manufacturers, including users who produce an item for their own use, must comply fully with the Supply of Machinery (Safety) Regulations (please refer to paragraph 1 above). Users must comply fully with both PUWER and LOLER. PUWER applies to ALL equipment and LOLER then gives the specific additional requirements necessary for lifting equipment. Please refer to the full legislation to ensure all obligations are met.

DESIGN LOADS FOR LIFTING BEAMS AND SPREADERS

Safe Working Load	Proof Load at Least Equal to
Up to and including 10 tonnes	S.W.L. plus 100%
Over 10 tonnes	S.W.L. x 1.04 plus 9.6 tonnes

Please note that these are the currently accepted loads if a load test is to be made to a new or repaired beam.

Hire

We offer the following Lifting Equipment for Hire.

- Mobile Gantries
- Beam Clamps
- Hydraulic jacks
- Electric Chain & Wire Rope Hoists
- Skates
- Tirfor Winches
- Hand Chain Blocks
- Beam Trolleys
- Lever Hoists
- Genie Material Lifts
- Fork Truck Jib Attachments
- Ancillary Equipment



Beam Clamp



Mobile Gantry



Bottle Jack



Lever Hoist



Tirfor Winch



Toe Jack



Hand Chain Block



Beam Trolley



Metal Roller Skates



Fork Truck Jib Attachment

Wire Rope and Slings

We have an extensive rigging facility enabling us to provide the following services:

- Manufacture of wire rope slings and nets.
- Long splicing – on site or in our works.
- Hand splicing, socketing and fitting.
- Supply and fitting of new ropes on cranes, hoists and contractors equipment.

Due to the extremely wide range of types and constructions of wire rope it is impracticable in a catalogue of this size to illustrate all that is available and for this reason we recommend that you consult our technical sales personnel when wire ropes are required.

To enable us to advise you, the following information should be provided:

1. The purpose for which the rope will be used.
2. Length.
3. Diameter.
4. Construction – if known.
5. Bright or Galvanised.
6. Breaking load or safe working load required.
7. Type of fitting required.
8. If fitted at each end the points between which measurements are to be taken.

SUBSTANTIAL QUANTITIES OF POPULAR SIZES AND CONSTRUCTION ARE ALWAYS IN STOCK AND ROPES TO SUIT INDIVIDUAL REQUIREMENTS CAN BE QUICKLY OBTAINED.

Examples of typical types and constructions available.



6 x 19 (12/6/1)

Standard flexible hoisting rope combining moderate flexibility with high strength. Suitable for most hoists and cranes or wherever rope is continually passing over drums and sheaves. Available with fibre core or I.W.R.C.

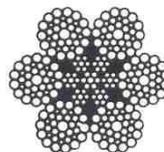

6 x 36
(14/7 and 7/7/1)

Highly flexible hoisting rope with high strength. Used extensively for hoists, overhead cranes, winches and excavating equipment. Available with fibre core or I.W.R.C.

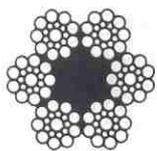

6 x 19 (9/9/1)

A stiffer construction than 6 x 19 (12/6/1) suitable for hoists and cranes with comparatively large drum or sheave diameters. Used extensively for making slings of all types.

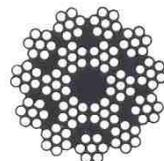

17/7 non rotating

This construction is used mainly on high lift cranes, where rope twist or spin under load would be a problem. Unlike many other ropes the ends do not need to be fixed to prevent rotation. Available with fibre core or I.W.R.C.

It should be noted that fibre core ropes retain lubricant much longer in adverse conditions than ropes with independent wire rope core (I.W.R.C.).

Wire Rope Sling Types



AHS 1
SOFT EYE EACH END



AHS 2
THIMBLE EYE EACH END



AHS 3
THIMBLE EYE ONE END, SOFT EYE OTHER END



AHS 4
THIMBLE EYE ONE END, SOFT EYE
OTHER END FITTED WITH CHOKER HOOK



AHS 5
SOFT EYE ONE END AND SLING HOOK OTHER END

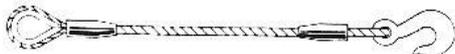

AHS 6
THIMBLE EYE ONE END AND SLING HOOK OTHER END



AHS 7
RING ONE END THIMBLE AND SAFETY HOOK OTHER END

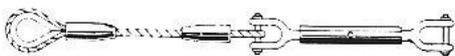

AHS 8
THIMBLE EYE ONE END, SOFT EYE
AND RIGGING SCREW OTHER END

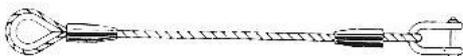

AHS 9
THIMBLE EYE ONE END, THIMBLE
EYE AND SHACKLE OTHER END



AHS 10
CLOSED SOCKET ONE END,
OPEN SOCKET OTHER END



AHS 11
TWO LEG SLING WITH MASTER LINK AND SLING HOOKS



AHS 12
THREE LEG SLING WITH MASTER LINK AND SLING HOOKS



AHS 13
FOUR LEG SLING WITH MASTER LINK AND SLING HOOKS



AHS 14
ENDLESS SLING

Safe Working Loads

Based on 1960 tensile grade; 6x36WS-IWRC (steel core) construction and having ferrule secured eye terminations.

LOAD CHART

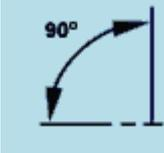
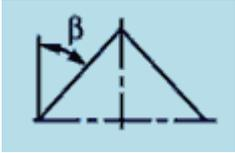
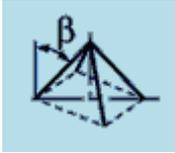
							
Wire Rope Diameter (mm)	Minimum Breaking Load (tonnes)	WLL Single Leg	WLL 2-Leg Sling		WLL 3 or 4-Leg		WLL Choke Hitch
		0° (tonnes)	0-45° (tonnes)	45-60° (tonnes)	0-45° (tonnes)	45-60° (tonnes)	0° (tonnes)
8	4.56	0.82	1.15	0.82	1.72	1.23	1.31
9	5.76	1.04	1.45	1.04	2.18	1.56	1.66
10	7.12	1.28	1.79	1.28	2.69	1.92	2.05
13	12.00	2.16	3.02	2.16	4.54	3.24	3.46
16	18.30	3.29	4.61	3.29	6.92	4.94	5.27
18	23.00	4.14	5.80	4.14	8.69	6.21	6.62
20	28.50	5.13	7.18	5.13	10.77	7.70	8.21
22	34.50	6.21	8.69	6.21	13.04	9.32	9.94
24	41.00	7.38	10.33	7.38	15.50	11.07	11.81
26	48.10	8.66	12.12	8.66	18.18	12.99	13.85
28	55.80	10.04	14.06	10.04	21.09	15.07	16.07
32	72.90	13.12	18.37	13.12	27.56	19.68	21.00
36	92.20	16.60	23.23	16.60	34.85	24.89	26.55
38	103.00	18.54	25.96	18.54	38.93	27.81	29.66
40	114.00	20.52	28.73	20.52	43.09	30.78	32.83
44	138.00	24.84	34.78	24.84	52.16	37.26	39.74
48	164.00	29.52	41.33	29.52	61.99	44.28	47.23
52	192.00	34.56	48.38	34.56	72.58	51.84	55.30
Leg Factor KL		1	1.4	1	2.1	1.5	1.6

KL is the leg factor related to the number of legs and the angle to the vertical.

Larger diameter wire rope assemblies available on request.

The Safe Working Load (SWL) will normally be equal to the Working Load Limit (WLL), although in some instances it may be less e.g. if the sling is used in Choke Hitch the SWL will equal the WLL x 0.8.

Wire Rope Grips

Commercial Pattern

Rope Dia. inches	Rope Dia. mm	a mm	b1 mm	b2 mm	d mm	h1 mm	h2 mm	l mm
1/8	3	12	5	10	4	20	10	21
3/16	5	13	6	11	5	24	10	23
1/4	6	15	8	12	5	28	11	26
5/16	8	19	10	14	6	34	15	30
3/8	10	22	11	18	8	42	17	34
7/16	11	22	12	19	8	44	18	36
1/2	13	30	14	23	10	55	21	42
9/16	14	30	15	23	10	57	22	44
5/8	16	33	17	26	12	63	26	50
3/4	19	38	20	29	12	75	30	54
7/8	22	44	23	33	14	85	34	61
1	26	45	27	35	14	95	37	65
1.1/8	30	50	32	37	16	110	43	74
1.1/4	34	55	36	42	16	120	50	80
1.1/2	40	60	42	45	16	140	55	88
1.7/8	50	75	54	48	19	193	75	112

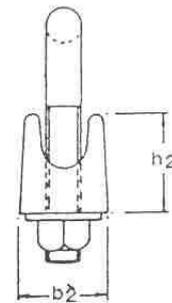
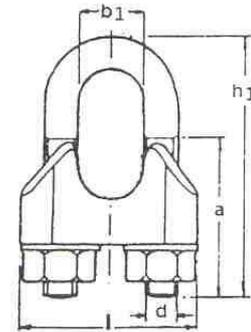

According to EN 13411-5 Type A

Rope Dia. mm	a mm	b1 mm	b2 mm	d mm	h1 mm	h2 mm	l mm
5	14	8	13	4	25	13	25
6.5	17	9	16	5	32	14	30
8	20	11	20	7	41	18	39
10	24	13	20	7	46	21	40
12	28	14	25	10	56	24	50
13	29	18	28	11	64	29	55
14	31	16	30	12	66	28	59
16	35	22	32	12	76	35	64
19	36	25	33	12	83	40	68
22	40	27	34	14	96	44	74
26	50	28	38	18	111	51	84
30	55	36	41	18	127	59	95
34	60	38	45	22	141	67	105
40	65	44	49	24	159	77	117

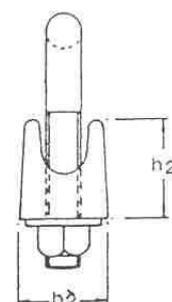
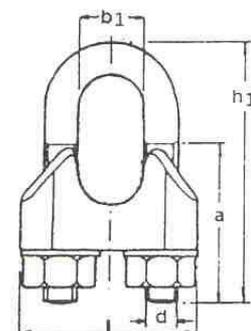

Wire Rope Grips – Stainless Steel

Stainless Steel Wire Rope Grips

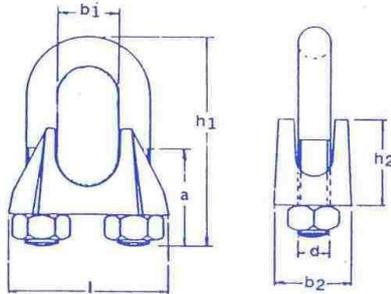

Rope Ø (mm)	a (mm)	b1 (mm)	b2 (mm)	d (mm)	h1 (mm)	h2 (mm)	l (mm)	Weight/100 (kg)
2	10	5	10	3	17	10	17	0.9
3	12	5	10	4	20	10	21	1.0
4	13	6	11	4	23	11	21	1.3
5	13	6	11	5	24	10	23	1.5
6	15	8	12	5	28	11	26	2.1
8	19	10	14	6	34	15	30	4.1
10	22	11	18	8	42	17	34	6.8
13	30	14	23	10	55	21	42	13.0
16	33	17	26	12	63	26	50	21.0
19	38	20	29	12	75	30	54	28.0
22	44	23	33	14	85	34	61	40.0
24	45	27	35	14	95	37	65	42.0

Thimbles

Stainless Steel Thimbles

Rope Ø (mm)	A (mm)	B (mm)	C (mm)	E (mm)	Weight/100 (kg)
2	7	12	21	2	0.2
3	10	14	23	3	0.4
4	11	16	25	4	0.6
5	13	21	32	5	0.8
6	15	26	39	6	1.4
8	18	35	48	8	2.8
10	25	42	55	10	4.8
12	29	48	66	12	8.0
16	35	62	84	16	15.1
20	43	73	99	20	21.7
22	50	84	110	22	32.0
24	54	85	120	24	66.0

Rigging Screws *Closed Body*

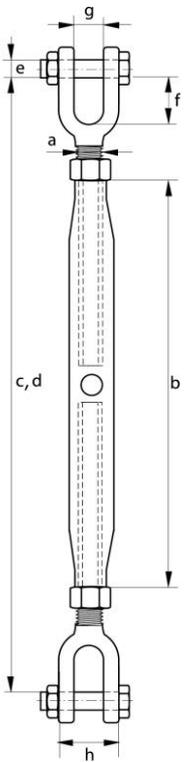

a (mm)	WLL (tonnes)	b (mm)	c (mm)	d (mm)	e (mm)	f (mm)	g (mm)	h (mm)
6	0.20	100	175	255	5	19	7	20
8	0.32	108	199	282	6	25	9	24
10	0.50	125	222	320	8	26	10.5	28
12	0.70	195	320	479	10	32	13	34
16	1.20	230	388	572	12	39	18	42
20	1.50	270	454	672	16	46	20	51
22	2.20	295	490	730	20	55	25	55
24	3.20	325	558	819	22	63	30	70
33	4.80	370	681	977	30	85	38	82
39	6.00	400	710	1017	33	86	45	85
45	8.50	407	810	1170	39	86	48	96
48	10.00	407	855	1215	45	98	50	101

Options: Jaw / Jaw, Eye / Jaw, Eye / Eye
 Material: Mild steel
 Finish: Hot dip galvanised
 Note: End fittings of 6 and 8 mm screws are electro galvanised

Straining Screws *Commercial Pattern*

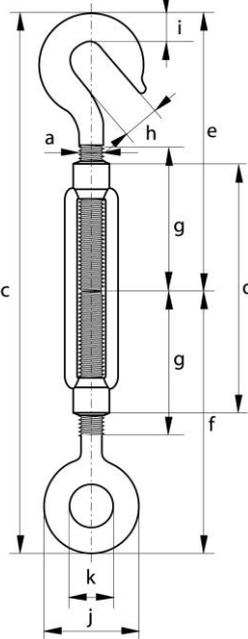

a (mm)	b (mm)	c mm	d mm	e mm	f (mm)	g (mm)	h (mm)	i (mm)	j (mm)	k (mm)
6	172	258	110	77	80	55	8	8	20	9
8	184	264	110	85	84	57	10.5	10	22	10
10	222	311	125	106	105	68	13	11	31	14
12	241	324	125	117	111	70	16	13	35	16
16	311	427	170	144	150	88	20	17	47	22
20	358	490	200	170	167	105	21	21	52	24
24	453	630	255	215	205	135	26	33	65	27
30	495	660	255	240	220	135	34	35	71	31
33	545	744	295	260	245	148	38	40	88	36
36	597	782	295	275	277	158	46	45	94	38

Material: Drop forged mild steel
 Standard: DIN 1480
 Finish: Electro galvanised

Rigging Screws – Stainless Steel

Stainless Steel Rigging Screws - Commercial Pattern - Closed Body - Jaw and Jaw

	a (mm)	b (mm)	c (mm)	d (mm)	e (mm)	f (mm)
	6	210	155	95	6.2	7.5
	8	240	180	105	8.7	10
	10	270	220	125	9.7	12
	12	360	255	150	12.7	14
	16	450	320	190	16	16
	20	450	355	210	19	20

Material: Stainless steel AISI 316
 Finish: Polished
 Note: Not to be used for lifting purposes

Stainless Steel Rigging Screws - Commercial Pattern - Open Body - Jaw and Jaw

	a (mm)	b (mm)	c (mm)	d (mm)	e (mm)	f (mm)
	5	170	115	70	5	6
	6	200	130	90	6	7
	8	250	160	120	8	10
	10	320	200	150	10	12
	12	380	250	170	12	13

Material: Stainless steel AISI 316
 Finish: Polished
 Note: Not to be used for lifting purposes

Stainless Steel Straining Screws - Commercial Pattern - Open Body – Hook and Eye

	a (mm)	b (mm)	c (mm)	d (mm)	e (mm)	f (mm)	h (mm)	i (mm)	k (mm)
	5	120	170	70	58	56	8	5	8
	6	150	210	90	73	71	9	6	10
	8	200	290	120	98	95	11	8	14
	10	240	355	150	117	118	12	9	16
	12	310	470	200	157	154	14	11	18
	16	390	590	250	186	190	16	15	26

Material: Stainless steel AISI 316
 Finish: Polished
 Note: Not to be used for lifting purposes

Eyebolts to DIN 580

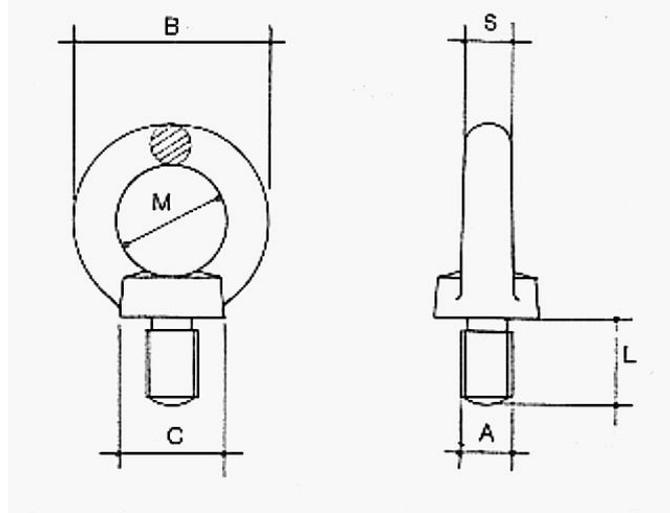

Metric Coarse Thread

SWL (KGs)	A (mm)	B (mm)	C (mm)	L (mm)	M (mm)	S (mm)	Weight (KGs)
70	6	36	20	13	20	8	0.06 *
140	8	36	20	13	20	8	0.06
230	10	45	25	17	25	10	0.11
340	12	54	30	20.5	30	12	0.18
490	14	63	35	27	35	14	0.28 *
700	16	63	35	27	35	14	0.28
900	18	72	40	30	40	16	0.41 *
1200	20	72	40	30	40	16	0.42
1500	22	81	45	35	45	18	0.67 *
1800	24	90	50	36	50	20	0.84
2500	27	90	50	36	50	20	1.22 *
3200	30	108	65	45	60	24	1.66
4300	33	108	65	45	60	24	2.16 *
4600	36	126	75	54	70	28	2.65
6100	39	126	75	54	70	28	3.34 *
6300	42	144	85	63	80	32	4.03
8000	45	144	85	63	80	32	5.21 *
8600	48	166	100	68	90	38	6.32
11500	56	184	110	78	100	42	8.80
16000	64	206	120	90	110	48	12.40

Sizes marked * are additional and proportional to the specification

Direction of pull	Maximum Loadings by piece lifted in Kgs												
	1 bolt	140	230	340	700	1200	1800	3600	5100	7000	8600	11500	16000
0°	2 bolts	95	170	240	500	830	1270	2600	3700	5000	6100	8300	11000

- Other thread sizes are also available.
- Also available in Stainless Steel – see page 24.

Dynamo Eyebolts to BS 4278 1984

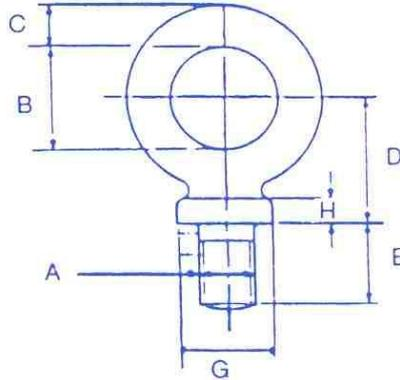

Metric Coarse Thread

SWL (KGs)	A (mm)	B (mm)	C (mm)	D (mm)	E (mm)	G (mm)	H (mm)
*100	6	22	9	27	18	17	5
*150	8	22	9	27	18	17	5
*250	10	22	9	27	18	17	5
320	12	22	9	27	18	17	5
*500	14	32	13	41	28	29	9
630	16	29	11	34	23	23	6
*1000	18	40	15	47	32	32	9
1250	20	40	15	47	32	32	9
*1600	22	44	17	53	35	35	14
2000	24	51	19	60	40	40	12
3200	30	64	24	76	51	51	14

BSW Thread

SWL (KGs)	A (inches)	B (inches)	C (inches)	D (inches)	E (inches)	G (inches)	H (inches)
100	1/4	7/8	3/8	1.1/16	3/4	3/4	1/4
150	5/16	7/8	3/8	1.1/16	3/4	3/4	1/4
250	3/8	7/8	3/8	1.1/16	3/4	3/4	1/4
500	1/2	1.1/16	7/16	1.3/8	1	1	5/16
800	5/8	1.1/4	1/2	1.5/8	1.1/8	1.1/8	3/8
1200	3/4	1.9/16	11/16	2.1/8	1.1/4	1.7/16	1/2
1600	7/8	1.3/4	11/16	2.5/16	1.3/8	1.3/8	9/16
2200	1	2	13/16	2.7/16	1.13/16	1.5/8	1/2
2650	1.1/8	2.3/8	1	2.7/8	2.1/16	2.1/8	3/4
3500	1.1/4	2.3/8	1	2.7/8	2.1/16	2.1/8	3/4

Sizes marked * are additional and proportional to the specification.

Long shank Collared and Dynamo eyebolts are also available.

Other thread sizes are also available.

Collared Eyebolts to BS 4278 1984

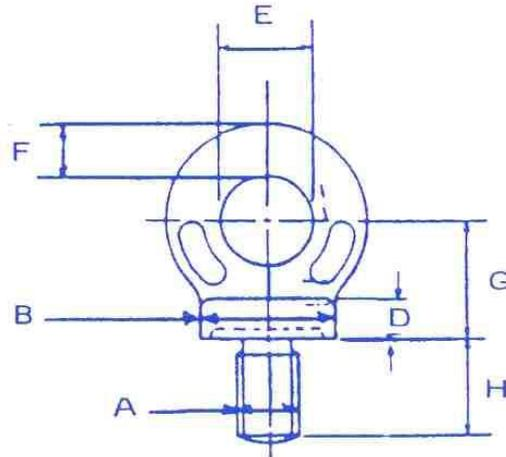

Metric Coarse Thread

SWL (KGs)	A (mm)	B (mm)	D (mm)	E (mm)	F (mm)	G (mm)	H (mm)
*100	6	22	7	15	9	19.5	18
*150	8	22	7	15	9	19.5	18
*250	10	22	7	15	9	19.5	18
400	12	22	7	15	9	19.5	18
*500	14	29	10	20	12	26	23
800	16	29	10	20	12	26	23
*1000	18	36	12	24	14	32	28
1600	20	40	14	27	16	35.5	32
*1600	22	45	14	30	17	41	35
2500	24	52	17	35	21	45.5	40
*2500	27	58	20	39	23	51.5	46
4000	30	65	22	44	26	58	51
*4000	33	72	24	48	29	64	56
6300	36	81	27	54	32	72	63
*6300	39	86	29	57	33	75.5	67
8000	42	101	34	68	40	90	79
*8000	45	101	34	68	40	90	79
*10000	48	101	34	68	40	90	79
12500	52	115	38	76	46	102	89
16000	56	128	43	86	51	114	100
20000	64	144	48	96	58	128	112

Sizes marked * are additional and proportional to the specification.

Long shank Collared eyebolts are also available.

Other thread sizes are also available.

Collared Eyebolts to BS 4278 1984

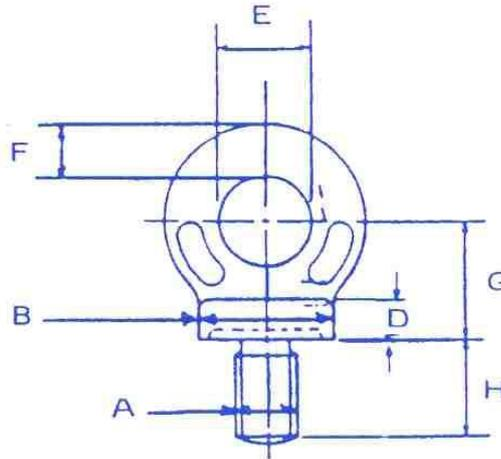

BSW Thread

SWL (KGs)	A (inches)	B (mm)	D (mm)	E (mm)	F (mm)	G (mm)	H (mm)
*100	1/4	22	7	15	9	19.5	18
*150	5/16	22	7	15	9	19.5	18
*250	3/8	22	7	15	9	19.5	18
500	1/2	29	10	20	12	26	23
*900	5/8	36	12	24	14	32	28
1400	3/4	45	14	30	18	40	35
2000	7/8	52	17	35	21	45.5	40
2750	1	58	20	39	23	51.5	46
3500	1.1/8	65	22	44	26	58	51
4500	1.1/4	72	24	48	29	64	56
6500	1.1/2	81	27	54	32	72	63
9000	1.3/4	101	34	68	40	90	79
12000	2	115	38	76	46	102	89

Long shank Collared eyebolts are also available.

Other thread sizes are also available.

Maximum recommended safe working loads for Collared eyebolts when used in pairs.

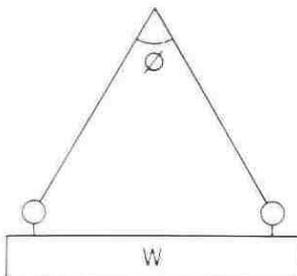

Safe working load (single eyebolt, vertical)	Maximum load 'W' to be lifted by a pair of eyebolts when the angle between the sling legs is θ .		
	$0^\circ < \theta < 30^\circ$	$30^\circ < \theta < 60^\circ$	$60^\circ < \theta < 90^\circ$
Tonne	Tonne	Tonne	Tonne
1.0	1.3	0.8	0.5
1.6	2.0	1.25	0.8
2.5	3.2	2.0	1.25
4.0	5.0	3.2	2.0
6.3	8.0	5.0	3.2
8.0	10.0	6.3	4.0
10.0	12.5	8.0	5.0
12.5	16.0	10.0	6.3
16.0	20.0	12.5	8.0
20.0	25.0	16.0	10.0
25.0	32.0	20.0	12.5
Reduction factor	0.63	0.40	0.25

Collared Eyebolts with Egg Links

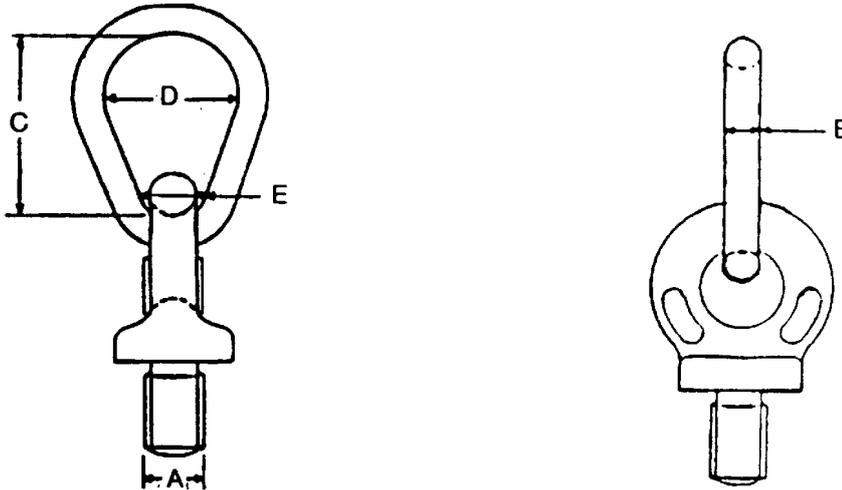

METRIC COURSE THREADS

Vertical SWL Tonnes	A mm	B mm	C mm	D mm	E mm	Weight Each kg
0.15	8	11	70	35	9	0.22
0.25	10	11	70	35	9	0.22
0.40	12	11	70	35	9	0.23
0.80	16	16	100	50	12	0.62
1.60	20	19	120	55	16	1.17
2.50	24	25	152	76	21	2.00

BSW THREADS

Vertical SWL Tonnes	A in	B in	C in	D in	E mm	Weight Each kg
0.25	3/8	7/16	2.3/4	1.3/8	9	0.21
0.50	1/2	7/16	2.3/4	1.3/8	12	0.29
0.90	5/8	5/8	4	2	14	0.73
1.40	3/4	3/4	4.3/4	2.1/4	18	1.19
2.00	7/8	7/8	5.3/8	2.5/8	21	1.91

Other thread sizes are also available.

Eye and Bow Nuts

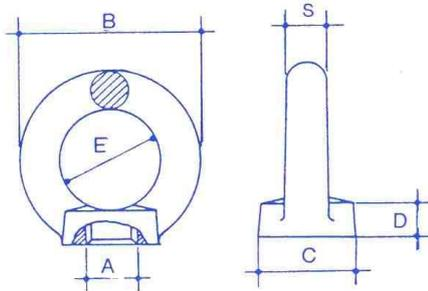

Eye Nut

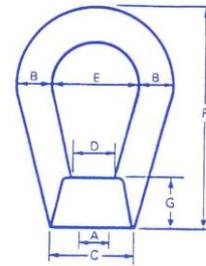

Bow Nut

Eye Nuts - Metric Coarse Thread

SWL (kgs)	A (mm)	B (mm)	C (mm)	D (mm)	E (mm)	S (mm)
70	6	36	20	8.5	20	8
140	8	36	20	8.5	20	8
230	10	45	25	10	25	10
340	12	54	30	11	30	12
490	14	63	35	13	35	14
700	16	63	35	13	35	14
1200	20	72	40	16	40	16
1500	22	81	45	18	45	18
1800	24	90	50	20	50	20
2500	27	90	50	20	50	20
3200	30	108	65	25	60	24
4300	33	108	65	25	60	24
4600	36	126	75	30	70	28
6100	39	126	75	30	70	28
6300	42	144	85	35	80	32
8000	45	144	85	35	80	32
8600	48	166	100	40	90	38

Sizes marked * are additional and proportional to the specification

Bow Nuts - Metric Coarse Thread

SWL (kgs)	A (mm)	B (mm)	C (mm)	D (mm)	E (mm)	F (mm)	G (mm)
230	8	10	32	16	25	64	16
360	10	10	32	16	25	64	16
530	12	12	38	18	30	73	17
1010	16	12	38	18	30	73	17
1580	20	14	45	25	40	102	25
2280	24	17	50	28	50	124	29
3650	30	26	70	38	75	149	29
5340	36	26	70	38	75	149	29

Other thread sizes are also available.

Eyebolts – Stainless Steel

Stainless Steel Eyebolts – Tested & Certified on request

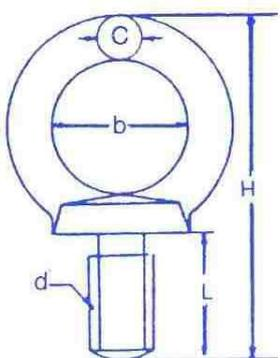
	d (mm)	C (mm)	b (mm)	H (mm)	L (mm)	Weight (kg)
	6	8	20	49	13	0.060
	8	8	20	49	13	0.060
	10	10	25	62	17	0.103
	12	12	30	74.5	20.5	0.177
	16	14	35	90	27	0.280
	20	16	40	102	30	0.424
	24	20	50	126	36	0.834

Eyenuts – Stainless Steel

Stainless Steel Eyenuts

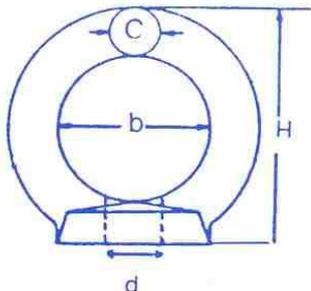
	d (mm)	C (mm)	b (mm)	H (mm)	Weight (kg)
	6	8	20	36	0.052
	8	8	20	36	0.052
	10	10	25	45	0.094
	12	12	30	53	0.160
	16	14	35	62	0.240
	20	16	40	71	0.352
	24	20	50	90	0.706

Eyebolts – Stainless Steel

Stainless Steel Eyebolts with Nut and Washer

	DIA (mm)	F (mm)	A (mm)	B (mm)	L (mm)	Weight (kg)
	6	5	16	26	80	0.03
	8	6	19	31	100	0.07
	10	8	25	41	100	0.13
	12	10	27	47	120	0.24

Starpoint Eyebolts and Eyenuts



Metric Coarse Thread

Thread Size (mm)	Capacity 1 leg at 0° (tonnes)	Capacity 1 leg at 90° (tonnes)	Capacity 2 leg at 0° (tonnes)	Capacity 2 leg at 90° (tonnes)	Capacity 2 leg at 0-45° (tonnes)	Capacity 2 leg 45-60° (tonnes)	Capacity 3 + 4 leg 0-45° (tonnes)	Capacity 3 + 4 leg 45-60° (tonnes)
Method Of Lift								
M6	0.5	0.1	1	0.2	0.14	0.1	0.21	0.15
M8	1	0.3	2	0.6	0.42	0.3	0.63	0.45
M10	1	0.4	2	0.8	0.56	0.4	0.8	0.6
M12	2	0.7	4	1.5	1	0.7	1.5	1.1
M16	4	1.5	8	3	2.1	1.5	3.1	2.2
M20	6	2.3	12	4.6	3.2	2.3	4.8	3.4
M24	8	3.2	16	6.4	4.5	3.2	6.7	4.8
M30	12	4.5	24	9	6.3	4.5	9.4	6.7
M36	16	7	32	14	9.8	7	14.7	10.5
M42	24	9	48	18	12.6	9	18.9	13.5
M48	32	12	64	24	16.8	12	25	18

Imperial Thread

Thread Size (inches)	Capacity 1 leg at 0° (tonnes)	Capacity 1 leg at 90° (tonnes)	Capacity 2 leg at 0° (tonnes)	Capacity 2 leg at 90° (tonnes)	Capacity 2 leg at 0-45° (tonnes)	Capacity 2 leg 45-60° (tonnes)	Capacity 3 + 4 leg 0-45° (tonnes)	Capacity 3 + 4 leg 45-60° (tonnes)
Method Of Lift								
1/4	0.5	0.1	1	0.2	0.14	0.1	0.21	0.15
3/8	1	0.4	2	0.8	0.56	0.4	0.84	0.6
1/2	2	0.75	4	1.5	1.05	0.75	1.575	1.125
5/8	4	1.5	8	3	2.1	1.5	3.15	2.25
3/4	6	2.3	12	4.6	3.22	2.3	4.83	3.45
7/8	6	2.3	12	4.6	3.22	2.3	4.83	3.45
1	8	3.2	16	6.4	4.48	3.2	6.72	4.8
1. 1/4	12	4.5	24	9	6.3	4.5	9.45	6.75
1. 1/2	16	7	32	14	9.8	7	14.7	10.5
1. 3/4	24	9	48	18	12.6	9	18.9	13.5
2	32	12	64	24	16.8	12	25.2	18

Rotating Lifting Points

(also known as Swivel Hoist Rings)

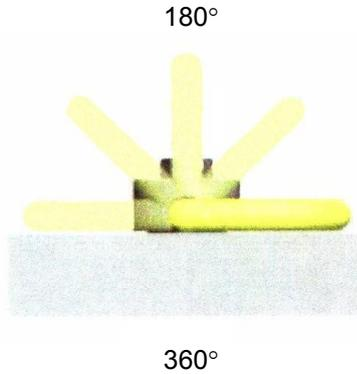
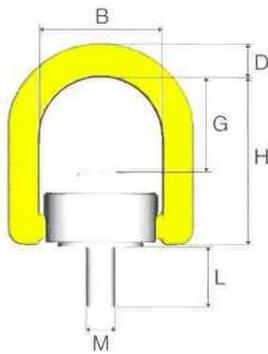

Code	WLL (kg)	L1/L2 (mm)	M (mm)	B (mm)	D (mm)	G (mm)	H (mm)	Weight (kg)
RPL M8-8+	400	15/26	M8	42	12	35	60	0.3
RPL M10-8+	700	20/31	M10	42	12	34	60	0.3
RPL M12-8+	1200	19/40	M12	57	19	46.5	85	0.9
RPL M16-8+	2000	24/50	M16	57	19	44	85	0.9
RPL M20-8+	2800	32/67	M20	83	28	56	111	2.8
RPL M24-8+	4600	37/77	M24	83	28	53	111	2.8
RPL M30-8+	6000	49.5	M30	114	34	69.5	144	7.0
RPL M36-8+	8000	61.0	M36	114	34	65.5	144	7.3
RPL M42-8+	14000	65.5	M42	149	40.4	90	185	14.0
RPL M48-8+	16000	75.5	M48	149	40.4	86	185	14.9

Straight pull gives a higher WLL, see table below.

Longer bolt can be supplied on special request.

Available in UNC thread; 5/16", 3/8", 1/2", 5/8", 3/4", 7/8", 1", 1.1/4", 1.1/2", 1.3/4", 2"

Working Load Limits (tonnes)

Symmetric Load (tonnes)	1		2		Z symmetric		3 & 4 symmetric	
	0°	90°	0°	90°	0-45°	45-60°	0-45°	45-60°
RPL - M8 x 1.25	0.8	0.4	1.6	0.8	0.5	0.4	0.8	0.6
RPL 5/16"-18 UNC	0.8	0.4	1.6	0.8	0.5	0.4	0.8	0.6
RPL - M10 x 1.5	1.2	0.7	2.4	1.4	0.9	0.7	1.4	1.0
RPL 3/8"-16 UNC	1.2	0.65	2.4	1.3	0.9	0.6	1.3	0.9
RPL - M12 x 1.75	2.0	1.2	4.0	2.4	1.6	1.2	2.5	1.8
RPL 1/2"-13 UNC	2.0	1.2	4.0	2.4	1.6	1.2	2.5	1.8
RPL - M16 x 2	3.2	2.0	6.4	4.0	2.8	2.0	4.2	3.0
RPL 5/8"-11 UNC	3.2	2.0	6.4	4.0	2.8	2.0	4.2	3.0
RPL - M20 x 2.5	5.6	2.8	11.2	5.6	3.9	2.8	5.8	4.2
RPL 3/4"-10 UNC	5.0	2.5	10.0	5.0	3.5	2.5	5.2	3.7
RPL 7/8"-9 UNC	5.6	2.8	11.2	5.6	3.9	2.8	5.8	4.2
RPL - M24 x 3	9.2	4.6	18.4	9.2	6.4	4.6	9.6	6.9
RPL 1"-8 UNC	9.2	4.6	18.4	9.2	6.4	4.6	9.6	6.9
RPL - M30 x 3.5	12.0	6.0	24.0	12.0	8.4	6.0	12.6	9.0
RPL 1 1/4"-7 UNC	12.0	6.0	24.0	12.0	8.4	6.0	12.6	9.0
RPL - M36 x 4	14.0	8.0	28.0	16.0	11.2	8.0	16.8	12.0
RPL 1 1/2"-6 UNC	14.0	8.0	28.0	16.0	11.2	8.0	16.8	12.0
RPL - M42 x 4.5	16.0	14.0	32.0	28.0	19.6	14.0	29.4	21.0
RPL 1 3/4"-5 UNC	16.0	14.0	32.0	28.0	19.6	14.0	29.4	21.0
RPL - M48 x 5	20.0	16.0	40.0	32.0	22.4	16.0	33.6	24.0
RPL 2"-4.5 UNC	20.0	16.0	40.0	32.0	22.4	16.0	33.6	24.0

RPL – Rotating Lifting Point, Grade 10

The patented new design of the RPL makes it suitable also in applications where a conventional Lifting point would not be fully adequate. Intended to be used as a Lifting point, Lashing point or Towing attachment.

- Dismountable open D-ring. Enables assembly of roundsling, master link, link or hook directly onto RPL.
- Hexagon-headed screw for easy assembly/disassembly by means of an ordinary wrench.
- RPL can rotate 360° and articulate 180°.
- Forged in Grade 10 material permits higher WLL than Grade 8 and DIN 580 eyebolts.

Specialist Lifting Eye Range

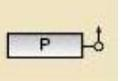
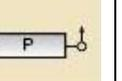
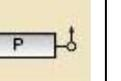
Type	Swivel Key Eye Point		Swivel Hoist Ring Type 231		Lifting Point		Swivel Hoist Ring Type 203	
								
Thread Size (mm)	Capacity 1 leg at 90° (tonnes)	Capacity 1 leg at 0° (tonnes)	Capacity 1 leg at 90° (tonnes)	Capacity 1 leg at 0° (tonnes)	Capacity 1 leg at 90° (tonnes)	Capacity 1 leg at 0° (tonnes)	Capacity 1 leg at 90° (tonnes)	Capacity 1 leg at 0° (tonnes)
Method Of Lift								
M8	-	-	0.50	0.50	0.3	0.3	0.50	0.50
M10	0.40	1.00	0.70	0.70	0.63	0.63	0.55	0.55
M12	0.75	2.00	1.00	1.00	1.00	1.00	1.30	1.30
M14	-	-	1.50	1.50	1.20	1.20	-	-
M16	1.50	4.00	2.00	2.00	1.50	1.50	2.40	2.40
M18	-	-	2.50	2.50	2.00	2.00	-	-
M20	2.30	6.00	3.00	3.00	2.50	2.50	2.70	2.70
M24	3.20	8.00	5.00	5.00	4.00	4.00	5.25	5.25
M27	-	-	5.60	5.60	4.00	4.00	-	-
M30	4.50	12.00	7.80	7.80	5.00	5.00	8.75	8.75
M36	7.00	16.00	12.50	12.50	7.00	7.00	13.75	13.75
M42	9.00	24.00	15.60	15.60	10.00	10.00	15.60	15.60
M48	12.00	32.00	20.00	20.00	20.00	20.00	16.90	16.90
M56	-	-	22.00	22.00	-	-	-	-
M64	-	-	22.50	22.50	-	-	-	-

(UNC)	(lbs)	(lbs)	(lbs)	(lbs)	(lbs)	(lbs)	(lbs)	(lbs)
5/16"	-	-	-	-	-	-	800	800
3/8"	-	-	-	-	-	-	1000	1000
1/2"	-	-	-	-	2200	2200	2500	2500
5/8"	-	-	-	-	3300	3300	4000	4000
3/4"	-	-	-	-	5500	5500	5000	5000
7/8"	-	-	-	-	5500	5500	8000	8000
1"	-	-	-	-	8800	8800	10000	10000
1. 1/4"	-	-	-	-	11000	11000	15000	15000
1. 1/2"	-	-	-	-	17000	17000	24000	24000
1. 3/4"	-	-	-	-	33000	33000	-	-
2"	-	-	-	-	44000	44000	30000	30000

□ Please contact us for capacities on different slinging methods.

Small Dee and Bow Shackles to BS 3032

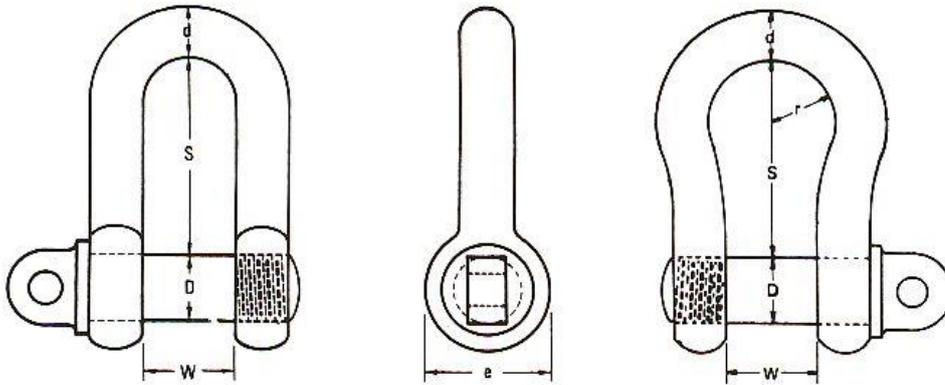

Small Dee Shackles

S.W.L. (tons)	d (inches)	D (inches)	W (inches)	S (inches)	e (inches)
0.30	1/4	3/8	3/8	7/8	3/4
0.60	3/8	1/2	5/8	1.3/8	1
1.00	1/2	5/8	7/8	1.7/8	1.1/4
1.75	5/8	3/4	1	2.1/4	1.1/2
2.50	3/4	7/8	1.1/4	2.3/4	1.3/4
3.50	7/8	1	1.3/8	3.1/4	2
4.50	1	1.1/8	1.1/2	3.5/8	2.1/4
5.50	1.1/8	1.1/4	1.3/4	4.1/8	2.1/2
7.00	1.1/4	1.3/8	1.7/8	4.1/2	2.3/4
8.00	1.3/8	1.1/2	2.1/8	5	3
10.75	1.1/2	1.3/4	2.3/8	5.1/2	3.1/2
13.00	1.5/8	1.7/8	2.1/2	5.7/8	3.3/4
14.75	1.3/4	2	2.3/4	6.3/8	4
16.75	1.7/8	2.1/8	2.7/8	6.3/4	4.1/4
19.00	2	2.1/4	3	7.1/4	4.1/2

Small Bow Shackles

S.W.L. (tons)	d (inches)	D (inches)	W (inches)	S (inches)	e (inches)
0.50	3/8	1/2	5/8	1.1/2	1
1.00	1/2	5/8	7/8	2	1.1/4
1.50	5/8	3/4	1.1/8	2.1/2	1.1/2
2.00	3/4	7/8	1.3/8	3	1.3/4
3.00	7/8	1	1.1/2	3.1/2	2
4.00	1	1.1/8	1.3/4	4	2.1/4
5.00	1.1/8	1.1/4	2	4.1/2	2.1/2
6.25	1.1/4	1.3/8	2.1/4	5	2.3/4
7.50	1.3/8	1.1/2	2.3/8	5.1/2	3
9.25	1.1/2	1.3/4	2.5/8	6	3.1/2
10.50	1.5/8	1.7/8	2.7/8	6.1/2	3.3/4
12.50	1.3/4	2	3.1/8	7	4

Available with a screw pin or a nut, bolt and split pin.

Large Dee and Bow Shackles to BS 3032

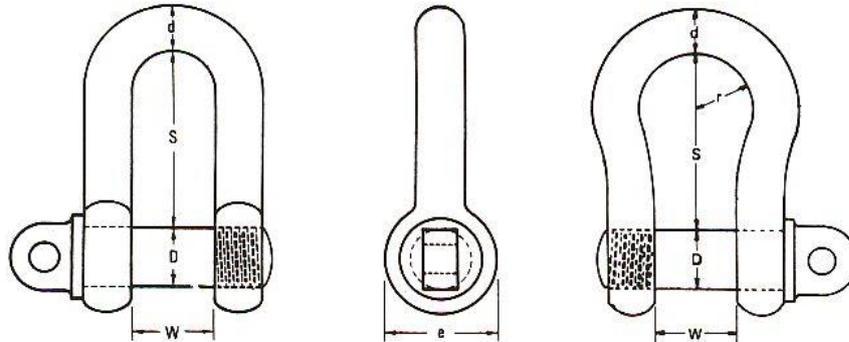

Large Dee Shackles

S.W.L. (tons)	d (inches)	D (inches)	W (inches)	S (inches)	e (inches)
0.25	1/4	3/8	1/2	1	3/4
0.50	3/8	1/2	3/4	1.1/2	1
0.75	1/2	5/8	1.1/8	2.1/8	1.1/4
1.50	5/8	3/4	1.1/4	2.1/2	1.1/2
2.00	3/4	7/8	1.1/2	2.7/8	1.3/4
3.00	7/8	1	1.3/4	3.1/4	2
3.75	1	1.1/8	2	3.3/4	2.1/4
5.00	1.1/8	1.1/4	2.1/8	4.1/8	2.1/2
6.00	1.1/4	1.3/8	2.3/8	4.1/2	2.3/4
7.00	1.3/8	1.1/2	2.5/8	5	3
9.50	1.1/2	1.3/4	2.3/4	5.3/8	3.1/2
11.25	1.5/8	1.7/8	3	5.3/4	3.3/4
13.00	1.3/4	2	3.1/4	6.1/8	4
14.25	1.7/8	2.1/8	3.5/8	7	4.1/4
16.25	2	2.1/4	3.7/8	7.3/8	4.1/2
18.00	2.1/8	2.3/8	4.1/8	7.3/4	4.3/4
20.00	2.1/4	2.1/2	4.1/4	8.1/4	5

Large Bow Shackles

S.W.L. (tons)	d (inches)	D (inches)	W (inches)	S (inches)	e (inches)
0.15	1/4	3/8	1/2	1.1/8	3/4
0.45	3/8	1/2	5/8	1.5/8	1
0.75	1/2	5/8	7/8	2.1/8	1.1/4
1.25	5/8	3/4	1.1/8	2.3/4	1.1/2
2.00	3/4	7/8	1.3/8	3.3/8	1.3/4
2.75	7/8	1	1.5/8	3.7/8	2
3.75	1	1.1/8	1.3/4	4.1/4	2.1/4
4.75	1.1/8	1.1/4	2	4.7/8	2.1/2
5.75	1.1/4	1.3/8	2.1/4	5.3/8	2.3/4
7.25	1.3/8	1.1/2	2.1/2	6	3
8.50	1.1/2	1.3/4	2.3/4	6.5/8	3.1/2
9.50	1.5/8	1.7/8	3	7.3/8	3.3/4
11.50	1.3/4	2	3.3/8	8.1/8	4
13.00	1.7/8	2.1/8	3.5/8	8.3/4	4.1/4
15.00	2	2.1/4	3.7/8	9.3/8	4.1/2

Available with a screw pin or a nut, bolt and split pin.

Alloy Dee and Bow Shackles to EN 13889

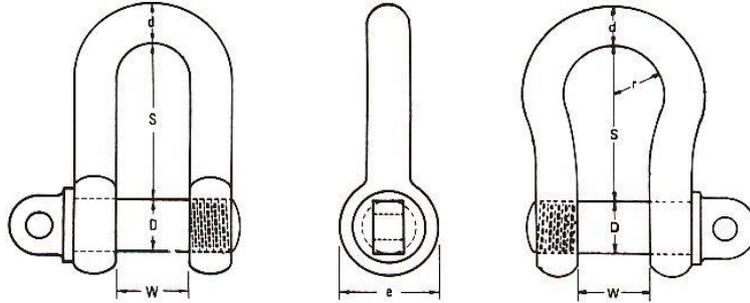

Dee Shackles

WLL Tonnes	d mm	D mm	W mm	S mm	e mm
0.50	6	8	12	22	16
0.75	8	10	13.5	26	19
1.00	10	11	17	32	23
1.50	11	13	19	37	27
2.00	13	16	20	41	30
3.25	16	19	27	51	38
4.75	19	22	32	60	46
6.50	22	25	36	71	53
8.50	25	28	43	81	61
9.50	28	32	46	90	68
12.00	32	35	51	100	76
13.50	35	38	57	111	84
17.00	38	42	60	122	92
25.00	45	50	73	146	106
35.00	50	57	83	171	119
55.00	65	70	105	203	145

Bow Shackles

WLL Tonnes	d mm	D mm	W mm	S mm	e mm
0.33	5	6	9.5	22	14
0.50	6	8	12	29	16
0.75	8	10	13.5	31	19
1.00	10	11	17	37	23
1.50	11	13	19	43	27
2.00	13	16	20	48	30
3.25	16	19	27	60	38
4.75	19	22	32	71	46
6.50	22	25	36	84	53
8.50	25	28	43	95	61
9.50	28	32	46	108	63
12.00	32	35	51	119	76
13.50	35	38	57	133	84
17.00	38	42	60	146	92
25.00	45	50	73	177	106
35.00	50	57	83	197	119
55.00	65	70	105	260	145

Available with a screw pin or a nut, bolt and split pin.

Shackles – Stainless Steel

Stainless Steel High Tensile Bow Shackles

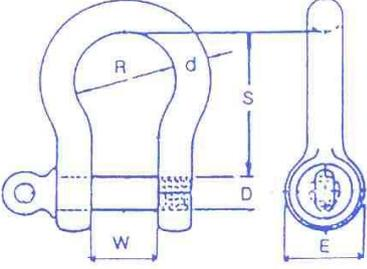
	WLL (tonnes)	d (mm)	D (mm)	W (mm)	S (mm)	R (mm)	Weight (kg)
	0.8	8	10	16	32	24	0.09
1.5	10	12.7	20	40	30	0.16	
2.5	12.7	16	25	50	38	0.37	
4.0	16	19	32	64	48	0.58	
5.5	19	22.2	38	76	57	1.05	
7.5	22.2	25.4	44	88	66	2.00	
9.0	25.4	28.6	51	102	76	3.05	

Stainless Steel High Tensile Dee Shackles

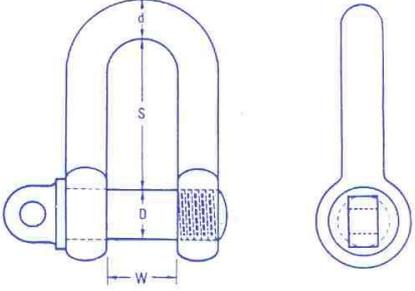
	SWL (tonne)	d (mm)	D (mm)	W (mm)	S (mm)	Weight (kg)
	1	8	10	16	32	0.1
2	10	12.7	20	40	0.2	
3	12.7	16	25	50	0.4	
5	16	19	32	64	0.7	
7	19	22	38	76	0.9	
9	22.2	25	44	88	1.4	
11	25.4	28.6	51	102	2.2	
13	28.6	31.8	57	114	2.9	
15	31.8	34.9	64	128	4.1	
18	34.9	38	70	140	6.2	

Stainless Steel Long Dee Shackles

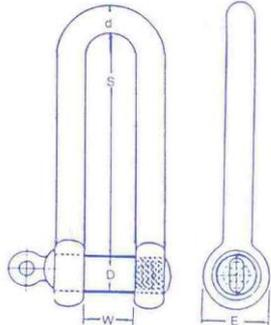
	d (mm)	D (mm)	W (mm)	E (mm)	S (mm)	Weight (kg)
	4	4	8	8	30	0.01
5	5	10	10	37	0.02	
6	6	12	12	45	0.04	
8	8	16	16	60	0.09	
10	10	20	20	75	0.20	
12	12	24	24	90	0.32	

Stainless Steel Bow Shackles (Dee shackles also available)

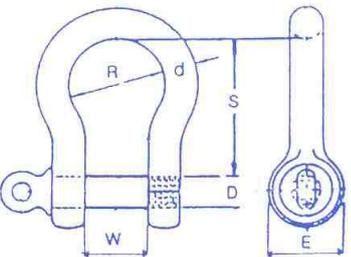
	d (mm)	D (mm)	W (mm)	R (mm)	E (mm)	S (mm)	Weight (kg)
	5	5	10	17	10	22	1.7
6	6	12	21	12	27	2.8	
8	8	16	28	16	32	6.4	
10	10	20	34	20	46	13.5	
12	12	24	42	24	55	22.9	
16	16	32	53	32	65	47.2	
20	20	40	65	40	76	108.3	

Carbine Hooks *(also available in Stainless Steel)*

Carbine Hooks Zinc Plated

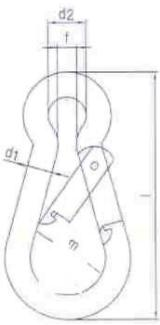
	Size d1 (mm)	l (mm)	d2 (mm)	f (mm)	m (mm)	Weight/100 (kg)
	4	40	7	5	14	1.0
5	50	8	7	16	1.5	
6	60	9	7	18	2.5	
7	70	10	9	22	4.0	
8	80	12	11	24	6.0	
9	90	12	11	26	9.0	
10	100	15	12	30	12.5	
11	120	18	14	36	18.0	
12	140	20	16	40	25.5	
13	160	22	20	44	33.5	
14	180	28	20	48	45.0	
15	200	29	22	52	57.0	

Carbine Hooks with Eyelet

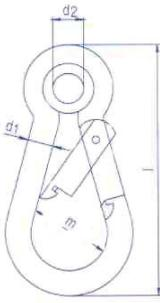
	Size d1 (mm)	l (mm)	d2 (mm)	m (mm)	Weight/100 (kg)
	4	40	4	14	1.1
5	50	5	16	1.6	
6	60	6	18	2.6	
7	70	7	22	4.4	
8	80	10	24	6.4	
9	90	12	26	9.3	
10	100	13	30	12.7	
11	120	13	36	19.5	
12	140	15	40	26.6	
13	160	17	44	35.0	

Quick Links *(also available in Stainless Steel)*

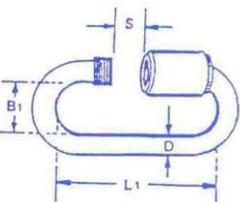
	D Ø (mm)	L1 (mm)	B1 (mm)	S (mm)	Weight/100 (kg)
	3.5	29	10	5	0.9
4	32	11	5	1.3	
5	39	13	6	2.0	
6	46	14	7	3.3	
7	51	16	8	5.3	
8	59	17	10	7.5	
9	64	17	11	10.3	
10	70	20	12	13.0	
12	83	23	14	25.0	

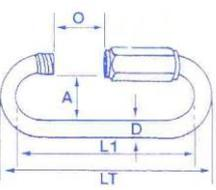
	D Ø (mm)	L1 (mm)	LT (mm)	A (mm)	O (mm)	Breaking Load (kg)	Weight/100 (kg)
	3.5	39	46	10	10	240	0.9
5	52	62	14	13	540	2.5	
6	58	70	16	14	750	4.2	
8	73	89	19	17	1500	9.4	
10	88	108	22	20	2400	17.5	
12	102	126	25	23	3600	28.2	

Popular Assemblies



Unusual Slings Conditions

Recommended Load Factors for unusual slinging conditions, normally applied to W.L.L. of a single sling.

Temperature Loadings: Applicable to chain temperature.

- 40° C to + 200° C	+ 200° C to + 300° C	+ 300° C to + 400° C
1	0.9	0.75

Edge Loadings: *Applicable to load lifting and load lashing.*

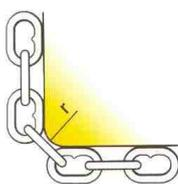

r = more than 2 x chain size
1

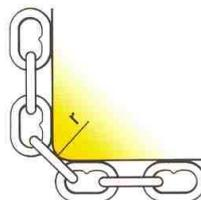

r = more than chain size
0.7

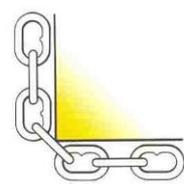

NOT RECOMMENDED
WITHOUT CORNER PROTECTION

Working Load Limits – Grade 80

Uniform Load Method of Rating BS EN 818-4

All general purpose slings should be rated by the uniform load method as shown in the table

Lifting Method						
	Single Leg 0° (tonnes)	Endless 0° (tonnes)	2-Leg 0-45° (tonnes)	2-Leg 45-60° (tonnes)	3 or 4-Leg 0-45° (tonnes)	3 or 4-Leg 45-60° (tonnes)
7	1.5	2.5	2.1	1.5	3.1	2.2
8	2.0	3.1	2.8	2.0	4.2	3.0
10	3.15	5.0	4.25	3.15	6.7	4.75
13	5.3	8.5	7.5	5.3	11.2	8.0
16	8.0	12.5	11.2	8.0	17.0	11.8
20	12.5	20.0	17.0	12.5	26.5	19.0
22	15.0	23.6	21.2	15.0	31.5	22.4
26	21.2	33.5	30.0	21.2	45.0	31.5
32	31.5	50.0	45.0	31.5	67.0	47.5

Unusual Slinging Methods

Recommended Load Factors for unusual slinging methods, normally applied to W.L.L. of a single sling.

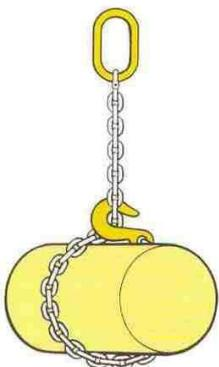

0.8

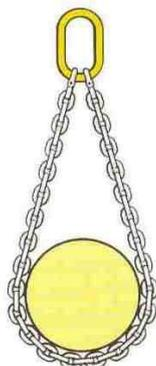

2

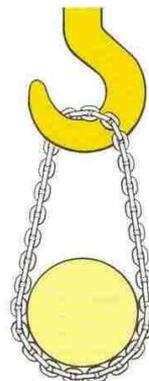

1.3

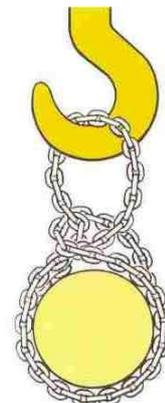

1.6

Components

Grade 'T' (8) Chain BS EN 818-2

Properties:

Working Load Limit (W.L.L.) is the maximum load which chain or components are designed to sustain in lifting use. The mean stress at this load is 200n/mm² (MPa) and is based on a factor of safety of 4:1.

Manufacturing Proof Force (M.P.F.) is the force to which during manufacture chain or components are subjected. The mean stress at this load is 500n/mm² (MPa), which is 2.5 times the working load limit.

Minimum Breaking Load (M.B.L.) is the minimum force which chain or components must withstand before failure. The mean stress at this load is 800n/mm² (MPa). The minimum elongation before failure is 20%.

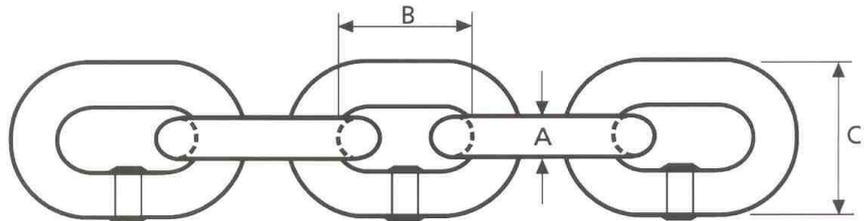

A mm	B mm	C mm	WLL Tonnes	Kgs per metre
7	21	25.9	1.5	1.1
8	24	29.6	2.0	1.5
10	30	37.0	3.15	2.2
13	39	48.1	5.3	3.8
16	48	59.2	8.0	5.8
20	60	74.0	12.5	9.1
22	66	81.4	15.0	11.0
26	78	96.2	21.2	15.3
32	96	118.0	31.5	23.2

Master Links

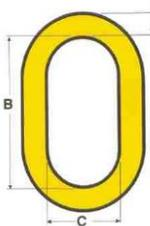

Chain ø mm	Chain ø mm		A mm	B mm	C mm
	Single	Double			
6,7&8	6		13	110	60
10	7&8		16	140	70
13	10		20	160	90
16	13		25.5	200	110
20	16		32	270	140
22	20		36	282	153
26	22		40	280	155
32	26		50	360	190
36	32		60	410	220

Sub Assemblies

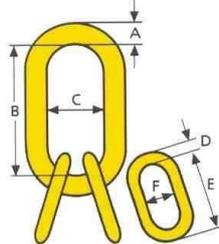

Chain ø mm	A mm	B mm	C mm	D mm	E mm	F mm
6	16	140	70	13	110	60
7&8	20	160	90	13	140	70
10	26	195	110	16	160	90
13	32	240	140	22	200	110
16	40	280	155	28	270	140
20	45	320	175	32	280	155
22	50	350	190	40	140	80
26	60	410	220	45	165	90
32	70	450	250	50	195	100

Reevable Link – Grade 100 only

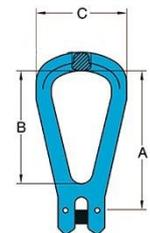

Chain ø mm	A mm	B mm	C mm
7/8	99	80	65
10	125	100	80
13	168	136	108
16	198	158	124

Component Connector

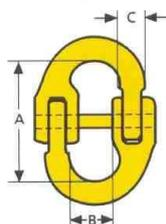

Chain Size mm	A mm	B mm	C mm
7/8	57	18	9
10	68	25	11
13	91	30	16
16	100	36	19
20	122	42	22
22	152	49	24
26	162	55	30
32	202	69	36

Shortening Clutch

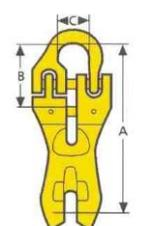

Chain ø mm	A mm	B mm	C mm
7/8	128	58	16
10	154	67	20
13	203	88	26
16	248	105	32

Clevis Shortening Clutch

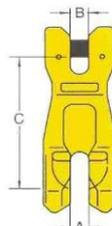

Chain ø mm	A mm	B mm	C mm
7/8	8	9	62
10	12	12	87
13	16	17	115
16	20	20	143
20	21	23	152

Components

Clevis Grab Hook

Chain Ø mm	A mm	B mm	C mm	D mm
7/8	10	9	55	30
10	13	12	77	41
13	16	15	97	53
16	20	17	102	58
20	23	23	124	98

Eye Grab Hook

Chain Ø mm	A mm	B mm	C mm	D mm	E mm
7/8	10	15	9	60	30
10	13	20	13	84	41
13	16	25	15	102	52
16	20	30	20	114	57
20	23	36	24	132	73
22	26	38	26	165	70
26	29	41	32	187	100
32	37	57	40	230	90

Clevis Sling Hook

Chain Ø mm	A mm	B mm	C mm
7/8	98	22	27
10	121	29	34
13	147	37	44
16	166	42	48
20	200	50	56

Eye Sling Hook

Chain Ø mm	A mm	B mm	C mm	D mm	E mm
7/8	98	28	25	11	23
10	121	36	32	14	31
13	152	40	40	18	38
16	184	44	50	22	47
20	218	45	60	26	48
22	244	73	50	31	62
26	279	77	64	35	80
32	352	114	88	40	86

Clevis C Hook

Chain Ø mm	A mm	B mm	C mm
7/8	80	18	22
10	105	24	26
13	138	32	34
16	170	37	45

Foundry Hook – Grade 100 only

Chain Ø mm	A mm	H mm	K mm	P mm	T mm
7/8	9	27	133	62	19
10	11	32	163	74	23
13	14	39	200	88	32
16	18	47	239	98	41
20	21	62	305	113	46

Clevis Self Locking Hook

Chain Ø mm	A mm	B mm	C mm
7/8	119	34	24
10	143	44	30
13	179	52	39
16	212	60	49
20	243	90	62
22	273	80	63

Eye Self Locking Hook

Chain Ø mm	A mm	B mm	C mm	D mm	E mm
7/8	136	34	25	11	24
10	167	44	32	13	30
13	207	52	40	16	39
16	252	60	52	21	49
20	282	90	64	23	62
22	319	80	70	24	63
26	343	99	80	25	69
28	401	120	90	28	81

Swivel Self Locking Hook – Ball Bearing

WLL tonne	Chain Ø mm	A mm	B mm	D mm	H mm	K mm	P mm	T mm	Mass kg
1.12	7/8	36	29	14	24	186	34	20	1.2
2.0	10	40	34	16	30	220	44	26	2.0
3.15	13	46	43	22	39	267	52	30	4.2
5.3	16	60	50	24	49	328	60	36	7.3
8.0	20	75	82	26	62	388	90	48	11.4
12.5	22	97	95	33	63	457	80	49	18.1
15.0	26	123	115	42	69	535	99	56	29.5

Components

Swivel Sling Hook – Ball Bearing

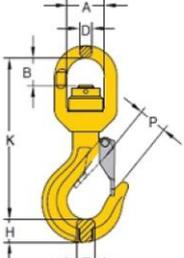

WLL tonne	Chain Ø mm	K mm	P mm	B mm	A mm	D mm	T mm	H mm	Mass kg
2.0	7/8	155	26	27	36	12	18	22	0.9
3.15	10	189	36	37	41	16	23	29	1.6
5.3	13	233	42	40	46	21	28	35	3.2
8.0	16	280	50	50	60	22	35	44	5.3
12.5	20	356	56	82	74	25	49	65	9.2

Clevis Shackle

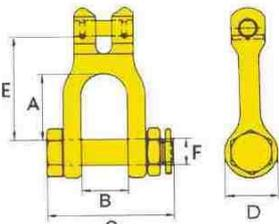

Chain Ø mm	A mm	B mm	C mm	D mm	E mm	F mm	Mass kg
7/8	35	33	79	34	59	16	0.4
10	48	37	93	40	78	20	0.8
13	64	49	118	44	98	22	1.4
16	69	60	141	54	112	28	2.5

Weld On Hook

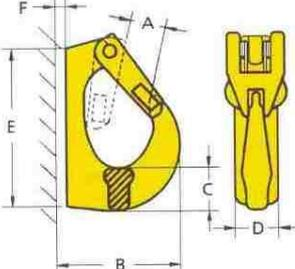

WLL tonne	A mm	B mm	C mm	D mm	E mm	F mm	Mass kg
1.0	18	70	27	25	95	7	1.3
2.0	25	85	30	30	115	8	2.2
3.0	28	107	30	35	133	9	3.1
4.0	28	114	38	42	142	10	4.4
5.0	30	135	47	45	167	12	6.6
8.0	32	137	52	50	176	12	8.4
10.0	44	170	56	56	222	13	13.9

Weld On Lifting Point

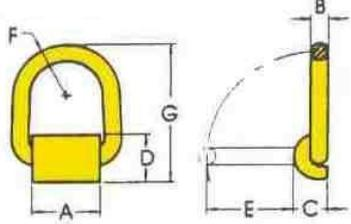

WLL tonne	A mm	B mm	C mm	D mm	E mm	F mm	G mm	Mass kg
1.0	50	14.2	27	38	55	24	105	1.1
3.0	58	17.2	34	48	60	29	112	1.8
5.0	64	22.5	43	61	74	33	154	4.0
8.0	61	27.8	54	73	82	34	169	5.7
10.0	75	30.8	54	73	103	41	191	6.8
15.0	91	37.5	70	93	123	50	234	14.3

Barrel Hook

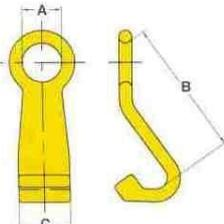

WLL t	Chain Ø mm	A mm	B mm	C mm
1.6	7/8	38	133	50

Skip Hook

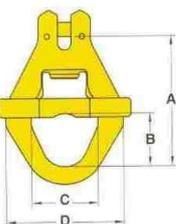

WLL t	Chain Ø mm	A mm	B mm	C mm	D mm
5.3	13	141	57	65	125

Working Load Limits – Grade 100

Uniform Load Method of Rating BS EN 818-4

All general purpose slings should be rated by the uniform load method as shown in the table

Lifting Method	Diagram 1: Single Leg		Diagram 2: 2-Leg		Diagram 3: 3 or 4-Leg		
	Chain Ø (mm)	Single Leg 0° (tonnes)	Endless 0° (tonnes)	2-Leg 0-45° (tonnes)	2-Leg 45-60° (tonnes)	3 or 4-Leg 0-45° (tonnes)	3 or 4-Leg 45-60° (tonnes)
	6	1.4	2.2	2.0	1.4	2.9	2.1
	8	2.5	4.0	3.5	2.5	5.3	3.8
	10	4.0	6.4	5.6	4.0	8.4	6.0
	13	6.7	10.6	9.5	6.7	14.0	10.0
	16	10.0	16.0	14.0	10.0	21.0	15.0
	20	16.0	25.6	22.4	16.0	33.6	24.0
	22	19.0	30.4	26.5	19.0	40.0	28.0

Unusual Slinging Methods

Recommended Load Factors for unusual slinging methods, normally applied to W.L.L. of a single sling.

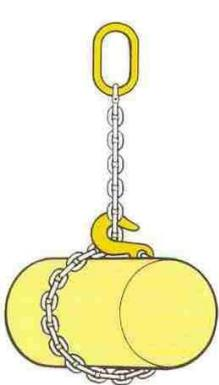

0.8

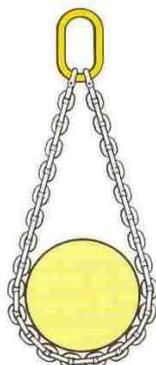

2

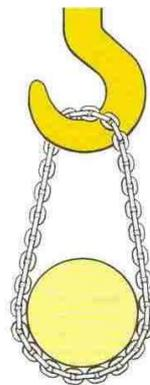

1.3

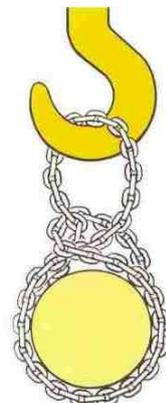

1.6

Components

Grade 'T' (10) Chain BS EN 818-2

Properties:

Working Load Limit (W.L.L.) is the maximum load which chain or components are designed to sustain in lifting use. The mean stress at this load is 200n/mm² (MPa) and is based on a factor of safety of 4:1.

Manufacturing Proof Force (M.P.F.) is the force to which during manufacture chain or components are subjected. The mean stress at this load is 500n/mm² (MPa), which is 2.5 times the working load limit.

Minimum Breaking Load (M.B.L.) is the minimum force which chain or components must withstand before failure. The mean stress at this load is 800n/mm² (MPa). The minimum elongation before failure is 20%.

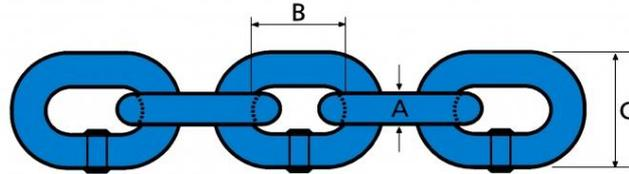

A mm	B mm	C mm	WLL Tonnes	Kgs per metre
6	18	25.9	1.4	0.8
8	24	29.6	2.5	1.5
10	30	37.0	4.0	2.2
13	39	48.1	6.7	3.8
16	48	59.2	10.0	5.8
20	60	74.0	16.0	9.1
22	66	81.4	19.0	11.0

Master Links

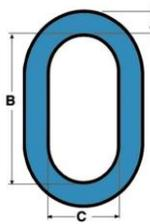

Chain ø mm	Chain ø mm		A mm	B mm	C mm
	Single	Double			
6,7&8	6		13	110	60
10	7&8		16	140	70
13	10		20	160	90
16	13		25.5	200	110
20	16		32	270	140
22	20		36	282	153
26	22		40	280	155

Sub Assemblies

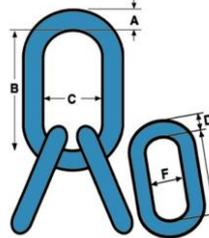

Chain ø mm	A mm	B mm	C mm	D mm	E mm	F mm
6	16	140	70	13	110	60
7&8	20	160	90	16	140	70
10	25.5	200	110	20	160	90
13	32	270	140	26	200	110
16	40	280	155	32	270	140
20	50	350	195	40	280	155

Component Connector

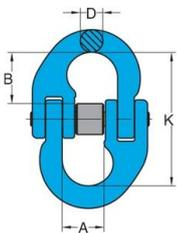

Chain ø mm	K mm	A mm	D mm	B mm
6	45	15	7	18
7/8	59	18	9	25
10	69	25	11	28
13	92	30	16	38
16	101	36	19	41
20	122	42	23	50
22	152	49	24	63

Eye Grab Hook

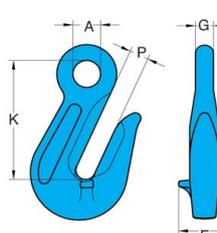

Chain Size mm	P mm	A mm	G mm	K mm	F mm
6	8	13	8	50	26
7/8	10	16	9	62	30
10	13	20	13	82	41
13	17	26	16	107	52
16	21	30	20	132	57
20	23	38	24	147	73
22	26	38	26	165	70

Clevis Sling Hook

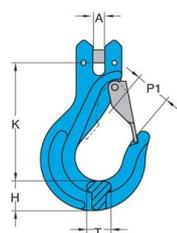

Chain ø mm	A mm	K mm	P1 mm	T mm	H mm
6	6	97	23	15	23
7/8	9	98	18	27	22
10	11	122	24	34	30
13	14	147	30	44	37
16	17	166	39	48	42
20	24	207	48	57	64

Clevis Safety Hook

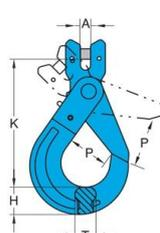

Chain ø mm	A mm	K mm	P mm	T mm	H mm
6	6	93	28	15	19
7/8	9	119	34	20	24
10	11	142	44	26	30
13	14	178	51	30	39
16	18	213	60	36	49
20	21	244	70	53	65

Short Link Chain

Mild steel, commercial quality short link chain. Not to be used for lifting applications!

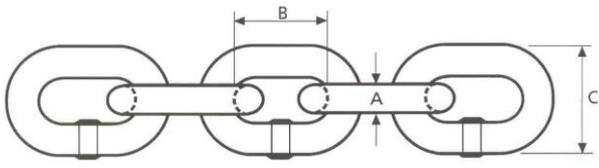
	A (mm)	B (mm)	C (mm)	MBL (kg)	Weight/M (kg)
	5.0	19.0	17.0	1250	0.50
6.0	18.5	20.0	1600	0.78	
8.0	24.0	28.0	3000	1.40	
10.0	30.0	34.0	5000	2.20	
12.0	36.0	46.0	7000	3.20	
16.0	45.0	54.0	12500	5.60	
20.0	60.0	70.0	20000	8.50	

Long Link Chain

Mild steel, commercial quality long link chain. Not to be used for lifting applications!

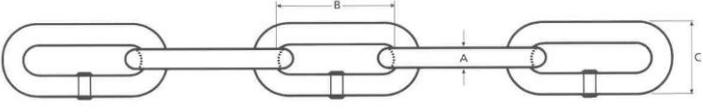
	A (mm)	B (mm)	C (mm)	MBL (mm)	Weight/M (kg)
	5.0	25	21	1000	0.53
7.0	42	28	1900	1.00	
8.0	52	32	2000	1.10	
9.5	50	38	4000	1.65	
13.0	81	48	6000	2.95	
16.0	100	56	10000	4.30	
20.0	100	70	16000	7.20	

Straight Link Chain

Welded mild steel, commercial quality straight link chain. Supplied in reels only.

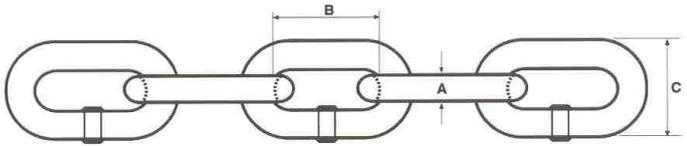
	A (mm)	B (mm)	C (mm)	Weight/Reel (kg)
	2.5	14	12	8.20
2.5	19	12	6.90	
3	16	14	11.40	
3	21	14	10.60	
3	26	14	9.00	
4	19	17	10.40	
4	26	17	9.50	
4	32	17	13.30	
5	28	21	12.50	
6	24	25	15.70	
6	33	25	14.30	
6	42	25	13.60	

Chain – Stainless Steel

Stainless Steel Short Link Chain

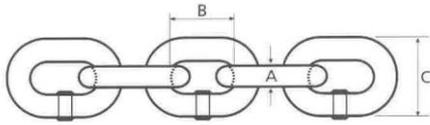

A DIA (mm)	B (mm)	C (mm)	Min. Breaking Load (kg)	Weight/Metre (kg)
3	16	11	340	0.17
4	16	14	800	0.32
5	18.5	17	1250	0.50
6	18.5	20	1600	0.75
8	24	26	3200	1.35
10	28	34	5000	2.25
12	36	40	8000	3.80
16	45	51	12500	5.70

Stainless Steel Long Link Chain

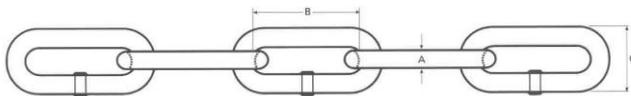

A DIA (mm)	B (mm)	C (mm)	Min. Breaking Load (kg)	Weight/Metre (kg)
2	22	8	180	0.08
3	26	12	340	0.14
4	32	16	800	0.27
5	36	20	1250	0.43
6	42	24	1600	0.63
8	54	32	3200	1.10
10	66	40	5000	1.75
12	76	49	6300	2.99
16	100	64	8000	4.45

Stainless Steel (Grade 5 or 6) Pump Chain – ring pitch 1000 mm

Chain Ø (mm)	WLL (kg)	Ring Size (mm)	Weight / m (kg)
5	630	80 x 50	0.65
7	1370	110 x 60	1.37
9	2340	110 x 60	2.34
13	4120	160 x 90	4.12
16*	5040	160 x 90	5.04
18*	6940	180 x 100	6.94

* Grade 5

Galvanised steel pump chain also available, please contact us for details.

Flat Webbing Slings

Polyester webbing slings have many advantages over conventional chain or steel wire rope slings, particularly where the item to be lifted is in danger of being marked or damaged in the lifting process. The synthetic sling then comes into its own. The slings flexibility and ease of handling are appreciated by those involved in the lifting process and the wide load bearing surface aids safer lifting. Our slings are made from high strength polyester yarn incorporating good shock absorption properties with a high strength to weight ratio. Wear sleeves are available as an optional extra.

Polyester slings are suitable for use in a temperature range from - 40° C to + 100° C and are resistant to moderate strength acids. Do not use in alkali conditions. Seek our advice if exposure to chemicals is likely.

All our slings comply with BSEN 1492 part 1, are colour coded for increased safety with a Safety Factor of 7 : 1.

Sling Types:

1. **Soft Reinforced Eyes Each End**
2. **Metal Eyes Each End**

Simplex

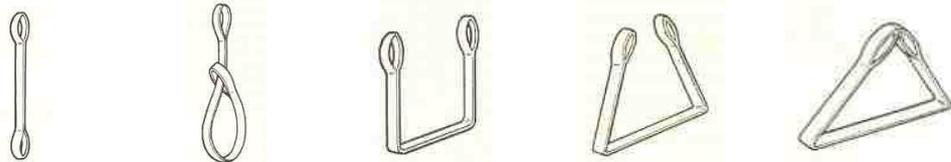

Colour	Width mm	Straight x 1	Choked x 0.8	Basket x 2	45° Basket x 1.8	90° Basket x 1.4
		WLL kgs	WLL kgs	WLL kgs	WLL kgs	WLL kgs
Lime	25	500	400	1000	900	700
Violet	50	1000	800	2000	1800	1400
White	75	1500	1200	3000	2700	2100
Green	100	2000	1600	4000	3600	2800
Yellow	150	3000	2400	6000	5400	4200
Grey	200	4000	3200	8000	7200	5600
Red	250	5000	4000	10000	9000	7000

Duplex

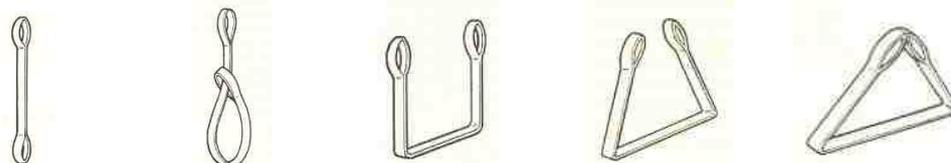

Colour	Width mm	Straight x 1	Choked x 0.8	Basket x 2	45° Basket x 1.8	90° Basket x 1.4
		WLL kgs	WLL kgs	WLL kgs	WLL kgs	WLL kgs
Violet	30	1000	800	2000	1800	1400
Green	60	2000	1600	4000	3600	2800
Yellow	90	3000	2400	6000	5400	4200
Grey	120	4000	3200	8000	7200	5600
Red	150	5000	4000	10000	9000	7000
Brown	180	6000	4800	12000	10800	8400
Blue	240	8000	6400	16000	14400	11200
Orange	300	10000	8000	20000	18000	14000

Other sizes available on request.

Roundslings

All our slings comply with BSEN 1492 part 2, are colour coded for increased safety with a Safety Factor of 7 : 1.

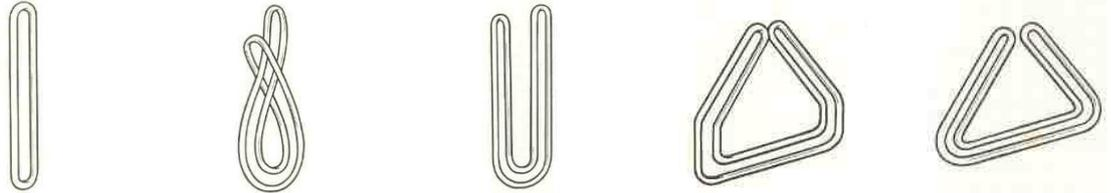

Colour	Straight x 1 WLL kgs	Choke x 0.8 WLL kgs	Basket x 2 WLL kgs	45° Basket x 1.8 WLL kgs	90° Basket x 1.4 WLL kgs
Violet	1000	800	2000	1800	1400
Green	2000	1600	4000	3600	2800
Yellow	3000	2400	6000	5400	4200
Grey	4000	3200	8000	7200	5600
Red	5000	4000	10000	9000	7000
Brown	6000	4800	12000	10800	8400
Blue	8000	6400	16000	14400	11200
Orange	10000	8000	20000	18000	14000
Orange	12000	9600	24000	21600	16800



Joker Hook

Simply thread the roundsling or the eye of a webbing sling to the Joker hook, without using any tools, and now attach the sling to the lifting point of the load. The Joker hook enables single and multi leg slings to be made up using roundslings and flat webbing slings thus reducing sling dead weight and damage to the product to be lifted. The joker hook can also be used to connect two lifting slings together.

Endless Flat Webbing Slings

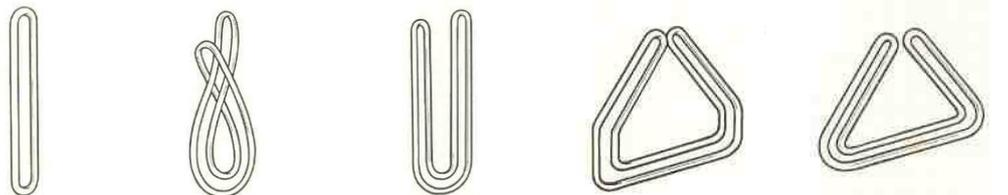

Colour	Width mm	Straight x 1 WLL kgs	Choke x 0.8 WLL kgs	Basket x 2 WLL kgs	45° Basket x 1.8 WLL kgs	90° Basket x 1.4 WLL kgs
Violet	50	1000	800	2000	1800	1400
Green	60	2000	1600	4000	3600	2800
Yellow	90	3000	2400	6000	5400	4200
Grey	120	4000	3200	8000	7200	5600
Red	150	5000	4000	10000	9000	7000
Brown	180	6000	4800	12000	10800	8400
Blue	240	8000	6400	16000	14400	11200
Orange	300	10000	8000	20000	18000	14000

Cargo Restraints

Webbing cargo restraints and chain load binders/tensioners are used extensively throughout industry for safely transporting goods in vans, lorries and low loaders.

Webbing

We offer a range of webbing ratchet cargo restraint assemblies in either a two-part or endless design complying with EN 12195-2:2001. The two-part assembly comprises a short fixed length (usually 300 mm) fitted to the ratchet at one end and with a fitting at the other and a long length (length to order) with a fitting at one end and free the other where it engages with the ratchet.

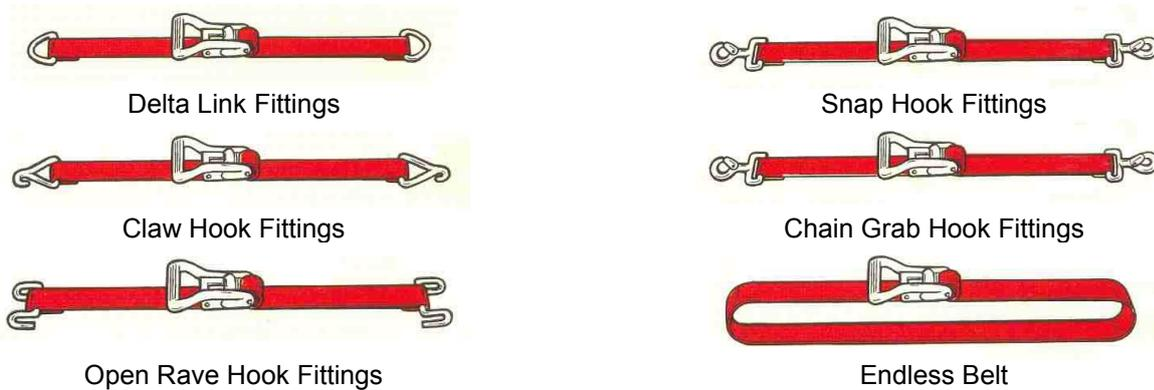

System Breaking Force: 25 mm wide @ 500 kg 50 mm wide @ 5000 kg 75 mm wide @ 10000 kg

Chain

We offer a range of ratchet chain load tensioners manufactured to BSEN 12195-3.



Ratchet Load Tensioner

Chain Size	Capacity (kN)	Mass (kg)
8 mm	40	1.5
10 mm	63	2.2
13 mm	100	3.8
16 mm	160	5.8

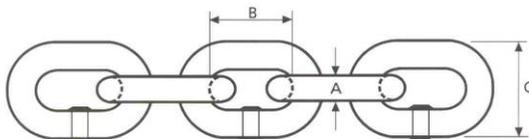

Chain – Grade 'T' (8) BS EN 818-2

A (mm)	B (mm)	C (mm)	Capacity (kN)	Kgs per m
8	24	29.6	40	1.5
10	30	37.0	63	2.2
13	39	48.1	100	3.8
16	48	59.2	160	5.8

Chain Fittings

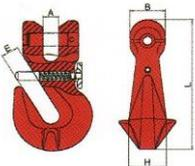

Grade 80 Grab Hook

Chain Size	Capacity (kN)
8 mm	40
10 mm	63
13 mm	100
16 mm	160

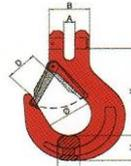

Grade 80 Sling Hook

Chain Size	Capacity (kN)
8 mm	40
10 mm	63
13 mm	100
16 mm	160

Hand Chain Blocks – Spark Resistant also available

Standard Hand Chain Block (larger capacities available)

	Capacity (kgs)	Closed Headroom (hook to hook)	Falls Of Chain	Mass (3 metre lift) (kg)
	250	230 mm	1	4.0
	500	280 mm	1	7.8
	1000	306 mm	1	11.1
	1600	368 mm	1	15.8
	2000	445 mm	1	16.8
	3200	520 mm	2	24.2
	5000	600 mm	2	39.8
	10000	760 mm	4	89.7

New Hand Chain Block (hand chain wheel rotates 360°)

	Capacity (kgs)	Closed Headroom (hook to hook)	Falls Of Chain	Mass (kgs) (3 metre lift)
	500	300 mm	1	9
	1000	335 mm	1	13
	2000	395 mm	1	20
	3000	520 mm	1	29
	5000	654 mm	2	38
	10000	825 mm	3	71
	20000	1300 mm	6	196

A new innovative design with a 360 degree rotating hand chain guide that allows operation of the hoist from any position allowing greater options of working positions for the operator with the hoist operated from the side or even above the load. The hoist can also be used for horizontal pulling.

'Close Headroom' Combined Hand Chain Block & Trolleys

Available with a hand pushed or a hand geared trolley.

	Capacity (kgs)	Closed Headroom (under beam to hook)	Falls Of Chain	Beam Width (mm)		Mass (kgs) (3 metre lift)	
				A	B		
	500	245 mm	1	50 - 180	180 - 300	20/21	24/25
	1000	272 mm	1	58 - 180	180 - 300	27/29	32/33
	2000	323 mm	1	58 - 180	180 - 300	44/46	49/50
	3000	382 mm	1	74 - 180	180 - 300	77/79	82/84
	5000	550 mm	2	98 - 180	180 - 300	125/129	130/134
	10000	784 mm *	3	-	125 - 310	-	175
20000	1084 mm *	6	-	125 - 310	on request		

* available with a hand geared trolley only

Standard Trolleys

Push Travel	Capacity (kgs)	Beam Width (mm)	Beam Width (mm)	Geared Travel	Capacity (kgs)	Beam Width (mm)	Beam Width (mm)
	500	50 - 220	160 - 300		500	50 - 220	160 - 300
	1000	50 - 220	160 - 300		1000	50 - 220	160 - 300
	2000	66 - 220	160 - 300		2000	66 - 220	160 - 300
	3000	74 - 220	180 - 300		3000	74 - 220	180 - 300
	5000	90 - 220	180 - 300		5000	90 - 220	180 - 300
				10000	-	125 - 310	
				20000	-	125 - 310	

Screwlok version also available for easy installation

Lever Hoists – Spark Resistant also available



The versatile Lever Hoist is designed to perform a wide variety of lifting, pulling, tensioning and securing applications. The new generation products incorporate the latest advances in design to provide maximum safety and strength combined with minimum operating effort.

For rapid hook positioning, the load chain can be either 'pulled through' or 'wound through' by means of the hand wheel. The automatic braking function, which fully meets the proposed European Standards, ensures that any load of 20 kg or more will cause the brake to be applied irrespective of the position of the motion selector.

The unit fully complies with the requirements of the EU Machinery Directive and is CE certified.

Operating temperature range of between -40°C to +55°C.

We can supply the length of chain to suit your application.

Lifting Capacity (kg)		800	1600	3200	6300	9000	15000	20000
Number of Falls		1	1	1	2	3	6	8
Closed Hook Headroom	mm	280	350	420	570	680	1000	1150
Hook Path	mm	1500	1500	1500	1500	1500	1500	1500
Hook Throat	mm	28	33	42.5	51	56	80	80
Handle Length	mm	265	415	415	415	415	415	415
Chain Diameter	mm	5.6	7.1	10	10	19	10	10
Weight (1.5 metre)	kg	6.2	9.6	15.5	27	38.3	90	195
Safety Factor		4:1	4:1	4:1	4:1	4:1	4:1	4:1

Alternative Designs

			
Model: Handy AS Compact Design SWL: 250 & 500 kg Lift: 1500 mm Weight: 2.2 & 2.8 kg	Model: Ergo 360 <i>New</i> Crank Handle SWL: 750 - 6000 kg Lift: 1500 mm Weight: 6.6 – 28.6 kg	Model: PT Pressed Steel SWL: 800 - 6300 kg Lift: 1500 mm Weight: 5.5 - 31 kg	Model: D85 Cast Iron SWL: 750 – 10,000 kg Lift: 1500 mm Weight: 8.2 - 60 kg

Manual and Powered Winches

Automatic Braked Winches

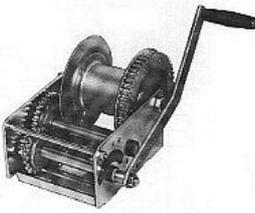
	Model	Max. Line Pull 1 st Layer (kg)	Max. Line Pull Full Drum (kg)	Rope Diameter (mm)	Rope Capacity (m)	Gear Ratio
	K1051	454	272	5.5	18	4.1:1
KX1051	454	272	5.5	18	4.1:1	
K1550	682	320	6	27	5.1:1	
KX1550	682	320	6	27	5.1:1	
K2550	1136	680	8	23	15.8:1	

Worm Gear Winches

	Capacity (kg)	Speed	Rope Diameter (mm)	Rope Capacity (m)	Weight (kg)
	250	1	5	20	9.5
500	1	6.8	25	15	
1000	1	9	35	38	
1500	2	11.5	20	41.5	
2000	2	13	30	70	
3000	2	15	40	150	

Spur Gear Winches

	Capacity (kg)	Speed	Rope Diameter (mm)	Rope Capacity (m)	Weight (kg)
	150	1	4	22	8
300	1	5	40	16	
500	1	6.8	20	16	
1000	1	9	35	38	
2000	1	13	30	70	

Powered Winches

	Capacity (1 st Layer) (kg)	Speed (m/min)	Class	Voltage (v)	Power (kW)	Rope Ø (mm)
	250	2.5	1 Bm	400	0.25	4
250	4.7	1 Bm	400	0.37	4	
250	3.7	1 Bm	230 1ph	0.55	4	
500	6.8	1 Am	400	0.75	6	
630	6.8	1 Bm	400	0.75	6	
980	6	1 Am	400	1.1	9	
1250	6	1 Am	400	1.1	9	
2000	6.8	1 Bm	400	2.2	12	

Tirfor Pulling and Lifting Machines

Tirfor T-500 (standard duty)

The range of Tirfor T-500 and TU machines are of a very compact design and easy to handle. The T-500 series is particularly recommended where lightweight equipment is essential whereas the heavy duty TU series is ideal for arduous environments. Both are suitable for lifting, pulling or work positioning.

	Model	Unit	T-508	T-516	T-532
	Capacity for lifting	kg	800	1600	3200
	Weight	kg	6.6	13.5	24
	Diameter of rope	mm	8.3	11.5	16.3
	Standard rope length	m	20	20	20

(longer rope lengths are available on request)

Tirfor TU (heavy duty)

	Model	Unit	TU-8	TU-16	TU-32
	Capacity for lifting	kg	800	1600	3200
	Weight	kg	8.4	20	27
	Diameter of rope	mm	8.3	11.5	16.3
	Standard rope length	m	20	20	20

(longer rope lengths are available on request)

The Tirfor TU-16 and TU-32 machines are also available with hydraulic power operation. The Tirfor machines are connected to a hydraulic power pack which allows remote operation, either singly or together, 1, 2 or 4 Tirfor machines. The power pack may be supplied with a petrol engine or an electric motor. The TU-32 is also available with air operation.

Jockey (small)

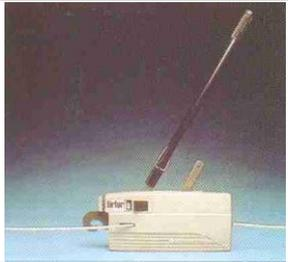
	Model	Unit	Jockey	Jockey J5
	Capacity for lifting	kg	300	500
	Weight	kg	1.750	3.750
	Diameter of rope	mm	4.7	6.5
	Standard rope length	m	10	10

(longer rope lengths are available on request)

Wire Rope Pulling Machine

	Model	Unit	WP800	WP1600	WP3200
	Capacity for pulling	kg	800	1600	3200
	Weight (w/o rope)	kg	12	25	46
	Diameter of rope	mm	8.3	11	16
	Standard rope length	m	20	20	20

Pulley Blocks

Single Sheave Snatch Blocks - Swivel Hook or Shackle



Sheave Ø (mm)	Sheave Ø (inches)	Head Load (tonnes)	Wire Rope Ø (mm)	Sheave Bush / Bearing	Weight (kg)
75	3	2	7 - 9	Bronze Bush	4
114	4 ½	4	10 - 12	Bronze Bush	5.3
152	6	8	16	Roller Bearing	14
152	6	8	20 - 22	Roller Bearing	15
203	8	8	20 - 22	Roller Bearing	20
254	10	12	20 - 22	Roller Bearing	36
305	12	15	24 - 26	Roller Bearing	58

Galvanised Malleable Iron Blocks - Eye or Swivel Latch Hook

Single

Shell (mm)	Shell (inches)	SWL (tonnes)	Rope Ø (mm)	Weight (kg)
76	3	0.2	12	0.9
102	4	0.4	16	1.5
127	5	0.5	18	2.2
152	6	1	24	4.0



Double

Shell (mm)	Shell (inches)	SWL (tonnes)	Rope Ø (mm)	Weight (kg)
76	3	0.4	12	1.0
102	4	0.9	16	2.0
127	5	1.1	18	3.3
152	6	2.0	24	5.5

Treble

Shell (mm)	Shell (inches)	SWL (tonnes)	Rope Ø (mm)	Weight (kg)
102	4	1.0	16	2.6
127	5	1.5	18	5.0

Pulley Block – Hinged Side



Capacity (kg)	Wire Rope Ø (mm)	Sheave Ø (mm)	Weight (kg)
1000	7	85	3.3
2000	13	150	8.9
3200	15	180	15.5
6400	18	210	26.5

Cast steel sheave

One side of the pulley block is hinged and can be opened for easy and quick positioning of the rope on the sheave.

Electric Chain Hoists *(capacities from 125 – 6,300 kg)*



- ✓ Mains contactor as standard, for increased safety
 - ✓ Low voltage 48v contactor control
 - ✓ Insulated pendant control to IP65
 - ✓ Hook path to suit your application
 - ✓ Larger chain collectors available
 - ✓ 3 phase and single phase supply
 - ✓ Slower 10 m/min travel speed also available
- Optional upper and lower limit switches
 - Optional radio remote control
 - Optional stainless steel load chain
 - Optional special paint for hostile environments
- Spark Resistant  also available

Our standard range of electric chain hoists are available with capacities ranging from 125 to 6300 kg, which can be supplied with a hook suspension, hand pushed, hand geared or a power travel trolley.

Model	Capacity (kg)	Chain Falls	FEM	Headroom (mm)	Hoisting Speed (m/min)	Power Travel Speeds single / dual (m/min)	
ST 0501-8/2 1/1	125	1	3m (M6)	367	8 & 2	20	20 & 5
ST 0501-16/4 1/1	125	1	2m (M5)	367	16 & 4	20	20 & 5
ST 0502-8 1/1	250	1	1Am (M4)	367	8	20	20 & 5
ST 0502-8/2 1/1	250	1	1Am (M4)	367	8 & 2	20	20 & 5
ST 0502-8 2/1	500	2	1Am (M4)	428	4	20	20 & 5
ST 0502-8/2 2/1	500	2	1Am (M4)	428	4 & 1	20	20 & 5
ST 1005-8 1/1	500	1	1Am (M4)	372	8	20	20 & 5
ST 1005-8/2 1/1	500	1	1Am (M4)	372	8 & 2	20	20 & 5
ST 1005-8 2/1	1000	2	1Am (M4)	432	4	20	20 & 5
ST 1005-8/2 2/1	1000	2	1Am (M4)	432	4 & 1	20	20 & 5
ST 2010-8 1/1	1000	1	2m (M5)	467	8	20	20 & 5
ST 2010-8/2 1/1	1000	1	2m (M5)	467	8 & 2	20	20 & 5
ST 3016-8 1/1	1600	1	1Bm (M3)	509	8	20	20 & 5
ST 3016-8/2 1/1	1600	1	1Bm (M3)	509	8 & 2	20	20 & 5
ST 3216-8/2 1/1	1600	1	1Bm (M3)	557	8 & 2	20	20 & 5
ST 2010-8 2/1	2000	2	2m (M5)	547	4	20	20 & 5
ST 2010-8/2 2/1	2000	2	2m (M5)	547	4 & 1	20	20 & 5
ST 5025-6/1 1/1	2500	1	1Am (M4)	586	6.3 & 1.5	20	20 & 5
ST 5025-8/2 1/1	2500	1	1Am (M4)	586	8 & 2	20	20 & 5
ST 3016-8 2/1	3200	2	1Bm (M3)	575	4	20	20 & 5
ST 3016-8/2 2/1	3200	2	1Bm (M3)	575	4 & 1	20	20 & 5
ST 3216-8/2 2/1	3200	2	2m (M5)	657	4 & 1	20	20 & 5
ST 5025-6/1 2/1	5000	2	1Am (M4)	697	3.2 & 0.75	20	20 & 5
ST 5025-8/2 2/1	5000	2	1Am (M4)	697	4 & 1	20	20 & 5
ST 6032-6/1.5 2/1	6300	2	1Bm (M3)	697	3.2 & 0.75	20	20 & 5

Please note that the 'Headroom' dimension is for a hoist with hook suspension.

Electric Wire Rope Hoists *(capacities from 1,000 – 160,000 kg)*



- ✓ Mains contactor as standard, for increased safety
 - ✓ Low voltage 48v contactor control
 - ✓ Insulated pendant control to IP65
 - ✓ Longer hook path on request
 - ✓ Different travel speeds available on request
 - ✓ Upper and lower limit switches
 - ✓ Heavy duty rope guide
- Optional radio remote control
 - Optional special paint for hostile environments
 - Spark Resistant  also available

The SH hoist unit can be used as a low headroom monorail hoists with a counterweight for operation on a single girder crane or as a solo travelling hoist for operation on a monorail.

Universal design travel wheels are suitable for sloping and parallel beam flanges.

The electrical equipment for the hoist and cross travel control are integrated in the hoist.

Control is via a suspended control pendant with an emergency stop.

Control is also optionally possible by means of radio remote control. The receiver is integrated into the hoist/crab electrical equipment.

Hoists are also available as a stationary design, double girder trolleys for crane applications and articulating trolleys for curved runways.

Model	Capacity (kg)	Rope Falls	Lift Height * (m)	Headroom ** (mm)	Lifting Speed *** (m/min)	Travel Speeds (m/min)
SH3005	1000	2	12/20	490	12.5/2.0	20/5
SH3005	2000	4	6/10	420	6.3/1.0	20/5
SH3008	3200	4	6/10	420	5.0/0.8	20/5
SH4016	3200	2	12/20	635	8.0/1.3	20/5
SH4012	5000	4	6/10	525	5.0/0.8	20/5
SH5025	5000	2	12/20/40	665	10.0/1.6	20/5
SH5020	8000	4	6/10/20	615	5.0/0.8	20/5
SHR6040	8000	2	17/28.5/57/87	805	6.3/1.0	20/5
SH5025	10000	4	6/10/20	615	5.0/0.8	20/5
SH6050	10000	2	12/20/40/60	1020	8.0/1.3	20/5
SH5032	12500	4	6/10/20	710	6.3/1.0	20/5
SH6063	12500	2	12/20/40/60	1020	6.3/1.0	20/5
SHR6040	16000	4	8.5/14/28.5/42.5	745	3.1/0.5	20/5
SH6050	20000	4	6/10/20/40	1420	4.0/0.6	20/5
SH6063	25000	4	6/10/20/40	1420	3.1/0.5	20/5

* Alternative lift heights available on request

** Can be dependant on hoist body size and beam flange width

*** Alternative lifting speeds available on request

Special Hoists

We offer a range of additional features and hoists to suit special applications.

Special Features

- Thoraxal paint for acid resistance
- Stainless steel load chain
- Foundry duty load chain
- Heat shields

Special Hoists

Low Headroom Hoists

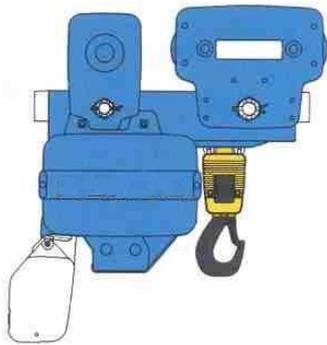

The hoist load hook is situated to one side of the hoist to offer an increased height of lift.

Manulift Hoists



The lifting push button controls are an integral part of the hook block.

Balancers



The hoist balances the load allowing the operator greater control for lifting, guidance and positioning.

Twin Lift Hoists

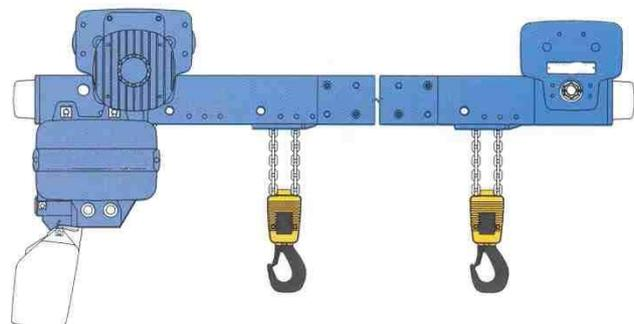

The hoist is fitted with two load chains lifting and lowering simultaneously to ensure the load is stable and lifted horizontally.

Air Chain Hoists

Air hoists are acknowledged as the only conceivable alternative for an increasing number of applications, especially where continuously variable speed and good inching characteristics are essential.

Air hoists are especially suitable for hazardous areas where they resist high humidity, vapour or smoke as well as extreme temperatures from - 20° C up to + 70° C.

Standard 'Mini' Series

- Competitive price and extremely compact
- Suitable for lube free operation
- Also suitable for horizontal pulling
- Suitable for hazardous areas



Type		Mini 125	Mini 250	Mini 500	Mini 1000
Capacity	kg	125	250	500	1000
Chain falls		1	1	1	1
Motor output	kW	0.4	0.4	1.0	1.0
Air pressure	bar	6	6	6	6
Heights of lift	m	3 / 5 / 8			
Lengths of control	m	2 / 4 / 6			
Control		Pendant			
Air connection		G ³ / ₈	G ³ / ₈	G ¹ / ₂	G ¹ / ₂
Hose inside ø	mm	9	9	13	13
Closed headroom	mm	328	328	458	458
Weight 3 metre lift	kg	9.5	10.5	21	23

Heavy-Duty 'Profi' Series

- Robust construction, minimum headroom
- Low weight, easily transportable
- Easy operation and little maintenance
- Unlimited switching at continuous working



Type		025TS	05TS	1 TS	2TS	3TI	6TI
Capacity	kg	125	500	1000	2000	3000	6000
Chain falls		1	1	1	2	1	2
Motor output	kW	1.0	1.0	1.0	1.0	2.2	2.2
Air pressure	bar	6	6	6	6	6	6
Standard lift	m	3 metres but supplied to suit your application					
Lengths of control	m	2 metres but supplied to suit your application					
Control		Rope, chain or pendant					
Air connection		G ¹ / ₂	G ¹ / ₂	G ¹ / ₂	G ¹ / ₂	G ³ / ₄	G ³ / ₄
Hose inside ø	mm	15	15	15	15	19	19
Closed headroom*	mm	452	395	410	544	540	650
Weight 3 metre lift	kg	21.5	24	27.5	34.5	67	88

Larger capacities are available on request

* Chain containers increase the headroom.

Jib Cranes

Freestanding, wall or column mounted jib cranes - capacities from 40 kg to 6300 kg and arm radius up to 7 metres (depending on arm design). Can be supplied with manual, electric or air operated hoists.

Wall or Column Mounted Overbraced - 180°

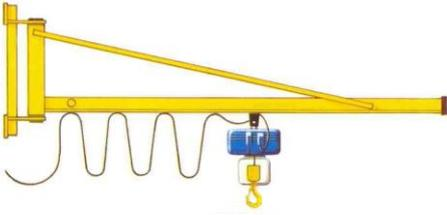

Secured to existing walls or building columns

Wall or Column Mounted Underbraced - 180°

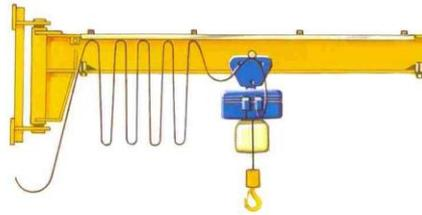

Secured to existing walls or building columns

Post Mounted Overbraced - 300°



Secured to existing concrete floors or to a prepared foundation

Post Mounted Underbraced - 300°

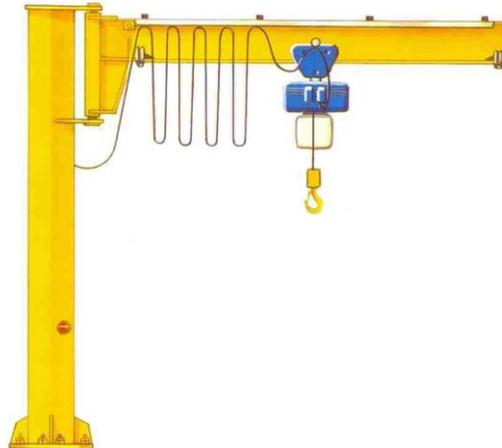

Secured to existing concrete floors or to a prepared foundation

Post Mounted Underbraced - 360°



Secured to existing concrete floors or to a prepared foundation
Powered slewing option available as an option

Post Mounted Articulated Arm

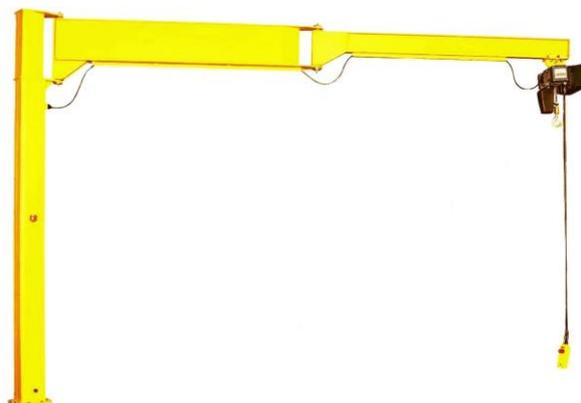

Secured to existing concrete floors or to a prepared foundation

Overhead Travelling Cranes

Overhead travelling cranes are the answer to many lifting and movement problems in factories, warehouses and stockyards. Cranes may be overslung or underslung with single or double girders to suit the building and application involved. Operation can be manual or power driven in the long travel, cross travel and lifting movements or a combination of the two.

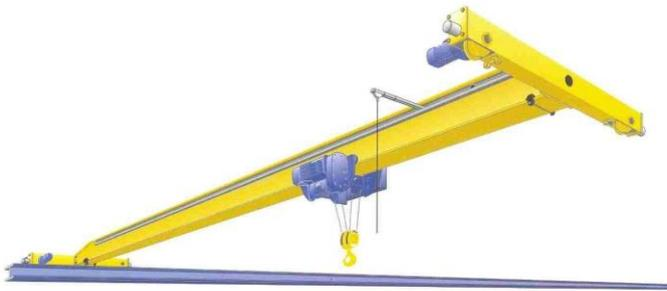

Single Girder overslung (top running) travelling crane.

Maximum Capacity: 10 tonne
Maximum Span: 36 metres

Hoist Options: Chain or Wire Rope

Control Options: Manual Hand Chain
Mobile Pendant
Remote Control



Single Girder underslung (bottom running) travelling crane.

Maximum Capacity: 8 tonne
Maximum Span: 25 metres

Hoist Options: Chain or Wire Rope

Control Options: Manual Hand Chain
Mobile Pendant
Remote Control

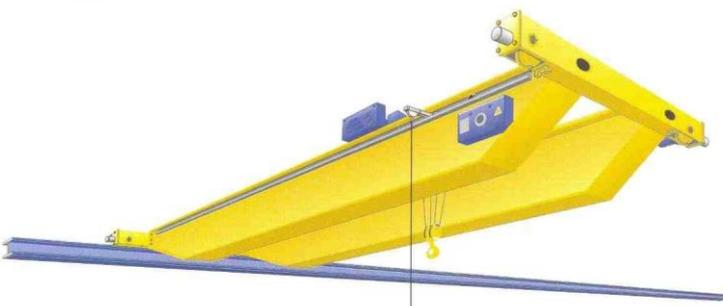

Double Girder overslung (top running) travelling crane.

Maximum Capacity: 80 tonne
Maximum Span: 36 metres

Hoist Options: Wire Rope

Control Options: Mobile Pendant
Remote Control

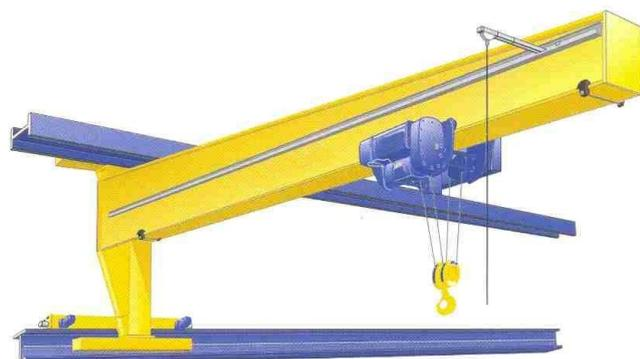

Single Girder wall travelling crane.

Maximum Capacity: 5 tonne
Maximum Span: 10 metres

Hoist Options: Chain or Wire Rope

Control Options: Manual
Mobile Pendant
Remote Control

Modular Cranes

Modular runway beams and cranes are made up from pre-formed lightweight pressed steel tracks. They are normally supplied with a manually operated cross and downshop travel and can be fitted with a manual, electric or air hoist. We also design, manufacture, install, test and certify the runway or crane complete with all supporting steelwork. Examples shown below.

Single Girder Runway Beam

Maximum Capacity: 2000 kg

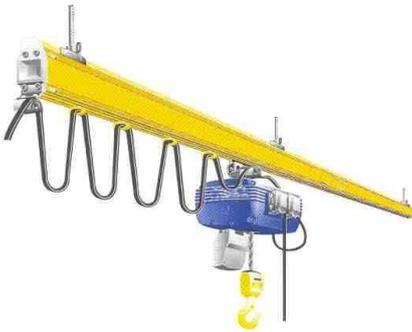

Double Girder Runway Beam

Maximum Capacity: 2000 kg

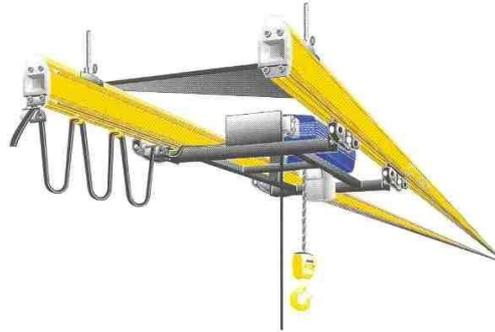

Single Girder Crane

Maximum Capacity: 1000 kg



Double Girder Crane

Maximum Capacity: 2000 kg



Double Girder Crane c/w 'Stooled Up' Bridge

Maximum Capacity: 2000 kg



Double Girder Crane c/w Powered Travel

Maximum Capacity: 1600 kg



Mobile Gantries

Mobile Lightweight Gantry

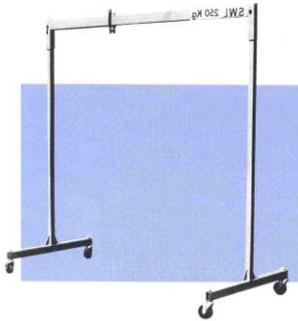

- Capacities up to 500 kg
- Ideal for handling small loads
- Supplied with a top running hand pushed trolley
- Lightweight design
- Supplied with 100 mm diameter nylon castors
- Height under beam 2438 mm
- Width between frames 2438 mm

Mobile Packaway Gantry



- Capacities up to 2000 kg
- Designed for easy dismantling and transportation
- Lightweight design
- Supplied with cast iron castors
- Standard height under beam 3048 mm
- Standard width between 'A' frames 3353 mm
- **Also manufactured to your specification**

Mobile Fixed Height Gantry



- Capacities up to 5000 kg
- Bracing can be internal (as shown) or external
- Supplied with cast iron castors
- Options include polyurethane tyred castors and parking jacks
- Standard height under beam 3048 mm
- Standard width between 'A' frames 3353 mm
- **Also manufactured to your specification**

Mobile Adjustable Height Gantry

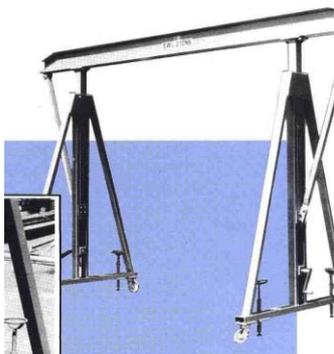

- Capacities up to 6000 kg
- Infinitely variable adjustment of up to two thirds of the basic height obtained by screw and bevel gearing, which is self sustaining
- Options include polyurethane tyred castors and parking jacks
- Standard height under beam 2743 - 4115 mm
- Standard width between 'A' frames 3353 mm
- **Also manufactured to your specification**

Aluminium Gantries and Tripods

Ideal for site changes. The gantry is easily erected by one person due to link between beam and supports.

Fold out the four supports, secure with bolts and adjust to the height required. Supplied with an erection aid.

Fixed Adjustable Height Aluminium Gantry - type 530

	Safe Working Load:	750 or 1500 kg
	Overall Height:	1870 - 3080 mm
	Overall Width:	4115 mm
	Trolley Suspension Height:	1510 - 2720 mm
	Weight:	85 kg
Supplied with a top running hand pushed trolley.		

Mobile Adjustable Height Aluminium Gantry - type 535

	Safe Working Load:	1000 kg
	Overall Height:	2400 - 3200 mm
	Overall Width:	4000 mm
	Trolley Suspension Height:	2000 - 2800 mm
	Weight:	130 kg
Supplied with a top running hand pushed trolley.		

Fixed Adjustable Height Aluminium Tripod

	<ul style="list-style-type: none"> ✓ Light Aluminium construction ✓ Telescopic legs for compact transportation ✓ Spiked feet as standard ✓ Swivel suspension eye
	<ul style="list-style-type: none"> ▪ Optional rubber feet for solid ground ▪ Optional safety chain for smooth ground

Model	Capacity (kg)	Length of Support L Min/Max. (mm)	Clearance Height H Min/Max. (mm)	Spreading Angle B Min/Max. (mm)	Weight (kg)
D-250	250	1180 / 1880	940 / 1580	950 / 1500	10
D-500	500	1500 / 2500	1150 / 2050	1200 / 1950	17
D-500/En795	500	1500 / 2500	1150 / 2050	1200 / 1950	17
D-503	500	1760 / 3000	1450 / 2630	1430 / 2390	20
D-1000	1000	1780 / 3000	1380 / 2540	1650 / 2350	27
D-1004	1000	2250 / 4000	1860 / 3440	1790 / 3070	36

i) Maximum spreading angle (25°).

ii) Permitted for man riding applications up to 150 kg according to EN 795. Equipped with rubber plates and safety chain.

Lifting / Spreader Beams

Designed and manufactured to suit your individual application to lift large or awkward loads with a high degree of safety.

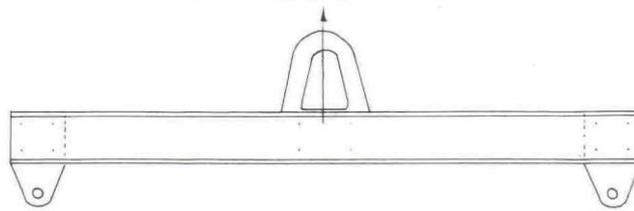

Two point pick up with a central lifting eye

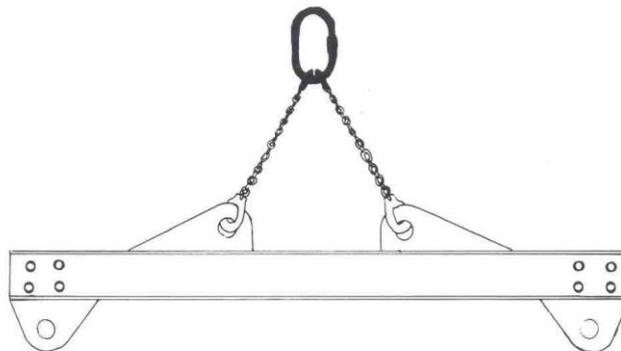

Two point pick up with a 2-leg sling suspension inset from each end



Two point pick up with a 2-leg sling suspension at each end

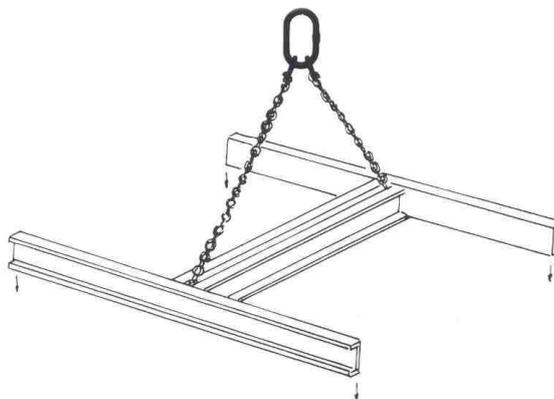

'H' frame four point pick up with a 2-leg suspension

These illustrations show simple examples of a few beam types only. Please consult our technical sales staff regarding your specific application.

'C' Hooks

TCK – Self Balancing 'C' Hook

Model	WLL (tonnes)	Tine Length (mm)	Wall Thickness (mm)
TCK0.5/300	0.5	300	400
TCK0.5/500	0.5	500	400
TCK0.5/800	0.5	800	400
TCK1/300	1	300	450
TCK1/500	1	500	450
TCK1/800	1	800	450
TCK2/300	2	300	500
TCK2/500	2	500	500
TCK2/800	2	800	500
TCK2/1000	2	1000	500
TCK3/300	3	300	500
TCK3/500	3	500	500
TCK3/800	3	800	500
TCK3/1000	3	1000	500

Please note that these are made to order.

BRL - Spring Balanced 'C' Hook

Designed for lifting and handling pipe sections in the horizontal position. Spring balanced and fitted with and adjustable end stop and safety chain. These are made to order.

Model	WLL (tonnes)	Pipe Length (metres)
BRL1.0/1000	1	1
BRL2.0/1000	2	1
BRL3.0/1000	3	1
BRL1.0/2000	1	2
BRL2.0/2000	2	2
BRL3.0/2000	3	2
BRL3.0/3000	3	3

TCS - Coil Turning Hook

Designed to pick up coils in the horizontal position and lower into the vertical position and 'vice versa'.

Model	WLL (kg)	Coil Width (mm)	Min. Internal Ø (mm)	Weight (kg)
TCS0.5/120	500	50 - 120	220	9
TCS0.5/200	500	100 - 200	300	10
TCS1.0/200	1000	100 - 200	300	13
TCS1.0/300	1000	200 - 300	400	15
TCS2.0/200	2000	100 - 200	300	21
TCS2.0/300	2000	200 - 300	400	23
TCS3.0/200	3000	100 - 200	300	34
TCS3.0/300	3000	200 - 300	400	39

Pipe Hooks and Safety Hook

Pipe Laying Hooks

	Capacity (kg)	Pipe Length (mm)	Throat Width (mm)	Weight (kg)
	1000	up to 1000 mm	190	24
	3000	up to 1000 mm	260	45

Pipe Laying Hooks – Automatic Counterbalance

	Capacity (kg)	Pipe Length (mm)	Throat Width (mm)	Weight (kg)
	350 - 1000	up to 3000 mm	300	180
	1000 - 3000	up to 3000 mm	460	310

Pipe Laying Hooks - Chain Sling Suspension

	Capacity (kg)	Pipe Length (mm)	Throat Width (mm)	Weight (kg)
	2500	up to 4000	250	56
	4000	up to 4000	320	101

Pipe Laying Hooks - Chain Sling Suspension

	Capacity (kg)	Leg Angle (mm)	Wall Thickness (mm)	Weight (kg)
	2000	60 - 90	0 - 40	2.4
	4000	60 - 90	0 - 50	5.6
	6000	60 - 90	0 - 60	8.3
	8000	60 - 90	0 - 70	13.5
	10000	60 - 90	0 - 80	17.8

	Capacity (kg)	Leg Angle (mm)	Wall Thickness (mm)	Weight (kg)
	2000	90 - 120	0 - 30	2.4
	4000	90 - 120	0 - 40	5.6
	6000	90 - 120	20 - 50	8.3
	8000	90 - 120	35 - 65	13.5
	10000	90 - 120	30 - 75	17.8

Automatic Safety Hook – available in 2, 5, 10, 15 and 20 tonne

Automatically hooks up, safety locks and releases so the risk of injury is dramatically reduced.



Powered Vacuum Lifting Beams

Powered vacuum lifting beams are a cost effective way to lift and rotate (if required) a variety of products including steel, wood, plastic, glass and wood. Our vacuum lifting beams can be supplied with single or multiple adjustable suction pads to suit the product, some of which can be switched off by lever valve if required – mains or battery powered.

We can also offer a range of adjustable work stands using vacuum power to secure the load.

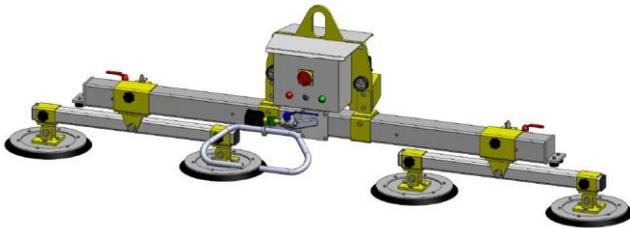

All devices are fitted with rubber sealing rings with the quality of rubber designed for normal lifting conditions.

- ❖ Standard - **BLACK**
- ❖ Oil resistant - **BLUE**
- ❖ Heat resistant - **RED**

- Steel
- Wood
- Plastic
- Glass
- Stone

Type	Pads	Model	Capacity	Max. Sheet Size	Suction Pads	Unit Weight
	1	H-E-150 H-E-300 H-E-500 H-E-750	150 300 500 750	2000 x 1000 mm (2 mm) 2000 x 1000 mm (2 mm) 2000 x 1000 mm (2 mm) 2000 x 2000 mm (2 mm)	1 @ 270 mm 1 @ 360 mm 1 @ 495 mm 1 @ 650 mm	48 kg 48 kg 56 kg 68 kg
	2	H-2-150 H-2-300 H-2-500 H-2-750 H-2-1000 H-2-1250	150 300 500 750 1000 1250	3000 x 1500 mm (2 mm) 3000 x 1500 mm (2 mm) 3000 x 1500 mm (2 mm) 3000 x 1500 mm (2 mm) 3000 x 1500 mm (2 mm) 3000 x 1500 mm (2 mm)	2 @ 170 mm 2 @ 315 mm 2 @ 340 mm 2 @ 495 mm 2 @ 495 mm 2 @ 650 mm	75 kg 90 kg 95 kg 120 kg 130 kg 160 kg
	4	H-4Q-150 H-4Q-300 H-4Q-500 H-4Q-750 H-4Q-1000 H-4Q-1250	150 300 500 750 1000 1250	2500 x 1250 mm (2 mm) 2500 x 1250 mm (2 mm) 2500 x 1250 mm (2 mm) 2500 x 1250 mm (2 mm) 2500 x 1250 mm (2 mm) 2500 x 1250 mm (2 mm)	4 @ 180 mm 4 @ 270 mm 4 @ 270 mm 4 @ 315 mm 4 @ 340 mm 4 @ 495 mm	100 kg 110 kg 130 kg 140 kg 155 kg 170 kg
	4	H-4K-300 H-4K-500 H-4K-750 H-4K-1000 H-4K-1250	300 500 750 1000 1250	4000 x 2000 mm (2 mm) 4000 x 2000 mm (2 mm) 4000 x 2000 mm (2 mm) 4000 x 2000 mm (2 mm) 4000 x 2000 mm (2 mm)	4 @ 375 mm 4 @ 375 mm 4 @ 375 mm 4 @ 375 mm 4 @ 495 mm	170 kg 175 kg 190 kg 195 kg 215 kg
	6	H-6Q-150 H-6Q-300 H-6Q-500 H-6Q-750 H-6Q-1000 H-6Q-1250	150 300 500 750 1000 1250	3000 x 1500 mm (1 mm) 3000 x 1500 mm (1 mm) 3000 x 1500 mm (1 mm) 3000 x 1500 mm (1 mm) 3000 x 1500 mm (1 mm) 3000 x 1500 mm (1 mm)	6 @ 130 mm 6 @ 170 mm 6 @ 210 mm 6 @ 270 mm 6 @ 315 mm 6 @ 340 mm	88 kg 90 kg 95 kg 175 kg 180 kg 195 kg
	8	H-8Q-150 H-8Q-300 H-8Q-500 H-8Q-750 H-8Q-1000 H-8Q-1250	150 300 500 750 1000 1250	4000 x 2000 mm (1 mm) 4000 x 2000 mm (1 mm) 4000 x 2000 mm (1 mm) 4000 x 2000 mm (1 mm) 4000 x 2000 mm (1 mm) 4000 x 2000 mm (1 mm)	8 @ 130 mm 8 @ 130 mm 8 @ 210 mm 8 @ 210 mm 8 @ 270 mm 8 @ 315 mm	90 kg 95 kg 115 kg 120 kg 195 kg 210 kg

Options Available:

- 90° and 180° rotation
- resting trestles
- weld-on hooks
- manual and powered rotation
- foldable beams
- chain suspension
- coil handling design
- safety webbings
- cable remote control

Self-Suction Vacuum Lifting Beams

Our self-suction vacuum lifting beams can be suspended from a hoist hook with **NO ELECTRICS** required to operate them. A low dead weight means little loss of crane capacity and they are virtually maintenance free, even in full production.

Each vacuum-lifting beam is supplied with an audio/visual warning system to warn the operator of excess weight and loss of vacuum. The suction feet will not damage the item to be lifted. Operation is simply place down and lift up, with the vacuum automatically switches from suction to no suction each time the beam is supported.

The vacuum-lifting beam can be supplied with a single or adjustable multiple suction feet with capacities ranging from 75 to 4000 kg.

When lifting large area measurements it is imperative that there is no flexing/bending of the sheet.

All devices are fitted with rubber sealing rings with the quality of rubber designed for normal lifting conditions.

- ❖ Standard - **BLACK**
- ❖ Oil resistant - **BLUE**
- ❖ Heat resistant - **RED**

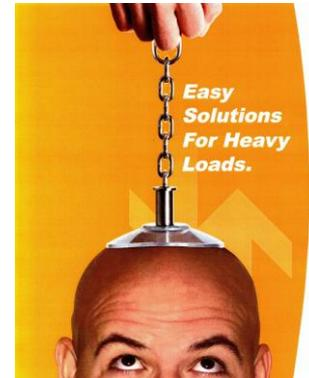

Type	Pads	Model	Capacity	Max. Sheet Size	Suction Pads	Unit Weight
	1	U01-E U02-E U075-E U125-E	5 - 75 kg 10 - 270 kg 35 - 640 kg 35 - 1100 kg	1000 x 1000 mm (2 mm) 2000 x 1000 mm (2 mm) 2000 x 1000 mm (2 mm) 2000 x 2000 mm (2 mm)	1 @ 210 mm 1 @ 350 mm 1 @ 480 mm 1 @ 625 mm	6.7 kg 25 kg 78 kg 135 kg
	4	U250-4Q U400-4Q	70 - 2300 kg 120 - 4000 kg	3000 x 2000 mm (2 mm) 3000 x 2000 mm (2 mm)	4 @ 480 mm 4 @ 625 mm	450 kg 400 kg
	2	U02-2 U075-2 U125-2 U250-2	5 - 300 kg 20 - 750 kg 25 - 1250 kg 70 - 2100 kg	3000 x 1500 mm (2 mm) 3000 x 1500 mm (2 mm) 3000 x 1500 mm (2 mm) 3500 x 2000 mm (2 mm)	2 @ 350 mm 2 @ 415 mm 2 @ 625 mm 2 @ 625 mm	67 kg 141 kg 285 kg 465 kg
	3	U075-3	20 - 750 kg	3000 x 1500 mm (2 mm)	3 @ 350 mm	151 kg
	4	U02-4 U125-4 U250-4	5 - 300 kg 25 - 1250 kg 70 - 2200 kg	3000 x 1500 mm (2 mm) 6000 x 2000 mm (2 mm) 6000 x 2000 mm (2 mm)	4 @ 250 mm 4 @ 415 mm 4 @ 625 mm	75 kg 355 kg 770 kg
	5	U400-5	90 - 4000 kg	6000 x 2000 mm (2 mm)	5 @ 625 mm	870 kg
	6	U02-6 U075-6 U125-6 U400-6	5 - 270 kg 20 - 650 kg 25 - 1250 kg 90 - 4000 kg	3000 x 1500 mm (1 mm) 3000 x 1500 mm (1 mm) 3000 x 1500 mm (1 mm) 10000 x 2000 mm (2 mm)	6 @ 210 mm 6 @ 250 mm 6 @ 350 mm 6 @ 625 mm	86 kg 175 kg 350 kg 1000 kg
	10	U250-10 U400-10	70 - 2200 kg 100 - 4000 kg	6000 x 2500 mm (2 mm) 6200 x 2500 mm (2 mm)	10 @ 350 mm 10 @ 480 mm	725 kg 1250 kg

VacuEasylift Vacuum Lifting Hoists

The VacuEasylift is a manually operated powered vacuum lifting device that handles almost any type of load. The extremely smooth and quick operation is accomplished by using the same handle to lift, lower and release the load and by using the same vacuum to hold and lift the load. By supplying the VacuEasylift with a vast variety of suction feet it can be used to lift anything from a cardboard box to a television.

Typical Applications

- Boxes
- Reels
- Wood
- Steel
- Windows
- Sacks
- Cheese
- Paper
- Pallets
- Televisions
- Plastic
- Stone

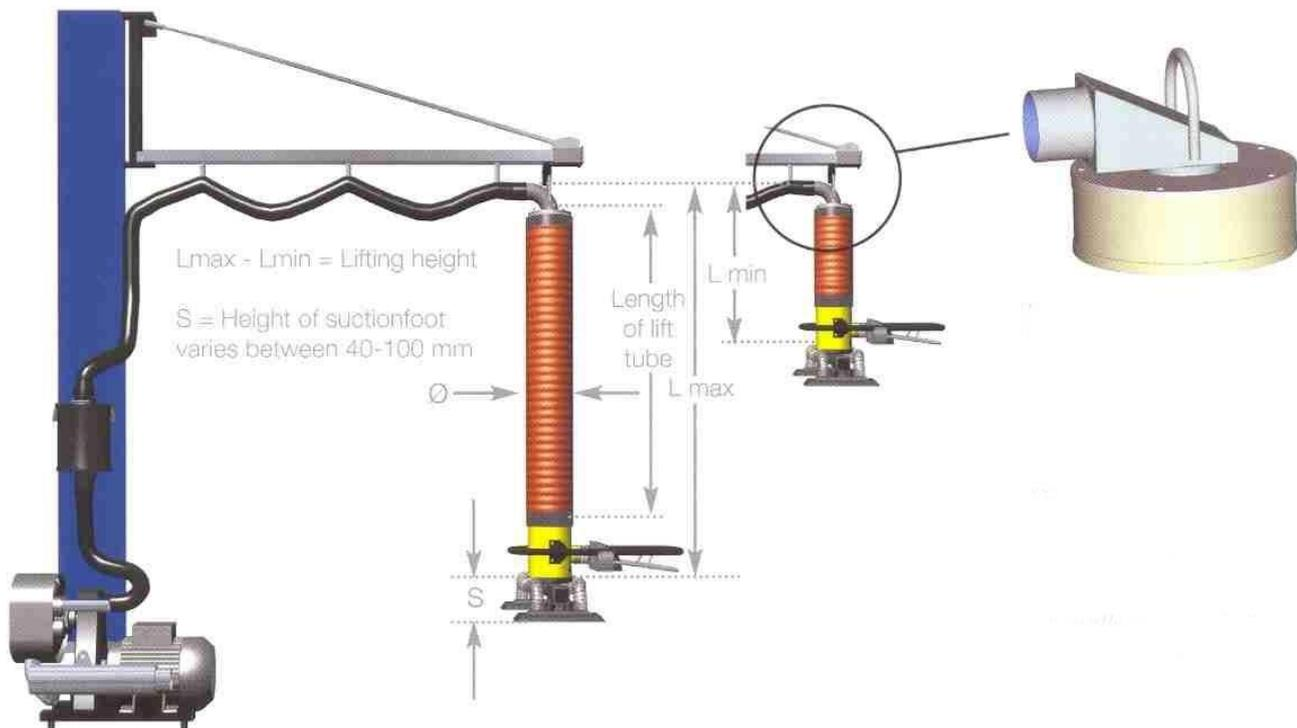

Specifications

Model	VM80	VM100/120/140		VM160/180		VM200/230		VM250	VM2160/2180		VM300
Lifting cap. kg	20	30/40/50		60/80		100/120		180	120/160		270
Length of lift tube	2000	2500	4000	2500	4000	2500	4000	2500	2500	4000	2500
Ø mm	80	100/120/140		160/180		200/230		250	2x160/2x180		300
L max.	2240	2670	4170	2690	4190	2690	4190	2690	2630	4130	2690
L min.	740	870	1570	890	1590	990	1790	1190	830	1530	1190
Lifting height	1500	1800	2600	1800	2600	1700	2400	1500	1800	2600	1500
Extended, flexible handle	N/A	Flexed extensions up to 800+800 mm standard		Flexed extensions up to 800+800 mm standard		Flexed extensions up to 800+800 mm standard		N/A	Available on request		N/A

Optional Extras include a bottom swivel, quick release couplings, a 90 degree angle adaptor, white non marking suction pads, stainless steel fittings etc.

Permanent Lifting Magnets

Permanent lifting magnets manufactured from two-pole design, high energy magnets with an improved easy switching system with only one hand. Suitable for flat and round sections.

Safety Factor: 3 : 1

Applications:

- Workshops
- Construction sites
- Warehouses
- Steel stockholder

Hand Magnets



Factors that reduce the magnetic clamping force:-

Air gap: An air gap between the magnet and the load such as surface damage, paint, dust and heavy mill scale.

Material thickness: Plates thinner than the recommended minimum thickness will reduce the lifting capacity – please contact us for advice.

Temperature: The temperature of the load must not exceed 200°C.

Contact area: Full lifting capacity can only be achieved when the magnet has full contact area with the component being lifted.

Material Type: Certain materials have different abilities to carry magnetism so a reduction factor must be applied. Please contact us for more details.

Model	Flat Material		Round Material		Maximum Length Of Material (mm)	Dimensions			
	Working Load Limit (WLL) (kg) **	Minimum thickness for WLL (mm)	Working Load Limit (WLL) (kg) **	Diameter Min./Max. (mm)		Length (mm)	Width (mm)	Height inc. Eye (mm)	Weight (kg)
PLM 125	100	15	50	200 - 300	2000	122	69	185	6
PLM 250	300	19	150	200 - 300	2500	192	95	225	15.5
PLM 500	500	25	250	200 - 400	3000	232	120	270	29.5
PLM 1000	800	35	400	200 - 400	3500	302	154	320	53
PLM 1500	1000	40	500	200 - 400	3500	332	154	320	60

** Maximum lifting capacity is achieved by using mild steels with the noted minimum thickness. Mild steel st37 – Fe 360 to BS EN 10 025 1990 (DIN 17100)

Tilting Lifting Attachment



Battery Lifting Magnets



- Powered by a built-in 12-volt battery for at least 8 hours operation.
- Hand held IR remote control available.
- Bail sensor prevents magnet de-energisation while lifting a load.
- Dual buttons for RELEASE.
- Visual and audible alarms indicate low battery level.
- Magnet cannot be turned on if battery charge is too low.
- Built-in, temperature compensated, automatic cut-off charger.

BM Series for Flat Material Handling

BM1350, BM2500, BM5000

These models are designed to lift heavy, thick plates and blocks. The maximum lift capacity is obtained on a material thickness of 50 mm and above and on a relatively flat, machined surface. Model BM5000 has two independently suspended '2500' magnets to lift large objects.

BM3600

This model is specially designed for plate lifting from 3 mm thickness and up. Provided a smooth and flat surface, this magnet will lift a plate of 2400 x 1800 mm of 3 mm thick and even 6 x 3 metres when 25 mm thick! The 'tip off' feature allows to drop excess plates in case multiple plates are picked up from a stack.

BMP series for Flat, Rounds and Structural Sections

BMP1800, BMP3600

These so-called bi-polar lifting magnets with V shaped pole shoes are designed to lift both flat and round material as well as 'I' and 'H' beams, angles, channels, tees and zeos. The maximum lift capacity is obtained on a material thickness of 50 mm and above. Thanks to the good depth of field, these models cope very well with irregular surfaces.

Technical Specifications

Model		BM1350	BM2500	BM3600	BM5000	BMP1800	BMP3600
Magnet details:		3 pole flat 1 magnet	3 pole flat 1 magnet	3 pole flat 1 magnet	3 pole flat 2 magnets	2 pole V shaped 1 magnet	2 pole V shaped 1 magnet
WLL - flat material	kg	1350	2500	3600	5000	1800	3600
WLL - round material	kg	-	-	-	-	1100	2200
Tested breakaway	kg	2700	5000	7200	10000	3600	7200
Base length x width	mm	272 x 242	400 x 242	1050 x 240	1200 x 300	470 x 242	760 x 262
Height to hook eye	mm	460	460	460	460	610	620
Weight	kg	60	72	180	203	167	420
Recommended battery	V/Ah	12/35	12/50	12/70	12/70	12/70	12/70
Type of battery	DIN	43539-2	43539-3	43539-3	43539-3	43539-3	43539-3
Discharge time at 50% duty	h	8	8	8	8	8	8

* Performance rating on ground, 50 mm thick S235 JR/AISI 1020 plate.

Pallet Forks and Brick Grabs

Pallet or Crane Forks type TKG

Designed to convert a crane into a forklift truck for handling palletised loads. Two types are available, manual or automatic balance with or without adjustable tines.

	Model	WLL (kg)	Pallet m ³	Weight (kg)
	TKG1.0vh (manual balance)	0 - 1000	1	130
	TKG1.0vhs (automatic balance)	200 - 1000	1	140
	TKG2.0vh (manual balance)	0 - 2000	1	200
	TKG2.0vhs (automatic balance)	400 - 2000	1	220

Block Grabs type TBG

A scissor type grab designed to transport all materials with parallel surfaces that can withstand the clamping pressure twice as high as the load being lifted.

	Model	WLL (kg)	Block Size (mm)	Weight (kg)
	TBG 500S	500	0 - 150	27
	TBG 1000S	1000	50 - 250	50
	TBG 200L	200	200 - 500	49
	TBG 300L	300	400 - 700	52
	TBG 500L	500	600 - 900	55
	TBG 1000L	1000	800 - 1100	72

Brick Grabs type ISG-5

	WLL (kg)	Grab Opening (mm)	Clear Height (mm)	Weight (kg)
	1800	600 - 1130	400 - 925	260
	Designed to lift palletised brick loads (the bricks must be securely bound). Jaws are fitted with soft liners to minimise damage to the load. The grab is fitted with an automatic 'open/closed' device that enables a single operator to stack or unstack palletised bound loads.			

Container Lifting Lugs

	Model	WLL (tonnes)	Chain Angle	Type	Weight (kg)
	CLT	56 (set of 4)	Vertical	Top Lifting	28
	Model	WLL (tonnes)	Chain Angle	Type	Weight (kg)
	CLB	32 (set of 4)	Degree 50	Side Lifting	18
	CLB	40 (set of 4)	Degree 36	Side Lifting	18
	CLB	50 (set of 4)	Vertical	Side Lifting	18

Lifting and Girder Clamps

Universal Plate Clamps type 92 and CZ

These clamps lift and turn over plates in one smooth operation. Available with a standard hook ring (as shown) or with a short chain sling for easy fitting directly on to a crane hook. Hardened steel jaws are suitable for all structural steel below HRC 30/Brinell 300 surface hardness.

	Model	WLL (kg)	Plate Thickness (mm)	Weight (kg)
	92-500	50 - 500	0 - 16	1.5
	92-1500	150 - 1500	0 - 20	3
	92-2000	200 - 2000	0 - 32	8
	92-3000	300 - 3000	0 - 32	12
	CZ 4	480 - 4000	0 - 32	12
	CZ 4L	480 - 4000	30 - 60	18
	CZ 6	720 - 6000	0 - 50	21
	CZ 6L	720 - 6000	50 - 100	28
	CZ 8	960 - 8000	0 - 50	26
	CZ 8L	960 - 8000	50 - 100	32
	CZ 10	1500 - 10000	0 - 50	30
	CZ 10L	1500 - 10000	50 - 100	37
	CZ 12	1800 - 12000	0 - 50	54
	CZ 12L	1800 - 12000	50 - 100	63
	CZ 15	3000 - 15000	0 - 50	75
CZ 15L	3000 - 15000	50 - 100	88	
CZ 20	4000 - 20000	0 - 65	123	
CZ 20L	4000 - 20000	65 - 130	136	

Larger sizes available on request.

Hinged Universal Plate Clamps type CY and CX

The CY clamp is based on the CZ clamp incorporating a hinged hook ring. They have been developed especially for the handling of plate at any angle. The CX clamp is particularly suitable for handling fabrications because of the facility of the lifting eye and link.

Hardened steel jaws are suitable for all structural steel up to 300 Brinell surface hardness.

	Model	WLL (kg)	Plate Thickness (mm)	Weight (kg)
	CY1	200 - 1000	0 - 20	4.6
	CY2	400 - 2000	0 - 32	14
	CY3	600 - 3000	0 - 32	14
	CX1500	225 - 1500	0 - 20	7
	CX3000	450 - 3000	0 - 32	12
	CX3000L	450 - 3000	30 - 60	15
	CX6000	1200 - 6000	0 - 50	38
	CX6000L	1200 - 6000	50 - 100	48
	CX8000	1600 - 8000	0 - 50	39
	CX8000L	1600 - 8000	50 - 100	51
	CX10000	2000 - 10000	0 - 50	61
	CX10000L	2000 - 10000	50 - 100	76

Lifting and Girder Clamps

High Grip Universal Plate Clamp type HG

Designed with a higher grip on the lifted plate, particularly suitable for hardened and stainless steel.

	Model	WLL (kg)	Plate (mm)	Weight (kg)
	HG 500	25 - 500	0 - 10	5
	HG 1000	50 - 1000	0 - 16	12
	HG 2000	200 - 2000	0 - 20	22
	HG 3000	300 - 3000	0 - 20	28
	HG 4000	400 - 4000	0 - 20	34

Gentle Grip Universal Plate Clamp type LJ

Designed to lift plate without marking or damaging the surface finish.

	Model	WLL (kg)	Plate (mm)	Weight (kg)
	LJ 500	25 - 500	0 - 10	3.5
	LJ 1500	180 - 1500	0 - 20	12

Heavy Duty Girder Clamp type CG

Designed to lift large structural beams and fitted with a positive lock on to one of the uppermost edges which will allow the beam to be set down with the web or flange vertical.

	Model	WLL (kg)	Flange (mm)	Weight (kg)
	CG 1	100 - 1000	0 - 16	6
	CG 2	200 - 2000	0 - 32	14
	CG 4	400 - 4000	0 - 32	19
	CG 6	600 - 6000	12 - 50	37
	CG 8	800 - 8000	12 - 50	40

Girder Clamp type TTR

This clamp has been developed to handle structural beams with the flanges in the vertical position.

	Model	WLL (kg)	Flange (mm)	Weight (kg)
	TTR 750	40 - 750	5 - 16	3.5
	TTR 1500	150 - 1500	5 - 25	10
	TTR 3000	300 - 3000	5 - 28	12

Horizontal Girder Clamp type TTG

Designed to lift and transport steel beams with the flanges in a horizontal position. The clamp is fitted with a locking lever and can be used in pairs or singly.

	Model	WLL (kg)	Plate (mm)	Weight (kg)
	TTG 500	25 - 500	0 - 20	3
	TTG 1500	75 - 1500	0 - 30	5.5
	TTG 3000	150 - 3000	0 - 35	11
	TTG 4500	450 - 4500	0 - 40	14.5
TTG 7500	750 - 7500	0 - 45	28	

Lifting and Girder Clamps

Heavy Duty Horizontal Plate Clamps type CH and HH (pairs)

Used in pairs with a 2-leg sling these clamps are designed to move plate in the horizontal plane. Supplied with smooth jaws. Maximum sling angle 90 degrees.

	Model	WLL / pair (kg)	Plate (mm)	Weight / pair (kg)
	CH1	1000	5 - 32	8
	CH2	2000	5 - 32	11
	CH2/L	2000	20 - 50	12
	CH4	4000	5 - 50	17
	CH4/L	4000	50 - 100	23
	CH6	6000	5 - 75	46
	CH6/L	6000	50 - 125	56
	CH8	8000	5 - 75	53
	CH8/L	8000	50 - 125	60
	HH8 - high strength	8000	5 - 50	21
HH8/L - high strength	8000	50 - 100	28	

Roller Toe Horizontal Clamps type RH (pairs)

The contact area features a roller toe to assist correct location and allows reduced marking during lifting.

	Model	WLL / pair (kg)	Plate (mm)	Weight / pair (kg)
	RH 1500	1500	5 - 60	12
	RH 2500	2500	10 - 70	21
	RH 3500	3500	10 - 80	28
	RH 5000	5000	10 - 102	72

Horizontal Thin Sheet Clamps type THK (pairs)

A horizontal plate clamp designed with reversed jaws to handle thin sheets that deflect when being lifted.

	Model	WLL (kg)	Plate (mm)	Weight (kg)
	THK 750	40 - 750	0 - 25	3
	THK 1500	75 - 1500	0 - 35	6
	THK 3000	150 - 3000	0 - 35	11
	THK 4500	225 - 4500	0 - 45	16
	THK 6000	300 - 6000	0 - 60	23
	THK 9000	450 - 9000	0 - 60	35

Screw Cam Pulling Clamps type TSD

Designed for pulling and also available with an additional lug enabling it to pull in two different directions.

	Model	WLL (kg)	Plate Size (mm)	Weight (kg)
	TSD 1500	1500	0 - 35	5
	TSD 3000	3000	0 - 35	8
	TSD 5000	5000	0 - 40	16
	TSD 7500	7500	0 - 40	19.5

Lifting and Girder Clamps

Rail Lifting Clamps type CR

For handling rail sections.

	Model	WLL (kg)	Weight (kg)
	CR 1000	1000	13
	CR 2000	2000	13

Pile Pitching Clamp type CP (fitted with 15 metres of rope)

These clamps are designed specifically for pitching sheet steel piling and have the advantage that a rope is fitted for easy release from ground level.

	Model	WLL (kg)	Throat Depth (mm)	Jaw Width (mm)	Pin Ø (mm)	Weight (kg)
	CP 2	2000	228	20	20	19
	CP 3	3000	228	26	30	23
	CP 5	5000	228	35	30	33

Pile Pulling Clamp type PP

The pile pulling clamp is designed to pull out driven piles. It is extremely difficult to determine the forces required to pull out a driven pile, contractors should take extra care not to exceed the WLL of the clamp.

	Model	WLL (kg)	Jaw Capacity (mm)	Throat Depth (mm)	Weight (kg)
	PP 3	3000	0 - 16	147	12
	PP 8	8000	0 - 30	194	28
	PP 12	12000	0 - 30	190	52

Screwlok Clamp type SC92 with shackle as shown, also available without shackle

Screwlok clamps are designed to fit the flanges of RSJ's and UB's as a semi-permanent lifting point.

	Model	WLL (kg)	Beam Width (mm)	Weight (kg)
	SC92-1	1000	75 - 210	5.0
	SC92-2	2000	75 - 210	6.0
	SC92-3	3000	100 - 270	8.0
	SC92-3L	3000	75 - 305	9.0
	SC92-5	5000	100 - 270	10.0
	SC92-5L	5000	75 - 305	12.0
	SC92-10	10000	75 - 305	19.0

Round Stock Grab type TRu

Scissor type grab ideal for handling round materials such as bar or tube.

	Model	WLL (kg)	Pipe Ø (mm)	Weight (kg)
	TRu 100	100	50 - 150	3.9
	TRu 500	500	35 - 200	13.6
	TRu 1000	1000	35 - 200	13.6
	TRu 1500	1500	80 - 300	27.0
	TRu 3000	3000	80 - 300	49.0

Lifting and Girder Clamps

Border Stone Lifter – type LSH

Easy clamping and release by turning the handle

Capacity (kg)	Contact Surface	Stone Thickness (mm)	Coating	Weight (kg)
80	Rubber Lined	80	Galvanised	2.5
80	Rubber Lined	60 - 120	Galvanised	3.0

Stone Clamp – type SZ

Ideal for concrete stones and plates. Large clamping range.

Capacity (kg)	Clamping Range (mm)	Weight (kg)
250	0 - 500	11
250	300 - 1000	14

Stone Lifter – type SH

For kerb stones (including curved), stones and boulders. With rubber coating or tips (3 pieces are needed).

Capacity (kg)	Clamping Range (mm)	Weight (kg)
200	0 - 400	9

Flat Clamps – type FZ

Lightweight clamp with a narrow jaw suitable for nearly all materials.

Capacity (kg)	Clamping Range (mm)	Jaw Surface	Weight (kg)
800	0 - 60	Rubber Coated	6

Block Clamps – type STZ

Lightweight clamp ideal for concrete and natural stones. Clamp adjusts automatically to material thickness.

Capacity (kg)	Jaw Surface	Clamping Range (mm)	Web Length (mm)	Weight (kg)
500	Serrated	40 - 120	250	8
500	Rubber Lined	30 - 110	250	8
1000	Serrated	100 - 225	250	14
1000	Rubber Lined	90 - 215	250	14

Drum Lifting and Turning

Drum Clamp type DC

	Model	WLL (tonnes)	Weight (kg)
	DC500	500	1.2

Designed to lift steel drums (with or without a lid) either singly or as a pair suspended from a 2-leg sling. The clamp is opened by pressing down on the hook ring.

Drum Clamp type DCV

	Model	WLL (tonnes)	Weight (kg)
	DCV500	500	1.2

Designed to lift steel drums vertically (with or without a lid). The clamp automatically grips the rim of the drum when the hook ring is lifted.

Fork Mounted Drum Grips – also available for plastic drums

	Model	WLL (kg)	No. Of Drums	Drum Size (litres)	Fork Spread (mm)	Max. Fork Size (mm)
	FDH-1-110	250	1	110	450	140 x 55
	FDH-1	500	1	210	560	140 x 55
	FDH-1-1000	1000	1	210	550	140 x 55
	FDH-2	1000	2	210	880	140 x 55

Fork Mounted Drum Rotators – also available with sideways rotation

	Model	Capacity (kg)	Operation	Girdle	Drum Size
	DTR-1 DS	360	Handle	Twin Harness	210
	DTR-2 DS	360	Chain	Twin Harness	210
	DTR-1 SC	360	Handle	Single Clamp	210
	DTR-2 SC	360	Chain	Single Clamp	210
	DTR-1 110	360	Handle	Single Harness	110
	DTR-2 110	360	Chain	Single Harness	110

Drum Manipulator - Horizontal/Vertical and Vice Versa

	Model	Capacity kg	Max. Fork Size mm	Fork Spread mm	Drum Size
	DM - 3 tine	400	140 x 50	567	210
	DM - 4 tine	400	140 x 50	567	210

Designed to manipulate Steel and Plastic drums

Safety Harnesses

We provide a comprehensive range of safety harnesses, lanyards and accessories to keep you safe when working at a height and in confined spaces.

Our safety harnesses are manufactured in accordance with EN361. Please note that the capacity of our standard range has been increased from 100 to 150 kg to comply to CNB/P/11.062 and CNB/P/11.060.

This fall arrest PPE is tested to stop the fall of a weight of 150 kg (weight of person with their equipment) with a lower impact 600daN – tested to ALL European standards.



If a fall arrest device only meets EN360, EN353-2 or EN355 without any additional specifications, it can only be used for weights up to 100 kg.



HT31
Rear D

Multi-purpose harness with five adjustment points and a sub pelvic strap



HT22
Front + Rear D

Multi-purpose harness with five adjustment points and a sub pelvic strap



HT54
Side (2) + Rear D

Multi-purpose harness with five adjustment points and a sub pelvic strap



HT56
Side (2) + Front + Rear D

Multi-purpose harness with five adjustment points and a sub pelvic strap



HT22R
Evac + Front + Rear D

Rescue harness with evacuation strap for vertical recovery



HT Ladytrac
Rear D

Designed for women with five adjustment points, automatic buckles and leg straps

Anchor Points

We offer a variety of alternative anchor points to the webbing sling suitable for man riding applications as follows:

Weight Anchor

	Weights (kg)	<p>The Mobifor weight anchor is a fast and easy to install anchor point made up of 16 x 22 kg weights that are positioned on 4 steel arms connected at the centre by a joining plate equipped with a rotary anchor point and energy dissipater. Designed for terrace roofs with a slope of less than 5 degrees.</p>
	16 x 22	

Roll Beam

	Flange Width (mm)	<p>The Roll Beam enables the creation of a mobile anchor point on an R.S.J. and to work in safety while retaining a wide freedom of movement. Travels on the lower flange.</p>
	58 - 220	

Roll Clamp

	Flange Width (mm)	<p>The Roll Clamp enables the creation of a mobile anchor point on an R.S.J. and to work in safety while retaining a wide freedom of movement. Thanks to its 4 bearing rollers the Roll Clamp follows movements around the framework on the upper or lower flange plate.</p>
	120 - 380	

Water Anchor

	Size (LxWxH)	Weight (kg)	<p>The water filled mobile anchor is compatible with a large variety of roof surfaces, can be used on pitched roofs of up to 15 degrees and has been tested to exceed the EN 795 class E standard.</p>
	1450 x 1450 x 200	8	

Vacuum Anchor

	Maximum Capacity (kg)	Power Supply (psi)	<p>The self-contained vacuum anchor system is intended to be used as an anchorage point for personnel working on aircraft or other flat smooth structures. Power can be via a compressed air cylinder or a shop air supply.</p>
	141	80 - 150	

Accessories

Lanyards - Fall Arrest and Fall Restraint - EN354 EN355

			<p>We offer fall arrest and fall restraint lanyards to form a connection between the operator's harness and an anchor point.</p> <p>Our fall arrest lanyards have a built-shock absorber to reduce the impact forces during a fall.</p> <p>A single leg lanyard is ideal for general use. A twin lanyard is used when the operator has to move between anchor points whilst still maintaining security.</p>
Single Leg Webbing Length: 1.5m & 2.0m	Single Leg Rope Length: 1.5m & 2.0m	Twin Leg Webbing Length: 1.5m & 2.0m	

Karabiners - EN362

									
Small Screwgate	Small Twistlock	Steel Twistlock	Alloy Twistlock	Scaffold Twistlock	Scaffold Twistlock	Alloy Eye	Snap Hook	Scaffold Hook	Delta Link

Retractable Lifelines - EN360 EN1496 A&B

				
Mini Web Block 1.5m, 2.0m	Fall Arrest Block 10m, 20m & 30m	Retrieval Block 20m, 30m	Temporary Lifeline (webbing or wire)	Girder Sling 0.6m, 1.0m & 1.5m

Work Positioning – EN358

<p>Ideal for use as protection for a temporary ladder or as a backup for window cleaning and façade maintenance when used in conjunction with a hoist</p>			<p>Ideal for working over the side of buildings or structures whilst maintaining comfort and concentration on the job in hand and their safety</p>	
	Rope Grab	Nylon Rope		Bosuns Chair

Accessories

						
Kit Bag	Bolt Bag	Tool Frog	Tool Hook	Mancrouche	Pole Strap	Pole Strap

Tripods

We can supply tripods that can be used for both fall arrest and lifting material loads.

Aluminium Tripod c/w Winch – Adjustable Height

	Working Load Limit (kg)	Height Underside (mm)	Weight (kg)
	500	1340 – 2300	14.3

Weight excludes the manual winch, available with a 20 or 25 metre capacity.

Easylift Tripod System

The Easylift portable tripod frame system is designed to lift a pump out from a sump in a safe manner and for the operatives to simply slide it to one side for safe inspection, repair or replacement.

To ensure the safety of the operative, a fall arrest harness can be attached to the frame, which has also been designed for single man riding.

Key Benefits:

- ✓ Easy and quick to assemble
- ✓ Conforms to the work at height regulation
- ✓ Stable construction
- ✓ Load can be moved without needing to pull the equipment from its centre of gravity
- ✓ Operatives are safe and secure
- ✓ Designed to be erected by one person



Key Design Features:

- Safe working load of 500 kg
- Load trolley
- Man riding trolley
- Spirit level built-in
- Fall arrest points
- Adjustable legs for uneven ground
- Adjustable beam length



Size Adjustment:

Height Range	1475 to 2160 mm
Width Range	2240 to 2560 mm
Depth Range	1000 to 1500 mm



Davits

Supplied in a range of capacities and designs. The davit can be permanently fixed in place or portable fitting into a range of sockets for both fall arrest and lifting material loads.

Water industry customers also use our expertise with regard to overhead travelling cranes, monorail gantry systems, jib cranes, stainless and galvanised pump chains, loose lifting tackle and site proof load testing.

Lean Over Davit

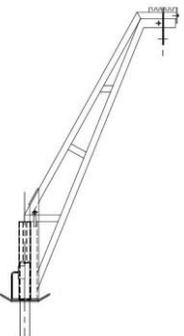
	Capacity (kg)	Reach (mm)
	500	760
	500	1000
	1000	1070
Hot Dip Galvanised		

Vertical Pole Davit

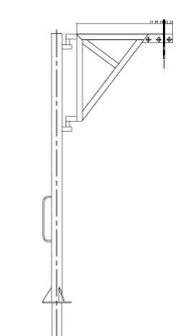
	Capacity (kg)	Reach (mm)
	500	760
	500	1000
	1000	1070
Hot Dip Galvanised		

Davit Socket Options

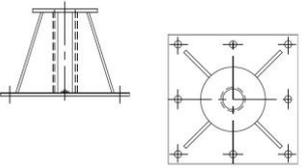
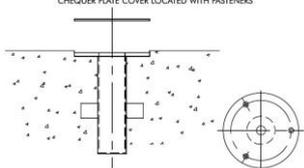
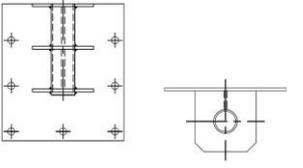
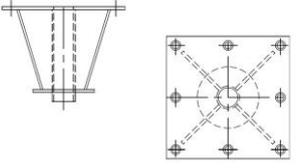
Surface Mounted	Cast-In	Wall Mounted	Inverted
			

Lifeline Systems

 Floor & roof installation	 Wall installation	 Ceiling installation	<p>We offer a range of lifeline systems that allow complete freedom of movement for working at height.</p> <p>Our systems can be used horizontally or vertically when working on roofs, overhead steelwork, fixed ladders, towers etc.</p>
--	--	---	--

Guard Rails

	<p>The Guard Rail system is formed by 1.10m posts at 1.50m centres on which concrete counterweights are placed to ensure the stability of the assembly. Fitted with 3.0m rails and kickboards.</p> <p>An ideal solution for a roof without penetrating the waterproof membrane.</p>
---	---

Load Cells



- ❑ 250 kg to 500 tonne capacities
- ❑ Rugged & weatherproof to IP 65
- ❑ High Accuracy
- ❑ Push button for tare, units, peak hold, pre-set tare, audible setpoint alarm and overload counter
- ❑ Kg, lbs, kN and tonnes
- ❑ Supplied with carry/storage case

The **LLP load cell** is used for weighing and force measuring throughout industry in factories, loading bays, construction sites and shipyards. With a shackle through each end of the link, the display gives an instant, accurate reading of the force applied and have a push button control for tare, units (kg, lbs, kN & tonnes). All sizes are machined from a single piece of high strength aluminium alloy, giving the ideal combination of lightness and strength. A remote output is fitted as standard to allow connection to our range of accessories.

Model	LLP250	LLP500	LLP1T	LLP2T5	LLP5t	LLP12T	LLP25
Capacity (kg)	250	0.50	1000	2500	5000	12000	25000
Resolution (kg)	0.05	0.2	0.5	10	10	20	50
	Kg, kN, lbs		T, kg, kN, lbs				
Safety Factor	50:1	25:1	12:1	5:1	5:1	5:1	5:1
Accuracy +/- (kg)	+/- 0.3% of applied load						
Display Type	25 mm LCD						
Operating Temp	-10 to +50 °C						
Battery Life	80 hours continuous						
Weight (kg)	1.5	1.5	1.5	1.5	2.2	3.5	5.2
Length (mm)	204	204	204	204	249	305	340
Width (mm)	101	101	101	101	101	101	110
Depth (mm)	43	43	43	43	43	47	60

Load Blocks



The Load Block is a self-contained compressive load-measuring device. The load is applied to the pressure pad on the top of the unit, and the reading is clearly shown on the large liquid crystal display (LCD). Load Blocks can be used in presses and test rigs for product or material testing, or in sets of three or four, to weigh very large structures, without the need for a crane or weigh bridge. The Load Block has a strong aluminium casing, with a recess at the front and rear to protect the display and controls from accidental damage.

Mini Weighers

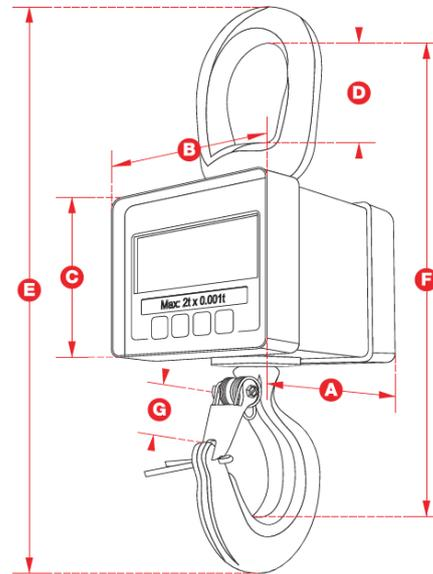

<input type="checkbox"/> Tare <input type="checkbox"/> Peak hold <input type="checkbox"/> Pre-set tare	<input type="checkbox"/> Audible setpoint alarm <input type="checkbox"/> Overload counter <input type="checkbox"/> Supplied with aluminium flight case
--	--

Maximum Load (kg)	100	250	500	1000	2000	5000
Resolution (kg)	0.05	0.1	0.2	0.5	1	1
Units	t, kg, kN and lbs					
Weight of Unit (kg)	1.5	1.5	1.5	1.5	3.1	8.7
Safety Factor	10:1	5:1	5:1	5:1	5:1	5:1
Battery	9V PP3					
Battery Life	80 hours continuous					
Display Height	25 mm LCD					
Operating Temperature	-10°C to +50°C					
Accuracy (+/- kg)	+/- 0.3% of applied load					
Protection	IP65					
Battery Life (hours)	80	80	80	80	80	80
Display Height (mm)	25	25	25	25	25	25
Dimension A (mm)	82	82	82	82	117	136
Dimension B (mm)	113	113	113	113	112	112
Dimension C (mm)	81	81	81	81	92	92
Dimension D (mm)	50	50	50	50	64	98
Dimension E (mm)	240	240	240	240	320	444
Dimension F (mm)	208	208	208	208	271	365
Dimension G (mm)	22	22	22	22	28	42

Larger capacities available, please contact us for details

Platform Scales

We offer a comprehensive range of weighing platforms manufactured to meet EU Directives to withstand the demands of continuous use in any industrial environment.

All models can be made to individual specification regarding size, capacity, strength, material, treatment, finish and protection to suit any location from dry conditions to hazardous and hostile areas.

Available manufactured in mild steel or stainless steel.

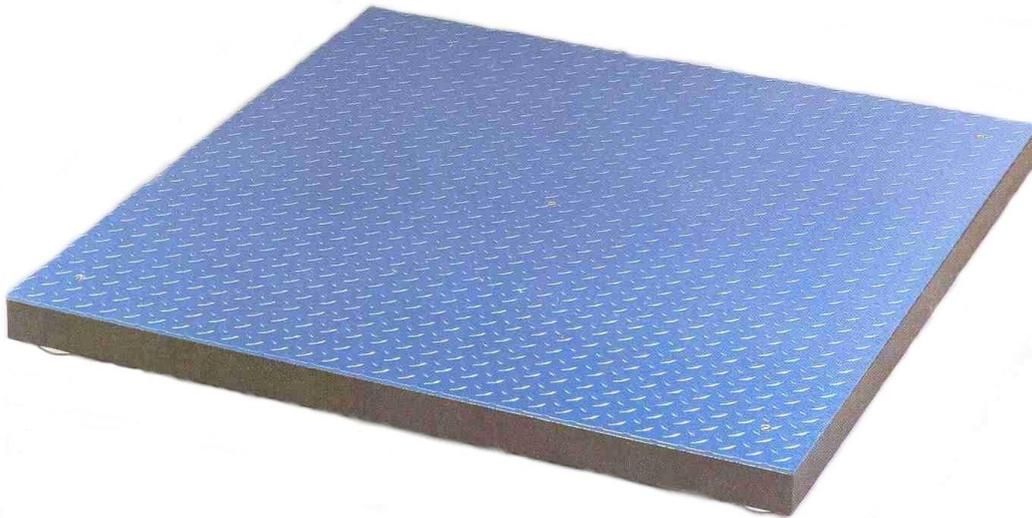

Low profile 4 load cell weighing platform for freestanding, ramped or dormant applications.

Sizes: From 600 x 600 mm to 4000 x 3000 mm

Capacities: From 300 kg to 15000 kg



A pair of portable heavy-duty weigh beams.

Size: 1200 mm long x 76 mm high

Capacities: From 500 kg to 3000 kg

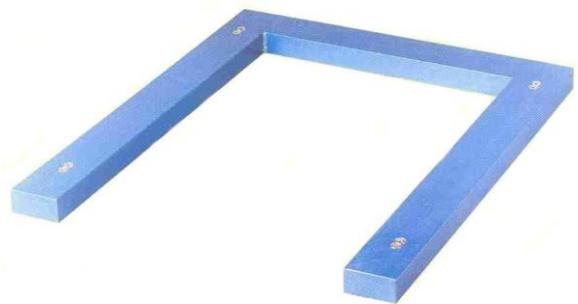

Four load cell 'U' beam pallet weiger.

Size: 1200 long x 1000 wide x 76 mm high

Capacities: From 500 kg to 3000 kg

Each weighing system will be supplied with an indicator to suit your application and a printer if required.



- Mains or battery powered
- LCD or LED display
- Scanner and printer interfaces
- Counting function
- Clock
- Tare and totals facility
- Wall or bench mount
- RS232 interface
- Intrinsically safe
- IP65

Pallet Truck Weighers

Lifting, transporting and weighing with the same equipment makes it possible to increase efficiency and make large savings.

We offer a weighing system that is factory fitted onto pallet trucks. There are different weighing systems and accessories to cover most weighing applications.

- Capacity: 2000 kg
- Lift Height: 85 - 200 mm
- Fork Length: 1150 / 1220 mm
- Width Over Forks: 570 / 700 mm
- Accuracy: +/- 0.1% of scale capacity
- Display: Can be read from any angle
- Optional: Thermal printer
- The accuracy of the weigher is not affected by the surface on which the truck operates.
- The weighing system consists of four weighing cells, each connected to the display. This ensures accurate weight indication, irrespective of load and position.
- The weigher is equipped with a rechargeable battery. The capacity is a minimum of 10 working hours per charge. The battery can be charged from a 220 volt socket.



Atex zones 1, 21 and 2, 22



Stainless steel



Powered traction

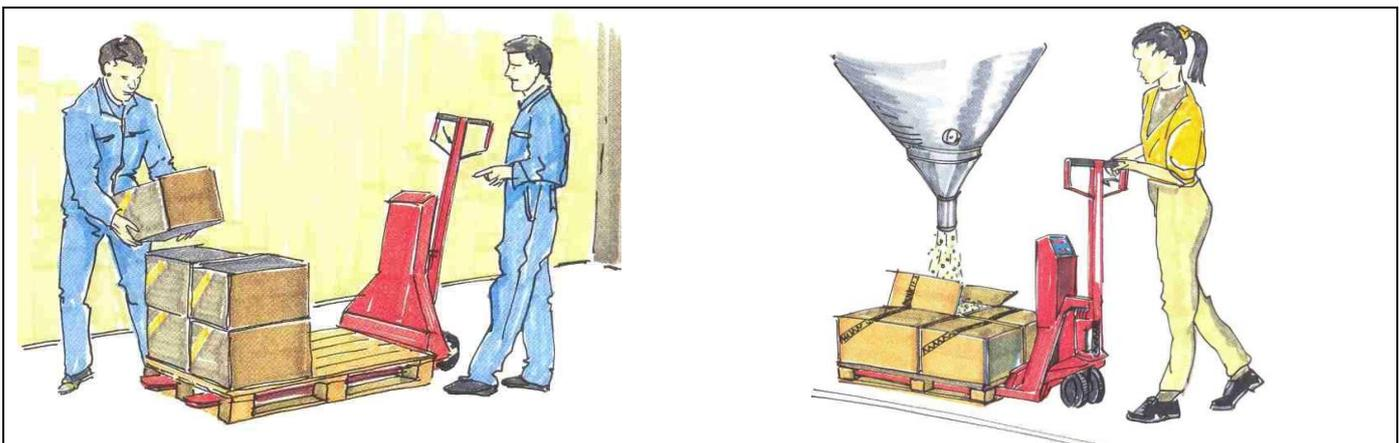

Hydraulic Jacks

JH Hydraulic Bottle Jacks

	Model	Capacity (kgs)	Closed Height (mm)	Stroke (mm)	Screw Ext. (mm)	Weight (kgs)
	JH-2	2000	181	115	50	2.7
	JH-4	4000	205	126	60	3.7
	JH-6	6000	219	130	75	4.7
	JH-8	8000	225	152	70	5.7
	JH-12	12000	240	153	80	8.0
	JH-20	20000	240	153	80	11.0
	JH-30	30000	280	180	-	22.0
	JH-50/2	50000	305	178	-	53.0

Hydraulic Claw Jacks

	Model	Claw Capacity (kgs)	Head Capacity (kgs)	Closed Height (mm)	Stroke (mm)	Weight (kgs)
	HCJ-3	3000	3000	16 / 230	130	16.4
	HCJ-6	6000	6000	22 / 267	152	23.2
	HCJ-10	10000	10000	29 / 280	130	38.2

Features include a low toe height and a large base area.

AJH/S Aluminium Hydraulic Jacks

	<p>Aluminium jacks combine light weight with a high lifting capacity. The use of high tensile aluminium alloys allows lifting capacities of up to 100 tonnes resulting in a very favourable 1.8 tonnes lifting capacity per 1 kg weight ratio.</p> <p>Capacity: 6.5 to 100 tonne without toe Capacity: 20 to 60 tonne with toe</p>
---	--

Model	Capacity Head (tonnes)	Capacity Toe (tonnes)	Stroke (mm)	Closed Height (mm)	Base Plate Size (mm)	Weight (kgs)
AJS-653	6.5	-	75	131	159 x 76	3.6
AJS-104	10	-	115	182	171 x 76	6.3
AJH-620-toe	20	8	152	280	250 x 120	67
AJH-1220-toe	20	8	305	452	250 x 120	67
AJH-630-toe	30	12	152	284	275 x 140	72
AJH-1230-toe	30	12	305	472	275 x 140	72
AJH-660-toe	60	24	152	327	340 x 190	72
AJH-1260-toe	60	24	305	533	340 x 190	72

Jacks

Hydraulic Machine Jacks

	Model	Capacity (kgs)	Stroke (mm)	Closed Toe Height (mm)	Closed Head Height (mm)	Weight (kgs)
	HMJ-50	5000	205	25	368	25
	HMJ-100	10000	230	25	420	35
	HMJ-250	25000	215	58	505	109

Can be used vertically and horizontally. Removable pump handle.

Manual Steel Jacks with Fixed Claw

Primarily used for assembly applications, to brace or support loads but can be used for almost any application. The load can be positioned on the head or the toe. Turn the operating handle to smoothly lift or lower the load up and down the rack. The load is held securely in any position.

	Model	Capacity Head (mm)	Capacity Toe (mm)	Stroke (mm)	Closed Toe Height (mm)	Closed Head Height (mm)	Weight (kgs)
	SJ1.5	1500	1050	360	70	725	13.0
	SJ3.0	3000	2100	360	70	735	20.0
	SJ5.0	5000	3500	350	80	730	27.0
	SJ10.0	10000	7000	410	85	800	43.0
	RSJ5.0	5000	3500	360	80	740	29.0

RSJ Model
High stability on uneven ground is ensured by the extra-large floor plate (e.g. gravel).

Roller Pinch Bars

Available with steel rollers, ideal for lifting, shifting and positioning of awkward loads.

	Type	RPB1500	RPB5000
	Capacity	1.5 tonnes	5 tonnes
	Lift Height	145 mm	145 mm
	O/A Length	2000 mm	2000 mm
	Roller Diameter	75 x 55 mm	70 x 54 mm
	Weight	16.5 kg	32 kg

Pumps and Cylinders



We offer a comprehensive range of hydraulic equipment and tools designed for professional operation.

Our cylinders are designed from high quality chromium-molybdenum steel and heat-treated.

They are provided with double bronze bearings on the plunger, which minimises friction between the plunger and the body during lateral loading.

To facilitate the installation of hydraulic cylinders in jigs and fixtures a metric mounting thread is supplied.



Universal Cylinders
(single and double acting)



Low Height Cylinders
(single acting with spring return)



Pull Cylinders
(single acting with spring return)



Hollow Cylinders
(single and double acting)



High Tonnage Cylinders
(double acting)



Cylinders with Safety Lock Nut
(single acting)



Hand pumps are the most common power source within the area of 'High Pressure Hydraulic Tools'. For this reason our hand pumps have been designed and equipped with many details which make the pumps very versatile and handy in every day applications including:

- Relief valve / hand wheel
- All metal design
- Carrying handle
- Pressure relief valves
- Reservoir ventilation
- Two-stage output
- Easy maintenance design
- Return oil port
- Base frame
- Pressure gauges

Hydraulic Accessories

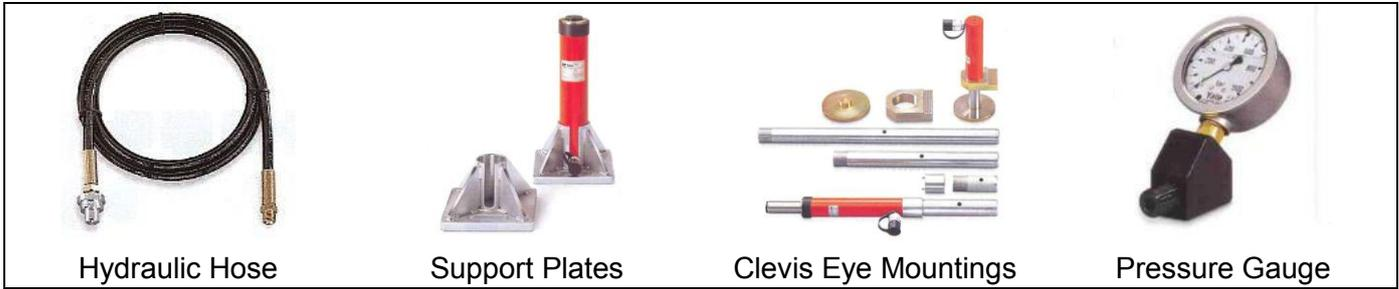

Hydraulic Hose

Support Plates

Clevis Eye Mountings

Pressure Gauge

Pumps



Mini Hand Pump

Foot Pump

Air

Electric

Manifolds and Valves

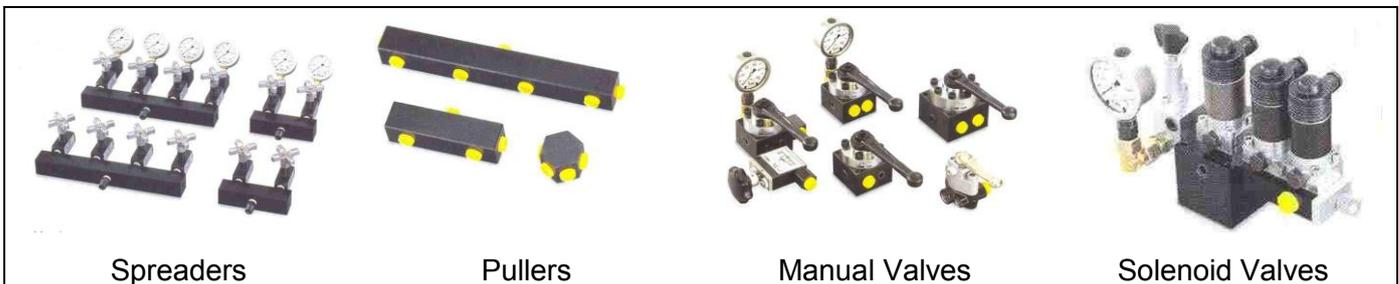

Spreaders

Pullers

Manual Valves

Solenoid Valves

Hydraulic Tools

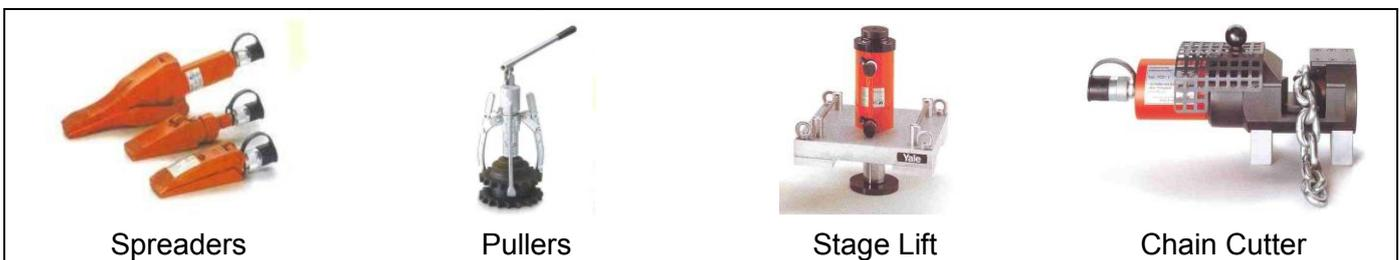

Spreaders

Pullers

Stage Lift

Chain Cutter

Maintenance Sets and Systems

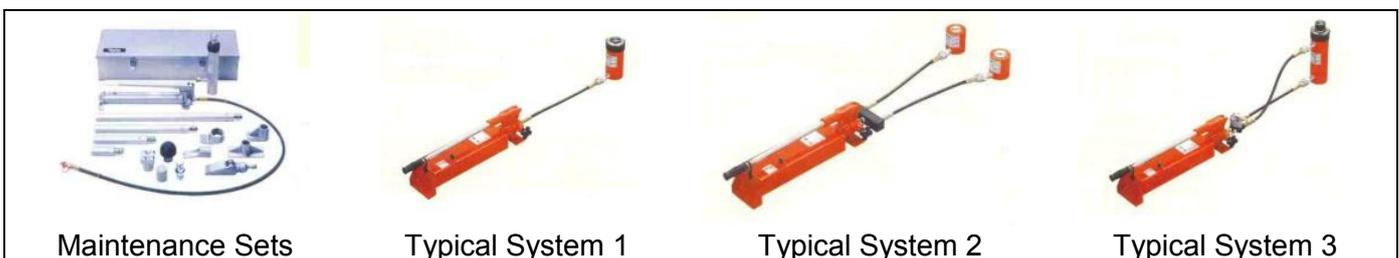

Maintenance Sets

Typical System 1

Typical System 2

Typical System 3

Pallet and Stacker Trucks



Manual Pallet Truck

Capacity: 2000 - 2500 kg
Fork Length: 600 - 3000 mm
Width Over Forks: 450, 540 and 685 mm



Electric Pallet Truck

Capacity: 1500 kg
Fork Length: 1000 and 1150 mm
Width Over Forks: 560 and 680 mm



Manual Highlift Pallet Truck

Capacity: 1000 kg
Lift Height: 800 mm
Fork Length: 1170 mm
Width Over Forks: 540 and 680 mm



Electric Highlift Pallet Truck

Capacity: 1000 kg
Lift Height: 800 mm
Fork Length: 1170 mm
Width Over Forks: 540 and 680 mm



Galvanised Steel Pallet Truck

Capacity: 2000 kg
Fork Length: 1150 mm
Width Over Forks: 540mm



Stainless Steel Pallet Truck

Capacity: 1000 kg
Fork Length: 1150 mm
Width Over Forks: 540 mm

Trucks, Scissor Lifts, Stair Climbers Section: 21

Stacker Trucks



Manual Truck

Capacity: 500 and 1000 kg
 Lift Height: up to 2050 mm
 Fork Length: 1140 mm
 Width Over Forks: 528 mm



Manual Stacker Truck

Capacity: 1000 kg
 Lift Height: up to 3000 mm
 Fork Length: 915 mm
 Width Over Forks: 210 – 800 mm adjustable



Semi-Electric Stacker Truck

Capacity: 1000 - 2000 kg
 Lift Height: up to 3300 mm
 Fork Length: 1150 mm
 Width Over Forks: 540 mm



Electric Stacker Truck

Capacity: 1000 - 2000 kg
 Lift Height: up to 3300 mm
 Fork Length: 1150 mm
 Width Over Forks: 540 mm



Specials – please contact us for any variations not shown in our catalogue



Drum Attachment



Boom Attachment



Tilt Attachment

Fork Truck Attachments

Access Platforms

Optional Extras:

- Castors
- Tool tray
- Safety harness & lanyard
- Overhead guard
- Strip light bulb holder
- Foldable design available



Model	Entry Position	Platform Size (mm)	No. Persons	Max. Fork Size (mm)	Fork Spread (mm)	Weight (kg)
WP-SPG	Front gate	1000 x 1000	1	150 x 50	794	105
WP-SP	Lift up front bar	800 x 800	1	150 x 50	794	75
WP-STD	N/A	1000 x 1220	2	150 x 50	794	110
WP-GATED	Left side gate	1000 x 1220	2	150 x 50	794	120
WP-STD Mk4	Lift up front bar	1000 x 1000	2	150 x 50	794	110

Fork Tine Hooks

Used singularly, they quickly transform your forklift truck into a crane.

Model	Capacity (kg)	Min. Tine Width (mm)	Max. Tine Width (mm)	Weight (kg)
TZH1.5/150	1500	100	150	8.5
TZH3.0/150	3000	100	150	12
TZH5.0/150	5000	100	150	16
TZH5.0/200	5000	150	200	16
TZH10.0/200	10000	150	200	43



Fork Mounted Hooks

The most cost effective way of safely slinging a load underneath both forks of your forklift truck. Simply adjust the width across your forks, slide the hook onto the forks and clamp anywhere along their length.

Model	Capacity (kg)	Max. Fork Size (mm)	Fork Spread (mm)	Weight (kg)
FMHA-1.0	1000	140 x 50	676	19
FMHA-1.0-BP	1000	180 x 90	758	22
FMHA-2.0	2000	140 x 50	676	23
FMHA-2.0 BP	2000	180 x 90	758	23
FMHA-3.0	3000	140 x 50	676	26
FMHA-3.0 BP	3000	180 x 90	758	24
FMHA-4.0	4000	180 x 90	794	30
FMHA-4.0 BP	4000	180 x 90	794	30
FMHA-5.0	5000	180 x 90	794	30
FMHA-5.0 BP	5000	180 x 90	795	30



Fork Truck Attachments

Fork Mounted Jib - Fixed

An inexpensive jib which gives longer reach capabilities for picking up a product, which are difficult to palletise or for handling loads, which are hard to access.



Model	Truck Capacity (kg)	Max. Reach (mm)	Max. Fork Size (mm)	Fork Spread (mm)	Weight (kg)
FMJ 500-0.8	1000	1750	125 x 50	496	110
FMJ 500-1.0	1300	1750	125 x 50	496	120
FMJ 500-1.3	1500	1750	125 x 50	496	130
FMJ 500 1.8	2000	1750	125 x 50	496	135
FMJ 500-2.2	2500	1750	125 x 50	496	150
FMJ 500-2.7	3000	1750	125 x 50	546	155
FMJ 500-3.1	35000	1750	125 x 50	546	157
FMJ 500-3.5	4000	1750	125 x 50	546	160
FMJ 500-4.4	5000	1750	125 x 50	546	180

Also available with big pockets to suit a larger fork section, please contact us for details.

Fork Mounted Jib - Telescopic

An inexpensive jib which gives longer reach capabilities for picking up a product, which are difficult to palletise or for handling loads, which are hard to access. Supplied with two swivel hooks.



Model	Capacity (kg)	Max. Reach (mm)	Max. Fork Size (mm)	Fork Spread (mm)	Weight (kg)
FMX 500-1.8	2000	1000 - 3000	125 x 50	496	117
FMX 500-2.2	2500	1000 - 3000	125 x 50	496	122
FMX 500-2.7	3000	1000 - 3000	125 x 50	546	210
FMX 500-3.1	3500	1000 - 3000	125 x 50	546	225
FMX 500-3.5	4000	1000 - 3000	125 x 50	546	236
FMX 500-4.4	5000	1000 - 3000	125 x 50	546	246

Also available with big pockets to suit a larger fork section, please contact us for details.

Fork Mounted Jib - Articulated

An alternative jib design enables loads to be handled at variable heights. This telescopic jib is supplied with two swivel hooks and can be adjusted to 45 degrees in 15 degree increments.



Model	Capacity (kg)	Max. Reach (mm)	Max. Fork Size (mm)	Fork Spread (mm)	Weight (kg)
FMXA 500-2.2	2500	1000 - 3000	125 x 50	496	282
FMXA 500-2.7	3000	1000 - 3000	150 x 50	546	330
FMXA 500-3.1	3500	1000 - 3000	150 x 50	546	332
FMXA 500-3.5	4000	1000 - 3000	150 x 50	546	332

Trucks, Scissor Lifts, Stair Climbers Section: 21

Fork Truck Attachments

Forks - please contact us for a quotation

	Carriage Class	Truck Capacity (kg)	Carriage Depth (mm)	Ground Clearance Under Carriage (when fully lowered) (mm)
	1A 1B	up to 999	331	76 114
	2A 2B	1000 - 2500	407	76 152
	3A 3B	2501 - 4999	508	76 203
	4A 4B	5000 - 6500	635	127 254

Fork Extensions

A range of fork extensions designed to offer occasional loan reach and stabilising capabilities. Supplied with integral retaining bar and full formed and profiled toe section.

	Model	Extension Length (mm)	Truck Fork Size (L x W) (mm)
	FEX 1200	1200	102 x 45 / 112 x 45 / 137 x 50 / 163 x 60 / 213 x 75
	FEX 1350	1350	112 x 45 / 137 x 50 / 163 x 60 / 213 x 75
	FEX 1500	1500	112 x 45 / 137 x 50 / 163 x 60 / 213 x 75
	FEX 1650	1650	112 x 45 / 137 x 50 / 163 x 60 / 213 x 75
	FEX 1800	1800	112 x 45 / 137 x 50 / 163 x 60 / 213 x 75
	FEX 2000	2000	112 x 45 / 137 x 50 / 163 x 60 / 213 x 75
	FEX 2250	2250	213 x 75

Caution: Max. extension length must be no greater than 150% of the fork length.

Tipping Skips - Roll Forward



Options:

- Braked castors
- Lifting lugs
- Fork clamps
- Drain taps
- Lid
- Stainless steel

Model	Capacity		Weight (kg)	Load Centre (mm)	Overall Size (LxWxH) (mm)	Fork Spread (mm)	Internal Height (mm)
	(m ³)	(kg)					
RF S25L	0.25	1000	100	595	1148 x 900 x 678	890	547
RF 40L	0.40	1000	110	679	1410 x 900 x 781	890	547
RF 80L	0.80	1000	145	735	1480 x 900 x 834	890	600
RF 120L	1.20	1250	170	835	1710 x 900 x 985	890	750
RF 160L	1.60	1500	180	835	1710 x 900 x 985	890	750
RFS 200L	2.00	1500	225	835	1710 x 900 x 985	890	750

Also Available:

- | | | |
|--|-----------------------------------|---|
| <input type="checkbox"/> Fork Heel and Load Protectors | <input type="checkbox"/> Booms | <input type="checkbox"/> Drum Lifting (p73) |
| <input type="checkbox"/> Gas Bottle Handler | <input type="checkbox"/> Sweepers | <input type="checkbox"/> Magnets |

Trucks, Scissor Lifts, Stair Climbers Section: 21

Scissor Lifts – Static



Standard

Model	Capacity (kg)	Operation	Platform Size (mm)	Closed Height (mm)	Raised Height (mm)	Lifting Speed (mm/sec)
AXX4-8T	400	Push Button	800 x 600	200	1000	25
AX5-8/6	500	Push Button	1200 x 800	200	1000	42
AX10-8/6	1000	Push Button	1200 x 800	200	1000	42
AX10-8/8	1000	Push Button	1200 x 1000	200	1000	42
AX20-8/6	2000	Push Button	1350 x 800	220	1020	32

Low Profile

Model	Capacity (kg)	Operation	Platform Size (mm)	Closed Height (mm)	Raised Height (mm)	Lifting Speed (mm/sec)
MX5-8/10	500	Push Button	1350 x 1050	80	880	42
MX10-8/8	1000	Push Button	1350 x 800	80	880	42
MX10-8/10	1000	Push Button	1350 x 1050	80	880	42
MX12-9/8	1200	Push Button	1400 x 800	80	880	42
MX18-9/8	1800	Push Button	1400 x 800	95	895	32

Other designs and sizes are available on request.

Scissor Lifts - Mobile



Single Scissor

Model	Capacity (kg)	Operation	Platform Size (mm)	Overall Size (mm)	Closed Height (mm)	Raised Height (mm)	Weight (kg)
BS15	150	Foot Pump	700 x 450	950 x 450	255	760	41
BS25	250	Foot Pump	830 x 500	1050 x 500	315	910	78
BS50	500	Foot Pump	1010 x 520	1185 x 520	430	1000	118
BS75	750	Foot Pump	1010 x 520	1260 x 520	435	1000	120
BS100	1000	Foot Pump	1010 x 520	1260 x 520	445	950	137

Double Scissor

Model	Capacity (kg)	Operation	Platform Size (mm)	Overall Size (mm)	Closed Height (mm)	Raised Height (mm)	Weight (kg)
BS30D	300	Foot Pump	1010 x 520	1260 x 520	435	1585	150
BS80D	800	Foot Pump	1010 x 520	1260 x 520	470	1410	165
ES30D	300	Electric	1010 x 520	1260 x 520	495	1600	183
ES80D	800	Electric	1010 x 520	1260 x 520	510	1460	176

Trucks, Scissor Lifts, Stair Climbers Section: 21

Stair Climbers - Manual

	Stairclimber with Skids	Aluminium Stairclimber with Skids
		
Max. Load: Max. Load: Size (HxWxD): Toe Plate (WxD): Wheels:	60 kg - on stairs 150 kg - as a sack truck 1180 x 480 x 600 mm 460 x 395 mm (fixed) 3 x 150 mm 3-star system	60 kg - on stairs 150 kg - as a sack truck 1180 x 500 x 550 mm 460 x 395 mm (fixed) 3 x 150 mm 3-star system
	Telescopic Stairclimber with Skids	Wide Stairclimber
		
Max. Load: Max. Load: Size (HxWxD): Toe Plate (WxD): Toe Plate (WxD): Wheels:	50 kg - on stairs 150 kg - as a sack truck 1230 x 500 x 680 mm 460 x 395 mm (fixed) - 3 x 150 mm 3-star system	50 kg - on stairs 150 kg - as a sack truck 1160 x 605 x 795 mm 410 x 200 mm (fixed) 395 x 460 mm (hinged) 3 x 160 mm 3-star system

Stair Climbers - Powered

Lightweight and fast sack truck and powered stair climber combined in one machine.

	Ergo / Uni / Fold	SAL 110	SAL 140
	Capacity	110 kg	140 kg
	Maximum climb speed	48 steps / min	35 steps / min
	Weight excluding battery	16 kg	20 kg
	Maximum step height	210 mm	210 mm
	Overall height - fixed frame (Uni, Ergo)	1570 mm	1570 mm
	Overall height - foldable frame (Fold)	1000 mm	1000 mm
	Clearance	484 mm	484 mm
	Overall width	484 x 275 mm	484 x 275 mm
	Hinged toe standard	275 x 236 mm	275 x 236 mm
	Battery capacity (max. load) approx.	260 steps	220 steps
	Battery capacity (half load) approx.	350 steps	300 steps

Metal Roller Skates

This range of caterpillar roller skates are a cost effective, safe and easy method of moving heavy and bulky loads in any direction. They operate by the action of an endless roller chain revolving around the centre member of the body. The load is borne by the rollers and the body providing an extremely low coefficient of friction of usually between 3% and 7% of the total load.

Supplied in a set of 4 and can be used on their own or together with steering accessories supplied.



Turntables can be located on the top of the skate when it is desired to have complete control over the steering of the load, for example when manoeuvring in confined spaces.

Stabilisers are used in conjunction with the turntables to compensate for the height difference on skates with turntables and those without.

Spacer Bars are used to tie two skates together to keep them parallel under movement.

Rubber Pads for the load to rest on to facilitate even weight distribution and compensate for slight floor unevenness. It also eliminates metal to metal contact.

Steering Handles are supplied and are for steering purposes only, when the skates are fitted with turntables. They are not for pulling or pushing the load.

Systems are supplied in their own high quality, lockable, steel boxes with nylon castors. These robust carrying cases help keep all the set together and prevent loss of individual components.

Model	System Capacity (tonnes)	Skate Length (mm)	Skate Width (mm)	Skate Height (mm)	Turntable Height (mm)	Roller Width (mm)	Roller Diameter (mm)	System Weight (kg)
SC 20	20	205	102	62	41	51	18	50
SC 50	30	215	112	74	41	58	24	58
SC 60	60	268	130	92	48	66	30	92

Other special heavy-duty skates are available on request.

Nylon Roller Skates



Features:

- Three-point load carrying system.
- Safe, stable and eliminating the risk of one skate moving from beneath the load.
- Manufactured from Spheroidal Graphite Iron.
- Immensely strong material, powder coated prior to assembly. The material allows system sizes to be kept to a minimum.
- Special nylon wheels machined from solid not from tube.
- The material is hard enough to give a low rolling resistance and pliable enough to prevent damage to painted or sealed floors.
- Innovative wheel and bearing design.
- Two ball bearing assemblies are fitted to each wheel. The relatively narrow wheel design allows more bearing support over any given width. Narrow wheels reduce scuffing and greatly improve rolling resistance when negotiating turns.
- Systems assembled without the use of tools.
- By retaining the pivot pins with a series of robust spring clips enables each model to be assembled and dismantled by hand. Not even a screwdriver is required to dismantle units to a convenient size for easy transportation.
- Unique Steerman designed turntables.
- Special cast nylon, which was developed because of its strength and lightweight, is then CNC machined from solid. Only 20% of the weight of the steel equivalent it has many superior qualities including anti-slip and impact resistance. The design of the nylon turntables gives protection to the thrust bearings should dynamic shock occur. Turntables are supported on a full size thrust bearing, which prevents loads being imposed outside the support area of the bearing. This configuration gives easy steering action when turning.

Specification:

Model	Capacity	Total No. of Wheels	Overall Height	Rear Adjustment	Net Weight
SX10 *	10 tonnes	16 @ 82 mm Ø	102 mm	252 - 1200 mm	54 kg
SX20 *	20 tonnes	32 @ 82 mm Ø	102 mm	480 - 1500 mm	76 kg
SX30 *	30 tonnes	48 @ 82 mm Ø	110 mm	720 - 1500 mm	136 kg
S60	60 tonnes	48 @ 115 mm Ø	170 mm	800 - 2000 mm	302 kg
S100	100 tonnes	48 @ 150 mm Ø	210 mm	990 - 2000 mm	525 kg

* Also available in ATEX Explosion Proof specification

Air Skates

Air skates literally float heavy loads on a virtually frictionless film of air. Reduced friction and omni directional movement allow the operator to precisely place and align the load in a limited workspace. The low profile of the load module requires less than 70 mm clearance and will not damage the floors and expensive reinforcement is usually not necessary. Because we only use basic pneumatic components such as air regulators and hoses, our products are not only reliable but will operate in most environments.

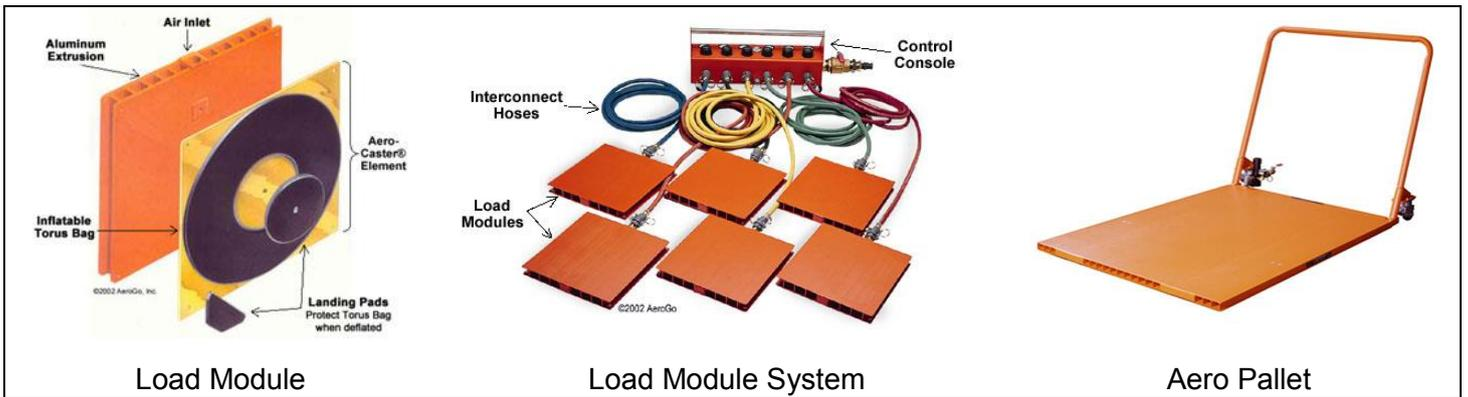

Easy Movers

Used in pairs for effortless lifting and moving of awkward loads. Simply place 1 unit at each end of the load, raise the load off the floor, secure the unit connecting straps and move away. The SC/600 is supplied with a manually operated winch to lift the load whilst the SC/1800 is supplied with a manually operated hydraulic ram to lift the load.



Model	Capacity (kg)	Operation	Lifting Height (mm)	Lifting Plate (mm)	Wheels (mm)	Weight (kg)
SC/600	600	Manual	300	225 x 120	125 Ø	25 / pair
SC/1800A	1800	Hydraulic	100	600 x 60	150 Ø	80 / pair
SC/1800B	1800	Hydraulic	250	600 x 60	150 Ø	86 / pair

Gravity Roller Systems

A simple and economic method of material movement supplied with a variety of roller heights, diameters and pitches to suit your application.

Features Include:

- Adjustable height stands
- Turntables
- Ball rollers
- Hinged gates
- Curves
- Junctions
- Mobile sections
- Integrated scissor lifts
- Roller protective coatings

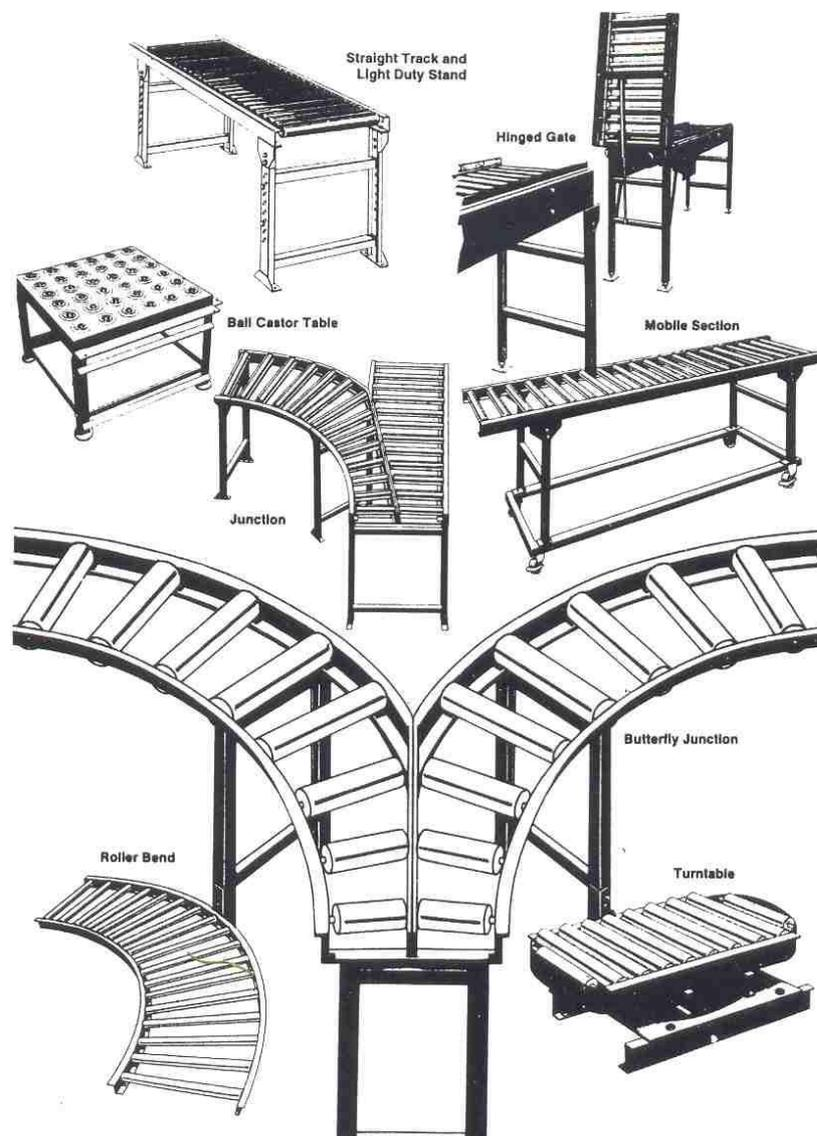

Powered Roller Systems

We can also offer powered roller conveyor systems manufactured to your specification.

Reel Lifting and Turning Systems

Lemm equipment is built for individual applications in the paper, label, film and foil producing industries. It is designed to grip and rotate through 90 degrees sensitive, costly material in reels with no loss of value through faulty handling. Moving materials in reels is a job where slip-ups can be expensive. Damage to edges and outer layers increase costs. Incorrect handling often causes accidents involving personal injury - that's why Lemm designs incorporate safety as a top priority. Lemm equipment is normally suspended from an electric chain hoist on a jib or overhead crane but is now available mounted onto a mobile battery lift truck.



RH & RHA

These units are for picking up reels with the core vertical. There is no rotation facility on these models. The RH model has a manually operated core gripper whilst the RHA model has an automatic operation of the core gripper. Optional reel turner clamps are available for telescoping materials.

The maximum safe working load is 2000 kg.



RWM

This unit has a manually operated expanding core gripper to grip the reel and a manually operated pivot to rotate the load through 90 degrees.

The maximum safe working load is 150 kg.



RWK I/A

This unit is used for lifting reels with materials, which will telescope if lifted by the core alone. It pneumatically grips the reel between a mandrel in the core and a gripper on the outside diameter of the reel and also uses the pneumatics to rotate the reel through 90 degrees. The mandrel in the core can also be used to grip the core if required.

The maximum safe working load is 300 kg.

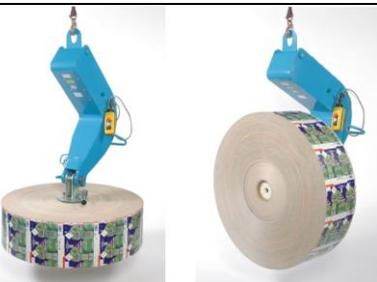

RWS

This unit has a manually operated expanding core gripper to grip the reel and a hydraulically operated pivot to rotate the load through 90 degrees.

The maximum safe working load is 2000 kg.



Mobile Reel Turners

These units offers mobile reel lifting and turning systems to rotate the reel through 90 degrees using either:

- i) A spindle in the core of the reel (as shown)
- ii) A clamp on the outside diameter of the reel

The reel turner is incorporated into a mobile stacker truck offering a variety of lift heights with manual or powered travel.

The maximum safe working load is 1000 kg.

Festoon and Conductor Systems

Festoon Cable Systems

These components enable the user to build complete festoon cable supply systems for trolleys, cranes and monorails and for automatic charging and processing machines. It can also be used for easy movement of electric and pneumatic portable tools suspended by means of balancing devices (also supplied by us).

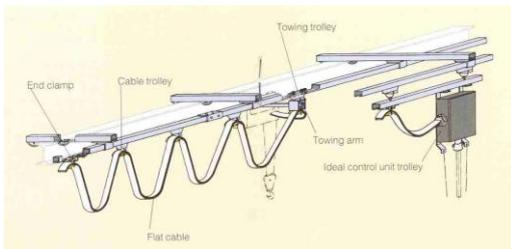

- Light-weight robust components
- High rigidity of the hollow section rail
- Low dead weight
- High resistance to wear
- Electro-galvanised for good resistance to corrosion
- Plastic or steel travel wheels mounted on anti-friction bearings

Conductor Systems

Suitable for heavy-duty electrical supply on cranes and monorails.

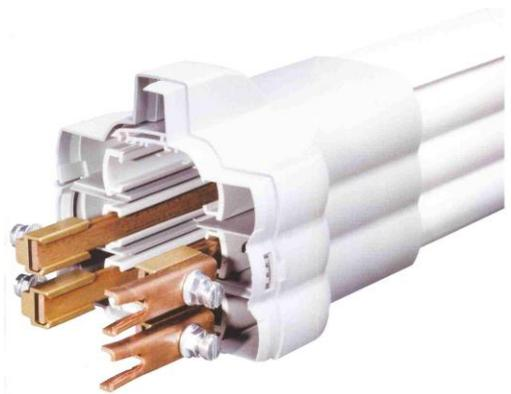

- Easy installation with pre-assembled connectors
- Expansion accommodated at every joint
- The system can be inspected at every joint
- Fast, simple replacement of straight sections
- Compact dimensions
- High rigidity
- Low dead weight
- Protected power cables integrated in the current collector trolley
- Pre-assembled sliding contacts connected and fixed with just one screw

Energy Chain Systems



- Ideal for use with various types of motion and travels
- Guidance of sensitive bus and data cables, as well as LWL, using the same techniques as with electric, gas, air and liquid hose guidance
- Long service life under very high loads and demanding requirements
- Smooth operation in a full range of environments and climates
- Supplied with cable and guide troughs

Ladders and Steps

Step Ladders

	Treads	Platform Height (mm)	Overall Size-In Use (HxWxD) (mm)	Folded Height (mm)	Weight (kg)
	3	616	1244 x 470 x 723	1426	3.8
	4	828	1461 x 496 x 869	1656	4.4
	5	1041	1677 x 525 x 1016	1887	5.0
	6	1253	1893 x 552 x 1163	2117	6.1
	7	1465	2110 x 580 x 1309	2348	7.2
	8	1677	2326 x 607 x 1456	2529	8.4

Step Ladders with Hand Rails

	Treads	Platform Height (mm)	Overall Size-In Use (HxWxD) (mm)	Folded Height (mm)	Weight (kg)
	5	1160	1800 x 490 x 1040	2050	8.0
	6	1390	2030 x 510 x 1210	2300	9.0
	8	1850	2490 x 570 x 1550	2800	11.0
	10	2300	2940 x 620 x 1870	3300	13.5
	12	2770	3410 x 670 x 2250	3800	16.0

Extension Ladders

	Treads	Closed Height (mm)	Extended Length (mm)	Overall Height Λ Position (mm)	Weight (kg)
	3 x 8	2400	5000	2300	15.0
	3 x 10	3000	6300	2900	20.0
	3 x 12	3500	8000	3400	26.0
	3 x 14	4100	10250	4000	32.0

Mobile Steps

	Treads	Handrail	Platform Height (mm)	Overall Size (H x W x D) (mm)	Weight (kg)
	2	No	500	580 x 560 x 575	8.0
	2	1	500	960 x 560 x 575	9.0
	2	2	500	960 x 560 x 575	10.0
	3	2	750	1460 x 560 x 725	13.0
	4	2	1000	1710 x 560 x 875	16.0
	5	2	1250	1960 x 610 x 1025	21.0

We have only shown a small selection of ladders on this page so if we haven't shown what you are looking for please contact us.

Warehouse Steps

Heavy Duty Vantage Mobile Steps

Platform Size (W x D): 460 x 540 mm

	No of Treads	Platform Height (mm)	Overall Size (HxWxD) (mm)	Weight (Kg)
	3	690	1690 x 700 x 890	37
	4	920	1920 x 700 x 1100	41
	5	1150	2150 x 700 x 1200	45
	6	1380	2380 x 700 x 1370	49
	7	1610	2610 x 700 x 1530	53
	8	1840	2840 x 700 x 1700	57
	9	2070	3070 x 700 x 1860	65
	10	2300	3300 x 700 x 2020	70
	11	2530	3530 x 800 x 2190	76
	12	2760	3760 x 800 x 2360	82
	13	2990	3990 x 1150 x 2520	89
	14	3220	4220 x 1230 x 2690	92
	15	3450	4450 x 1230 x 2850	95
	16	3680	4680 x 1230 x 2920	101
	17	3910	4910 x 1400 x 3180	108
	18	4140	5140 x 1400 x 3350	117

Standard Mobile Steps

Platform Size (W x D): 400 x 300 mm

	No of Treads	Handrails	Platform Height (mm)	Overall Size (HxWxD) (mm)	Weight (Kg)
	2	No	500	580 x 540 x 510	10
	2	1	500	1230 x 540 x 510	11
	2	2	500	1230 x 540 x 510	12
	3	2	750	1480 x 540 x 720	17
	4	2	1000	1730 x 550 x 870	20
	5	2	1250	1980 x 665 x 1020	25
	6	2	1500	2230 x 750 x 1170	28

Easy Slope Mobile Steps - 48° incline for safe & easy use

Platform Size (W x D): 800 x 1200 mm

	No of Treads	Platform Height (mm)	Overall Size (HxWxD) (mm)	Weight (Kg)
	3	690	1690 x 950 x 1826	74
	4	920	1920 x 950 x 2033	82
	5	1150	2150 x 950 x 2240	90
	6	1380	2380 x 950 x 2447	98

We have shown a small selection on this page so please contact us if we haven't shown what you are looking for.

Manhole Lifting Devices

Manhole Lifting Pins – Pivoting Latch

Manhole lifting pins are usually used in pairs with a 2-leg chain sling and offer a fast and safe way of lifting concrete manhole rings. The latch pivots to allow it to be inserted through the hole in the manhole ring. When it is released it automatically rotates to lock the pin in place due to its off centre pivot point.

	Capacity / Pin (kg)	Pin Diameter (mm)
	750	25
	1000	32
	1500	35
	2000	38

Manhole Lifting Pins – Washer and Pin

	Capacity (kg)	Pin Diameter (mm)	Max. Wall Thickness (mm)
	1500	30	150

Road Gully Grab – type SAG

A grab for base, cylindrical and conical drain assemblies.

			Capacity (kg)	Clamping Range (mm)	Weight (kg)
			150	460 / 560	12

Internal Manhole Housing Grab – type RG

Designed to lift manhole housing and covers with vents.

		Capacity (kg)	Housing Diameter (mm)	Weight (kg)
		200	610 / 625	12

Manhole Housing Grab – type RG

Designed to lift manhole housing and covers.

			Capacity (kg)	Housing Diameter (mm)	Weight (kg)
			200	750 / 785	15
Complete with a set of hooks type A and B					

Manhole Lifting Devices

Manhole Clamp – type SZ

Ideal for the transport and laying of manholes. Clamp adjusts automatically to wall thickness.

	Capacity (kg)	Clamps	Jaw Surface	Clamping Range (mm)	Manhole I/D (mm)	Web Length (mm)	Weight (kg)
	1000	2	Steel	40 - 120	800 - 2000	1450	16
	2000	2	Steel	60 - 180	800 - 2000	1450	28

	Capacity (kg)	Clamps	Jaw Surface	Clamping Range (mm)	Manhole I/D (mm)	Web Length (mm)	Weight (kg)
	1500	3	Steel	40 - 120	800 - 2000	1450	28
	1500	3	Steel	40 - 120	800 - 2800	2050	27
	3000	3	Steel	60 - 180	800 - 2000	1450	40
	3000	3	Steel	60 - 180	800 - 2800	2050	41
4000	4	Steel	60 - 180	800 - 2500	1450	55	

	Capacity (kg)	Clamps	Jaw Surface	Clamping Range (mm)	Manhole I/D (mm)	Chain Length (mm)	Weight (kg)
	1500	3	Steel	40 - 120	800 - 2000	1450	33
	3000	3	Steel	60 - 180	800 - 2000	1450	45
3000	3	Steel	60 - 180	800 - 3000	2200	47	

Manhole Grabs – type RSV

A rubber coated jaws are needed for smooth, painted or coated manholes.

	Capacity (kg)	Clamps	Jaw Surface	Clamping Range (mm)	Manhole I/D (mm)	Chain Length (mm)	Weight (kg)
	1500	3	Steel	40 - 120	400 - 2000	1500	31
	1500	3	Steel	40 - 120	400 - 3000	2000	33
	1500	3	Rubber Coat	0 - 70	400 - 2000	1500	34
	3000	3	Steel	50 - 180	400 - 2000	1600	53
	3000	3	Steel	50 - 180	400 - 3000	2200	57
	3000	3	Rubber Coat	0 - 130	400 - 2000	1600	55
	3000	3	Steel	90 - 230	400 - 2000	1600	54
	3000	3	Steel	90 - 230	400 - 3000	2200	58
	3000	3	Rubber Coat	50 - 180	400 - 2000	1600	56
	1000	2	Steel	40 - 120	-	800	10
	2000	2	Steel	50 - 180	-	800	17
	4000	4	Steel	50 - 180	1000 - 2500	1600	82

Manhole Cover Lifter – type KH

Designed to lift manhole covers using a hydraulic cylinder. Easy to dismantle and transport in a car boot.

	Capacity (kg)	Lifting Height (mm)	Hook Distance	Total Width (mm)	Weight (kg)
	1000	250	260 - 980	1200	30

Complete with a set of hooks type A and B



Hook A



Hook B

Carrymate Panel and Door Lifters

Ideal for lifting and moving a variety of materials:

- Steel
- Glass
- Plywood
- Stone
- Plasterboard
- PVC
- Doors

The Carrymate is a manually operated self-adjusting clamp system designed to be used in pairs to lift a variety of panels. They are fitted with replaceable non-slip grips that also prevent damage to the carried load.

Each clamp can lift up to 100 kg

Single Handle Grips

		<p>Sizes:</p> <ol style="list-style-type: none">1) 0 – 80 mm2) 40 – 120 mm3) 80 – 160 mm <p>Sold in pairs</p>
---	--	---

Double Handle Grips

		<p>Sizes:</p> <ol style="list-style-type: none">1) 0 – 80 mm2) 40 – 120 mm3) 80 – 160 mm <p>Sold in pairs</p>
---	---	---

Portman Door Lifter

		<p>Lifts, lowers and swivels to enable smooth foot control when fitting a door. Available in two sizes:</p> <p>XL – 120 kg XXL – 200 kg</p>
--	---	---