

RANGE OF PRODUCTS · ESSENTIAL COMPONENT PARTS



Flat-bag filter



Evaporative cooler



Flat-tube heat exchanger



Fixed bed/Mobile bed adsorber

WE, THE COMPANY LUEHR FILTER GMBH & CO. KG

- ⊙ have been a worldwide acting company for more than 70 years
- ⊙ have practical experience in nearly all fields of industry
- ⊙ develop process-related solutions for each separate case of application
- ⊙ offer complete project handling from engineering to plant operation



Particle separation



Chemical sorption



Adsorption

WE BUILD PLANTS FOR

- ⊙ particle separation from air and/or flue gases
- ⊙ dry or semi-dry chemisorption of crude gases such as HF, HCl, SO_x
- ⊙ adsorption e.g. of PCDD/PCDF and heavy metals such as Hg

if necessary with integration of measures for heat recovery.

OUR CORE ACTIVITY IS

the forward-looking and innovative development of our products and procedures for the separation of particulate and gaseous substances from the air and/or process gas.

**MORE THAN 70 YEARS OF WORK EXPERIENCE GATHERED
FROM THE CONSTRUCTION OF AIR POLLUTION CONTROL PLANTS**

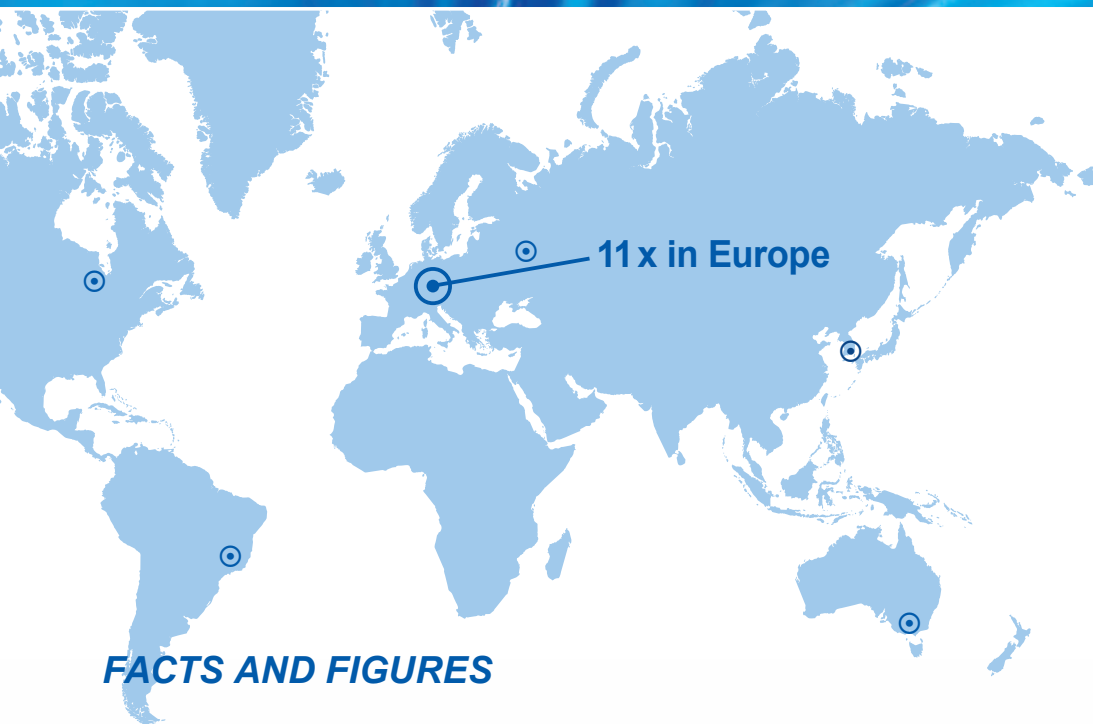

FACTS AND FIGURES

Founded: 1938

Employees: approx. 300, thereof 140 working in production

Turnover: approx. 70 Mio. € (without subsidiaries and holdings)

Head office: Stadthagen

Subsidiaries: in Austria, Great Britain and Italy

Companies with holdings: **M.G.F. – Gutsche & Co. GmbH-Betriebs-KG** in Fulda (i. a. manufacture of needle felts for filtration)
EWK-Umwelttechnik GmbH in Kaiserslautern (i. a. sales of dry and wet electrostatic precipitators and catalyst technology)
LUHR FILTER PTY. LTD. – Australia – Melbourne – Rowville
BLUE BIRD CO. LTD. – Korea – Seoul
LUHR FILTER Polska sp.z o.o. – Poland – Wrocław
Kuttner LLC – USA – Port Washington

International representations: in Benelux, Brazil, Finland, France, Norway, Russia, Spain and Switzerland



Head office



Works



Works

THE COMPANY ...

LUEHR FILTER is a worldwide, family-owned company with more than 70 years of practical experience in the development and construction of "Plants for air pollution control". Our range of products includes all component parts, from the gas take-off up to the stack. Engineering, maintenance, and support services complete our package. Our worldwide references, which include installations in incineration plants for power generation, the iron and steel industry, the non-ferrous metal industry, the cement/lime/gypsum industry, the gravel and asphalt industry, and the chemical industry attest to our service capabilities.



Flat-bag production



Sheet metal forming



Pre-assembly



Control panel construction

PRODUCTION FACILITIES

We are producing relevant core components of our product range in our own production facilities in Stadthagen. With this vertical range of manufacture we consistently achieve high levels of quality, flexibility, and delivery reliability to our customers.

PROJECT REALISATION

LUEHR FILTER offers you turnkey, professional project realisation; from the project study, through project handling and services on site, to support services after commissioning of the plant. More than 80 highly qualified members of our technical team are across multiple departments, like process technology, project management, mechanical and electrical project handling, commissioning and service. In our office we are using up-to-date software such as AUTOCAD, Inventor, ELCAD, EPLAN, and MS Project, as well as different programming languages for the plant control. In addition, we are using CFD (computational fluid dynamics) for the optimisation of flow procedures together with external institutions.

... AND THE RANGE OF PRODUCTS AND SERVICES

The range of products comprises all necessary component parts for the solution of an application from the gas and particle collection up to the stack. Different, self-developed sorption procedures are available for the separation of gaseous substances.

- ⊙ Flat-bag filter
- ⊙ Flat-tube heat exchanger
- ⊙ Evaporative cooler
- ⊙ Mobile bed adsorber
- ⊙ Sorption procedures (Information in brochure "Sorption processes for the separation of gaseous substances")

The range of products is completed by:

- | | |
|-------------------------------------|---|
| ⊙ Additive powder injection devices | ⊙ Component parts for gas and particle capture |
| ⊙ Fans | ⊙ Sound-absorbing measures |
| ⊙ Dry hydrator for CaO | ⊙ Pneumatic transport devices |
| ⊙ Gravel bed filters | ⊙ Disposal stations |
| ⊙ Cyclones | ⊙ Vacuum cleaning plants |
| ⊙ Ducting and stacks | ⊙ Modernisation of existing filtration plants |
| ⊙ Control panels | ⊙ Dry and wet electrostatic precipitators (through holding EWK) |

Important component parts are supplied from our production facilities in Stadthagen.

Our service activities comprise all services beginning at the project inception through the After-Sales service.



Flat-bag filter



Flat-tube heat exchanger



Evaporative cooler



Sorption procedures



FLAT-BAG FILTER



Flat-bag filter



Flat-bag filter

The constructive features of the horizontally or vertically installed flat-bag filter elements, particularly in combination with the different – off line – cleaning systems included in our range of products offer, among other things, the following advantages:

- ⊙ the reliable observance of requested residual particle contents in the clean gas
- ⊙ exceptionally long filter fabric service lives
- ⊙ low maintenance
- ⊙ low space requirement

Flat-bag filters are used for gas volumes from 1,000 m³/h up to more than 1,000,000 m³/h.

FLAT-BAG FILTER WITH HORIZONTALLY INSTALLED FLAT-BAG FILTER ELEMENTS

General design

The filter housing is divided into crude gas and clean gas chambers by means of perforated plates. The flat-bag filter elements, each consisting of flat-bag and support cage, are mounted from the clean gas side. The flat-bag filter elements

are precisely fixed in the housing. They are fitted in the holes of the perforated plate, secured without the use of screws and provide a perfect seal against dust leaks. The crude gas flow through the textile filter material is from outside to inside, and the particles are retained on the outside.

Schematic view without cleaning device

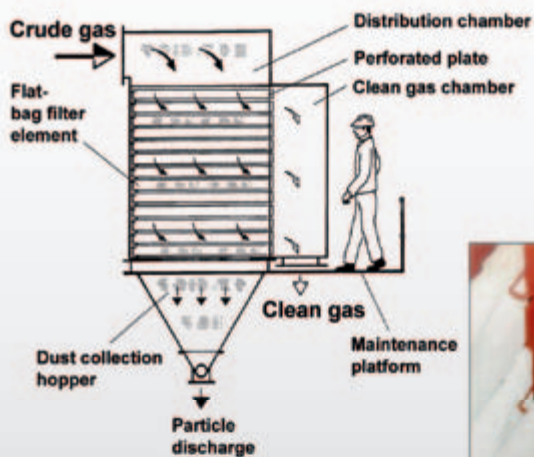

Flat-bag filter element

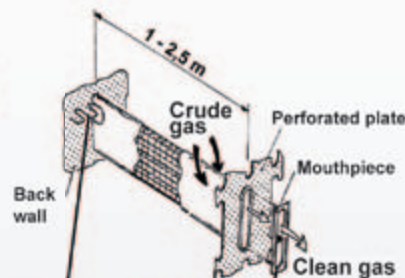

Holder at back wall

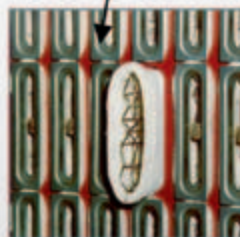

Mouthpieces and perforated plate

CLEANING SYSTEMS

Compressed air – on line – cleaning

The clean gas chamber is provided with vertically installed, easy to remove compressed air injectors, arranged in front of each bag row. Compressed air and clean gas as secondary gas are injected sequentially into two adjacent bag rows by means of injectors, designed in accordance with aerodynamic principles. The bag rows are cleaned in pairs by a brief pulse of jet air, injected into the bags contrary to the filtration flow, thus removing the particle cake from the fabric filter.

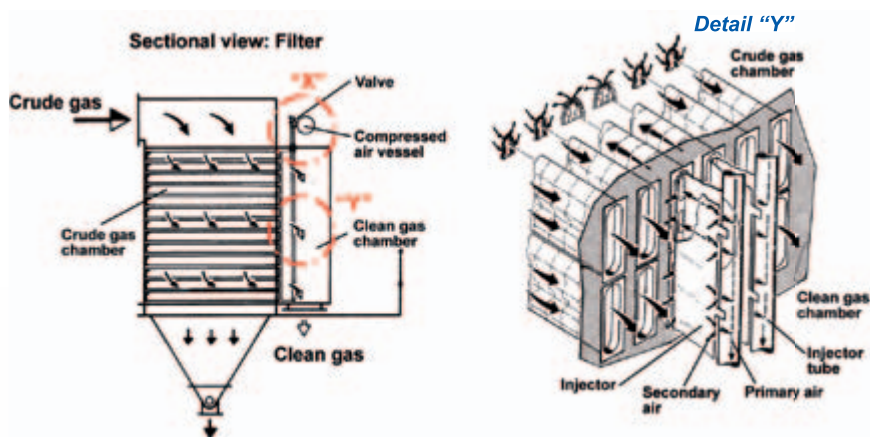

Compressed air – on line – cleaning



Detail "X"

Compartmentalised compressed air – off line – cleaning

At this cleaning process, the filter housing clean gas chamber is divided into several chambers. Each chamber is connected with the clean gas collective channel and can be isolated. At the beginning of the cleaning process in one chamber, the corresponding isolation damper on the clean gas side will be closed. The flat-bags are cleaned during interrupted filtration process by means of compressed air. After the cleaning process, the chamber remains isolated until the filter bags of the next chamber have to be cleaned.

The cleaning of bags of one chamber by means of compressed air takes place in the same way as described for the compressed air – on line – cleaning.



Compartmentalised compressed air – off line – cleaning

Online maintenance

The complete crude and clean gas area of the filter housing can be divided into chambers on request, thus offering the possibility to isolate separate chambers for inspection and/or repair while the other chambers are still available for the filtration process.

CLEANING SYSTEMS

Travelling compressed air – off line – cleaning

The cleaning of the flat-bag rows takes place sequentially in steps by means of a cleaning device, travelling within the clean gas chamber and provided with compressed air feeding and injector tubes. The cleaning device covers three vertical filter bag rows, the middle of them being cleaned with a brief, about 0.5 sec., pulse of compressed air and clean gas as secondary gas. A lip seal along the carriage travel serves as reliable sealing, proved in continuous operation.



Detail "X"

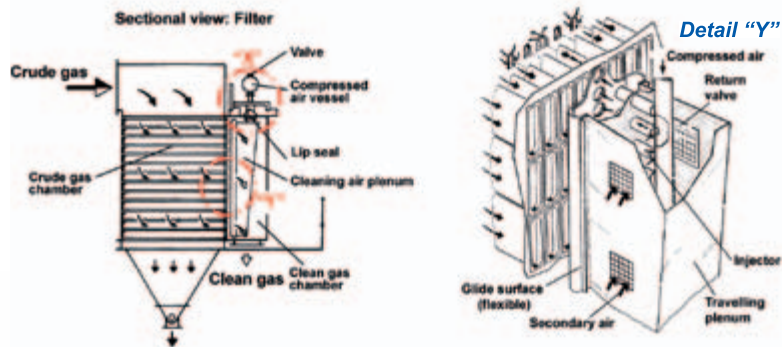

Travelling medium pressure – off line – cleaning

The cleaning of the flat-bag rows takes place sequentially in steps by means of a cleaning device, travelling within the clean gas chamber. The cleaning air is injected into one flat-bag row by means of a medium pressure fan, while the two flat-bag rows adjacent to the row being cleaned are not charged by the crude gas during the cleaning process. A lip seal along the carriage travel serves as reliable sealing, proved in continuous operation. This cleaning system does not require any compressed air.

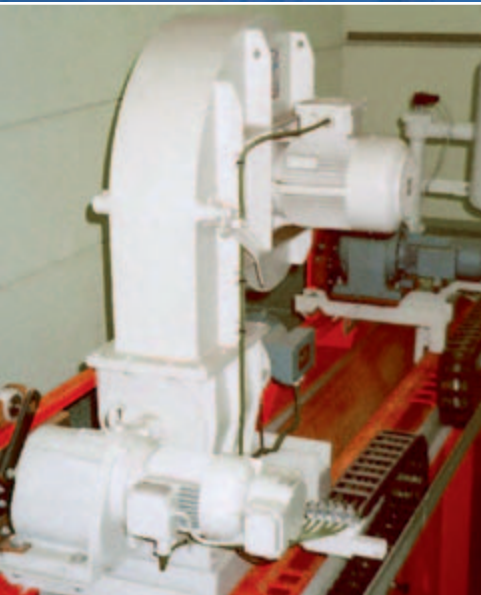

Detail "Z"

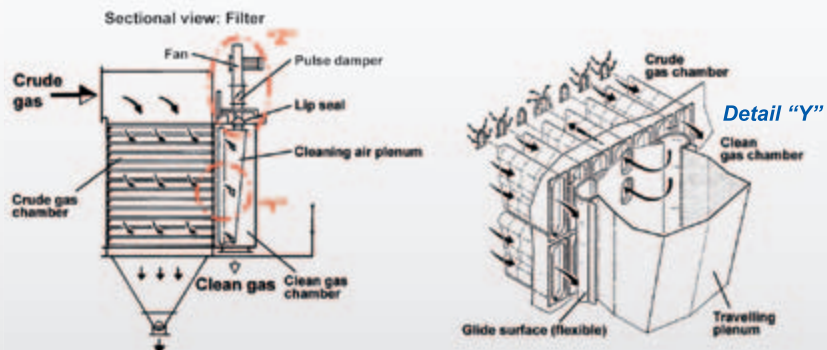

FLAT-BAG FILTER

FLAT-BAG FILTER WITH VERTICALLY INSTALLED FLAT-BAG FILTER ELEMENTS

The filter housing is divided into crude gas and clean gas chambers by means of perforated plates. The flat-bag filter elements, each consisting of flat-bag and support cage, are mounted from the clean gas side. The flat-bag filter elements are precisely fitted in the housing. They are fixed in the holes of the perforated plate, secured without the use of screws, and provide a perfect seal against dust leaks. The crude gas flow through the textile filter material is from outside to inside, and the particles are retained on the outside. This filter type is normally provided with a compressed air – on line – cleaning system. The advantages of a flat-bag filter with horizontally installed filter elements can only partially be used in case of vertical installation of filter elements.

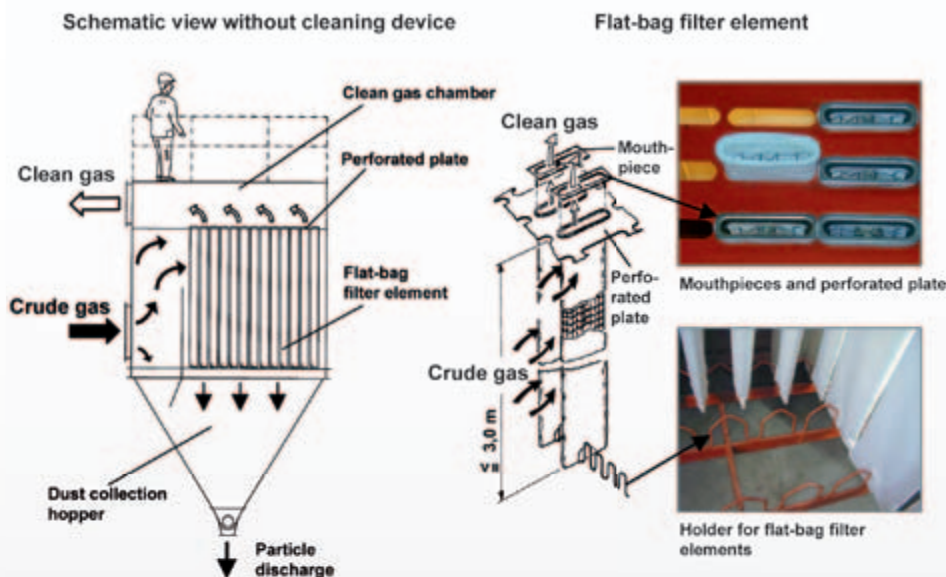

Flat-bag filter



Flat-bag filter



Flat-bag filter



View into the penthouse of a flat-bag filter with:

- ⊙ vertically installed flat-bag filter elements
- ⊙ compressed air – on line – cleaning system
- ⊙ partitioning in chambers for online maintenance



FLAT-BAG FILTER ...

ADVANTAGEOUS FEATURES OF FLAT-BAG FILTERS

Flat-bag filters are designed to achieve low residual concentration of particulate in the clean gas and maintain long filter fabric service life. The long fabric service life, compared to more conventional round vertical bag-filters, is due to low mechanical stress to which the fabric is subjected. Some corresponding aspects are mentioned below.



Support cage of flat-bag filter element

Support cage construction

The support cages have a small wire mesh (approx. 25 x 25 mm) thus achieving, across the entire fabric surface, an even distribution of the differential pressure forces acting on the filter bags. The smaller the mesh, the lower the load is on the textile filter fabric near the wires.

Length of flat-bag filter elements

The filter element length is limited to 2.5 m for the horizontal installation, and to 3.0 for the vertical installation. In comparison to other types of construction, this length limitation requires the installation of proportionally more filter elements for a filter surface of the same size; however, it offers considerable advantages:

- ⊙ Better distribution of the cleaning energy on the complete filter surface
- ⊙ The filter housings can be transported to construction site with the filter elements already installed
- ⊙ The individual filter elements are easy to handle
- ⊙ No divided support cages are used

Cleaning systems

In comparison to – on line – cleaning procedures, – off line – working procedures offer some advantages:

- ⊙ Lower mechanical stress of filter fabric
- ⊙ Lower low residual concentration of particulate in the clean gas due to the avoidance of “rug tapping effect”
- ⊙ Higher cleaning effectiveness
- ⊙ Longer cleaning cycle

The medium pressure and compressed air – off line – cleaning systems with a travelling cleaning device in the clean gas chamber, are favourably priced flat-bag filter types.



Transport



Erection

... ADVANTAGEOUS FEATURES

They benefit from the advantages of the – off line – cleaning systems, without having to accept the less favourable complex construction of the compartmentalised – off line – cleaning system.

Filter inlet to the filter elements

An important condition for achieving long cleaning cycles and low stress of the filter fabric is the preferably undisturbed descent of the separated particles within the filter housing. When using one compartment filters, a crude gas inlet from above is preferred. With a crude gas inlet from below, or diagonally from below, the particle agglomerate separated from the filter fabric can only descend if its descent velocity is higher than the gas inlet in counter flow. Since the descent velocity of particle agglomerates of about 200 µm totals only about 1 m/sec., it is evident that one compartment filters should be exclusively provided with a crude gas inlet from above. This will avoid an undesired and uncontrolled redeposit of even the finest of particles. This advantage holds true only in flat-bag filters with horizontally installed flat-bag filter elements.



*Travelling compressed air
– off line – cleaning*



*Travelling compressed air
– off line – cleaning*



*Travelling medium pressure
– off line – cleaning*

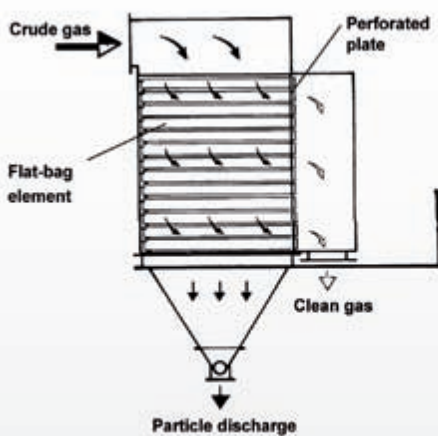

Crude gas inlet 100 % from above
Downstream principle favours the falling down of particles into the collection hopper.

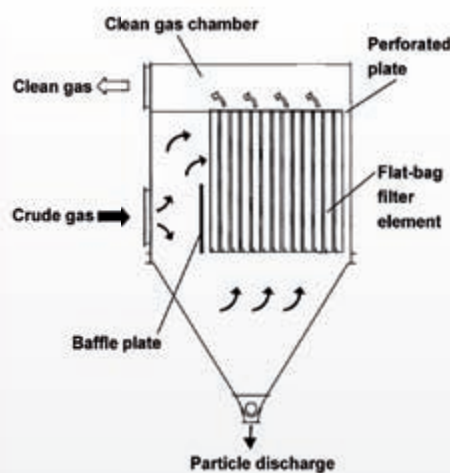

Crude gas inlet from above and below
The partial inlet from below hinders the falling down of particularly the fine particles into the collection hopper.

FLAT-TUBE HEAT EXCHANGER



Flat-tube heat exchanger



Flat-tube heat exchanger



Flat-tube heat exchanger

Flat-tube heat exchangers – if necessary – are installed upstream of flat-bag filters to reduce the temperature of the gases to be cleaned to a temperature admissible for the filter fabric, or to adjust the optimum process temperature. During development of this heat exchanger, special importance was attached to the objective to achieve a reliable continuous operation, combined with a constant cooling of gases; even in case of high particle loads in the gas and/or a strongly adhesive character of these particles. Occasional manual cleaning proved to be unnecessary for maintaining the heat transfer. We take additional measures, if necessary, to ensure a trouble-free continuous operation of the flat-tube heat exchanger and exceptionally long service lives of cooling tubes.

- ⊙ Utilisation of a mechanically working cooling area cleaning device in case of presence of particles with adhesive features
- ⊙ Avoidance of temperatures below the dew point by using pre-heated cooling air (cooling air recirculation)
- ⊙ Prevention of temperatures below the acid dew point by injection of additive powders in the flue gas flow to be cooled upstream of the heat exchanger

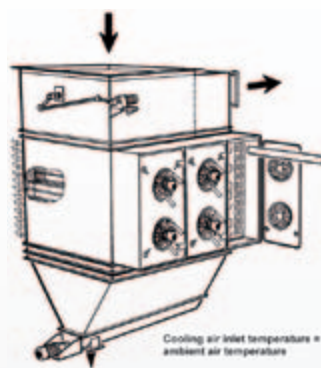

Types

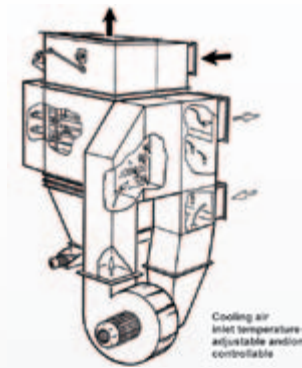

Flat-tube heat exchanger without cooling air recirculation



Flat-tube heat exchanger with cooling air recirculation

CONSTRUCTION

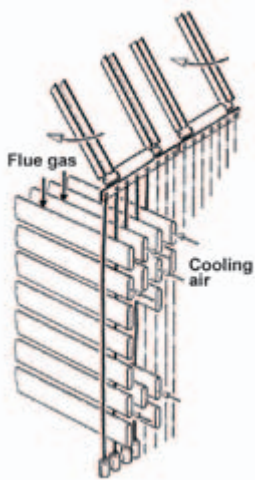

The cooling takes place through indirect heat exchange of the gas to be cooled, and the aspirated ambient air or cooler. The gas to be cooled flows between the external surfaces of the horizontally located cooling tubes, either from the top to the bottom or from the bottom to the top. Some of the heat is transferred to the cooling air flowing inside of the cooling tubes. By recirculating some of the cooling air and, if necessary, additional additive powder injection into the gas, it is, if essential, ensured that the water and/or acid dew point near the walls charged by the gas will not be undershot. Corrosion and caking are avoided.

If the particles tend to be adhesive, the heat exchanger will be provided with a cleaning device, running in automatic operation during heat exchanger charging. By moving chains slowly to and fro between the flat-tube rows, the thickness of the particle layer deposited on the flat-tubes will be limited.

The length of horizontally installed flat-tube cooling elements is limited to max. 2,800 mm. They are installed in the cooler housing in such a way that they can each be exchanged separately.

The cooling tubes are installed in perforated plates located on both sides of the cooler housing. Special sealings between the flat-tubes and the perforated plates help to avoid leakage between the gas to be cooled and the cooling air. The sealings are designed so that temperature-related expansions will be compensated without any problems.



View on chain cleaning device



View on chain cleaning device



Perforated plate with flat-tube cooling elements

HEAT RECOVERY/HEAT TRANSFER

There are different types of heat recovery available, on request, e.g. in the form of hot water generation. The gas cleaned in the filter located downstream of the heat exchanger can be used as cooling gas, if necessary. This form of heat transfer around a fabric filter is used e.g. if there is a catalyst located downstream of the fabric filter, to reduce the NO_x .

EVAPORATIVE COOLER

During the evaporative cooling, liquid droplets are injected into the gas flow by means of spraying lances, reducing the heat during the evaporation process. A reliable cooler operation requires the complete evaporation of droplets at low temperature fluctuations at the cooler outlet.

The main design features for a safe evaporative cooler are:

- ⊙ Spraying technology
- ⊙ Consistent gas flow through the evaporation zone
- ⊙ Control technology

In most of the cases two-component nozzles (water and compressed air) are used for the spraying. As an alternative, one-component nozzles can be used, requiring conveying pumps with a definitely higher pressure rise.

If necessary, a sorption agent (e.g. limestone slurry or sodium hydroxide solution) can be injected into the evaporative cooler together with water and compressed air, for the separation of acid crude gas pollutants and to protect against corrosion. Using sorption agents, the size of evaporative cooler/spray absorber has to be adapted accordingly due to the longer evaporation times of injected liquids.

LUEHR FILTER is working in cooperation with well known specialists on the design, construction and execution of evaporative coolers.



Evaporative cooler



Water/compressed air control station



Spraying lances in mounted condition

FIXED BED/MOBILE BED ADSORBER

LUEHR fixed bed/mobile bed adsorbers are used for the adsorption of gaseous pollutants such as

- ⊙ PCDD/PCDF
 - ⊙ heavy metals, i.e. mercury
 - ⊙ hydrocarbon compounds
 - ⊙ gaseous inorganic substances such as HCl, SO₂, H₂S
- at grainy activated carbon/-coke or other coarse-grained sorbents.

Advantageous features of LUEHR fixed bed/mobile bed adsorbers:

- ⊙ Simple plant technology with low maintenance
- ⊙ Low investment and operating costs
- ⊙ Achieve low residual concentration of particulate in the clean gas at good utilisation of adsorbing agent, i.e. due to a consistent inlet flow distribution over the complete gravel bed area, and a uniform discharge of adsorbent over the whole adsorber area
- ⊙ Low pressure loss, i.e. due to uniform flow distribution across the entire bed area
- ⊙ Depending on the application, selection of a variable bed thickness between approx. 500 and 1,000 mm
- ⊙ High reliability i.e. due to a consistent flow across and through the entire bed material of adsorber

Sizes

- ⊙ Volume flows up to max. 10,000 Am³/h in one unit
- ⊙ Volume flows of 10,000 Am³/h up to approx. 40,000 Am³/h by parallel arrangement of several single units

Criteria for application

- ⊙ Particle contents in the gas flow upstream adsorber < 5 mg/Nm³. To ensure that an early, partial replacement of adsorbent material does not become necessary (as a result of an excessive pressure drop, but only after saturation of adsorber material), it might be necessary to install a LUEHR flat-bag filter for the particle separation upstream of a mobile bed adsorber.
- ⊙ Gas temperatures < 150 °C

Handling of sorbent material

- ⊙ The replacement of granular sorbent takes place during disconnected admission after saturation of material. The adsorber material is partly, or completely, discharged via collection hopper and manual damper, by means of manual operation of discharge grid. The new material is filled from above out of adequate transport containers (e.g. Big Bag) and evenly distributed over the entire bed area (Fixed bed adsorber).
- ⊙ On request, the partial or complete discharge of saturated material, as well as the filling with new adsorbent can be automated (Mobile bed adsorber).



Fixed bed adsorber



Fixed bed adsorber



Mobile bed adsorber

*Find the contact person responsible for your area on
www.LUEHR-FILTER.de*



Enzer Straße 26
31655 Stadthagen | GERMANY
Phone: +49 5721 708-0
Fax: +49 5721 708-214
E-Mail: info@luehr-filter.de
Internet: www.luehr-filter.de