

YOU'LL NEVER BE BETTER PROTECTED

# Safety Eyebolt Solutions



- CE APPROVED TO PPE DIRECTIVE
- SUITABLE FOR USE IN TENSION AND IN SHEAR
- COMPREHENSIVE RANGE OF EYEBOLTS AND ACCESSORIES



## The Removable Safety Solution for Fall Protection

The **KEE I-BOLT** range offers a comprehensive selection of Class A1 safety anchors. The **RINGANKA** portfolio comprises three different lengths of eyebolt suitable for use in a range of materials; brick, concrete, masonry and steel. However, it is important that the correct eyebolt is used to suit the material and that the positioning is determined by a competent person. **KEYANKA** is a removable eyebolt which is unobtrusive where visual presentation is important. Each of the products has been independently tested at the National Engineering Laboratory and is CE approved to meet the PPE Directive.

As a leading supplier of fall protection solutions, **Kee Safety** offers a range of collective and personal protection products including **KEEGUARD**, **KEE DOME**, **KEE ANCHOR** and **KEE ROOFPOINT**. Our technical team can offer practical assistance in all aspects of design, installation and compliance with relevant standards for each of the products.



### Keyanka

A KEE SAFETY PRODUCT

## Why you need KEYANKA



By using a correctly installed and tested **I-BOLT** system you can ensure the health and safety of anybody who works in an environment which calls for safe and tested fall protection. The **KEYANKA** safety eyebolt offers a removable unobtrusive solution to traditional eyebolts for use in more prestigious buildings. The permanently installed grade 316 stainless steel anchor socket is concealed by a flush fitting white plastic cover, which blends in with most interior designs.



Equipped with the **KEYANKA** eyebolt at the end of their lanyard, the operator uses a simple 'key' action with sprung locking movement, to provide a fast and safe attachment. The eyebolt is able to rotate 180° whilst still attached to the socket to provide the best orientation in event of a fall arrest situation, and can only be removed by five simple, separate but deliberate, sequential movements.

## 'Kee' Features of KEYANKA

- Independently tested at N.E.L. (National Engineering Laboratory, East Kilbride, N.B. 0320)
- Conforms to CLASS A1 EN 795, BS 7883 & ISO 14567
- CE Approved to PPE Directive
- Removable Eyebolt
- Produced from Grade 316 Stainless Steel
- Flush fitting white plastic cover to blend in with most interior designs
- Spring loaded locking action
- Variety of fixing options including concrete, brick, steelwork and cavity walls
- Optional Stainless Steel or Brass Cap

### KEYANKA in Steelwork

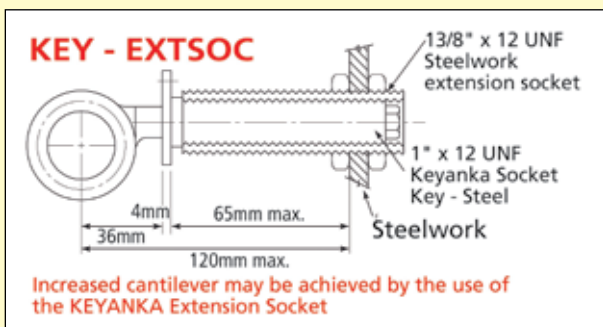
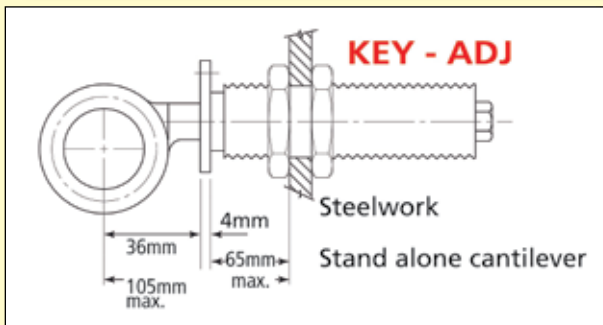
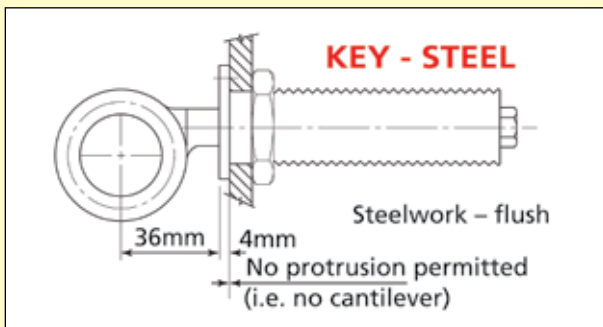

Increased cantilever may be achieved by the use of the KEYANKA Extension Socket

#### NOTES:

- 1 **KEY-STEEL** must **never** be used with any thread protruding.
- 2 When using **KEY-EXTSOC** extension sockets, the **KEYANKA** (KEY-STEEL) must be fully screwed in to the collar.
- 3 **KEYANKA** and extension sockets should be ordered separately.

### KEYANKA in Masonry

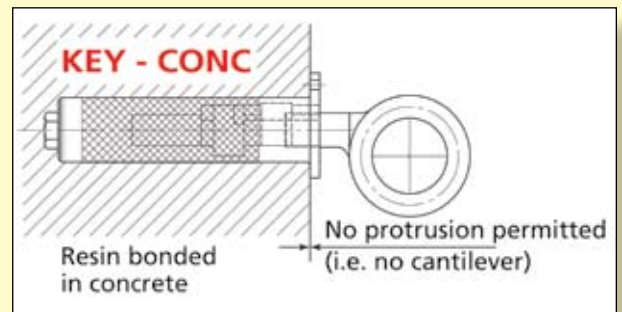

**KEY-CONC** Standard **KEYANKA** socket suitable for resin bonding into minimum 150mm thick concrete ONLY. NO cantilever permitted.

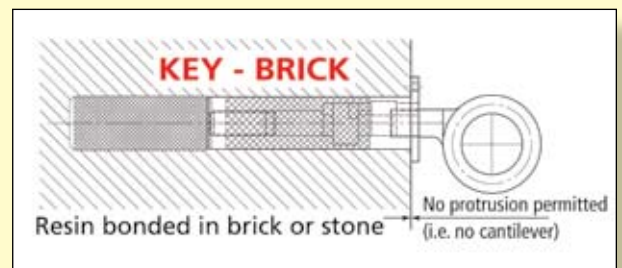

**KEY-BRICK** Standard **KEYANKA** socket with knurled extension suitable for resin bonding into min. 225mm thick solid masonry. NO cantilever permitted.

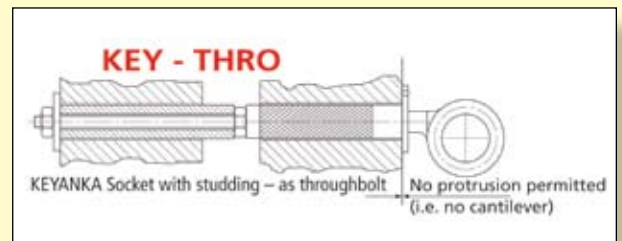

**KEY-THRO** Standard **KEYANKA** socket with additional M12 threaded extender. For use as through bolt fixing (e.g. in cavity walls). NO cantilever permitted.



## Cantilever Sockets for KEYANKA

### For Brickwork

Code	Max. Cantilever (mm)	Min.	Min. Socket Length (mm)
KA-CANT200	50	150	200
KA-CANT225	75	150	225
KA-CANT250	100	150	250

### For Concrete

Code	Max. Cantilever (mm)	Min. Embedment (mm)	Min. Socket Length (mm)
KA-CANT175	65	110	175
KA-CANT200	75	120	195
KA-CANT225	100	125	225
KA-CANT270	125	140	265
KA-CANT335	150	160	310
KA-CANT380	175	180	355

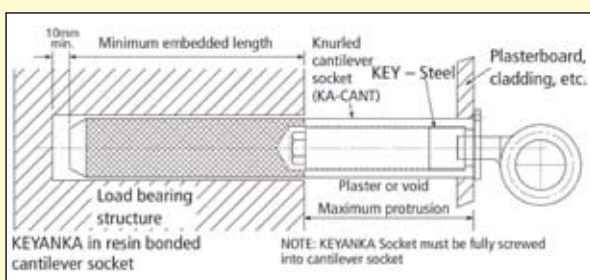

**KEY-CANT** Knurled cantilever socket for use in conjunction with standard **KEY-STEEL KEYANKA** socket in concrete and masonry.

## Other Applications

**KEYANKA** bracket to bridge void under floors, above ceilings or behind cladding. For direct axial loading only – unless the cladding etc. provides adequate resistance to bending. Use in conjunction with **KEY-STEEL**, or, if **A** is greater than 25mm, **KEY-ADJ. KEYANKA** bridge, sockets and locknuts should be ordered as separate items.

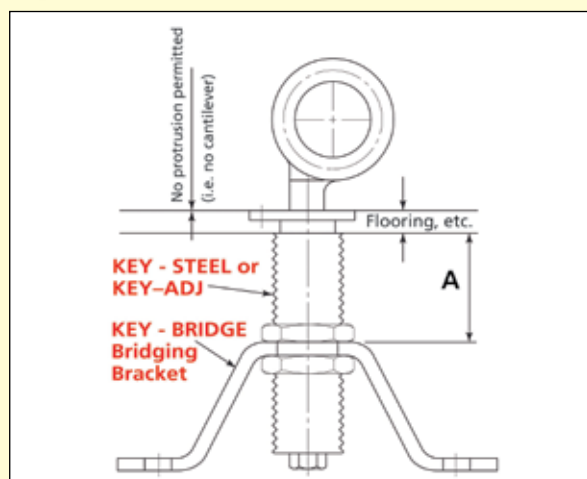
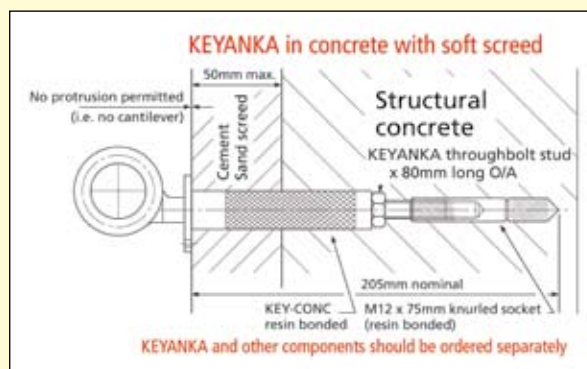

## Ringanka

A KEE SAFETY PRODUCT

## Class A1 Anchor Devices

**RINGANKA** is a comprehensive range of Class A1 safety eyebolts conforming to EN 795, BS 7883 and ISO 14567.

**RINGANKA** eyebolts for use in brick, concrete and masonry have a 16mm diameter unthreaded shank to 'plug' a drilled hole, thus reducing the bending effects which would result in earlier failure during shear loading. These safety eyebolts can be used by fixing to an outside or inside face of a structural element adjacent to a window or other access. They are manufactured from either high tensile carbon steel with a galvanised or plastic-coated finish, or grade 316 stainless steel.



## Periodic Inspection

BS7883 requires that, wherever possible, all safety anchor devices are removable for periodic inspection. This is easily achieved by using our Knurled Inserts in conjunction with our Resin Capsules. We also offer PPE Warning Discs, which are required for compliance with EN 795.

**A** M12 Female Threaded Knurled Inserts are available in lengths of 76mm, 102mm, 120mm, and 150mm to suit varying installation situations. N.B. 76mm sockets should ONLY be used in DENSE concrete.

**B** 16mm diameter resin capsules should be used with M12 Female Threaded Knurled inserts.

**C** Threaded Connectors to extend eyebolts, for use as Through-Bolts (BS7883).

The associated All-Thread is also available.

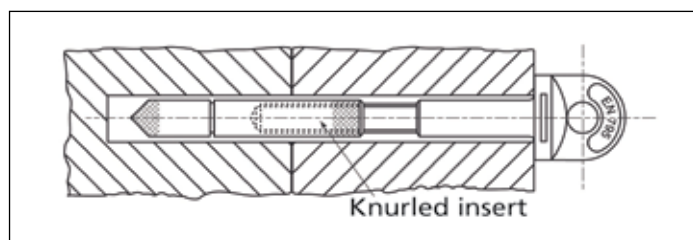
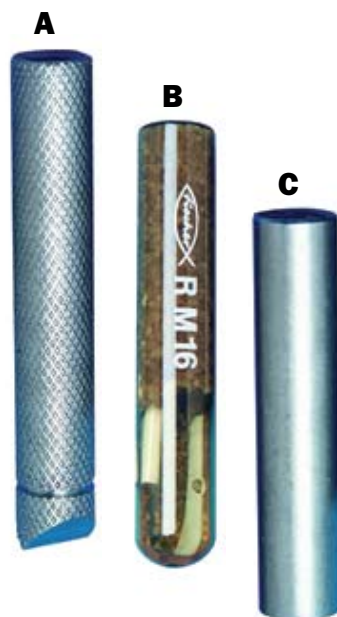

100mm or 152mm shank length. Used in brick, concrete, etc. with chemically anchored socket and knurled insert. (BS 7883 Fig. 7)

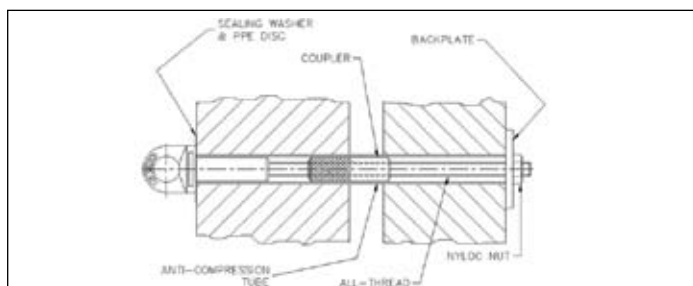

Eyebolt extended with threaded connector and all-thread for use as a through-bolt in solid or cavity wall. (BS 7883 Fig. 9)

### Warning Disc

This is required to comply with EN 795. Each disc must state whether usage is for Fall Arrest, Fall Restraint, Rope Access or Work Positioning. They are available, printed with your company name (at extra cost). Polythene Sealing Washers are also available.

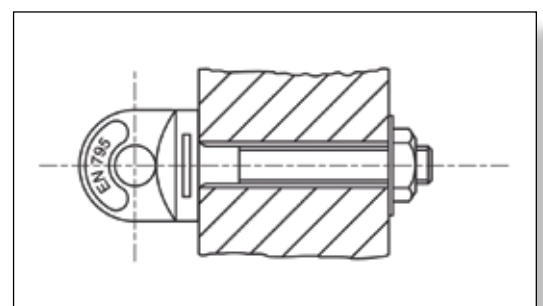

75mm shank length used ONLY on steel structures (BS 7883 Fig 9)

## Cantilever Anchor Devices

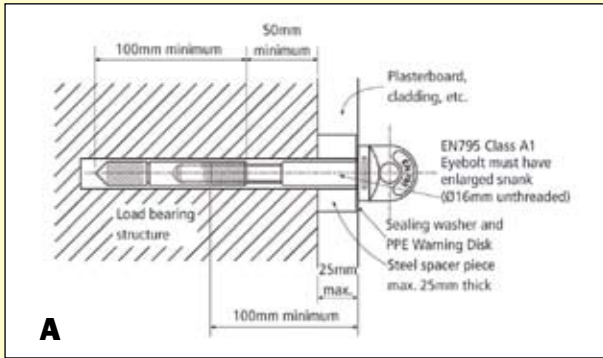

We also offer **Cantilever Anchor Devices** for use in dry lined walls or in conjunction with plasterboard, cladding etc. Where the distance from the face of the load bearing structure to the collar of the eyebolt does not exceed 25mm, a **spacer sleeve** may be placed under the eyebolt collar to provide the necessary support (Fig. A).

Where the distance from the face of the load bearing structure to the collar of the eyebolt exceeds 25mm, special **cantilever sockets** are available. Where the distance to be bridged exceeds 175mm (100mm in brick) special advice should be sought (Fig. B).

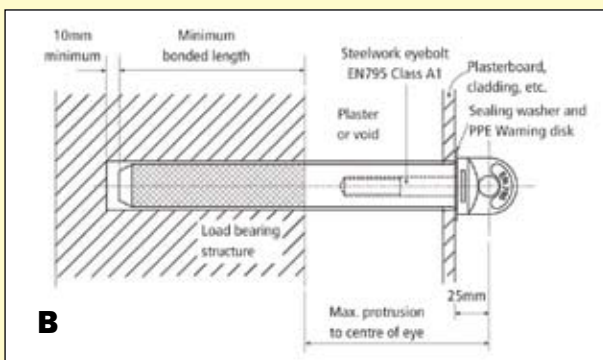

## Cantilever Sockets for RINGANKA

### For Brickwork

Code	Max. Cantilever (mm)	Min. Embedment (mm)	Min. Socket Length (mm)
<b>CANTI200</b>	50	150	200
<b>CANTI225</b>	75	150	225
<b>CANTI250</b>	100	150	250

### For Concrete

Code	Max. Cantilever (mm)	Min. Embedment (mm)	Min. Socket Length (mm)
<b>CANTI175</b>	65	110	175
<b>CANTI200</b>	75	120	195
<b>CANTI225</b>	100	125	225
<b>CANTI270</b>	125	140	265
<b>CANTI335</b>	150	160	310
<b>CANTI380</b>	175	180	355

### General Requirements for Cantilever Anchor Devices

- 1 Maximum permitted in-service force = 6kN (design capability = 10kN as per EN 795); i.e. all users must be protected by the provision of an energy absorber to EN 355
- 2 Load bearing structures and chemical fixings must be capable of withstanding a 10kN pull-out force
- 3 Each individual installed anchor device must be subjected to a 6kN pull-out force (as per BS 7883)
- 4 It should be noted that, when installed into materials of less than 20Nmm<sup>2</sup> compressive strengths, there may be local crushing/compacting around the drilled hole at fall arrest.

**Kee®  
Safety**

Kee Safety Ltd  
1 Boulton Road  
Reading  
Berkshire  
RG2 0NH  
Tel: 0118 931 1022  
Fax: 0118 931 1146  
Email: sales@keesafety.com  
Web: www.keesafety.com

Kee Safety Ltd  
Cradley Business Park  
Overend Road, Cradley Heath  
West Midlands  
B64 7DW  
Tel: 01384 563380  
Fax: 01384 563381  
Email: enquiries@keesafety.com  
Web: www.keesafety.com