



YOU'LL NEVER BE BETTER PROTECTED

Fall Arrest Anchor Solutions



- EACH TYPE TESTED AT THE NATIONAL ENGINEERING LABORATORY
- ROOFANKA AND RIDGANKA CE APPROVED TO THE PPE DIRECTIVE
- COMPREHENSIVE FALL ARREST PROTECTION ON MOST TYPES OF ROOFS

KEE ROOFPOINT fall arrest anchor solutions provides a range of permanently fixed roof anchor points designed to promote safer working on roofs. **ROOFANKA**, **RIDGANKA** and **POSTANKA** all offer solutions to solve different access problems when used correctly in conjunction with the appropriate PPE (Personal Protection Equipment). Each of the products has been independently tested by the National Engineering Laboratory, with Roofanka and Ridganka CE approved to meet the PPE Directive

As a leading supplier of fall protection solutions, **Kee Safety** offers a range of collective and personal protection products including **KEEGUARD**, **KEE DOME**, **KEE ANCHOR** and **KEE I-BOLT**. Our technical team can offer practical assistance in all aspects of design, installation and compliance with relevant standards for each of these products.



Roofanka

A KEE SAFETY PRODUCT

Why you need ROOFANKA

ROOFANKA is a comprehensive range of fall arrest anchors for use on most types and sizes of roof support, either as a single point anchor device or as a structural anchor.

When used for Fall Arrest, **ROOFANKA** serves as a fall arrest anchor, ladder hook and crawling board clamp for the attachment of industrial safety belts and harnesses and to secure roof ladders, crawling boards, work platforms etc. **ROOFANKA** has been designed and tested to Class A2 & C EN 795, Class A EN 517, BS 7883 and ISO 14567.

Structural Anchors are used with horizontal flexible safety lines to EN 795 Class C. They have been designed and tested to EN 795: CLASS A2 & C, EN 517: CLASS A, BS 7883 and ISO 14567.



‘Kee’ Features of ROOFANKA

- Independently tested at N.E.L. (National Engineering Laboratory, East Kilbride, N.B. 0320)
- Conforms to Class A2 & C EN 795, BS 7883 & ISO 14567
- CE Approved to PPE Directive
- Provides single point attachment for fall protection use
- Provides ladder hook to position roof ladder
- Provides clamp to support crawling boards
- Incorporates patented weatherproof seal
- All components above the roof are stainless and internal components are galvanised
- Slope mounted, therefore can be placed next to roof access point
- Galvanised to BS EN ISO 1461

Fall Arrest Anchors

Direction of Loading

Due to the potential weaknesses in timber roof structures, the basic models (product codes RANKAUK and RANKAEX) should only be used where the direction of loading would always be in the plane

(i.e. down the slope) of the roof. Where it is possible that the arrest of a fall may result in forces applied across the roof structure (e.g. by a fall over a gable end), special versions of **ROOFANKA** should be employed. The addition of a lateral brace shares the bending moment with the adjacent rafter to resist potentially high torsional bending of the roof timbers. See product codes RANKAUK-GE and RANKAEX-GE.

Specification: EN 795 Class A2 and EN 517 Type A, one user only, with a maximum loading of 10kN.

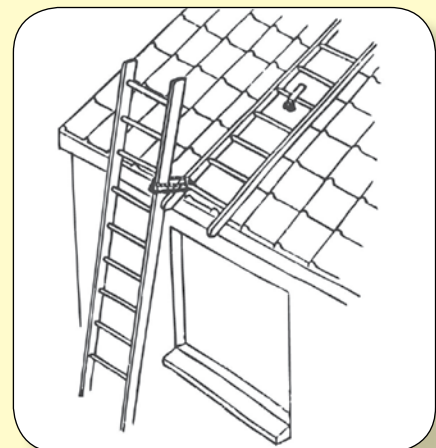

Product Code	Min. Roof member (mm)	Max. Roof member (mm)	Transverse forces OK?
RANKAUK	72 x 35	152 x 65	NO
RANKAUK-GE	72 x 35	152 x 65	YES
RANKAEX	135 x 65	220 x 120	NO
RANKAEX-GE	135 x 65	220 x 120	YES

Structural Anchors and Installation Selection

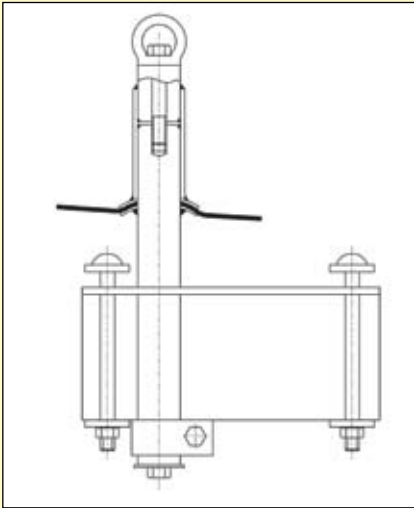

Detail of an anchor pedestal and the bracketry for attachment to a roof truss.

A set of combination fall arrest anchor, ladder hook and crawler board clamps in use and a series of anchor pedestals supporting a horizontal lifeline.

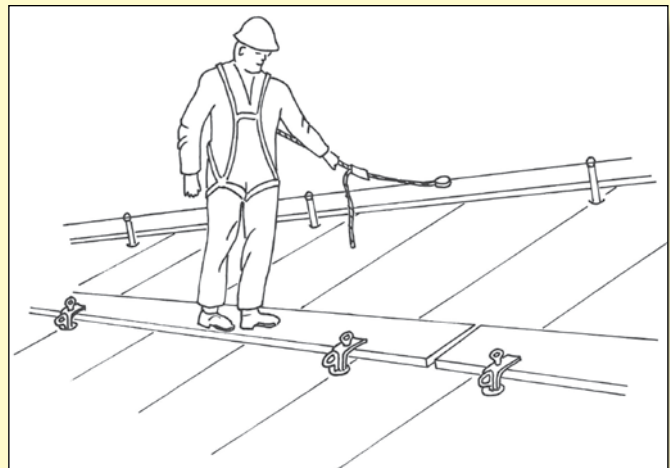

Both intermediate and extremity anchors are available but it is important that intermediate anchors should ONLY be used where the direction of loading is down the slope of the roof. For extremity anchors the direction of loading can be in the plane of the roof, at right angles to the axis of the truss/joint, or at any intermediate angle. In all cases the horizontal line should be no more than 300mm above the surface of the roof.

Product Code	Min. Roof member (mm)	Max. Roof member (mm)	Max. users	Max. loading	Transverse forces OK?
RANKAUK-IA	72 x 35	152 x 65	No limit	10kN	NO
RANKAUK-EA	72 x 35	152 x 65	One	10kN	YES
RANKAEX-IA	135 x 65	220 x 120	No limit	10kN	NO
RANKAEX-EA	135 x 65	220 x 120	One	10kN	YES
RANKA-EA30	135 x 65	220 x 120	No limit	30kN	YES

- NOTES:**
- Where the product code suffix is IA the product must only be used as intermediate anchors, no transverse forces are allowed.
 - Only RANKA-EA30 may be used as an extremity anchor on multi-user systems.
 - For RANKAUK-EA where the roof member is timber, the minimum depth should be increased to 97mm (by nailing and gluing) for at least 500mm each side of the **ROOFANKA**.

Selecting the Position for Installation

Each **ROOFANKA** must be installed in a position such that the user is afforded maximum security at all times. The choice of position must take regard of the following:

Free Movement over the Roof

It is recommended that the anchor line, in conjunction with a manually adjusted rope grab should be used by anyone working on the roof. The safety line should be attached to a **ROOFANKA** as near as possible to the apex of the roof, and the rope grab attached to a connector which in turn should be fastened to the user's safety harness at the dorsal attachment point. The length of the safety line and the position of a **ROOFANKA** should be such that, while

attached to the first **ROOFANKA**, the user may move to a second **ROOFANKA**, near the apex of the roof, to which he can attach the loose end of his safety line. At this time he should reverse the rope grab, return to the first **ROOFANKA** and detach the safety line in order to continue working. Note that it is advisable for total security for the user to have a spare short adjuster attached to his harness so that this may be attached to a **ROOFANKA** eye while the rope grab is being reversed.

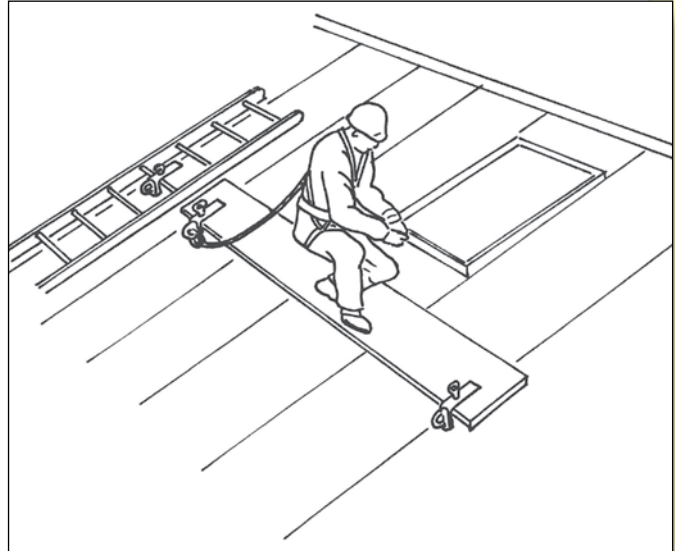

Means of Access to the Roof

ROOFANKA should be positioned such that the user may attach his safety line before he climbs on to the roof, usually at the point where he would transfer from ladder to roof.

Securing Crawling Boards, Edge Protection or Working Platforms

The **ROOFANKA** Crawler Board Clamp is designed for use with 50mm thick scaffold planks but may also be used with 32mm and 38mm thick planks.

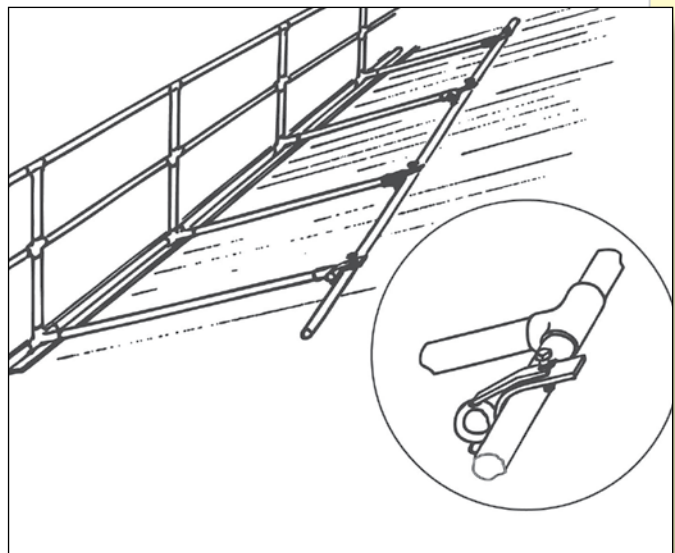

Clause 13 of the Construction (Working Places) Regulations 1966 – S.I. 1966 No. 94 gives advice on the distance between supports for scaffold planks which should be followed when installing **ROOFANKA** to secure crawling boards, edge protection or working platforms, etc.

Where a **ROOFANKA** installation is intended to have a dual role (i.e. single point anchorage and support for crawler boards etc.), all the recommendations given should be complied with.

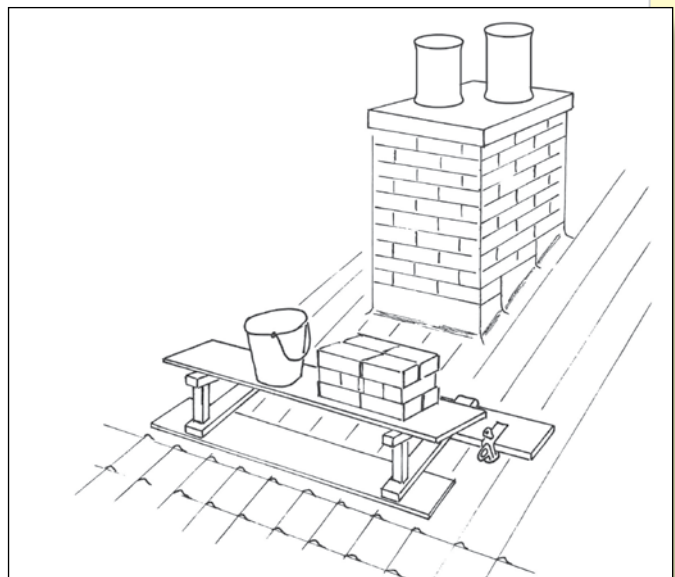

RIDGANKA is a permanently fixed, secure fall arrest anchor specifically designed to be mounted at the ridge of a pitched roof. The safest position for fall arrest anchors is above the position of the user which means, where possible, on a pitched roof, the anchorage should be at the ridge.

RIDGANKA is manufactured from high quality carbon steel, and all components within the roof space are galvanised to EN ISO 1461. The eyebolt which projects above the ridge is a Class A1 steelwork fixing anchor device produced in grade 316 stainless steel.

Safety First

RIDGANKA is designed in accordance with EN 795: CLASS A1 and meets the testing requirements of that standard. It also withstands the BS 7883 test force of 10kN along the slope of the roof without distortion. Importantly, **RIDGANKA** is designed for single user applications only.

Installation is by means of a special clamping arrangement directly on to either the ridge batten or the apex of the sloping truss assembly. Waterproofing around the eyebolt is by means of both lead flashing and silicon sealant.



The following table shows the sizes available, the maximum and minimum timber sizes to which they may be attached and the type of roof construction with which they may be used.

Product Code	Ridge Beam Depth (in mm)		Truss Depth (in mm)		Strut Depth (in mm)	
	Min.	Max.	Min.	Max.	Min.	Max.
RIDGE-RB-S	125	180	-	-	-	-
RIDGE-RB-L	175	230	-	-	-	-
RIDGE-ST-S	-	-	97	120	72	97

'Kee' Features and Benefits of RIDGANKA

- Independently tested at N.E.L. (National Engineering Laboratory, East Kilbride N.B. 0320)
- Conforms to Class A 1 EN 795, BS 7883 & ISO 14567
- CE Approved to PPE Directive
- Provides single point attachment for fall protection use
- Installation at ridge provides access to both pitches of the roof
- Installation at ridge ensures anchor point is always above the user
- All components below the roof are galvanised to BS EN ISO 1461
- Adjustable to fit a wide range of roof trusses
- Two sizes available to accommodate roof trusses from 72mm x 97mm up to 175mm x 230mm
- Low cost solution to fall protection on tiled roofs
- Removes the need to erect scaffolding for short term maintenance work
- Always available for immediate use once installed

Installation

The position of **RIDGANKA** should always be approved by an architect or structural engineer. Ensure that the roof member to which it is attached is capable of withstanding the forces generated if a fall is arrested. Where necessary, the timber may be strengthened by nailing and gluing additional timber to the beam/truss for at least 500mm each side of the **RIDGANKA**.

After drilling (trepanning) a suitable hole in the ridge tile, the pedestal is inserted through this hole and **RIDGANKA** is fixed by clamping to the ridge batten or the apex of the roof truss as appropriate. The design of the **RIDGANKA** clamp and pedestal permit adjustment to ensure that the eyebolt is installed at the optimum height. It is, however, important that the maximum height of the eyebolt above the top 'U' bolt should not be exceeded. Special versions of **RIDGANKA** can be supplied where additional height is required. Any gap between the hole cut into the ridge tile and the pedestal is sealed using silicon sealant and lead flashing is positioned over the pedestal, under the collar of the eyebolt, to produce a double waterproof seal.



Typical Installation Options

Detail of RIDGANKA type RIDGE-RB attached to a ridge batten.

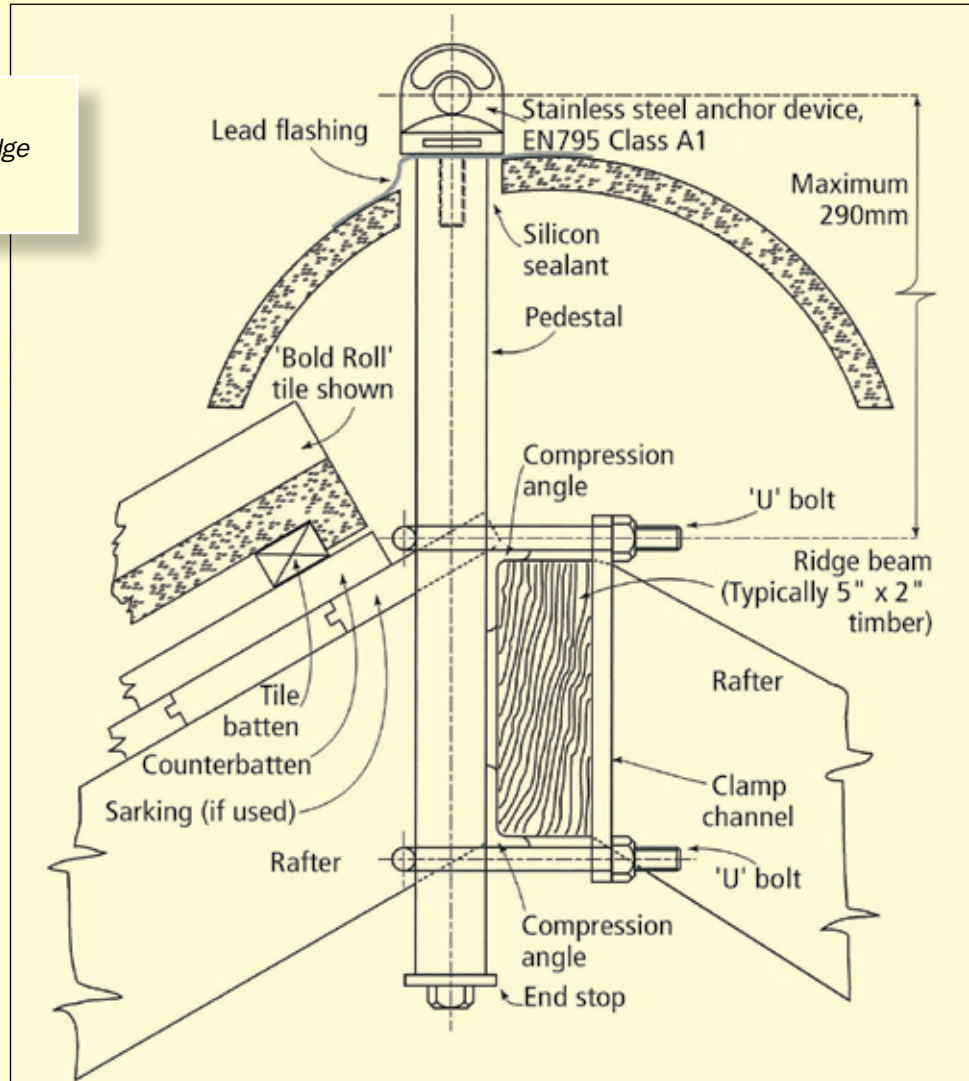

Detail of RIDGANKA type RIDGE-ST attached to sloping truss assembly.

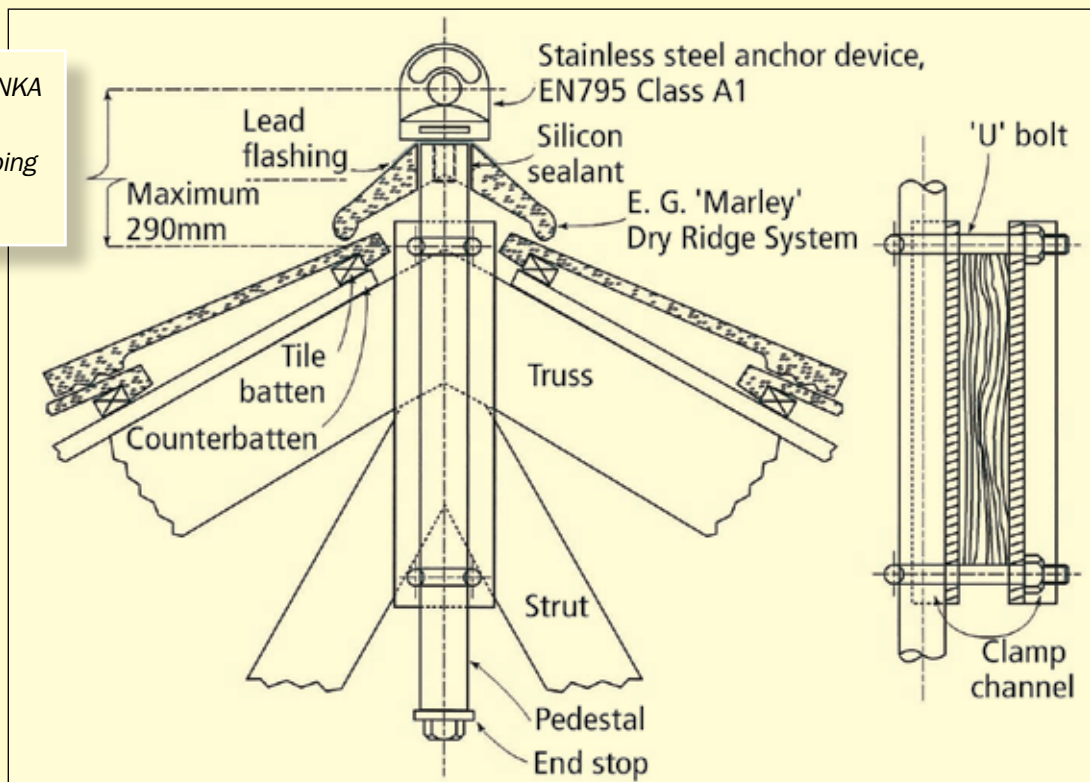

POSTANKA is a comprehensive range of Anchor Pedestals for use with horizontal flexible safety lines to EN 795 and BS 7883 Class 'C', or as supports for single point anchor devices.

EN 795 requires that structural posts should be designed to withstand twice the force to which they will be subjected at fall arrest or restraint. Relevant calculations must be performed by a qualified engineer.

All **POSTANKA** structural pedestals are designed using formulae verified by a qualified engineer. Kee Safety Ltd can provide design calculations for all **POSTANKA** pedestals if required.



Samples of each type of pedestal have been tested by the National Engineering Laboratory to verify that the design formulae produce safe products which meet the relevant criteria of EN 795.

'Kee' Features and Benefits of POSTANKA

- **Sample tested at N.E.L. (National Engineering Laboratory, East Kilbride N.B. 0320) to verify design formulae for products to meet EN 795**
- **Conforms to EN 795 Class A2 and Class C**
- **Galvanised to BS EN ISO 1461**
- **Provides supports for use with horizontal flexible safety lines**
- **Provides single point attachment for fall protection use and rope access work**
- **Designed to withstand twice the force that would be subjected at fall arrest**
- **May be bolted directly to concrete roof using resin bonded sockets**
- **May be attached directly to steel structures using Beamclamp® Steelwork Fixings**
- **May be clamped to side of Beam, Joists, Channels, etc.**
- **Inexpensive installation costs**
- **High grade steel provides low weight units**



TYPE 3

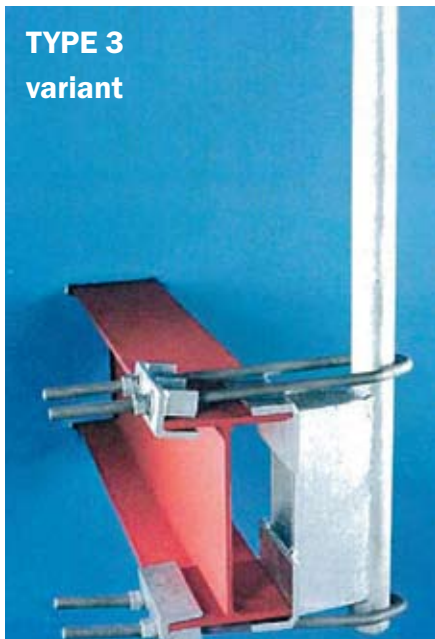
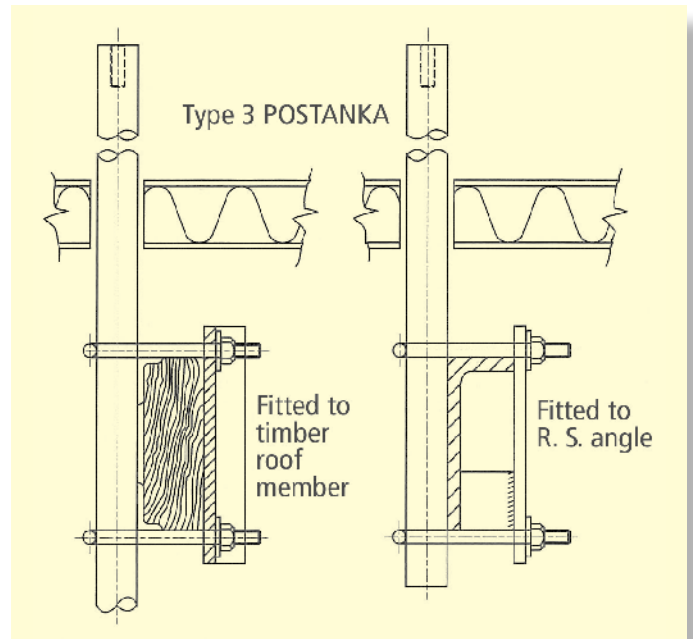

**TYPE 3
variant**

TYPE 3 A 'height adjustable' pedestal designed to be attached to the side of the Universal Beam, Joist, Channel, etc. The anchor design provides the added advantage of inexpensive installation costs. The use of a special, high grade steel for the pedestal provides a low weight unit.

Variations of the **TYPE 3 POSTANKA** are available to allow for attachment to RSJ's, Universal Beams, Channels and Angles. This includes a purpose-made variation of Type 3 (Type 4), to enable the pedestal to pass through roof cladding at a desired point not immediately above the roof joist or other member. It is particularly useful to ensure that the roof penetrates the cladding at the top of a 'crest' on profile sheeting.

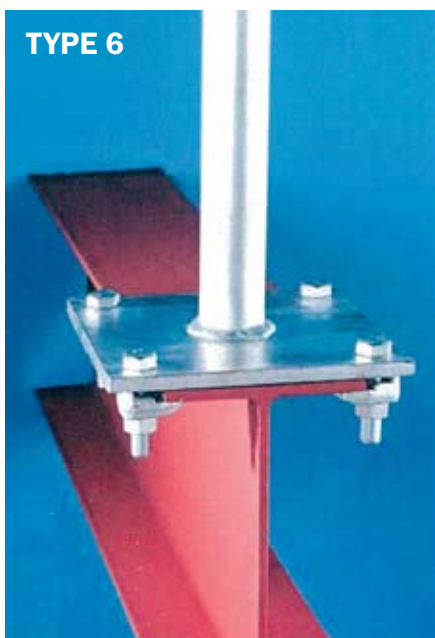

TYPE 6

TYPE 6 A traditional 'post and base plate' assembly, but WITHOUT support gussets. As the absence of gussets produces greater bending moments at the post/base plate junction, additional weld is necessary to provide adequate strength. This type of pedestal is recommended where the clearance between the roof member and cladding is insufficient to accommodate gussets. May be bolted directly to concrete roofs using chemically bonded internally threaded inserts, or attached to steel elements of the main structure. This may be achieved using Beamclamp® steelwork fixings (or similar), or by using a second base plate and tie rods to 'sandwich' the roof member.

TYPE 8



TYPE 8 'Weldless' pedestals are the latest in the comprehensive **KEE ROOFPOINT** range of anchor pedestals for use with Class C horizontal wire safety systems to EN 795 and BS 7883. The mechanical assembly method of production enables a range of standard components to be used to assemble individual pedestals to meet each customers' requirement. In situations where restricted clearances make it difficult to install the pedestal from below the roof cladding, 'weldless' pedestals may be dismantled so that only the base is bolted to the roof structure. The pedestal may then be inserted from above, through a relatively small hole cut into the cladding.

Personal Protective Equipment



All fall arrest and fall restraint systems are required to be used in conjunction with Personal Protective Equipment, which usually comprises of full body harness and lanyard as a minimum.

Fall Arrest Harnesses are manufactured from quality polyester webbing which exceeds the minimum strength requirements in the European Standards. They are designed with comfort and ease of donning in mind.

Fall arrest harnesses should be used in conjunction with an appropriate and suitable fall arrest lanyard or other compatible fall arrest devices.



Photo Gallery



Kee Safety Ltd
1 Boulton Road
Reading
Berkshire
RG2 0NH

Tel: 0118 931 1022
Fax: 0118 931 1146

Email: sales@keesafety.com
Web: www.keesafety.com

Kee Safety Ltd
Cradley Business Park
Overend Road, Cradley Heath
West Midlands
B64 7DW

Tel: 01384 632390
Fax: 01384 632391

Email: enquiries@keesafety.com
Web: www.keesafety.com