

THE **DYNAMICS** OF **MOVEMENT**

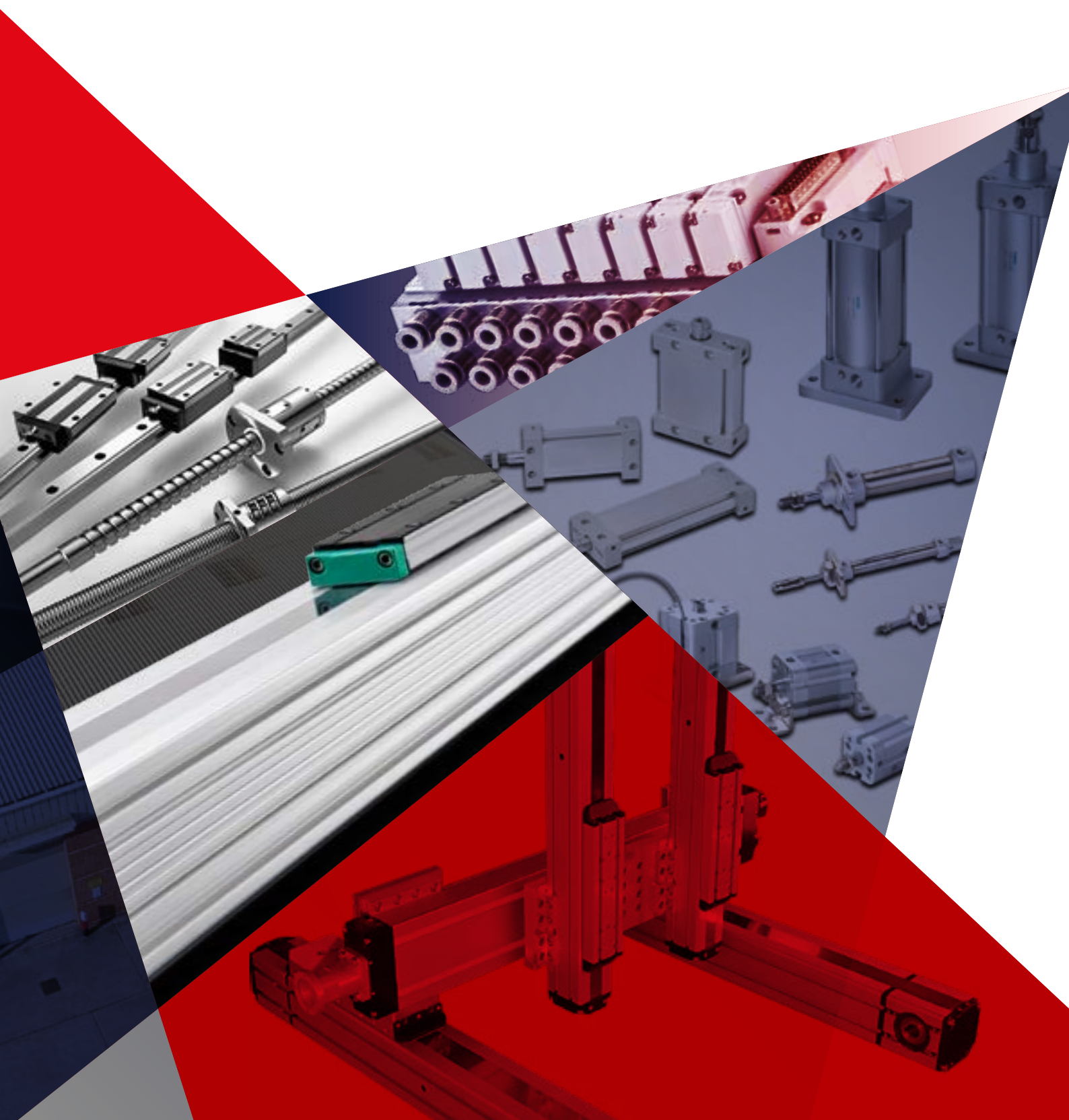

Product Overview



WELCOME TO MATARA

Specialists in Automation, Pneumatics and Linear Motion for over 20 years.

We work hard to deliver an unbeatable range of pneumatic and linear automation products, backed up with technical expertise, market leading value and a clear commitment to customer service.

From our headquarters in Gloucestershire, our team manufacture and supply to a wide portfolio of customers across all sectors of industry. From automotive to aerospace, food to pharmaceuticals, our reputation has grown as the partner of choice for service, delivery and peace of mind.

As a privately owned business, we are able to operate on a more flexible basis than others in our sector and we know that our clients appreciate this as they see the direct benefit in areas such as;

- Consistent pricing policies
- Direct relationships with key personnel and management
- Short and effective lines of communication

XYZ GANTRY SYSTEMS



Our specialist areas of manufacture and supply enable us to stay focussed on our core range, building upon our expertise and working with our partners throughout the world to deliver the best products at the best price.

Made For You Today – Your Order, Your Way

01684 850000
sales@matarauk.co.uk

Gloucestershire has been the home of Rodless Cylinders for more than 35 years and Matarauk manufacture a full range of Standard Guided, Unguided, Braked and now customised Rodless Cylinders at their HQ, nestled in the heart of the Cotswolds.

Stroke Lengths of up to 6 Metres are available on bore sizes from 16Ø > 63Ø. All sizes can be manufactured and shipped on a same day basis.

Precision Guided models are available as are Duplex and High Temperature units.



Matarauk have built up an enviable reputation for being able to supply custom made pneumatic cylinders on a same day turn around.

This service has now been extended throughout the PMI Linear Rail Range.

Same day Butt Joins Are Available On All Sizes from 7mm > 65mm Width.

On many occasions Matarauk are also able to supply fully machined Ballscrews within 24 hours having recently purchased another HAAS CNC.



Mindman manufacture a full range of pneumatic equipment and are considered the market leader in South Eastern Asia.

From its inception more than 35 years ago, Mindman currently manufacture in five large factories and in 2011 opened an automated distribution centre enabling same week manufacture and despatch anywhere in the world.

Many Mindman items have the same or similar dimensions to SMC, Koganei and CKD enabling customers to enjoy freedom of choice when selecting products.

Matarauk manufacture many Mindman Cylinders for same day despatch.

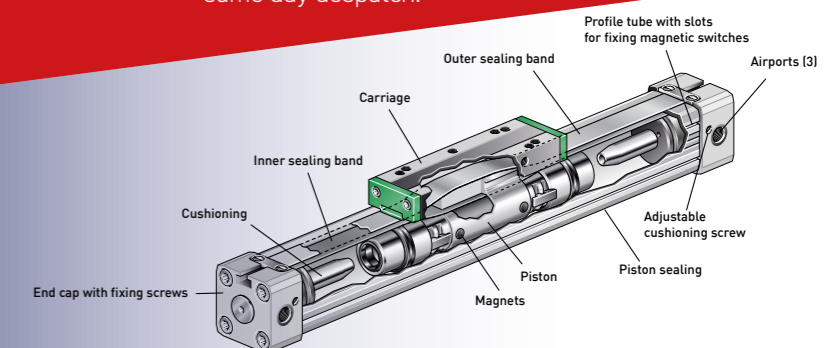

LINEAR GUIDE WAYS-PMI

Precision Motion Industries have been manufacturing Ballscrews and Linear Guides for more than 30 years and dominate the Asian Machine Tool Industry.

Material is sourced from Germany and is then subjected to extremely rigorous heat treatment and Grinding Processes. The end result is an extremely high quality Linear Rail and Bearing Assembly.

Ballscrews are also manufactured by PMI and can be machined to any detail in our own CNC Machine Shop.

Same day Butt Joints are available on all sizes from 7mm > 65mm width. Armoloy Coating is an optional extra.

Tapped Hole in the end face of the rail is an optional extra.

Dowel Holes / Dowels anywhere along the length of the rail can be provided if required.



MSA TYPE

HEAVY LOAD TYPE LINEAR GUIDE WAY

- Equal loads in all directions
- All levels of pre-load
- Self aligning
- Interchangeable type 15mm > 65mm
- N, H, P, SP Grades of precision



MSB TYPE

HIGH LOAD TYPE LINEAR GUIDE WAY

- Equal loads in all directions
- Compact-low height
- Self aligning
- Interchangeable type 15mm > 35mm
- N, H, P, SP Grades of precision



MSG TYPE

WIDE TYPE LINEAR GUIDE WAY

- Equal loads in all directions
- All levels of pre-load
- Self aligning
- Interchangeable types: 21, 27, 35, 15mm > 65mm
- N, H, P, SP Grades of precision



SME TYPE

CAGED RETAINED LINEAR GUIDE WAY

- High loads in all directions
- Smooth movement with low noise
- Self aligning
- Interchangeable type 15mm > 45mm
- N, H, P, SP Grade



MSC MSD TYPE

MINIATURE LINEAR GUIDE WAY

- Four-way equal load
- Smooth movement with low noise
- Ultra compact - stainless steel
- Interchangeable type 7mm > 15mm
- Stainless steel
- Wide & standard width
- Up to 2m length
- N, H, P Grade

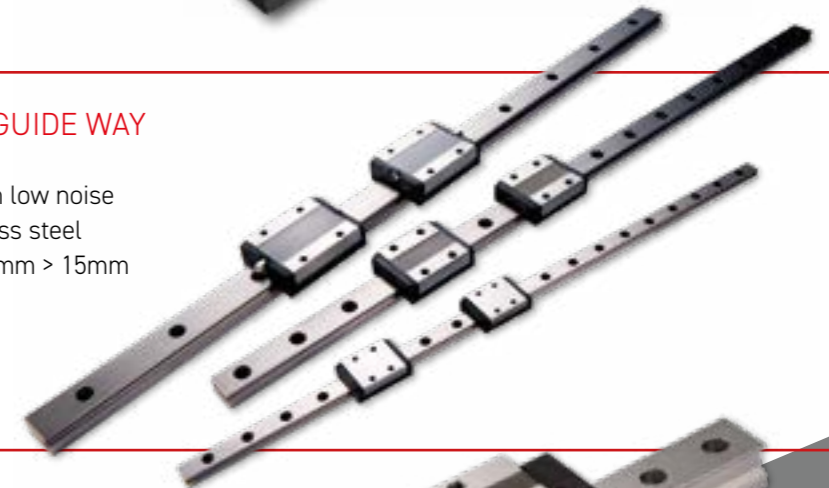

SMR MSR TYPE

ROLLER GUIDE

- Ultra heavy loads
- Ultra high rigidity
- Low noise when running
- N, H, P, SP Grade
- Any pre-load

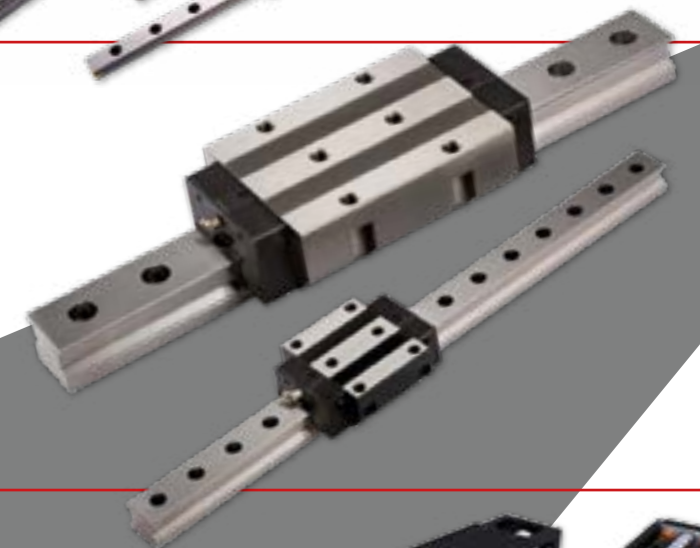

KM ACTUATOR

BALLSCREW DRIVEN

- Four Directional equal load, high rigidity
- Saves space - very compact
- High accuracy (N, H, P, SP)
- Size six available
- Bellows - cover available
- High rigidity
- Ground or rolled ballscrew inside



LINEAR RAIL, CUT IN-HOUSE
TO YOUR SPECIFICATION



PRECISION GROUND & ROLLED BALLSCREWS







Rolled Ballscrews- machined in-house - Preferred stock as listed below



SFNI SERIES  NEW	SFNU SERIES  NEW	SFV SERIES 	OFI/DFI SERIES 
OFU/DFU SERIES 	SFM SERIES 	DFM SERIES 	SCNH SERIES 
OFV/DFV SERIES 	SFY SERIES 	DFS SERIES 	SFNH SERIES 
SFK SERIES 	BSH SERIES 	SSVW SERIES 	SCNI SERIES  NEW

BALL SPLINES

Flanged & Non Flanged - Unique 40° Angular Contact

SLF SERIES 	SLT SERIES 	SOF SERIES 	SOT SERIES 
RFSY SERIES  NEW	RFBY SERIES  NEW	RLSF SERIES  NEW	RLBF SERIES  NEW

PRECISION ROTARY BALLSCREW - SPLINE

POWER LEADSCREWS



IN-HOUSE BALLSCREW & LEADSCREW MACHINING

Matara have an extensive range of modern CNC machinery & as such are able to over precise, accurate and repeatable machining of a wide range of linear components, from ballscrew, to shafting to leadscrew. Our current plant includes HAAS-ST10-Y, DS30SSY TM2P, XYZ SLX1630 (2 Off), SLX 425, XYZ SLV.

Our range of Trapezoidal Screws are precision rolled to offer extremely high levels of accuracy and continuity.

The Carbon Steel units are manufactured from EN10084 C15E-1-1141 which has a surface hardness after rolling of 160- 180HB. We are also able to offer alternative standard steels and stainless steel INOX-AISI-304 & 316.

Nuts are available in a variety of materials from steel through to bronze, brass and plastic.

BALLSCREW & LEADSCREW END SUPPORTS

Matara hold stock of an extensive range of ballscrew and leadscrew end supports to suit many types of application. With both fixed and floated side types available, Matara can offer you the complete package when it comes to your ballscrew or leadscrew specification.



Ballnut Mounts & Motor Mounts also available



Machined to your Specification:

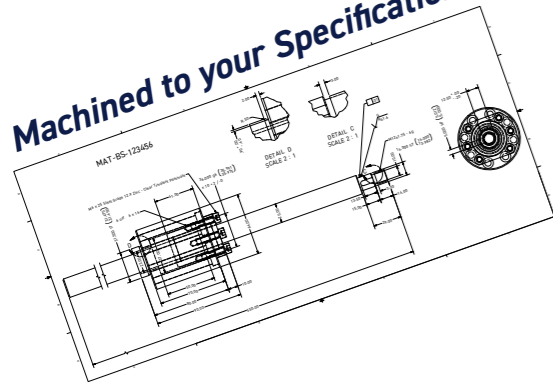

PM (PRECISE METAAL)



Matara have been a partner of PM for more than two years. During this time, many UK customers have experienced, first-hand, both individual PM Linear Products as well as complete ultra-high precision XY Tables.



CROSS ROLLERS



RADIAL BEARINGS



XY STAGES

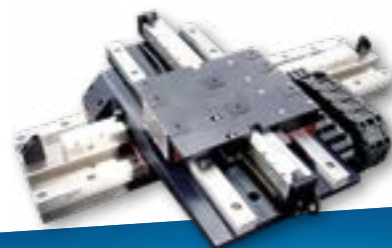

PRECISION RACK & PINION

With or without customised heat treatment...

- Helical & Straight rack
- MOD 0.5 > 42
- Hardened or non-hardened & drilled or undrilled to customer's drawing.
- Pinions available for all sizes, machined or unmachined.

STRAIGHT RACKS

HELICAL RACKS

HELICAL PINIONS

STRAIGHT PINIONS

MODULAR ALUMINIUM EXTRUSION

LARGE UK STOCKHOLDING

- Complete Frames
- Flat-Pack, Pre-Drilled
- Complete Lengths
- Competitive Delivery Rates
- Interchangeable With Other Makes
- Simple Ordering Via Webstore
- Extensive Technical Support

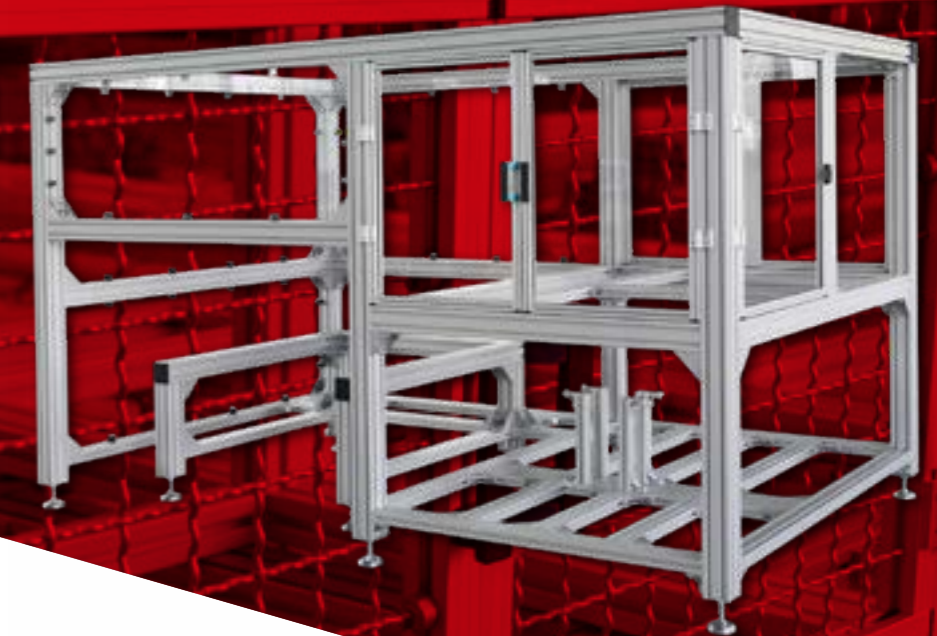

PG20



PG30



PG40



PG60



PG45



PG50



Accessories



CUT IN-HOUSE

Matara are the company with the right profile to exceed your demands on aluminium framework and accessories.

Whether it's one piece of aluminium or a complete frame, Matara's engineers can quickly establish your demands and supply you with competitively priced quality product.

With four precision aluminium saws, a fully equipped CNC machine shop and a team of qualified engineers, Matara can provide a single stop solution for pre-cut machined lengths, complete frameworks or frameworks with Linear Rails and Actuators mounted.

LINEAR ACTUATOR SYSTEMS

Linear actuators are the core component of many production machine and automation systems and as such reliability, accuracy and repeatability are often the pre-requisites of any unit. Matara design and build many of its Belt and Ballscrew units in house. Belt drives use proven AT Steel Core Belting with precision pinions as well as PMI Linear Rails & Carriages.



Belt Driven Type

MTB SERIES

INTERNALLY GUIDED

- High loads
- High speeds
- Internally guided
- Any length of stroke available, up to 18 metres
- PMI Rail inside unit
- Sealed unit
- Built in the UK

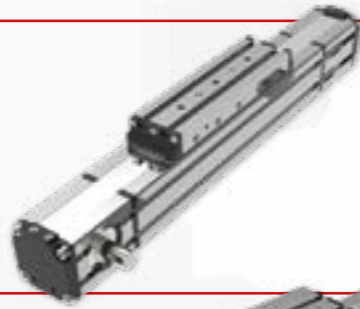

MTE SERIES

SINGLE EXTERNAL & INTERNAL GUIDE

- High loads
- High speeds
- Internally guided
- Any length of stroke available, up to 18 metres
- PMI Rail on the inside and the outside of the unit
- Sealed unit
- Built in the UK



MTS SERIES

DOUBLE EXTERNAL & SINGLE INTERNAL GUIDE

- Internally & externally guided
- PMI Linear Rail fitted internally & externally
- Flanges available for all popular motors / gearboxes
- PMI Rail inside & outside unit
- Sealed unit
- Built in the UK



MTZ SERIES

SUITED TO Z AXIS MOUNTING

- Internally guided with PMI Rail
- Built in the UK
- Externally Guided version available
- Ability to connect the Motor directly to the carriage assembly

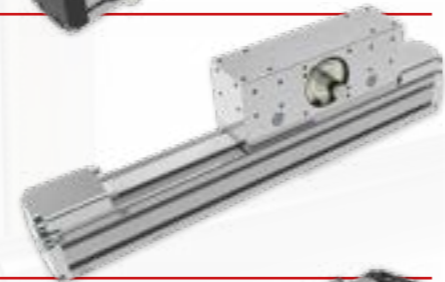

MTF SERIES

INTERNALLY GUIDED

- High loads & speeds
- Extremely compact
- Simple to mount
- Any length of stroke available up to 18 metres
- PMI Rail inside unit
- Built in the UK
- Sealed unit



CTJ SERIES

INTERNALLY GUIDED

- High accuracy
- Simple motor mounting option
- Custom stroke length
- Sealed unit
- Built in the UK
- Available with shock absorbers and built in dead stops



Ballscrew Driven Type

MTV SERIES

INTERNALLY GUIDED

- High loads
- High accuracy
- Modular mounting brackets available
- Ability to be manufactured to give exacting lengths of travel



CTV SERIES

INTERNALLY GUIDED

- High accuracy
- Simple motor mounting option
- Custom stroke length
- Sealed unit
- Built in the UK
- Available with shock absorbers and built in dead stops



Accessories

DRIVES & CONTROLS



COMPLETE YASKAWA RANGE

- Servo Motors
- System Interfaces
- PLC Linear Control Systems
- Complete systems specified in-house



GEARBOXES

WITTENSTEIN ALPHA LINE

- Optimal flexibility
- Proven reliability
- High quality & competitive price
- World-wide support



COUPLINGS

WIDE VARIETY

- Elastomer types
- Metal bellow types
- Oldham types



CONNECTING RODS

VARIETY OF MATERIALS

- Custom lengths
- Overcomes possible misalignment
- Custom materials to suit all types of application



AIR PREPARATION

LARGE UK STOCK

- M5, 1/8", 1/4", 3/8", 1/2" 3/4" 1" BSP FRL
- Precision Regulators
- Soft Start Dump Valve
- Electro Pneumatic Regulator
- Backflow Regulators
- Digital Pressure Switch Option
- Precision Filter - Water Separator
- Boxed Set-Inc Shut-Off
- High Pressure Regulators (35 Bar)



CYLINDERS BUILT IN THE UK

SAMEDAY VDMA AVAILABLE

- Profile & Tie Rod Manufactured In UK 32-Ø200 (ISO 15552) - **MCQI2**
- Compact VDMA Manufactured In UK (ISO 21287) - **MCJI**
- Round-line Mini ISO With Stainless Body Manufactured In UK (IS6432) - **MCMI**
- All Magnetic As Standard

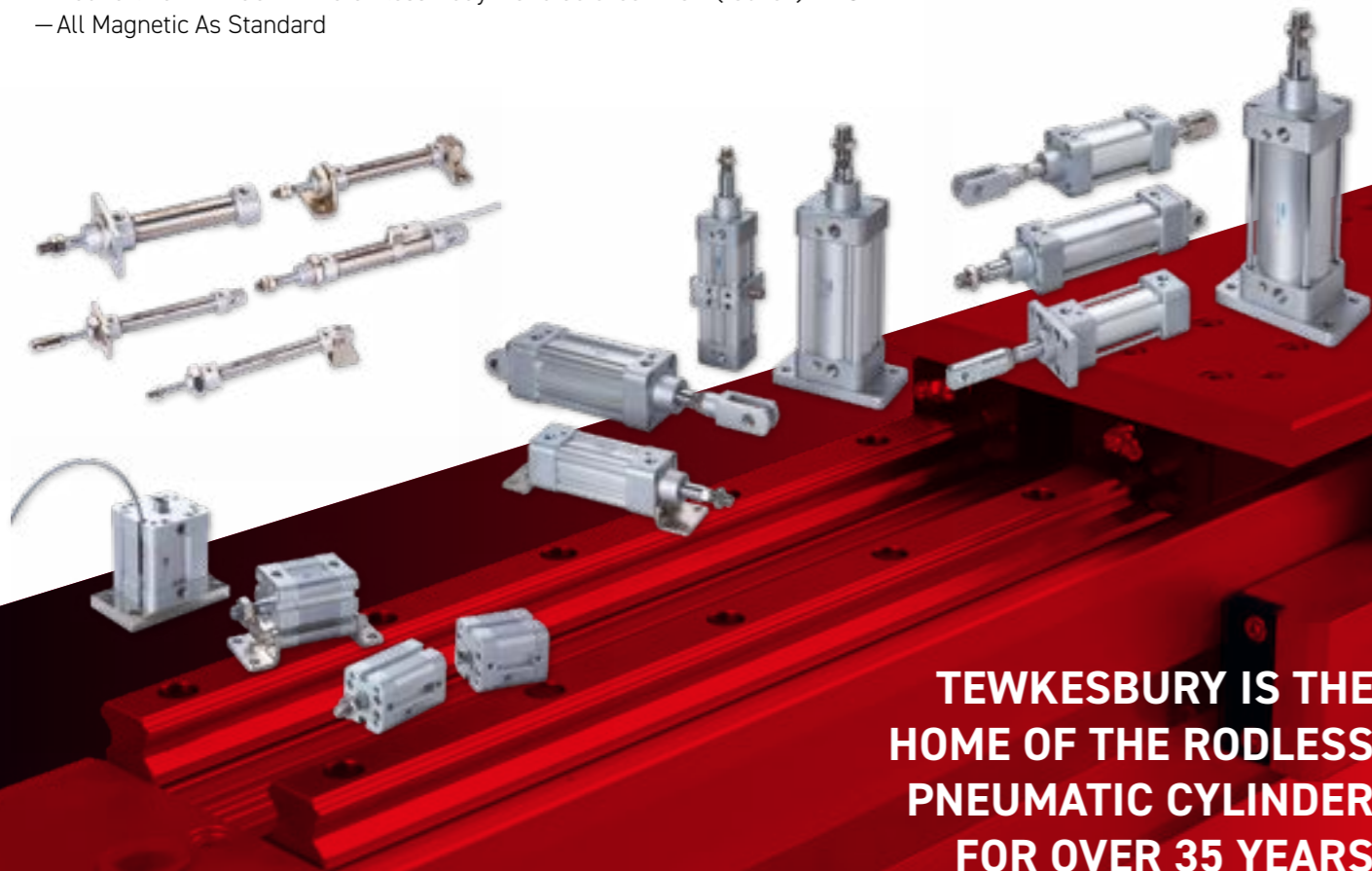

TEWKESBURY IS THE HOME OF THE RODLESS PNEUMATIC CYLINDER FOR OVER 35 YEARS

CYLINDERS & SLIDE UNITS



SOLENOID & MECHANICAL VALVES



ACCESSORIES

PISCO Fittings & Tube



Shuttle & QEV



Shock Absorbers



Air Boosters



GRIPPERS & ROTARY ACTUATORS

MCHX



MCHC



MCHD



MCHG2



MCHJ



MEHC



MCRQ



MCRD



ELECTRIC UNITS

PNCE Electric Rod Cylinder



MESS2/MESH2 Electric Slide Units



ENGINEERING FOR ALL APPLICATIONS

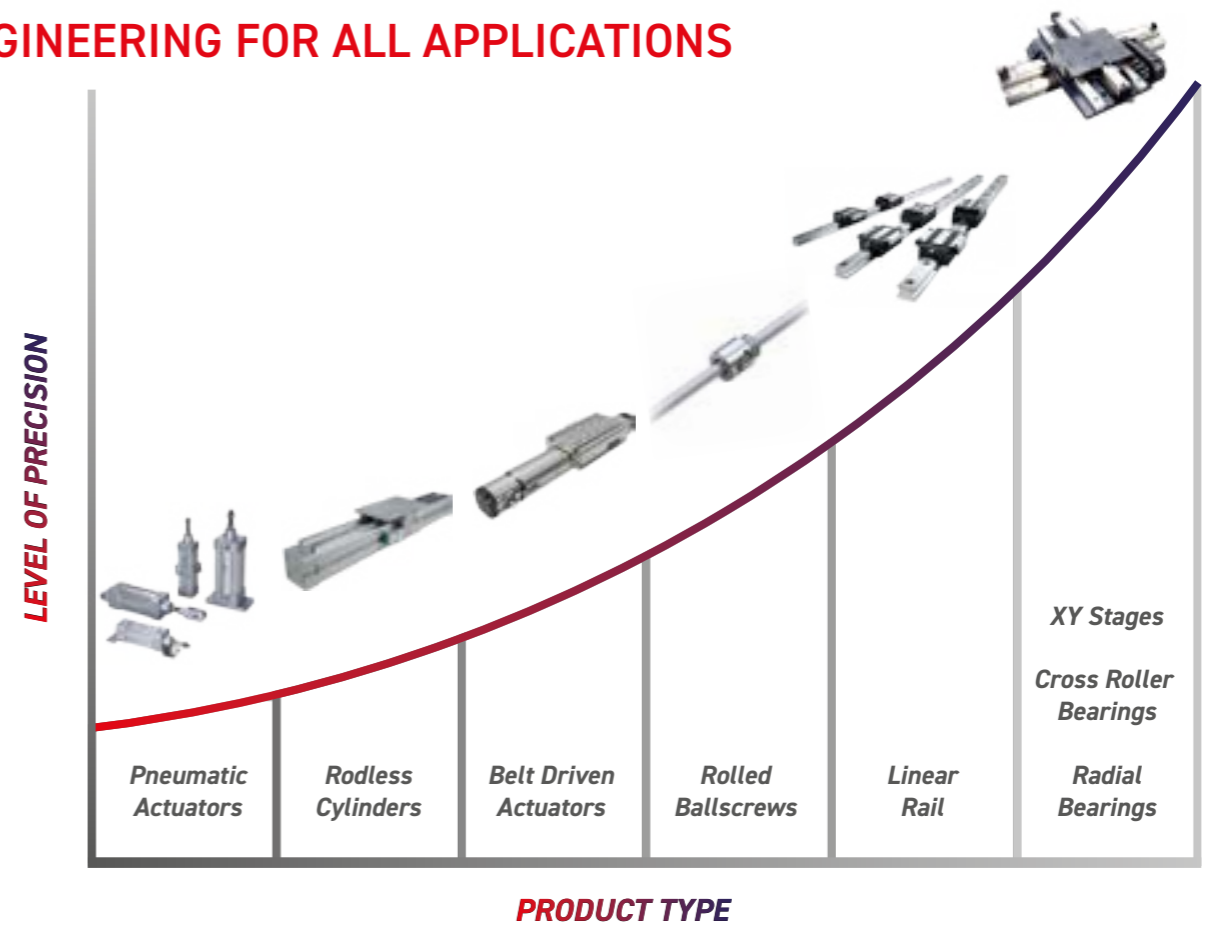

APPLICATION EXAMPLES



CORE CAPABILITIES

- Sameday Cylinder build
- In-house Ballscrew machining
- Weekly deliveries from Taiwan factory
- In-house CAD design
- ISO 9001:2015 status



THE DYNAMICS OF MOVEMENT

We are a company driven by innovation and quality. Our commitment to service and technical expertise is second to none and that is why our products are specified, day in day out, across a variety of industry sectors, including:

- AUTOMOTIVE
- PHARMACEUTICAL
- FOOD & FOOD PROCESSING
- INDUSTRIAL
- ELECTRONICS
- PACKAGING & PRINTING
- STEEL & ALUMINIUM
- TEXTILES & LEATHER
- WOODWORKING
- CERAMICS



HOME OF THE RODLESS
PNEUMATIC CYLINDER
FOR MORE THAN 30 YEARS

WHAT OUR CUSTOMERS SAY

"We received a rodless cylinder from Matarara. We are very pleased with it - it fitted perfectly and with their three day lead time - much better than the 'official' replacement which would have taken at least five weeks and at three times the cost. So thanks, and great service!"

Robin Pocock - Airsprung Beds

"The level of personal service I receive from Matarara really makes a difference. Their blend of professionalism and flexibility is refreshing."

**Mick McHale -
James Mae Industries**

"It's essential that supply partners can deliver the expertise we need. Matarara give me that confidence and back it up with a very hands-on approach to service and support."

Adam Boote - Layton Technologies

To find out how we can help you, simply get in touch with our expert team on sales@matarauk.co.uk



Matarara UK Limited
5801 Shannon Place,
Tewkesbury Business Park,
Tewkesbury,
Gloucestershire,
GL20 8SL

Tel: 44 (0) 1684 850000
Fax: 44 (0) 1684 850066

sales@matarauk.co.uk
www.matarara.com



V1.0
© Matarara 2018

