

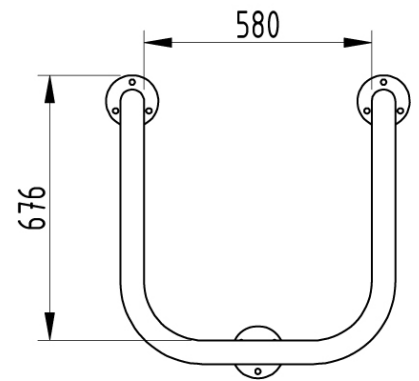

ACP1 Column Protector

60mm Diameter

Galvanised or Galvanised & Colour

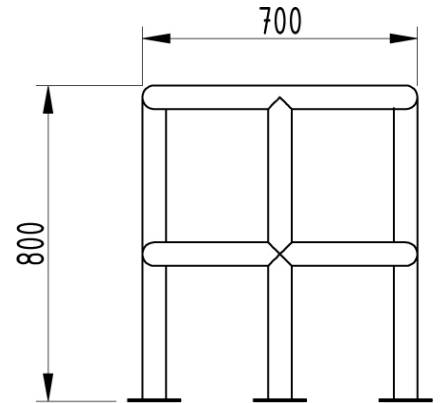

Functional and robust in design, AUTOPA's range of column protectors are designed to protect corners, columns, and other vulnerable pillars from vehicle damage in a busy industrial environment. Our Column Protectors are manufactured from mild steel and galvanised to ensure their longevity. Suitable for both internal and external use.

Column Protectors are available in galvanised, galvanised & coated (RAL/BS numbers must be specified at time of order), or galvanised and coated yellow, complete with black reflective bands (5 x 100mm width bands).

Part Number	Description	Weight (kg)
138 177 710	Galvanised, Concrete In	28kg
138 177 705	Galvanised, Bolt Down	25kg
138 177 711	Galvanised & Colour, Concrete In	28kg
138 177 706	Galvanised & Colour, Bolt Down	25kg
138 177 710BY	Galvanised & Colour Yellow with Black Bands, Concrete In	28kg
138 177 705BY	Galvanised & Colour Yellow with Black Bands, Bolt Down	25kg

Product details

- 800mm x 700mm (Height x External Width)
- 60mm Diameter Tube
- 580mm (Internal Width)
- Concrete in 300mm (Below Ground)

Installation & use

Bolt down to a suitable concrete surface.
 Telescopic, removable and concrete in are supplied with welded fixing spikes to ensure firm ground anchorage into concrete.
 Telescopic, removable and concrete in require a suitable excavated hole for installing into concrete.
 Products are guaranteed for 12 months (if installed and used correctly).



www.autopa.co.uk
 +44 (0)1788 550556

AUTOPA Limited
 Cottage Leap, Rugby, Warwickshire CV21 3XP

