

DYMET ALLOYS SAW TIPS

Dymet Alloys offer a range of 'Ready to Braze' Tungsten Carbide Saw Tips.

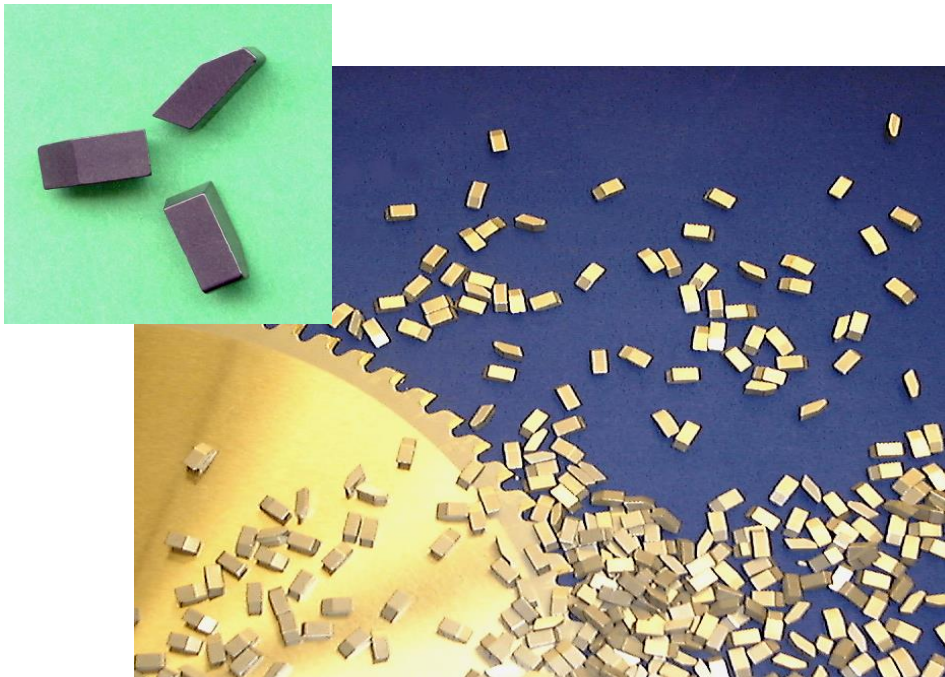

- ◆ Grades:
Standard 6% cobalt.
Steel cutting and alternative grades available to special order.

- ◆ Quantity:
Saw Tips are available in multiples of 500-off.
Please note our minimum order value £50-00.

- ◆ Sizes:
Kerf sizes in the price list are usually ex-stock.
Other sizes available to special order, price on request.

Dymets Alloys specialise in manufacturing tungsten carbide products to individual customer specification. Other products / applications include Wear blocks, Bandsaw blade guides, shaped tips for cutter blades, cutters / burs and drills.



DYMET ALLOYS SAW TIP PRICE LIST

Grades:

Standard 6% cobalt.
Steel cutting and alternative grades available to special order.

Quantity:

Saw Tips are available in multiples of 500-off.
Please note our minimum order value £50-00.

A-SERIES SAW TIPS READY TO BRAZE (dimensions in mm)

DYMET CODE	Length	KERF Width	Thickness	500-2000	2500-5000	>5500
A-085	9.5	2.1	3.2		POA	
A-095	9.5	2.4	3.2		POA	
A-105	9.5	2.7	3.2		POA	
A-115	9.5	2.9	3.2		POA	
A-125	9.5	3.2	3.2		POA	
A-135	9.5	3.4	3.2		POA	
A-145	9.5	3.7	3.2		POA	
A-155	9.5	3.9	3.2		POA	
A-165	9.5	4.2	3.2	£0.244	£0.217	£0.208
A-175	9.5	4.5	3.2		POA	
A-185	9.5	4.7	3.2		POA	
A-195	9.5	5	3.2		POA	
A-205	9.5	5.2	3.2	£0.274	£0.247	£0.239
A-215	9.5	5.5	3.2		POA	
A-225	9.5	5.7	3.2	£0.289	£0.262	£0.254

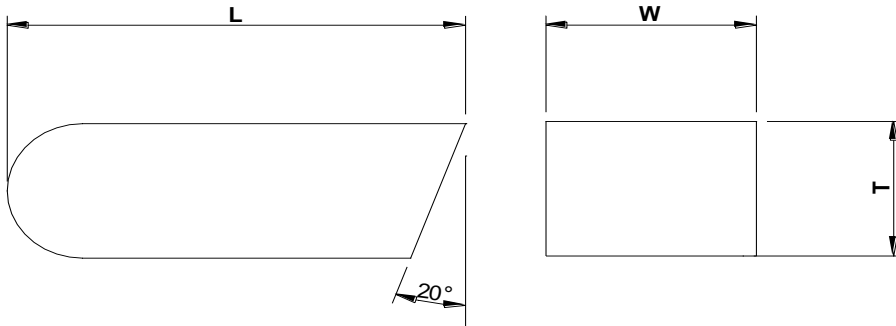



DYMET ALLOYS SAW TIP PRICE LIST

Grades:

Standard 6% cobalt.
Steel cutting and alternative grades available to special order.

Quantity:

Saw Tips are available in multiples of 500-off.
Please note our minimum order value £50-00.

B-SERIES SAW TIPS READY TO BRAZE (dimensions in mm)

DYMET CODE	Length	KERF Width	Thickness	500-2000	2500-5000	>5500
B-085	8	2.1	2.6	POA		
B-095	8	2.4	2.6	POA		
B-105	8	2.7	2.6	POA		
B-115	8	2.9	2.6	POA		
B-125	8	3.2	2.6	POA		
B-135	8	3.4	2.6	POA		
B-145	8	3.7	2.6	POA		
B-155	8	3.9	2.6	£0.198	£0.172	£0.163
B-165	8	4.2	2.6	POA		
B-175	8	4.5	2.6	£0.211	£0.184	£0.176
B-185	8	4.7	2.6	£0.215	£0.188	£0.180
B-195	8	5	2.6	£0.221	£0.194	£0.186
B-205	8	5.2	2.6	POA		
B-215	8	5.5	2.6	£0.232	£0.205	£0.197
B-225	8	5.7	2.6	POA		

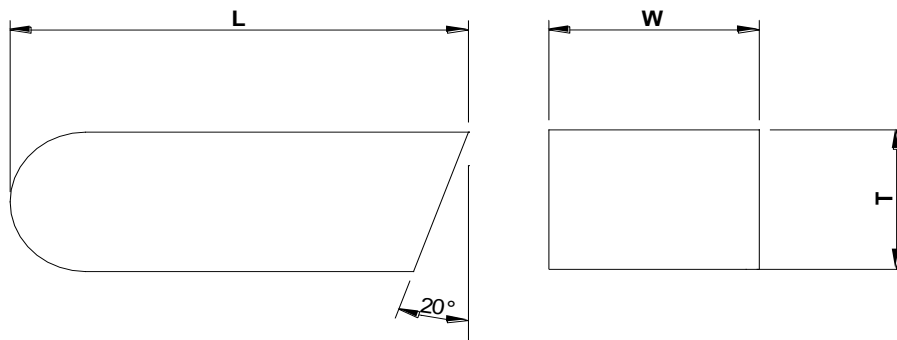



DYMET ALLOYS SAW TIP PRICE LIST

Grades:

Standard 6% cobalt.
Steel cutting and alternative grades available to special order.

Quantity:

Saw Tips are available in multiples of 500-off.
Please note our minimum order value £50-00.

F-SERIES SAW TIPS READY TO BRAZE (dimensions in mm)

DYMET CODE	Length	KERF Width	Thickness	500-2000	2500-5000	>5500
F-085	9.5	2.1	3.2	POA		
F-095	9.5	2.4	3.2	POA		
F-105	9.5	2.7	3.2	POA		
F-115	9.5	2.9	3.2	POA		
F-125	9.5	3.2	3.2	POA		
F-135	9.5	3.4	3.2	POA		
F-145	9.5	3.7	3.2	£0.165	£0.140	£0.134
F-155	9.5	3.9	3.2	£0.170	£0.146	£0.140
F-165	9.5	4.2	3.2	POA		
F-175	9.5	4.5	3.2	£0.187	£0.163	£0.157
F-185	9.5	4.7	3.2	£0.193	£0.168	£0.162
F-195	9.5	5	3.2	POA		
F-205	9.5	5.2	3.2	£0.207	£0.183	£0.177
F-215	9.5	5.5	3.2	£0.216	£0.191	£0.185
F-225	9.5	5.7	3.2	£0.221	£0.197	£0.191
F-235	9.5	6	3.2	£0.230	£0.205	£0.199
F-245	9.5	6.2	3.2	POA		
F-255	9.5	6.5	3.2	POA		
F-265	9.5	6.7	3.2	POA		
F-275	9.5	7	3.2	POA		
F-285	9.5	7.2	3.2	POA		
F-295	9.5	7.5	3.2	POA		
F-305	9.5	7.7	3.2	POA		
F-315	9.5	8	3.2	POA		

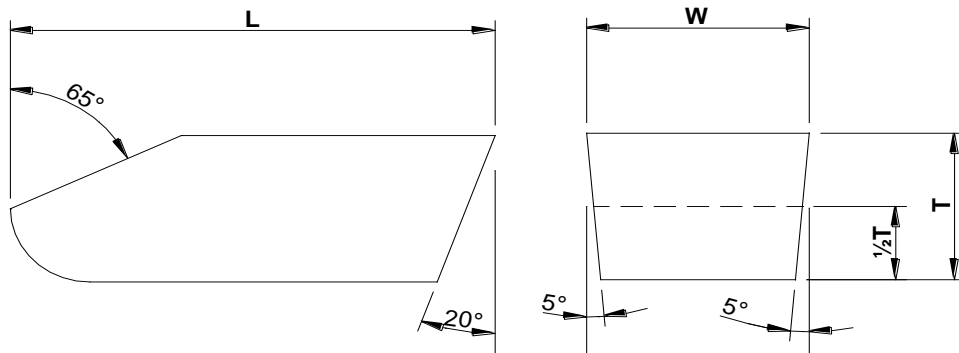



DYMET ALLOYS SAW TIP PRICE LIST

Grades:

Standard 6% cobalt.
Steel cutting and alternative grades available to special order.

Quantity:

Saw Tips are available in multiples of 500-off.
Please note our minimum order value £50-00.

H-SERIES SAW TIPS READY TO BRAZE (dimensions in mm)

DYMET CODE	Length	KERF Width	Thickness	500-2000	2500-5000	>5500
H-085	8	2.1	2.6	POA		
H-095	8	2.4	2.6	POA		
H-105	8	2.7	2.6	POA		
H-115	8	2.9	2.6	£0.117	£0.092	£0.086
H-125	8	3.2	2.6	£0.122	£0.098	£0.092
H-135	8	3.4	2.6	POA		
H-145	8	3.7	2.6	£0.132	£0.107	£0.102
H-155	8	3.9	2.6	£0.136	£0.111	£0.105
H-165	8	4.2	2.6	£0.142	£0.117	£0.111
H-175	8	4.5	2.6	£0.148	£0.123	£0.117
H-185	8	4.7	2.6	£0.152	£0.127	£0.121
H-195	8	5	2.6	£0.158	£0.133	£0.127
H-205	8	5.2	2.6	£0.162	£0.137	£0.131
H-215	8	5.5	2.6	£0.167	£0.143	£0.137
H-225	8	5.7	2.6	£0.171	£0.147	£0.141
H-235	8	6	2.6	POA		
H-245	8	6.2	2.6	POA		
H-255	8	6.5	2.6	POA		
H-265	8	6.7	2.6	POA		
H-275	8	7	2.6	POA		
H-285	8	7.2	2.6	POA		
H-295	8	7.5	2.6	POA		
H-305	8	7.7	2.6	POA		
H-315	8	8	2.6	POA		

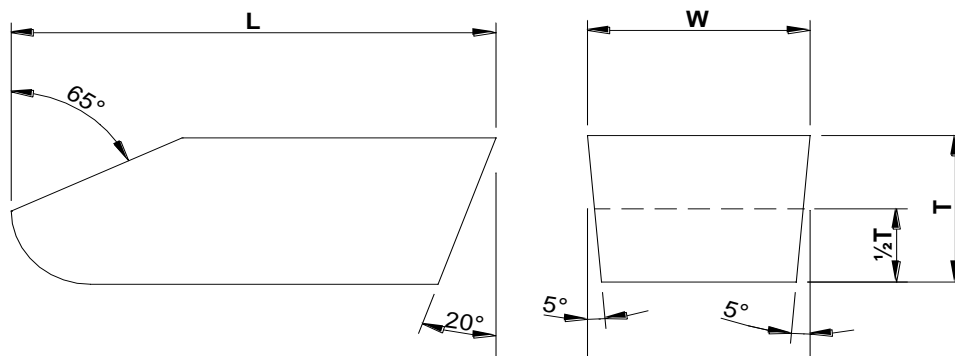



DYMET ALLOYS SAW TIP PRICE LIST

Grades:

Standard 6% cobalt.
Steel cutting and alternative grades available to special order.

Quantity:

Saw Tips are available in multiples of 500-off.
Please note our minimum order value £50-00.

G-SERIES SAW TIPS READY TO BRAZE (dimensions in mm)

DYMET CODE	Length	KERF Width	Thickness	500-2000	2500-5000	>5500
G-085	8.7	2.1	2.6	POA		
G-095	8.7	2.4	2.6	POA		
G-105	8.7	2.7	2.6	POA		
G-115	8.7	2.9	2.6	POA		
G-125	8.7	3.2	2.6	£0.187	£0.160	£0.152
G-135	8.7	3.4	2.6	POA		
G-145	8.7	3.7	2.6	£0.197	£0.171	£0.162
G-155	8.7	3.9	2.6	£0.202	£0.175	£0.167
G-165	8.7	4.2	2.6	£0.208	£0.181	£0.173
G-175	8.7	4.5	2.6	£0.215	£0.188	£0.180
G-185	8.7	4.7	2.6	£0.219	£0.192	£0.184
G-195	8.7	5	2.6	£0.226	£0.199	£0.191
G-205	8.7	5.2	2.6	£0.230	£0.203	£0.195
G-215	8.7	5.5	2.6	£0.236	£0.210	£0.201
G-225	8.7	5.7	2.6	£0.241	£0.214	£0.206

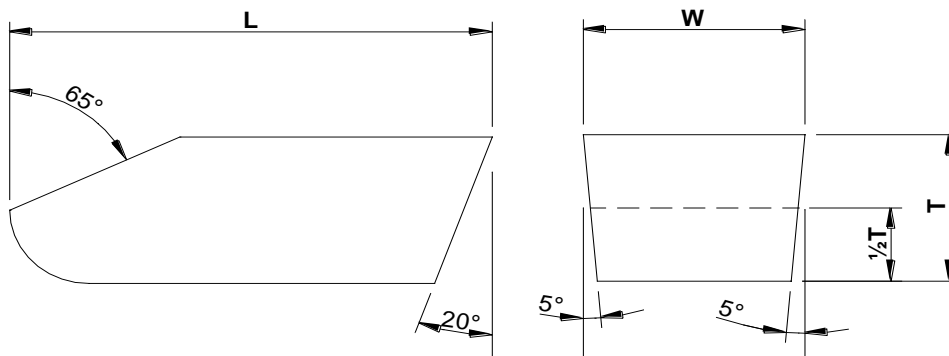



DYMET ALLOYS SAW TIP PRICE LIST

Grades:

Standard 6% cobalt.
Steel cutting and alternative grades available to special order.

Quantity:

Saw Tips are available in multiples of 500-off.
Please note our minimum order value £50-00.

J-SERIES SAW TIPS READY TO BRAZE (dimensions in mm)

DYMET CODE	Length	KERF Width	Thickness	500-2000	2500-5000	>5500
J-085	8	2.1	2	POA		
J-095	8	2.4	2	POA		
J-105	8	2.7	2	POA		
J-115	8	2.9	2	POA		
J-125	8	3.2	2	POA		
J-135	8	3.4	2	£0.114	£0.089	£0.083
J-145	8	3.7	2	£0.118	£0.094	£0.088
J-155	8	3.9	2	£0.122	£0.097	£0.091
J-165	8	4.2	2	£0.126	£0.102	£0.096
J-175	8	4.5	2	£0.131	£0.106	£0.100
J-185	8	4.7	2	£0.134	£0.110	£0.104
J-195	8	5	2	£0.139	£0.114	£0.108
J-205	8	5.2	2	£0.142	£0.118	£0.112
J-215	8	5.5	2	£0.147	£0.122	£0.116
J-225	8	5.7	2	POA		
J-235	8	6	2	POA		
J-245	8	6.2	2	POA		
J-255	8	6.5	2	POA		
J-265	8	6.7	2	POA		
J-275	8	7	2	POA		
J-285	8	7.2	2	POA		
J-295	8	7.5	2	POA		
J-305	8	7.7	2	POA		
J-315	8	8	2	POA		

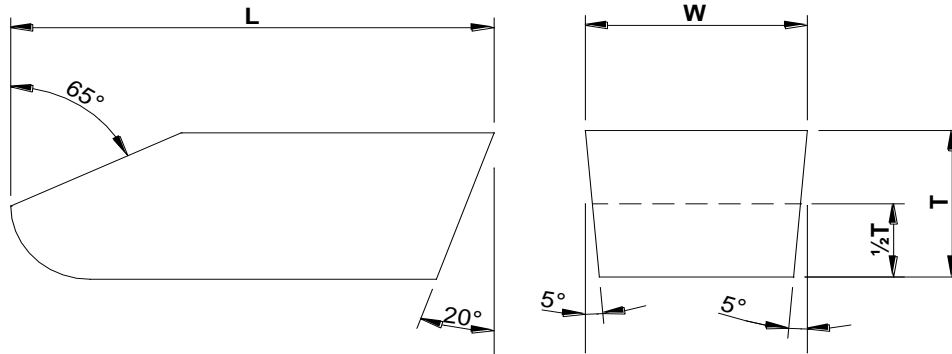



DYMET ALLOYS SAW TIP PRICE LIST

Grades:

Standard 6% cobalt.
Steel cutting and alternative grades available to special order.

Quantity:

Saw Tips are available in multiples of 500-off.
Please note our minimum order value £50-00.

P-SERIES SAW TIPS READY TO BRAZE (dimensions in mm)

DYMET CODE	Length	KERF Width	Thickness	500-2000	2500-5000	>5500
P-125	11	3.2	3.6	POA		
P-135	11	3.4	3.6	POA		
P-145	11	3.7	3.6	POA		
P-155	11	3.9	3.6	£0.199	£0.174	£0.168
P-165	11	4.2	3.6	£0.209	£0.185	£0.179
P-175	11	4.5	3.6	£0.220	£0.195	£0.189
P-185	11	4.7	3.6	£0.227	£0.202	£0.196
P-195	11	4.9	3.6	£0.234	£0.210	£0.204
P-205	11	5.2	3.6	£0.245	£0.220	£0.214
P-215	11	5.4	3.6	£0.252	£0.227	£0.221
P-225	11	5.7	3.6	£0.263	£0.238	£0.232
P-235	11	6	3.6	£0.273	£0.249	£0.243
P-245	11	6.2	3.6	£0.281	£0.256	£0.250
P-255	11	6.5	3.6	£0.291	£0.267	£0.261
P-265	11	6.7	3.6	POA		
P-275	11	7	3.6	£0.309	£0.284	£0.278
P-285	11	7.2	3.6	£0.316	£0.291	£0.286
P-295	11	7.5	3.6	£0.327	£0.302	£0.296
P-305	11	7.8	3.6	£0.338	£0.313	£0.307
P-315	11	8	3.6	£0.345	£0.320	£0.314
P-325	11	8.3	3.6	£0.355	£0.331	£0.325
P-335	11	8.5	3.6	£0.362	£0.338	£0.332

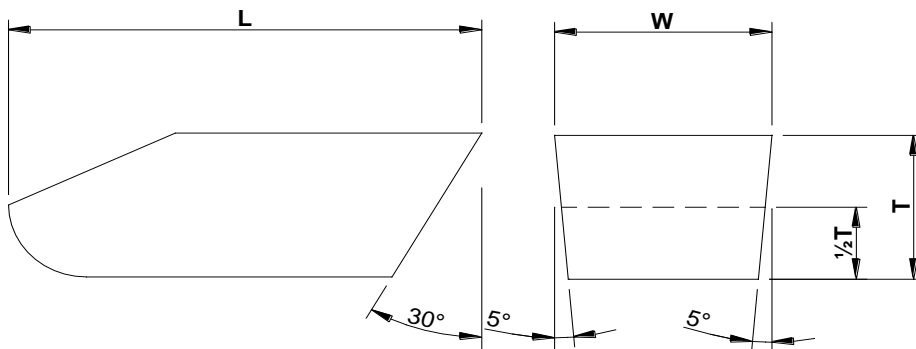



DYMET ALLOYS SAW TIP PRICE LIST

Grades:

Standard 6% cobalt.
Steel cutting and alternative grades available to special order.

Quantity:

Saw Tips are available in multiples of 500-off.
Please note our minimum order value £50-00.

N-SERIES SAW TIPS READY TO BRAZE (dimensions in mm)

DYMET CODE	Length	KERF Width	Thickness	500-2000	2500-5000	>5500
N-085	9.5	2.1	3.2		POA	
N-095	9.5	2.4	3.2		POA	
N-105	9.5	2.7	3.2		POA	
N-115	9.5	2.9	3.2		POA	
N-125	9.5	3.2	3.2		POA	
N-135	9.5	3.4	3.2		POA	
N-145	9.5	3.7	3.2		POA	
N-155	9.5	3.9	3.2		POA	
N-165	9.5	4.2	3.2		POA	
N-175	9.5	4.5	3.2		POA	
N-185	9.5	4.7	3.2		POA	
N-195	9.5	5	3.2		POA	
N-205	9.5	5.2	3.2		POA	
N-215	9.5	5.5	3.2		POA	
N-225	9.5	5.7	3.2		POA	
N-235	9.5	6	3.2		POA	
N-245	9.5	6.2	3.2		POA	
N-255	9.5	6.5	3.2		POA	
N-265	9.5	6.7	3.2		POA	
N-275	9.5	7	3.2		POA	
N-285	9.5	7.2	3.2		POA	
N-295	9.5	7.5	3.2		POA	
N-305	9.5	7.8	3.2		POA	
N-315	9.5	8	3.2		POA	

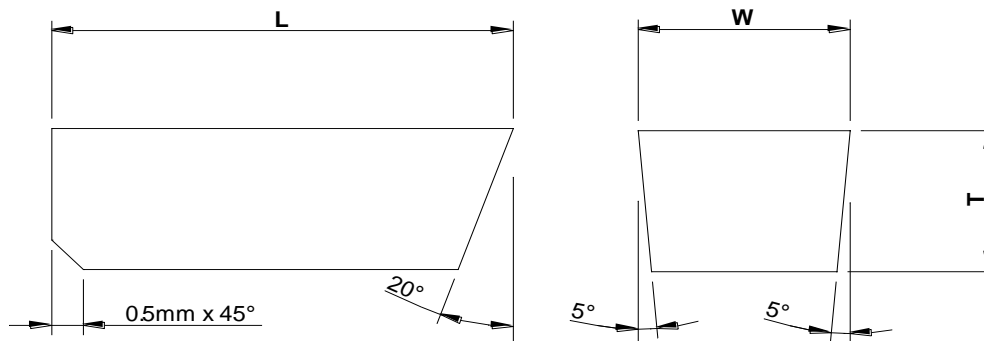



DYMET ALLOYS SAW TIP PRICE LIST

Grades:

Standard 6% cobalt.
Steel cutting and alternative grades available to special order.

Quantity:

Please note our minimum order value £50-00.

GROOVER TIPS READY TO BRAZE

DYMET CODE	Length	KERF Width	Thickness	0 - 100	101 - 500	>501
A-0200	12.8	2MM	4.3	£0.345	£0.246	£0.198
A-0300	12.8	3MM	4.3	£0.397	£0.298	£0.249
A-0317	12.8	1/8"	4.3	£0.403	£0.305	£0.256
A-0400	12.8	4MM	4.3	£0.449	£0.350	£0.301
A-0476	12.8	3/16"	4.3	£0.488	£0.389	£0.341
A-0500	12.8	5MM	4.3	£0.501	£0.402	£0.353
A-0600	12.8	6MM	4.3	£0.552	£0.454	£0.405
A-0635	12.8	1/4"	4.3	£0.570	£0.472	£0.423
A-0700	12.8	7MM	4.3	£0.604	£0.505	£0.457
A-0794	12.8	5/16"	4.3	£0.653	£0.554	£0.505
A-0953	12.8	3/8"	4.3	£0.734	£0.635	£0.586
A-1000	12.8	10MM	4.3	£0.760	£0.661	£0.612
A-1111	12.8	7/16"	4.3	£0.817	£0.718	£0.669
A-1200	12.8	12MM	4.3	£0.863	£0.765	£0.716
A-1270	12.8	1/2"	4.3	£0.900	£0.801	£0.752
A-1300	12.8	13MM	4.3	£0.915	£0.816	£0.768
A-1429	12.8	9/16	4.3	£0.982	£0.883	£0.835
A-1588	12.8	5/8"	4.3	£1.066	£0.967	£0.918
A-1748	12.8	11/16"	4.3	£1.146	£1.048	£0.999
A-1800	12.8	18MM	4.3	£1.174	£1.076	£1.027
A-1905	12.8	3/4"	4.3	£1.229	£1.130	£1.081

Other sizes are available to special order. Price on application.

