



SOHO



INDUSTRY



E-MEDICAL



EMERGENCY

Sentinel Pro



ONLINE



Tower



1:1 700-3000 VA



USB
plug



GS Nemko
certified



Supercaps
UPS



Plug & Play
installation



HIGHLIGHTS

- Power factor 0.9
- Operating flexibility
- Emergency function
- Battery optimisation
- Runtime expandability
- Low noise level

Sentinel Pro has a unique and modern design and improved performance developed by the Riello UPS research and development team. Sentinel Pro uses on-line double conversion technology, resulting in the highest levels of reliability and maximum protection for critical loads such as servers, and IT and voice/data applications.

For business continuity applications requiring long battery runtimes, battery autonomy can be extended up to several hours using ER models fitted with more powerful battery chargers. The front display panel has been entirely redesigned, adding an LCD display that

shows the input and output voltages, battery readings and UPS operating status information. The inverter and the microprocessor control stage has been completely redesigned to provide increased efficiency and greater configuration options. Maximum expandability: the Sentinel Pro is supplied as standard with a USB port and an expansion slot for protocol conversion or relay contacts boards.

With energy savings in mind, Sentinel Pro is also fitted with a shut-off button to reduce energy consumption to zero during prolonged periods of inactivity (ECO LINE). Sentinel Pro is available in 700 VA, 1000 VA, 1500 VA, 2200 VA and 3000 VA models.

Operating flexibility

Different operating modes that can be programmed according to user requirements and the load to be powered have been introduced in order to reduce energy consumption.

- **On line:** maximum load protection and output voltage waveform quality
- **Eco Mode:** the UPS uses line interactive technology, with the load powered by the mains, reducing consumption and thus improving efficiency (up to 98%).
- **Smart Active Mode:** the UPS automatically selects on-line or line interactive operation, depending on the quality of the mains supply, checking the number, frequency and type of disturbances present.
- **Stand by Off (emergency):** the UPS supplies the load only when the mains fails. The inverter begins working with a progressive start-up sequence to prevent inrush currents.
- **Frequency converter** operation (50 or 60 Hz).



Emergency function

This configuration ensures the operation of emergency systems that must be supplied in the event of a mains power failure, such as emergency lighting, fire detection/ extinguishing systems and alarms. When the mains power supply fails, the inverter begins powering the loads with a progressive start-up (Soft Start) in order to prevent overload. Sentinel Pro is compliant for installation in medium-voltage transformer rooms in accordance with applicable legislation, for the power supply with reserve charge of medium-voltage coils.

Battery optimisation

The Sentinel Pro range has a deep discharge protection device to optimise battery life. Periodically the UPS carries out a battery efficiency test (which can also be manually activated); its wide input voltage tolerance range helps to reduce battery usage and maintain performance over time.

Runtime expandability

Optional battery extension packs can be connected to increase UPS runtime. In addition the Sentinel Pro range includes ER versions with no internal batteries and more powerful battery chargers for longer runtimes.

Low noise level

Thanks to the use of high frequency components and load-based fan speed control, the noise produced by the UPS is less than 40 dBA.

Features

- Filtered, stabilised and reliable voltage: double conversion on-line technology (VFI compliant with IEC 62040-3) with filters for the suppression of atmospheric disturbances.
- High overload capability (up to 150%)
- Programmable Auto-restart when mains is restored
- Battery start-up (Cold Start)

DETAILS

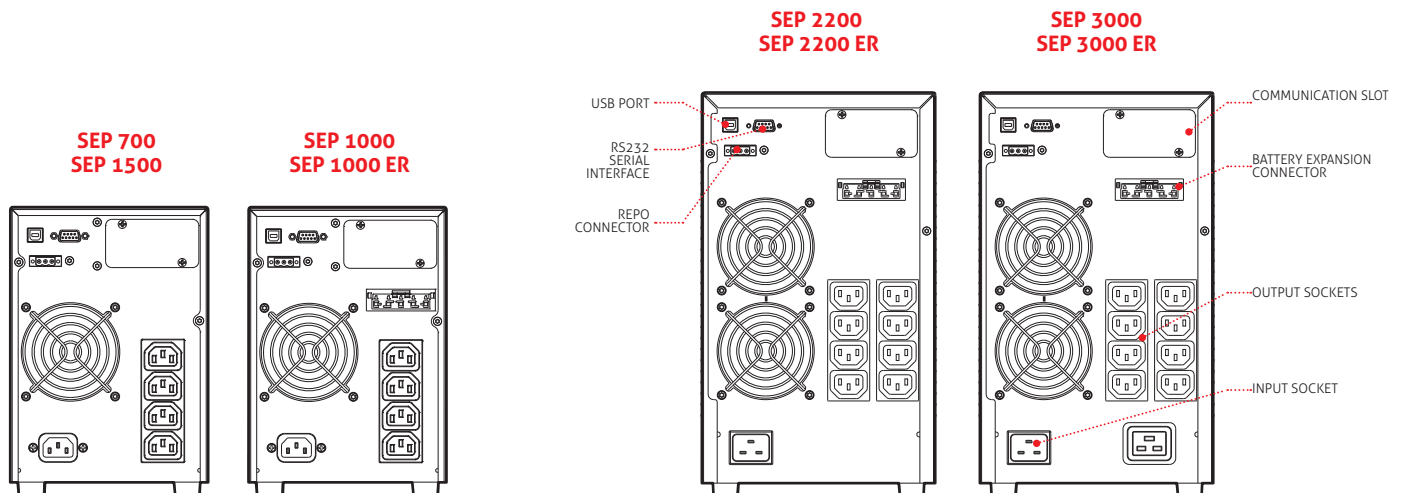

- Power factor correction (UPS input power factor, close to 1)
- Wide input voltage tolerance range (from 140 V to 276 V) without battery intervention.
- Runtime extendable up to several hours
- Fully configurable using UPS Tools configuration software
- Highly reliable batteries (automatic and manually-activated battery test)
- High level of UPS reliability (total microprocessor control)
- Low impact on the mains (sinusoidal take up).

Advanced communications

- Multi-platform communication for all operating systems and network environments: PowerShield³ supervision and shutdown software for Windows operating systems 10, 8, 7, Hyper-V, 2016, 2012, and previous versions, Mac OS X,

- Linux, VMWare ESXi, Citrix XenServer and other Unix operating systems
- UPS Tools configuration and customisation software supplied as standard
- RS232 serial port and opto-isolated contacts
- USB port
- Slot for communications boards.

2-YEAR WARRANTY

OPTIONS

SOFTWARE

PowerShield³
PowerNetGuard

ACCESSORIES

NETMAN 204
MULTICOM 302
MULTICOM 352

MULTICOM 372
MULTICOM 384
MULTI I/O
MULTIPANEL
Manual Bypass 16 A
Automatic Bypass 16 A

BATTERY BOX

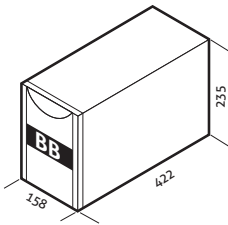
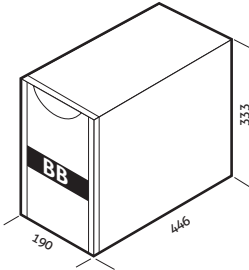
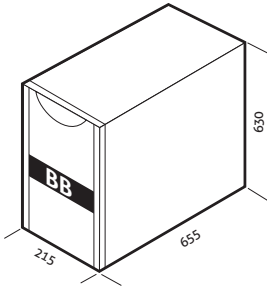
MODELS	BB SEP 36-A3 / BB SEP 36-M1	BB SEP 72-A3 / BB SEP 72-M1	BB SEP 36-B1 / BB SEP 72-B1
Dimensions (mm)			

MODELS	SEP 700	SEP 1000	SEP 1000 ER	SEP 1500	SEP 2200	SEP 2200 ER	SEP 3000	SEP 3000 ER
POWER	700 VA/630 W	1000 VA/900 W		1500 VA/1350 W	2200 VA/1980 W		3000 VA/2700 W	
INPUT								
Nominal voltage	220-230-240 Vac							
Voltage range without battery intervention	140 Vac < Vin < 276 Vac @50% load / 184 Vac < Vin < 276 Vac @ 100% load							
Voltage tolerance	230 Vac ± 20%							
Maximum permitted voltage	300 Vac							
Nominal frequency	50/60 Hz							
Frequency range	50 Hz ± 5% / 60 Hz ± 5%							
Power factor	> 0.99							
Current distortion	≤7%							
BYPASS								
Voltage tolerance	180 - 264 Vac							
Frequency tolerance	Frequency selected (from ±1.5Hz to ±5Hz configurable)							
Overload Times	125% for 5 seconds, 150% for 1 second							
OUTPUT								
Voltage distortion with linear load / with non-linear load	< 2% / < 4%							
Frequency	Selectable: 50 Hz or 60 Hz or self-learning							
Static variation	± 1%							
Dynamic variation	≤ 5% in 20 msec.							
Waveform	Sinusoidal							
Current crest factor	3 : 1							
Efficiency ECO and Smart Active Modes	98%							
BATTERIES								
Type	VRLA AGM maintenance-free lead based; Supercaps							
Recharge time	2-4 hours	N.A.		2-4 hours	N.A.		2-4 hours	N.A.
OTHER FEATURES								
Net weight (kg)	10.9	13.3	7	14.8	25.6	14	28	15
Gross weight (kg)	12.5	14.9	8.6	15.5	28.8	17	31.2	18
Dimensions (WxDxH) (mm)	158 x 422 x 235				190 x 446 x 333			
Packaging dimensions (WxDxH) (mm)	245 x 500 x 340				325 x 585 x 470			
Protection against overvoltage	300 joules							
Protections	Overcurrent - short-circuit - overvoltage - undervoltage - temperature - excessive low battery							
Communications	USB / DB9 with RS232 and contacts / Slot for communications interface							
Input plugs	1 IEC 320 C14				1 IEC 320 C20			
Output sockets	4 IEC 320 C13				8 IEC 320 C13		8 IEC 320 C13 + 1 IEC 320 C19	
Standards	Safety: EN 62040-1 and Directive 2006/95/EL; EMC: EN 620040-2 and Directives 2004/108/EL							
Operating temperature	0 °C / +40 °C							
Relative humidity	< 95% non-condensing							
Colour	Black							
Noise level at 1 m (ECO Mode)	< 40 dBA							
Standard equipment provided	Power cable, IEC-IEC cable, USB cable, safety manual, quick start guide							