



# 100 Series

## Semi-Automatic Case Erectors

---



### 101/2/3

Each machine can be used either on its own or close-coupled to a case sealer to provide a simple and effective system and is suitable for a range of case sizes; 101 allows for a small range, 102 medium range and 103 a large range for case forming, loading and sealing.



### 121/2/3

These machines can be set to an angled position, which is ideal for products that are unstable such as bags or bottles. The machine incorporates a section of horizontal belt drive so the case is horizontal at entry to the sealer.



### Efficient

Our case formers reduce the time and effort taken to manually erect and load a case and you can also save space and time by eliminating the need to hold pre-erected cases near the packing area.



### Compact

Our machines have a compact footprint and will not take up a great deal of space in your production area. They are fully portable with adjustable legs to enable the tilt angle to be customised.



### Simple to operate

With no need to make any adjustments for size change, they can be set up and running in seconds.



### Low cost of ownership

All Endoline's machines are designed for maximum efficiency and productivity thereby reducing the cost of ownership to a minimum. Our case formers come at a low capital cost and immediate savings can be seen through reduced labour costs and increased packing speeds.





## 100 Series

Semi-Automatic  
Case Erectors

### Options include:

- Locating spacers to secure to a case sealer
- Locking castors

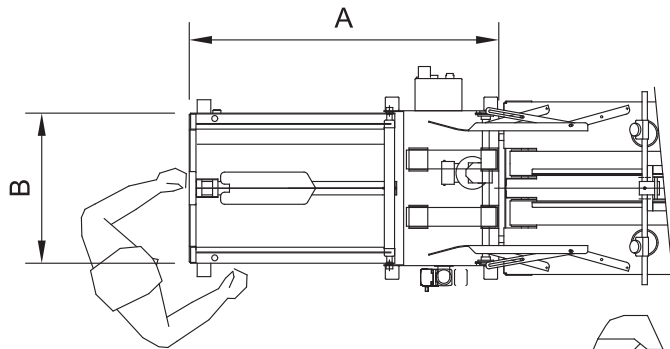

	A	B	C
101	695	482	615-900
102	790	662	625-925
103	900	762	605-905

	A	B	C
121	1155	382	700-980
122	1155	560	700-980
123	1155	660	700-980

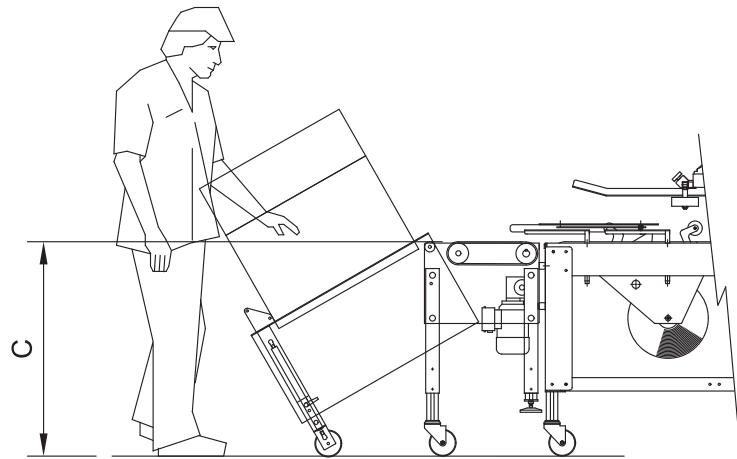

### Case Dimensions (mm).

	Length min/max	Width min/max
101	200/400	120/250
102	200/500	150/400
103	200/600	150/500
121	200/400	120/250
122	200/600	150/400
123	200/600	150/500

### Pneumatics

- 5.5 bar supply pressure

### Machine Finish

- Mild steel powder coated white
- (RAL 9010) or stainless steel

© Endline reserves the right to change specifications without prior notice.

### Endline Machinery Limited

Stratton Business Park, London Road Biggleswade, Bedfordshire SG18 8QB United Kingdom  
Telephone: +44 (0) 1767 316422 Facsimile: +44 (0) 1767 318033 E-mail: sales@endline-automation.com

