



CMR Electrical Ltd  
Bolton House  
Five Chimneys Lane  
Hadlow Down  
East Sussex  
TN22 4DX  
Tel: 01825 733600

# BLDA1-2 Water Leak Detection Manual



# Contents

- 1) *System Overview*
- 2) *Installation*
- 3) *Wiring*
- 4) *Water Solenoid Valve (If Required)*
- 5) *Relay Outputs*
- 6) *Sounder Beacon and SMS Text Messaging*
- 7) *Push Button Description*
- 8) *Display Screens*
- 9) *Overview for setting up the system*
- 10) *Setting up Meter Pulses per Litre*
- 11) *Setting up High and Low maximum allowable litres and time period*
- 12) *Setup the Clock*
- 13) *Set the continuous flow alarm time*
- 14) *Set the High Flow time periods for the day of the week*
- 15) *How to reset the unit after an alarm*
- 16) *Place the unit into a 4-hour SLEEP mode*
- 17) *Water meters*
- 18) *Water meter Installation*

## 1) System Overview

Being fully programmable to suite users' requirements, the unit is connected to a water meter installed to the main incoming water supply and optional shut off valve. This meter can be existing but must be fitted with a device that will give a volt free pulse output proportional to the flow rate, that can be either 1, 10 or 100 litres per pulse. Designed to monitor the flow of water entering the building or area, the unit raises an alarm and if required, shut of the water supply when the flow of water exceeds a preset maximum amount of allowable water for a present period of time, or by detecting a continuous flow of water. By setting realistic flows and time periods any increase above the user defined settings will be detected and dealt with by maintenance staff thereby saving water and limiting damage caused by a major leak.

## 2) Installation

**THIS EQUIPMENT SHOULD ONLY BE CONNECTED AND WORKED ON BY A QUALIFIED ELECTRICIAN.**

To mount the unit to a wall, first open the front door to expose the internal equipment. In the bottom and top corners of the housing is a fixing point. 3.5mm pozi-drive screws or any screw with a head no bigger than 7mm diameter can be used to fix the housing in place. Cable access into the box should be via cable glands which can be positioned anywhere around the enclosure or on the inside for back entry. Care should be taken not to damage the internal equipment when drilling the enclosure. A 230VAC power supply should be run from a fused spur to the unit's internal terminal block marked "L", "E" & "N". The fuse within the fused spur should be rated at 5 Amps. The BLDA1-2 unit should be linked to the pulsed water meters by a 0.8mm<sup>2</sup> conductor 2 core screened cable up to a maximum 400 meters away. Pulsed water meters usually have BSP thread connections up to 50mm, above 50mm PN16 flanged connections are used. If shutoff valves are required, they should be installed just after the water meter(s) and cabled in a flexible 3 core 230VAC cable rated at 3amps.

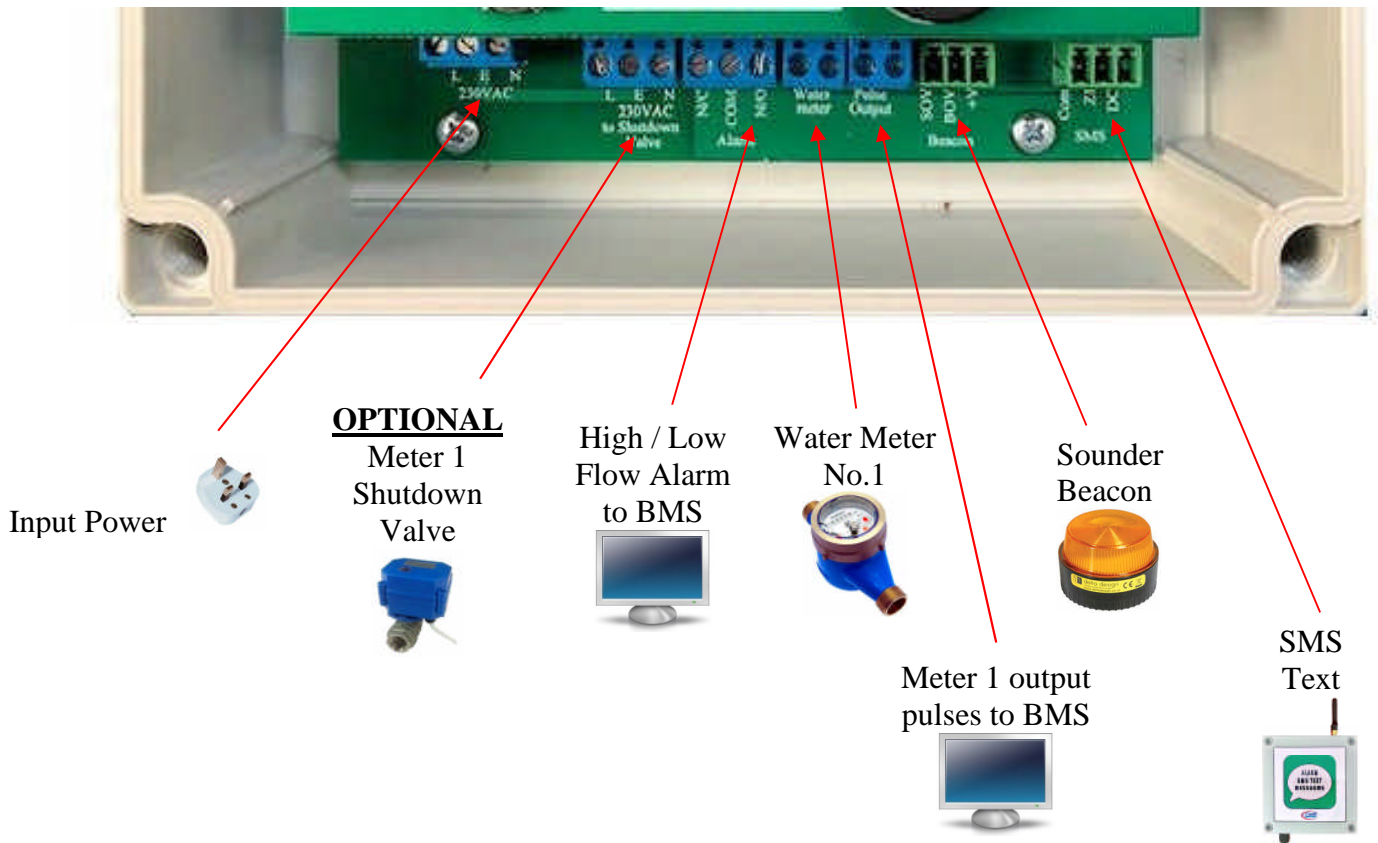

### 3) Wiring Detail

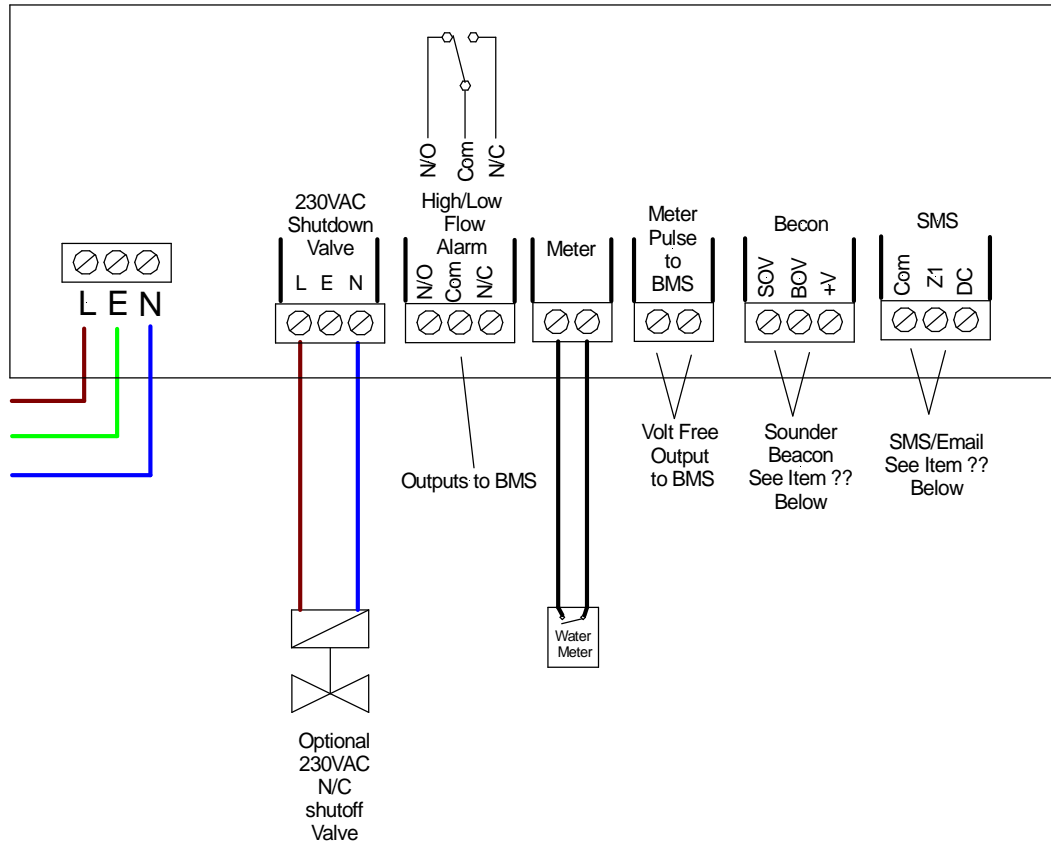

### 4) Water Solenoid Valves

If the system is supplied with water shutoff valves, once a water leak has been detected the unit will remove the 230V supply holding open the valve thereby closing it and stopping the flow of water

#### Connection of Water Shutdown Ball Valve



The 230VAC supply to the valves is generated from within the alarm unit. 15 to 25mm valves are supplied with a red and black cable whilst larger valves are red and green. For good practice connect live to the red wire and neutral to the black or green wire.

The Valve is supplied with a short length of cable that will need extending back to the valve terminals within the alarm unit.

**WARNING, in order to shut properly, this type of valve need powering for at least 3 minutes.**

## Connection of Water Shutdown Solenoid Valve



The 230VAC supply to the valves is generated from within the alarm unit.

Having removed and opened the 3-pin socket, connect live to terminal “1”, neutral to terminal “2” and Earth to the earth terminal

### **PLEASE NOTE;**

**We don't recommend that this type of valve and will NOT be supplied by CMR electrical. However, if this type of valve MUST be fitted, ensure that the arrow on its body facing the direction of flow, if not, the valve will not stop the flow of water.**

### **5) Relay outputs**

Volt free contacts have been provided for the following and can be found within the unit on the main PCB.

- a) High/Low Flow alarm, contacts rated at 30VDC 1A
- d) Meter output proportional pulses for onward indication

### ***6) Sounder Beacon and SMS Text messaging***

If a beacon or beacon sounder is supplied connect to the three terminals identified as “Beacon” as follows.

#### ***6-1) Non-Mutable Beacon or beacon sounder***

If the beacon or the beacon sounder is to be active (On all the time) until the water leak alarm has been cleared, connect as follows.

Terminal reference	Connect Beacon / beacon sounder terminals to the following terminals
+V	Beacon +V or Strobe /Tone + terminal
BOV	Beacon -V or Strobe /Tone - terminal
SOV	NO connection to this terminal

#### ***6-2) Mutable Beacon or beacon sounder***

If the beacon or the beacon sounder is to turn off when the “Mute” push button is pressed connect as follows.

Terminal reference	Connect Beacon / beacon sounder terminals to the following terminals
+V	Beacon +V or Strobe /Tone + terminal
BOV	NO connection to this terminal
SOV	Beacon -V or Strobe /Tone - terminal

**6-3) Mutable sounder Beacon on all the time**

If the beacon is to remain alight all the time an alarm is current but the sounder is to be turned off when the “Mute” push button is pressed connect as follows.

Terminal reference	Connect Beacon / beacon sounder terminals to the following terminals
+V	Strobe and Tone + terminal
BOV	Strobe - terminal
SOV	Tone - terminal

Warning; if the above option “6-3” is required, **remove** the electrical link connected between the second (Strobe -) & third terminals (Tone -) terminals within the sounder.

**6a) Fitting an SCA repeat alarm or SMS / Email messaging system**

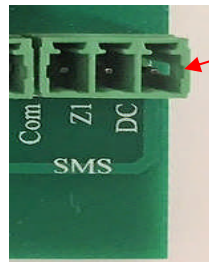

Use the “SMS” terminal block

SCA Terminal No.	SMS Terminal No.	Cable wire colours fitted to the messaging system
+V	DC	<b>RED</b>
Sig	Z1	<b>BLUE</b>
0V	COM	<b>BLACK</b>

**7) Push Button Description**

**External Buttons**

“Next Window”  
Used to display information outlined in item 8 below

“Mute” Use to silence the audible warning

“Water On”  
Used to reset the system after an alarm has been Muted and turn ON the water shutdown valve if fitted.



This button can also be used to place the unit into 4 hour “No Alarm Generated” period to allow tanks etc. to fill



## Internal Setup Buttons

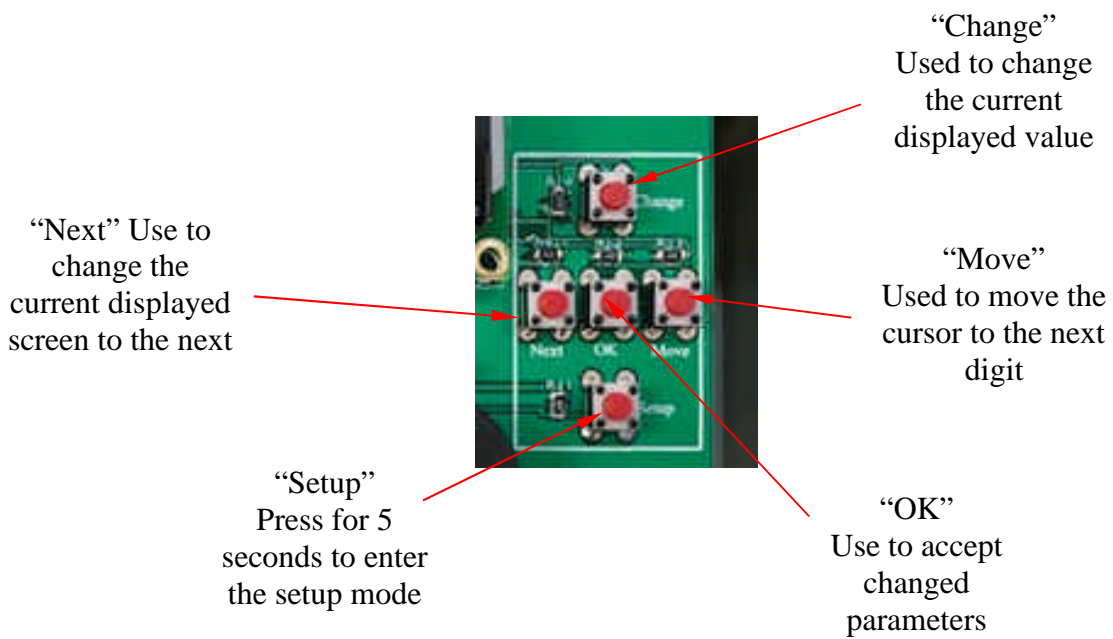

## 8) Display Screens

The unit will revert back to the first screen after two and a half minutes. Each press of the “Next Window” button will first show what the next window will be before displaying it. This is provided to allow quick motoring through the screens to the desired information.

Normal screen, if “next Window” button isn’t pressed, the unit will revert back to this screen after two and a half minutes.

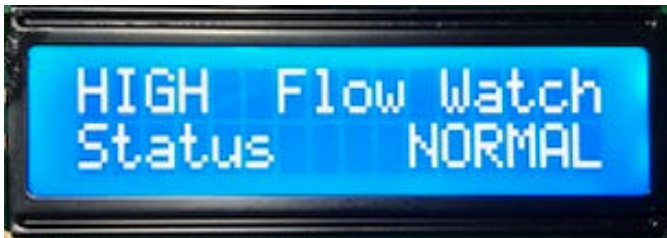

Current Flow Watch Type Low or High  
Alarm status “Normal” or “Alarm”

Press the “Next Window”. Button once, the following window will appear after 2 seconds.

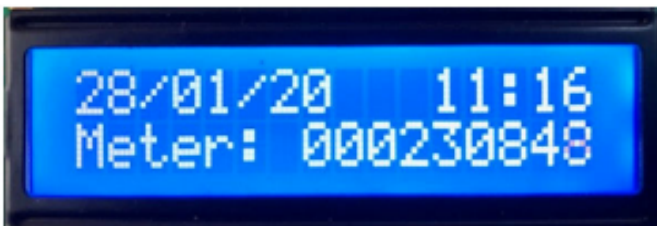

Day Date and Time  
Total Meter Reading

Press the “Next Window”. Button once, the following window will appear after 2 seconds.

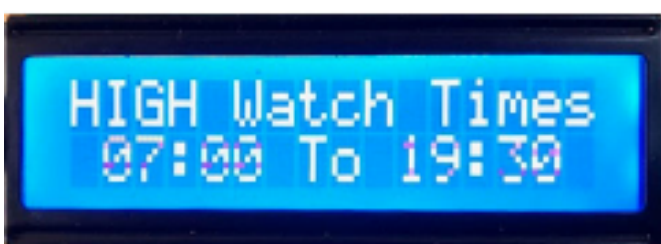

High Flow (occupied) time period

Press the “Next Window”. Button once, the following window will appear after 2 seconds.



Maximum and Minimum HIGH Flow Recorded readings

Press the “Next Window”. Button once, the following window will appear after 2 seconds.



Maximum and Minimum LOW Flow Recorded readings

Press the “Next Window”. Button once, the following window will appear after 2 seconds.



The system is set for a meter with a 1 pulse per Litre output

Press the “Next Window”. Button once, the following window will appear after 2 seconds.



High Flow ALARM limits, the total Number of Litres over what period of time. i.e., 350/L 00:10Hrs, if the unit sees 350 litres within 9 minutes the unit will go into alarm

Press the “Next Window”. Button once, the following window will appear after 2 seconds.

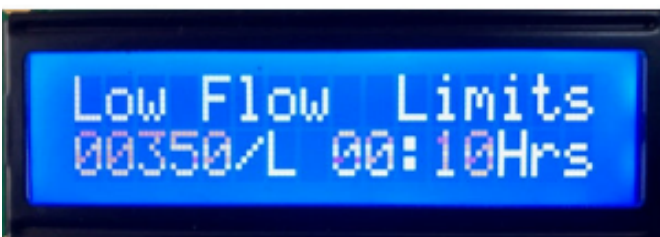

Low Flow ALARM limits, the total Number of Litres over what period of time. i.e., 350/L 00:10Hrs, if the unit sees 350 litres within 9 minutes the unit will go into alarm



## 9) Overview for setting up the system

### **IMPORTANT**

The Leak Detection System will not work correctly until it has been setup and commissioned as detailed below. You will need to nominate a person responsible for the operation and understanding of the system. This must include how to setup the system, keeping records and being aware what the alarms mean and their implications. Water consumption is unique for each installation; therefore, it is important to establish Low and High flow periods i.e. when the building is occupied or unoccupied. An initial investigation will be required to establish the weekly / daily patterns of water consumption. Further investigation should be undertaken at regular intervals to understand the overall usage including fluctuations such as filling water tanks.

Setting up the system will require;

- 1) Set or confirm the Pulse per Litre ratio for the fitted Meter
- 2) Set or confirm the approximate high and low water usage and timeout period
- 3) Confirm or set the Time and Date and day
- 4) Set or confirm the constant flow alarm timers
- 5) Set the High Flow times between Monday to Sunday this is the occupied (day time) period

### **Setup procedure 1**

If the setup parameters as detailed above are known, enter them using the following procedures. Once the system has been initially setup, let the system run for at least a week ignoring any generated alarms. At the end of this period, re-enter setups and adjust the maximum High & Low flow water volume and time periods based on the readings from the maximum Litres displayed on screen two and three.

### **Setup procedure 2**

If setup parameters are not known, enter setups and set both the high and low flow timers (see 11 below) to 00:00. This will stop the unit from alarming i.e. permanent sleep mode. Run for at least a week, at the end of this period, re-enter setups and adjust the maximum High & Low flow water volume and time periods based on the readings from the maximum Litres displayed on the screen (see 8 above).

***REMEMBER, YOU MUST ADD A TIME IN THE PERIOD TIMER TO TAKE THE SYSTEM OUT OF PERMINANT SLEEP MODE.***

### **How to enter the Setup Routine**

Press the “setup” push button, the internal sounder will rapidly pulse. This is to help stop persons from inadvertently altering the setup parameters. You MUST keep the “Setup” button pressed ignoring the pulsing horn until the display changes to the meter pulse rate screen at which time the pulsing horn will stop.

***Please note;***

***YOU WILL ONLY HAVE 5 MINUTES TO CHANGE THE SETINGS BEFORE THE SYSTEM EXITS SETUPS WITHOUT SAVING ANY CHANGES.***

**Internal Setup Push Button**

**Function**

Next

Each press of this button will move to the next parameter setup screen without any changes to the current screen. To exit Setups Keep pressing this button until one of the screens in section 8 appears.

Change

With the cursor flashing over a parameter or digit, press this button to change the parameter or digit to the next value. If you make a mistake, keep pressing the button until the correct value is displayed.

Move

Use this button to move the cursor to the next digit in a parameter. If you keep pressing this button it will rotate the flashing cursor through all the digits back to the most significant digit.

OK

You MUST press this button to save any parameter changes. The cursor will then move to the next parameter or screen.

**10) Setting up the Meter Pulses per Litre**

**Note; If the “OK” button is not pressed the new setting will NOT be saved.**

**The system can be set to 1, 10 or 100 litres per pulse**



Set to 1, 10 or 100 Litres per pulse

**Actions required;**

- a) To move on to the High & Low flow screen below, without making any changes to the pulse rate press the “Next” button.
- b) Press the “OK” button to accept Meter’s litre per pulse or;
- c) Press the “Change” button, each press will change the litres per pulse to 001, or 010 or 100 then back to 001 on the next press. When the correct Meter pulse rate is displayed press the “OK” button to accept, this will save the change and move to the next screen.

**11) Setting up High and Low maximum allowable litres and time period**

**Note; If the “OK” button is not pressed the new setting will NOT be saved.**

**The maximum litres can be set to between 00000 and 99999 litres, the time setting can be set between 00:00 to 24:00 hours**



Set High and Low flow Alarm settings

**Actions required:**

- a) To move on to the Clock setup below, without making any changes to the High or Low Flow maximum litres or alarm timer press the “Next” button.
- b) Press the “OK” button to accept High Flow litres and move onto the High Flow alarm timer or;
- c) Press the “Change” button, each press will increment the most the significant digits between 0 and 9, press again to return back to 0. When the correct number is displayed press the “Move” to move to the next digit or the “OK” button to save the new setting and move on to the High Flow timeout period timer. By repeated presses of the “Move” button, the cursor will rotate through the number back to the most significant digit of the number.
- d) With the cursor flashing on the most significant hours digit, repeat steps a, b and c above until the required time is displayed and press “OK” to save and move on to the Low Flow maximum litres.
- e) With the cursor flashing on the most significant Low Flow maximum litres digit, repeat steps a, b, c and d above.
- f) When finished press the “OK” button to accept the changes and move to the next screen.

**12) Setup the Clock**

**NOTE; The time format only allows for a maximum 23.59 hours and NOT 24:00  
If the “OK” button is not pressed the new setting will NOT be saved.**



Day, Month, Year and 24-hour time

Day of the week

You will only be allowed to enter a valid day, date and times. If you try to exceed the normal clock format the display will automatically display the minimum for that parameter i.e. if the display shows the time as 23:00 with the cursor flashing over the “2”, one more press on the “Change” button will result in the display showing 20:00. The clock has automatic leap year and UK summer time compensation.

***SYSTEM OPERATION IS DEPENDANT UPON THE CLOCKS DAY, DATE, TIME AND DAY OF THE WEEK BEING SET CORRECTLY.***

**Actions required:**

- a) To move on to the high flow time screen below, without making any changes to the clock press the “Next” button.
- b) Press the “OK” button to accept the displayed Day, Month, Year, Time and move to the day of the week setting.
- c) Press the “Change” button, each press will change the digits between 0 and its maximum and back to 0 again. When the correct number is displayed press the “Move” to move to the next digit or the “OK” button to save the new setting and move on to the Day of the week setting. By repeated presses of the “Move” button, the cursor will rotate through all of the day, month, year and time digits until its back to the most significant day digit. If a mistake is made, keep pressing the “Move” button until over the required digit. Press “OK” to save.
- d) With the cursor flashing on the day of the week, press the “Change” button until the correct day is displayed. Once correct, press the “OK” button to move to the next setup screen.

### 13) Set the continuous flow alarm time periods

**Note; If the “OK” button is not pressed the new setting will NOT be saved. Both timers can be set to a maximum of 59**

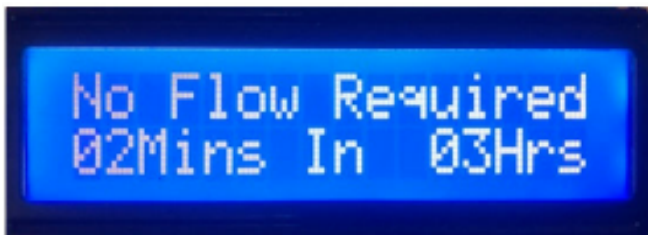

No flow time for a period of time in hours

The system looks for a period measured in minuets, of NO water flow, over a period measured in hours. If no water flow is detected for the first period (minuets) of time, the second period (hours) is reset and no alarm is generated. However, if there is a no, no flow period (minuets) i.e. continuous flow, within the second time period (hours), an alarm will be raised. The screen above shows that there MUST be a break in water flow for at least 2 minuets within a 3-hour period.

#### Actions required;

- To move on to the High Flow screen, without making any changes press the “Next” button.
- Press the “OK” button to accept and save the displayed Mins time and move to the Hrs time or;
- Press the “Change” button, each press will change the digits between 0 and its maximum and back to 0 again. When the correct number is displayed press the “Move” to move to the next digit or the “OK” button to save the new minutes time and move on to the hours’ time. By repeated presses of the “Move” button, the cursor will rotate through the digits until its back to the most significant digit. If a mistake is made, keep pressing the “Move” button until over the required digit again.
- Repeat steps a and c above to adjust the hours’ time.
- Press the “OK” button to save and move onto Monday’s high flow times.

### 14) Set the High Flow time periods for the day of the week

**Note; If the “OK” button is not pressed the new setting will NOT be saved. The time setting can be set between 00:00 to 24:00 hours**

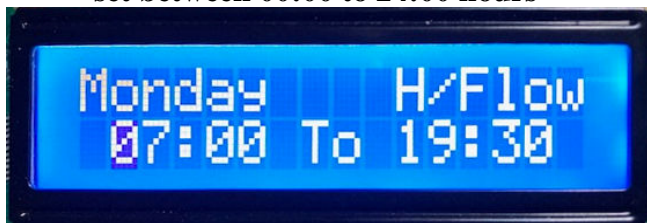

High Flow period

You will need to set the high flow period for each day of the week starting at Monday. This time period would normally be when the building is occupied i.e. an office block could be 07:00 to 18:30. Monday to Friday, 07:00 to 12:00 Saturday and unoccupied on Sunday.

#### Actions required;

- To move on to the next High Flow screen, without making any changes press the “Next” button.
- Press the “OK” button to accept and save the displayed start time and move to the end time or;
- Press the “Change” button, each press will change the digits between 0 and its maximum and back to 0 again. When the correct number is displayed press the “Move” to move to the next digit or the “OK” button to save the new start time and move on to the end time. By repeated presses of the “Move” button, the cursor will rotate through both hour digits until its back to the most significant digit. If a mistake is made, keep pressing the “Move” button until over the required digit again.
- Repeat steps a and c above to adjust the stop time.
- Press the “OK” button to save and move onto Tuesday’s high flow times.

With the next High Low Times screen on display, repeat steps a) through e) for all the days of the week. You MUST press “OK” or “Next” after setting up Sundays High Flow period to finish setting up the system and displaying the main screen.

### 15) How to reset the unit after an alarm

Once the unit detects an unusual flow of water it will setup an alarm by flashing the display, sounding the internal sounder, start the external sounder beacon if fitted, operate the BMS alarm contact, operate the Text messaging unit if fitted and turn off the water if a shutdown valve is fitted. When this happens, press the “Mute” button to stop all sounders and investigate the cause of the excessive water flow. Once you are happy that no leak exists, press the “Water On” button to reset the unit back to normal running.

### 16) Place the unit into a 4-hour SLEEP mode

If a large volume of water is required say to fill a water tank, the system can be placed into a 4-hour sleep period where it will ignore all water flow. This feature will only work if there are no current alarms, with the display status showing as NORMAL. To place the unit into Sleep Mode, press and keep pressing the “Water On” push button until the beeping stops and the display changes to.



The unit will remain in this mode with the minutes ticking down until the time period is up when it will revert back to normal mode. This feature can be cancelled at anytime by pressing the “Mute” push button.

### 17) Water meters

#### **MJ-SDC**

Multi-jet water meter with dry dial



The **WRAS MJ-SDC** is a multi-jet mechanical water meter with dry type dial counter suitable for a variety of wetting applications including general domestic, tenant fitting and commercial/industrial buildings (see EN14154 & EN15194).

#### **Key Features**

- Multi-jet water metering
- Compact design for most wetting applications
- Approved (EN14154 and EN15194) to BS 6841:2002
- Dry dial (non-wetting)
- Meter body materials meet water fitness
- Drinking water approved (WRAS)
- Galvalume base/Alloyed interface
- BSP fitting capabilities (1/2" & 3/4" sizes)
- Maximum pressure of 10bar
- Maximum temperature of 80°C (200°F)
- Pulse Output option (see EN14154 & EN15194)
- Temperature water tested and rated 50°C water

## Dimensions

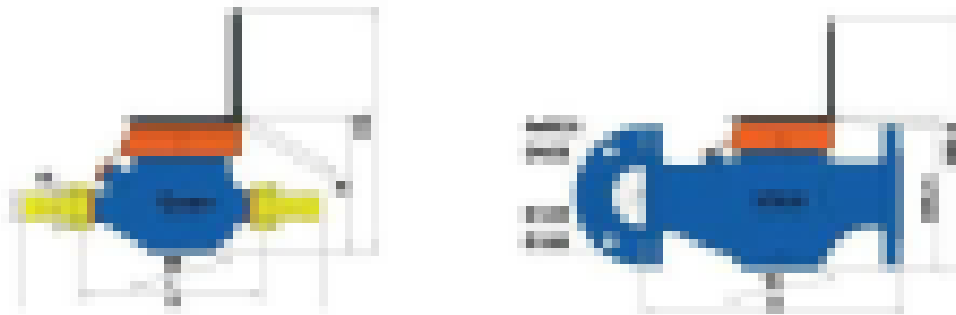

Size	DN15	DN20	DN25	DN32	DN40	DN50	DN65/80
L	100	110	120	130	140	150	160
H	100	110	120	130	140	150	160
H1	120/125	130	140/145	150/155	160	170/175	180/185
H2	100	110	120	130/135	140/145	150	160
H3	100	110	120	130	140	150	160
H4	100	110	120	130	140	150	160
H5	100	110	120	130	140	150	160
H6	100	110	120	130	140	150	160

L1, L2 are standard valve connection with general valve connection.

Additional length (optional available)

Size	DN15	DN20	DN25	DN32	DN40	DN50	DN65/80
L	100	110	120	130	140	150	160
	120		140	150	160		
	140		160				
	160						
	180						
	200						

## Technical Data

Size	DN15	DN20	DN25	DN32	DN40	DN50	DN65/80
W	DN15	DN15 for connection with DN15					
W1	DN15	DN15	0	DN15	DN15	DN15	DN15
W2	DN15	0	0	DN15	DN15	DN15	DN15
W3	DN15	DN15	DN15	DN15	DN15	DN15	DN15
W4	DN15	0	0	DN15	DN15	DN15	DN15
W5	DN15	DN15	DN15	DN15	DN15	DN15	DN15
W6	DN15	DN15	DN15	DN15	DN15	DN15	DN15
W7	DN15	DN15	DN15	DN15	DN15	DN15	DN15
W8	DN15	DN15	DN15	DN15	DN15	DN15	DN15
W9	DN15	DN15	DN15	DN15	DN15	DN15	DN15
W10	DN15	DN15	DN15	DN15	DN15	DN15	DN15
W11	DN15	DN15	DN15	DN15	DN15	DN15	DN15
W12	DN15	DN15	DN15	DN15	DN15	DN15	DN15
W13	DN15	DN15	DN15	DN15	DN15	DN15	DN15
W14	DN15	DN15	DN15	DN15	DN15	DN15	DN15
W15	DN15	DN15	DN15	DN15	DN15	DN15	DN15
W16	DN15	DN15	DN15	DN15	DN15	DN15	DN15
W17	DN15	DN15	DN15	DN15	DN15	DN15	DN15
W18	DN15	DN15	DN15	DN15	DN15	DN15	DN15
W19	DN15	DN15	DN15	DN15	DN15	DN15	DN15
W20	DN15	DN15	DN15	DN15	DN15	DN15	DN15
W21	DN15	DN15	DN15	DN15	DN15	DN15	DN15
W22	DN15	DN15	DN15	DN15	DN15	DN15	DN15
W23	DN15	DN15	DN15	DN15	DN15	DN15	DN15
W24	DN15	DN15	DN15	DN15	DN15	DN15	DN15
W25	DN15	DN15	DN15	DN15	DN15	DN15	DN15
W26	DN15	DN15	DN15	DN15	DN15	DN15	DN15
W27	DN15	DN15	DN15	DN15	DN15	DN15	DN15
W28	DN15	DN15	DN15	DN15	DN15	DN15	DN15
W29	DN15	DN15	DN15	DN15	DN15	DN15	DN15
W30	DN15	DN15	DN15	DN15	DN15	DN15	DN15
W31	DN15	DN15	DN15	DN15	DN15	DN15	DN15
W32	DN15	DN15	DN15	DN15	DN15	DN15	DN15
W33	DN15	DN15	DN15	DN15	DN15	DN15	DN15
W34	DN15	DN15	DN15	DN15	DN15	DN15	DN15
W35	DN15	DN15	DN15	DN15	DN15	DN15	DN15
W36	DN15	DN15	DN15	DN15	DN15	DN15	DN15
W37	DN15	DN15	DN15	DN15	DN15	DN15	DN15
W38	DN15	DN15	DN15	DN15	DN15	DN15	DN15
W39	DN15	DN15	DN15	DN15	DN15	DN15	DN15
W40	DN15	DN15	DN15	DN15	DN15	DN15	DN15
W41	DN15	DN15	DN15	DN15	DN15	DN15	DN15
W42	DN15	DN15	DN15	DN15	DN15	DN15	DN15
W43	DN15	DN15	DN15	DN15	DN15	DN15	DN15
W44	DN15	DN15	DN15	DN15	DN15	DN15	DN15
W45	DN15	DN15	DN15	DN15	DN15	DN15	DN15
W46	DN15	DN15	DN15	DN15	DN15	DN15	DN15
W47	DN15	DN15	DN15	DN15	DN15	DN15	DN15
W48	DN15	DN15	DN15	DN15	DN15	DN15	DN15
W49	DN15	DN15	DN15	DN15	DN15	DN15	DN15
W50	DN15	DN15	DN15	DN15	DN15	DN15	DN15
W51	DN15	DN15	DN15	DN15	DN15	DN15	DN15
W52	DN15	DN15	DN15	DN15	DN15	DN15	DN15
W53	DN15	DN15	DN15	DN15	DN15	DN15	DN15
W54	DN15	DN15	DN15	DN15	DN15	DN15	DN15
W55	DN15	DN15	DN15	DN15	DN15	DN15	DN15
W56	DN15	DN15	DN15	DN15	DN15	DN15	DN15
W57	DN15	DN15	DN15	DN15	DN15	DN15	DN15
W58	DN15	DN15	DN15	DN15	DN15	DN15	DN15
W59	DN15	DN15	DN15	DN15	DN15	DN15	DN15
W60	DN15	DN15	DN15	DN15	DN15	DN15	DN15
W61	DN15	DN15	DN15	DN15	DN15	DN15	DN15
W62	DN15	DN15	DN15	DN15	DN15	DN15	DN15
W63	DN15	DN15	DN15	DN15	DN15	DN15	DN15
W64	DN15	DN15	DN15	DN15	DN15	DN15	DN15
W65	DN15	DN15	DN15	DN15	DN15	DN15	DN15
W66	DN15	DN15	DN15	DN15	DN15	DN15	DN15
W67	DN15	DN15	DN15	DN15	DN15	DN15	DN15
W68	DN15	DN15	DN15	DN15	DN15	DN15	DN15
W69	DN15	DN15	DN15	DN15	DN15	DN15	DN15
W70	DN15	DN15	DN15	DN15	DN15	DN15	DN15
W71	DN15	DN15	DN15	DN15	DN15	DN15	DN15
W72	DN15	DN15	DN15	DN15	DN15	DN15	DN15
W73	DN15	DN15	DN15	DN15	DN15	DN15	DN15
W74	DN15	DN15	DN15	DN15	DN15	DN15	DN15
W75	DN15	DN15	DN15	DN15	DN15	DN15	DN15
W76	DN15	DN15	DN15	DN15	DN15	DN15	DN15
W77	DN15	DN15	DN15	DN15	DN15	DN15	DN15
W78	DN15	DN15	DN15	DN15	DN15	DN15	DN15
W79	DN15	DN15	DN15	DN15	DN15	DN15	DN15
W80	DN15	DN15	DN15	DN15	DN15	DN15	DN15
W81	DN15	DN15	DN15	DN15	DN15	DN15	DN15
W82	DN15	DN15	DN15	DN15	DN15	DN15	DN15
W83	DN15	DN15	DN15	DN15	DN15	DN15	DN15
W84	DN15	DN15	DN15	DN15	DN15	DN15	DN15
W85	DN15	DN15	DN15	DN15	DN15	DN15	DN15
W86	DN15	DN15	DN15	DN15	DN15	DN15	DN15
W87	DN15	DN15	DN15	DN15	DN15	DN15	DN15
W88	DN15	DN15	DN15	DN15	DN15	DN15	DN15
W89	DN15	DN15	DN15	DN15	DN15	DN15	DN15
W90	DN15	DN15	DN15	DN15	DN15	DN15	DN15
W91	DN15	DN15	DN15	DN15	DN15	DN15	DN15
W92	DN15	DN15	DN15	DN15	DN15	DN15	DN15
W93	DN15	DN15	DN15	DN15	DN15	DN15	DN15
W94	DN15	DN15	DN15	DN15	DN15	DN15	DN15
W95	DN15	DN15	DN15	DN15	DN15	DN15	DN15
W96	DN15	DN15	DN15	DN15	DN15	DN15	DN15
W97	DN15	DN15	DN15	DN15	DN15	DN15	DN15
W98	DN15	DN15	DN15	DN15	DN15	DN15	DN15
W99	DN15	DN15	DN15	DN15	DN15	DN15	DN15
W100	DN15	DN15	DN15	DN15	DN15	DN15	DN15





## **18) Water meter Installation**

Before installing the water meter, make sure that the meter has been chosen correctly. Check that the nominal diameter, flow rate, working temperature and pressure are compatible with actual installation conditions.

1. It is recommended that a straight length of pipe the same diameter as the meter and equivalent in length to 10 times the meter diameter is fitted immediately prior to the meter inlet and 5 times the meter diameter after the meter.
2. Before installing the meter make sure that the two sections of cut pipe are positioned correctly and supported where necessary, clean them carefully (especially if the pipes are empty) and allow water to flow for some time using a section of pipe instead of the meter, to remove any scale/debris leftover from the disturbance to the pipe.
3. Install the meter in a place protected from frost if possible (insulate with lagging materials during the winter months) and locate in the lowest part of the pipe work in order to avoid accumulation of air within the measuring chamber.
4. Install the meter in a position where it can be easily read, but is not accessible for tampering. Locate the meter where it will be safe from disturbance and damage from passing objects.
5. Install the meter so that the water is flowing in the same direction as the arrow shown on the body and in the position recommended by the manufacturer, following any indications on the dial. For guaranteed performance according to ISO 4064, meters should be installed in a perfectly horizontal plain. Accuracy may be reduced if installed in a vertical orientation.
6. It is advisable to install isolation valves upstream and down stream of the meter, in order to make the maintenance or verification of the meter possible. The installation of an internal or external non-return valve is also recommended.
7. There should be no restriction of the pipe at the meter inlet, and flange joints where used, should not obstruct the flow of water into the meter body. Any regulation of the flow should be carried out on the outlet side of the meter.

### **IMPORTANT:**

Before putting in to operation, it is necessary to purge the pipe and meter of air (for this operation it may be necessary to rotate the meter) Valves must be opened slowly so as not to allow any air present within the pipe work to damage the meter by over running it's internal measuring mechanism.