

Total Solutions Provider for Adhesive Dispensing Systems for the  
**AUTOMOTIVE INDUSTRY**



Adhesive Dispensing & Quality Assurance Systems

## ASSEMBLY

Headliner assembly in the automotive industry consists of bonding all types of components and materials, including retainers, clips, electrical and fluid harnesses, lighting and AC consoles to the underside of the automobile roof. The wide range of materials that need bonding requires a number of different hot melt formulations including PO hot melts, PUR and POR reactive hot melts.

Valco Melton manufactures all of the equipment and components required to provide a full hot melt dispensing solution for all types of hot melts used in this process; from manual to robotic applications. We provide advanced dispensing technology to traditional assembly configurations, adding closed-loop feedback for pressure and flow control. Add on/grammage rate reporting and data storage (per cycle or per assembled piece) can be communicated to the main machine PLC for analysis/quality assurance purposes.

Another specific application is headliner edgewrapping for sunroof models in which edges are folded and bonded to achieve a higher end finish. This process requires PUR reactive hot melt to be sprayed. Valco Melton offers its FlexSpray™ application gun series with Zero Cavity swirl spray technology modules for a clean, stable and consistent 'swirl spray' pattern. ADD: Our BAT Alpha(TM) Technology offers excellent edge definition, coverage with random fiber and continuous filament type spray patterns.

**Applications Include:**  
Headliners - Sunroof - Headlamps & Lighting - Seat Assembly

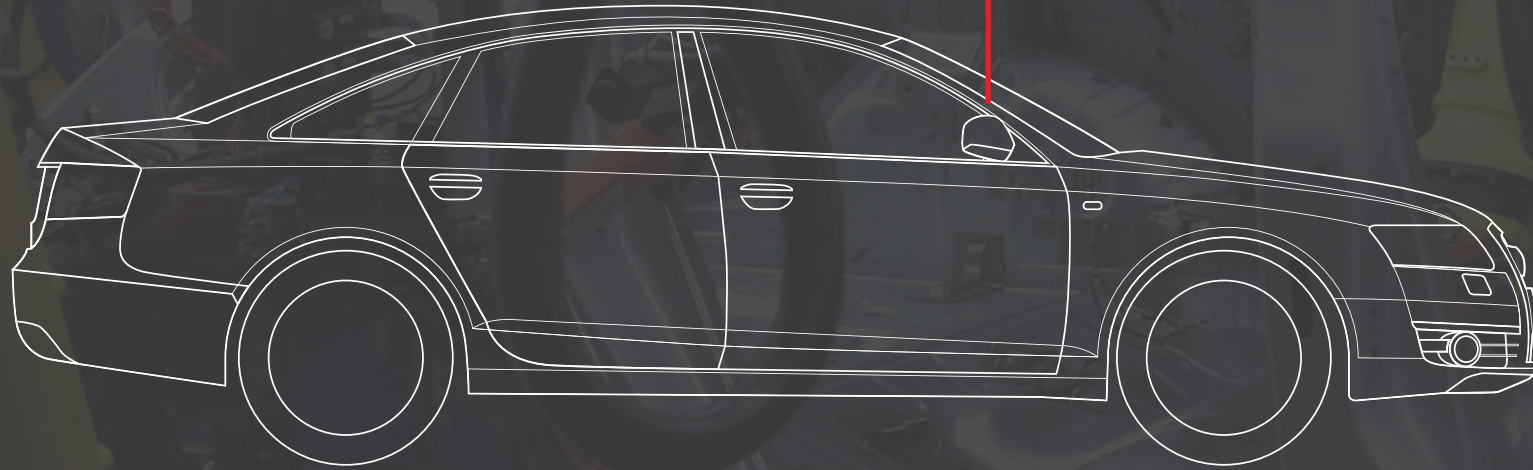

## INTERIOR DECORATIVE TRIM

Driver and passenger comfort and a focus on quality finishes inside a vehicle has lead to new materials and substrates in cockpits, armrests, dashboards, door interiors, inner pillars, etc. this large variety of materials and substrates, including TPOs, PVCs, real and synthetic leathers, ABS, and PP, etc with foam backings, are used today to improve the comfort and appearance of interiors.

Valco Melton provides hot melt application solutions for pre-trimmed materials that require individual piece coating. This includes roll-coaters for full coverage, with semi or fully automated piece/product/substrate loading and unloading loading and unloading, and spray technology which can be fully automated with robotics to achieve full coverage with accurate edge definition.

**Applications Include:**  
Load/Cargo Space Covers - Sound Deadening - Glove Boxes -  
Door Panels/Arm Rests - Floor Mat/Carpet - Package Tray

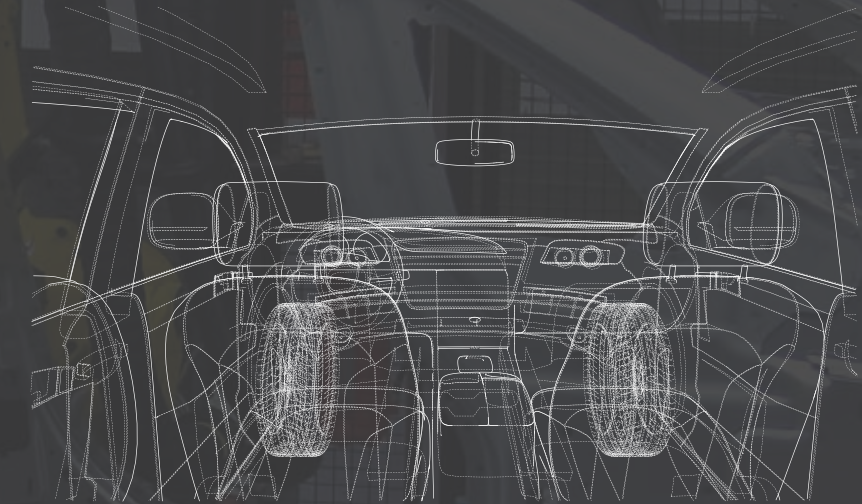

## OTHER COMPONENTS

Valco Melton provides a variety of other applications within the automotive industry. With our vast product line and industry knowledge, we can create a custom solution for the applications below.

**Applications Include:**  
Batteries - Filters - Windshield Wipers - Windshields/Glass -  
Emblems - Exterior Trim - Electronics - Gasketing

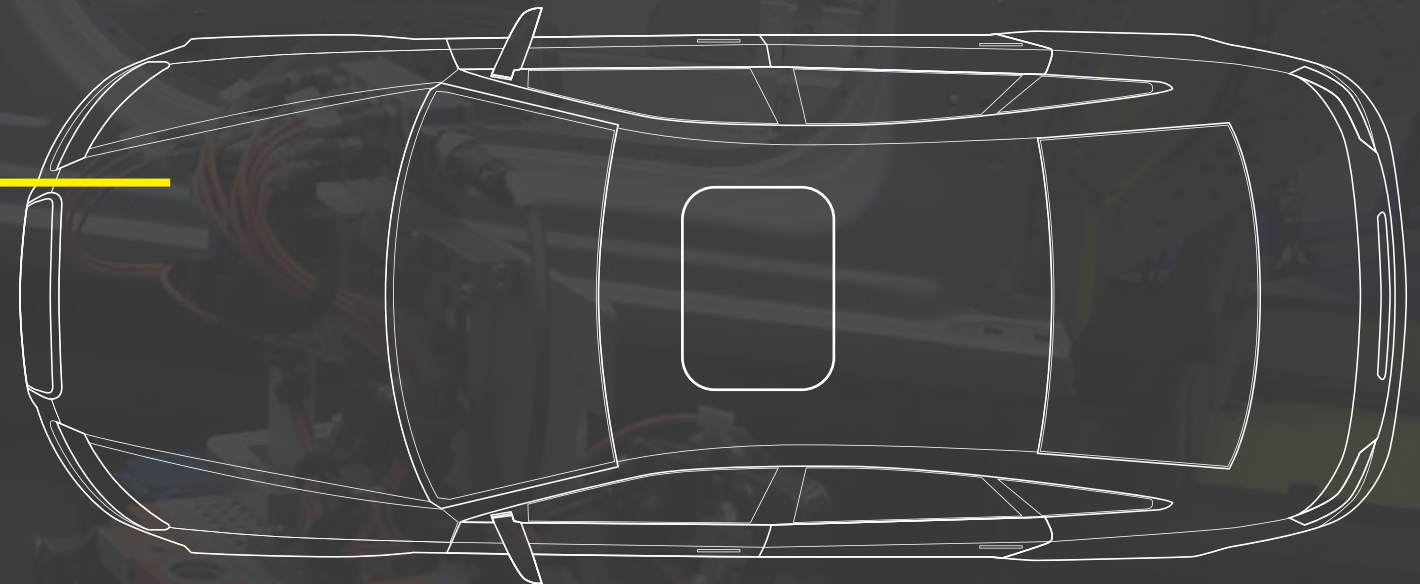



## APPLICATION SOLUTIONS FOR THE AUTOMOTIVE INDUSTRY

The automotive industry relies more and more on the use of various types of hot melt adhesives for a variety of technical solutions for bonding components and materials.

Valco Melton supports its customers in the automotive industry with years of experience and research resulting in a wide range of application technologies.

From basic hot melt systems for manual applications to turnkey projects for complete coating stations, Valco Melton provides precision adhesive and quality assurance solutions that improve customers' processes and products supplied to automotive manufacturing.



## VALCO MELTON AUTOMOTIVE DISPENSING EQUIPMENT COMPONENTS

### EXTRUDER

---

#### MEX Extruder

Valco Melton's MEX Series extruders achieve the highest melting rates when working with adhesives delivered in granulate format, such as EVA, PO, PA, or polyester, and provides a constant, homogeneous adhesive flow. Melt on demand technology preserves adhesive properties, preventing degradation, while extrusion technology eliminates the need for cleaning when switching between adhesive types.

#### Key highlights of the MEX Series include:

- Precise temperature control
- Minimize cleaning and maintenance downtime
- End unwanted production stoppages related to refiling with an integrated autofeed system
- Eliminate adhesive degradation with this closed, melt on demand system



### UNLOADERS

---

#### Pail & Drum Unloaders

Valco Melton pail and drum unloaders are designed for precision dispensing of a wide variety of heated adhesive and sealant materials. Configurable with a number of pumping and power configurations, the pail and drum unloaders feature a versatile design for continuous operation in a variety of manufacturing environments. Melt rates will vary with adhesive and platen selection. Three platens are available: flat, radial and high melt rate.

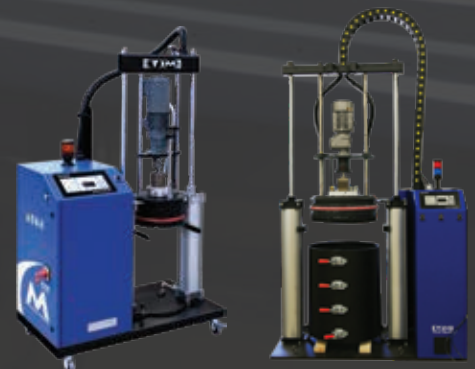

# MELT UNITS

## 4, 10, 16L EcoStitch Hot Melt Units

Valco Melton's EcoStitch 4, 10 and 16 series units are ideal for automotive applications, packaging, graphic/print finishing, product assembly, labeling and various paper converting applications. All EcoStitch Series units feature an LED display, spur gear pump with fixed or variable speed, "key-to-line" control, and a multi-functional control system. Other options include an integrated glue pattern control, line speed pressure control and integrated auto-feed systems.



## D48, D90, D180 Gear Pump Hot Melt Units

Valco Melton's D Series hot melt units are available in tank capacities of 48, 90 and 180 L to adapt to the application requirements of a variety of industries including automotive, coating and laminating, and specialized product assembly. All units feature several relief valve options ranging from the simple single-stage, to more sophisticated pneumatic relief systems. For ease-of-use, a unified operator interface is featured across the entire range of D Series units.



## FlexMelt

### Adhesive Melters: 8, 14, 30, 50 and 100 liters

Valco Melton's FlexMelt™ Series includes a complete range of hot melt tanks designed for the most demanding applications. All FlexMelt Series Units feature an intuitive MFC (Multi-Function Controller) for fast and easy configuration changes. This totally integrated control provides 'key-to-line' capabilities from one single, user-friendly screen.



## SmartMelt

The New Generation of adhesive melters: 15, 30, 65 & 120L

Valco Melton's SmartMelt Series has been specifically designed for easy plug-n-play upgrades of additional heating zones, flow control, pumping stations, and more. This fully customizable unit permits an accurate control of the glue applied during machine ramp up and down.



## IsoMelt

Valco Melton's IsoMelt Series has been specifically designed to process reactive hot melts such as PUR. Fast and easy changes to EVA or APAO without adhesive degradation are no problem. The tank can accommodate 2 PUR 20 kg standard size slugs, so that IsoMelt units can work with up to 40 liters of adhesive and meet the high production requirements of the automotive, PVC, and aluminum industries.



## M Series - Large Capacity Melters

When large volumes of materials are required to be dispensed, Valco Melton's M Series line of melters fits those requirements. These melters are often used when high melting rates are needed for wax, paraffins, EVA, and PSA adhesives. Large surface area melting grids and collectors with cast-in heater elements ensure excellent heat control and ultimate reliability and a higher melting rate with lower energy consumption. With capacities ranging from 170kg up to 1,000 kg, there is an M Series unit that will fit your high volume needs.





## ADHESIVES & DISPENSING EQUIPMENT

Valco Melton's adhesive processing capabilities for the automotive industry include polyolefins, ethylene-vinyl acetate (EVA), polyurethane reactive (PUR), silane modified polyolefin (POR), pressure sensitive adhesive (PSA), polyamides, amorphous poly alpha olefin (APAO), polyvinyl acetate (PVA), and butyls.

**Polyolefins** are a hot melt adhesive that is typically used for interiors. They contribute to a higher chemical resistance to acids and have a good resistance to moisture.

**Ethylene-Vinyl Acetate (EVA)** adhesive is mainly used for low-performance bonding. It is one of the most used polymers because of its low cost. EVA's are used in less demanding product assembly applications.

**Polyurethane Reactive (PUR)** adhesives adhere a multitude of different surfaces. They show good flexibility at lower temperatures, because of their low glass transition temperature. Other benefits include, heat resistance, high strength, excellent adhesion, solvent resistant. PUR goes through a chemical crosslinking process that means high heat will not affect them. PUR applications include seats, carpets, foam-based materials, cable attachment, bonding door sill protectors, gear knobs, and emblems.

**Silane modified polyolefin (POR)** adhesives are often used in place of PUR adhesives when the bonding surfaces pose a challenge for PUR. For instance, polypropylene surfaces which is common in automotive assembly. POR hot melts are also much more environmentally friendly (do not contain isocyanates). POR applications include seats, carpets, foam-based materials, cable attachment, bonding door sill protectors, gear knobs, and emblems.

**Pressure Sensitive Adhesives (PSA)** provide an alternative to traditional fastening methods that reduce costs and improve assembly efficiency. Benefits of PSAs include immediate bonding of multiple substrates, are processed through off-the-shelf machinery, and offer light-weight bonding compared to traditional mechanical fasteners (fuel economy). Applications for PSA include sound deadening insulation, interior bonding, and adhesive tape manufacturing for holding cables together.

**Polyamides** offer a high performance in severe chemical environments. They bond different substrates such as metals, treated polyethylene, and polypropylene.

**Amorphous Poly Alpha Olefins (APAO)** can be used for battery assembly, bonding foam to foam, load floors, automotive filters, headliner component assembly, head lamp bonding, HVAC assembly, sound deadening insulation, and bi-laminate fabric on door and instrument panels. The benefits of APAOs in the automotive industry include moisture resistance, good UV stability, functionality over a wide range of temperatures, and excellent thermal stability.

**Polyvinyl Acetates (PVA)** is a water-based cold glue adhesive which is environmentally friendly and offers multiple uses for automotive interior bonding.

**Butyl** sealants are applied like many other hot melt adhesives. They are highly flexible and impermeable which makes them ideal for keeping the automotive interiors safe from the elements. Butyls are excellent at resisting heat and humidity and are used for vibration, windshield/window sealing, noise, door trim sealant, and sound damping applications.



## ROBOT/AUTOMATED DISPENSING SOLUTIONS

Valco Melton has years of experience integrating dispensing solutions onto XYZ tables and articulated robot arms. Whether you are applying a liquid gasket material onto an engine block or spraying hot melt PSA during the manufacturing of sun visors, Valco Melton's engineering team collaborates with robot integrators to design solutions for automotive work cells. Highly complex applications require a team approach to create innovative and productive assembly environments.

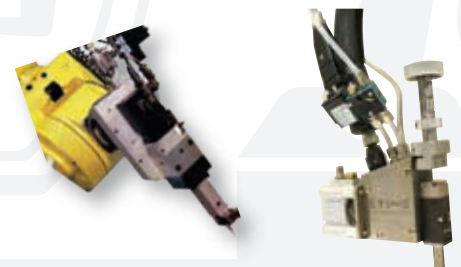
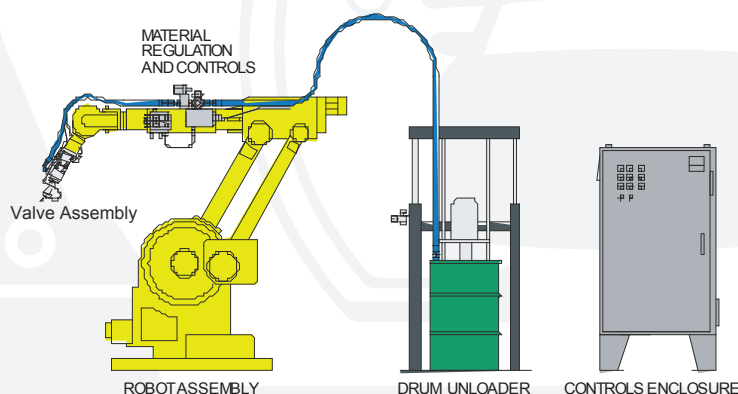
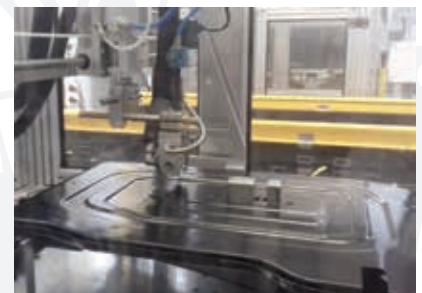

## SPRAY LAMINATION

For some material laminations, Valco Melton's hot melt spray systems can offer an alternative non-contact solution. Our hot melt BAT (Blown-Air-Technology) fiberization technology is in high demand along with traditional FlexSpray (Swirl Spray) technology. A wide array of adhesive patterns are available and optimal nozzle choices allow for success with lowest possible adhesive add-on's.

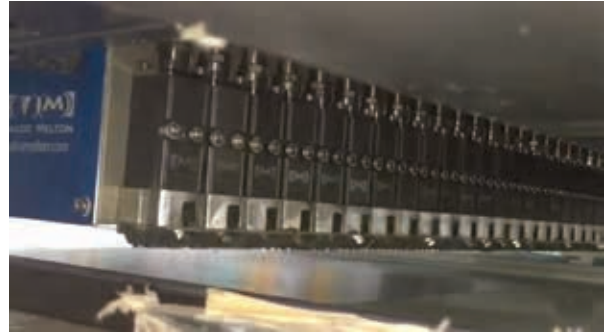

## COMPLETE COATING LINES

Substrates supplied in roll form can be processed on a complete coating line, where they can be coated, cooled, and rewound. Coated rolls can then be thermally reactivated, pressed and cut to the final product dimensions. AP Series Coating Lines are designed to coat and laminate multiple types of materials, in order to create laminated materials delivered in roll format, for a variety of industries and manufacturing processes. Every line is designed and configured for each customer's specific production requirements. Therefore, a wide variety of customization options are available from accessories like UV lamps or corona treaters to automation and connectivity elements.



## ROLL/ROLLER COATERS

Valco Melton's Roll/Roller Coaters have been engineered to apply conventional, thermoplastic or reactive adhesives to different kinds of substrates delivered in irregular, pre-cut or pre-shaped pieces. The modular design of our roll/roller coaters allows for the highest degree of customization, adapting to the specific production process requirements of each of our users and the industries they serve, from automotive components manufacturing to food and beverage packaging.

- Uniform and homogeneous coating, even when working with substrates with an uneven shape or surface and/or with constantly changing formats.
- Application widths from 300 to 1200mm.
- PLC Control with touch screen panel and Ethernet connection for remote access. Configurable access levels.
- Its modular design facilitates operator's access and parts disassembly for faster cleaning and maintenance tasks.

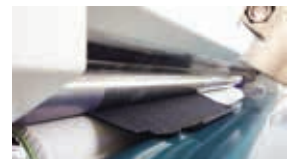

## HANDHELD APPLICATORS

Valco Melton offers Manual application with our compact, heavy duty and light weight user friendly handheld applicators, with a variety of bead, swirl and coating application finishes. Valco Melton offers a full range of pneumatic pump, fixed and variable speed pump hot melt tank melters that cover all production requirements.

Functional and ergonomic designs make our equipment easy and comfortable to use.



## World Headquarters

**USA, OH, Cincinnati** | Tel: +1.513.874.6550  
info@valcomelton.com

### America Manufacturing, Sales & Service Centers

**USA West Coast, CA, Petaluma**  
**GMS-Vansco**  
Tel: +1.707.285.3392  
inquiry@gmsvansco.com

**Mexico, México D.F**  
Tel: +52.55.6278.1727  
mexico@valcomelton.com

**Colombia, Bogotá**  
Tel: +57.313.421.0926  
colombia@valcomelton.com

**Brazil, Sao Paulo**  
Tel: +55.11.3071.2117  
brazil@valcomelton.com

### Europe Manufacturing, Sales & Service Centers

**Spain, Navarra, Orcoyen** | Tel: +34 948 321 580  
spain@valcomelton.com

**France, Valence** | Tel: +33 (0) 4 75 78 13 73  
france@valcomelton.com

**Italy, Brescia** | Tel: +39 030 2732544  
italy@valcomelton.com

**Italy, Brescia | ERO s.l.r** | Tel: +39 030 2731503  
info@ero-gluers.com

**Benelux, The Netherlands** | Tel: +31 252-673673  
benelux@valcomelton.com

**Hungary, Budapest** | Tel: +36 1-214-4705  
hungary@valcomelton.com

**UK, England, Telford** | Tel: +44 1952-677911  
uk@valcomelton.com

**Germany, Düsseldorf** | Tel: +49.211 984 798-0  
germany@valcomelton.com

**Poland, Dlugoleka** | Tel: +48 71 889 04 50  
poland@valcomelton.com



### South, Southeast, West & Central Asia Manufacturing, Sales & Service Centers

**Turkey, Istanbul** | Tel: +90 212 327 99 71  
turkey@valcomelton.com

**India, Bangalore** | Tel: +91.80.46553300  
india@valcomelton.com

**UAE, Sharjah** | Tel: +971.521305960  
uae@valcomelton.com

**Singapore, Singapore** | Tel: +65 850 95355  
singapore@valcomelton.com

### East Asia Sales & Service Centers

**China, Shanghai** | china@valcomelton.com  
**China, Xiamen** | Tel: +86.592.591.7854  
Fax: +86.592.591.7834 | china@valcomelton.com

To find the office nearest you, visit:  
<http://bit.ly/2Cb8Fv2>  
or snap a picture of this QR Code

