

constant  
powerservices

riello ups

MultiSentry

# General Catalogue







**Reliable power for a sustainable world**

**constant**  
**power** services

**Delivering total power solutions**

# Contents

<b>Key</b>	<b>4</b>
------------	----------

## **Company**

<i>Riello Elettronica and Riello UPS</i>	<b>6</b>
<i>Riello Elettronica and Constant Power Services Ltd</i>	<b>8</b>
<i>Constant Power Services Ltd</i>	<b>10</b>
<i>Riello UPS Brand values</i>	<b>12</b>
<i>Energy and sustainability</i>	<b>13</b>

## **Quick references**

<i>Guide to choosing a UPS</i>	<b>16</b>
<i>Options and accessories compatibility table</i>	<b>18</b>

## **Areas / Scope**

<i>SoHo Area</i>	<b>20</b>
<i>Data Centre Area</i>	<b>21</b>
<i>E-Medical Area</i>	<b>22</b>
<i>Industry Area</i>	<b>23</b>
<i>Transport Area</i>	<b>24</b>
<i>Emergency Area</i>	<b>25</b>

## **UPS Standard**

<i>iPlug</i>	<b>28</b>
<i>iDialog</i>	<b>32</b>
<i>iDialog Rack</i>	<b>34</b>
<i>Net Power</i>	<b>36</b>
<i>Vision</i>	<b>38</b>

<i>Vision Rack</i>	<b>42</b>
--------------------	-----------

<i>Vision Dual</i>	<b>46</b>
--------------------	-----------

<i>Sentinel Pro</i>	<b>50</b>
---------------------	-----------

<i>Sentinel Dual 1-3 kVA</i>	<b>54</b>
------------------------------	-----------

<i>Sentinel Dual 3.3-4, 6.5-10 kVA</i>	<b>58</b>
--	-----------

<i>Sentinel Dual 5-10 kVA</i>	<b>62</b>
-------------------------------	-----------

<i>Sentinel Power Green</i>	<b>66</b>
-----------------------------	-----------

<i>Sentinel Power</i>	<b>70</b>
-----------------------	-----------

<i>Multi Sentry</i>	<b>74</b>
---------------------	-----------

<i>NextEnergy</i>	<b>84</b>
-------------------	-----------

<i>Master MPS</i>	<b>88</b>
-------------------	-----------

<i>Master HP</i>	<b>96</b>
------------------	-----------

<i>Master HE</i>	<b>100</b>
------------------	------------

<i>Master Static Bypass</i>	<b>104</b>
-----------------------------	------------

<i>Master HP UL</i>	<b>108</b>
---------------------	------------

<i>Master Industrial</i>	<b>112</b>
--------------------------	------------

<i>Master FC400</i>	<b>114</b>
---------------------	------------

## **Modular UPS**

<i>Multi Power</i>	<b>118</b>
--------------------	------------

<i>Multi Guard Industrial</i>	<b>126</b>
-------------------------------	------------

## **CPSS**

<i>Central Supply Systems CSS</i>	<b>132</b>
-----------------------------------	------------



## Transfer Systems

<i>Multi Switch</i>	<b>136</b>
<i>Multi Switch ATS</i>	<b>138</b>
<i>Master Switch STS Single-phase</i>	<b>140</b>
<i>Master Switch STS Three-phase</i>	<b>142</b>

## Power solutions

<i>SuperCaps UPS</i>	<b>148</b>
<i>Master VDC</i>	<b>150</b>

## Software and accessories

<i>PowerShield<sup>3</sup></i>	<b>156</b>
<i>PowerNetGuard</i>	<b>157</b>
<i>NetMan 204</i>	<b>158</b>
<i>MultiCOM 302</i>	<b>159</b>
<i>MultiCOM 352</i>	<b>159</b>
<i>MultiCOM 372</i>	<b>159</b>
<i>MultiCOM 384</i>	<b>160</b>
<i>Multi I/O</i>	<b>160</b>
<i>I/O</i>	<b>160</b>
<i>Multi Panel</i>	<b>161</b>
<i>Multi Pass 10, 16 &amp; 16-R</i>	<b>162</b>
<i>MBB32A</i>	<b>162</b>
<i>MBB125A 4P, MBB100A 2P</i>	<b>162</b>

## Connectivity

<i>Point to point</i>	<b>166</b>
<i>Multipoint</i>	<b>167</b>
<i>UPS in parallel</i>	<b>167</b>
<i>Several systems in parallel and STS</i>	<b>168</b>
<i>Field bus over Ethernet</i>	<b>168</b>
<i>Modbus serial field bus</i>	<b>169</b>
<i>Virtualized systems</i>	<b>169</b>









## Technical pages

<i>Power problems</i>	<b>172</b>
<i>Types of UPS</i>	<b>173</b>
<i>Evaluation parameters</i>	<b>174</b>
<i>Main disturbances</i>	<b>175</b>
<i>Harmonics</i>	<b>176</b>
<i>UPS connected in parallel</i>	<b>177</b>
<i>Batteries</i>	<b>178</b>
<i>Current values</i>	<b>179</b>

## Services and contacts

<i>Services and Consultancy</i>	<b>182</b>
<i>Operating Offices</i>	<b>184</b>

# Key

<b>1:1</b>	Single-phase input and output		Tower
<b>1:3</b>	Single-phase input, three-phase output		Rack
<b>3:1</b>	Three-phase input, single-phase output		Rack / Tower
<b>3:3</b>	Three-phase input and output		Modular system
<b>1-3:1</b>	Single-phase or three-phase input, single-phase output		UPS suitable for home - small office applications
<b>1-3:3</b>	Single-phase or three-phase input, three-phase output		UPS suitable for datacentre applications
<b>VFD</b> TYPE	UPS VFD (Voltage Frequency Dependent)		UPS suitable for electro-medical applications
<b>VI</b> TYPE	UPS Line Interactive (Voltage Independent)		UPS suitable for industrial applications
<b>VFI</b> TYPE	UPS Online (Voltage Frequency Independent)		UPS suitable for transport applications (railways, airports, naval)
			UPS suitable for emergency applications



UPS with UL certificate



UPS with GS Nemko certificate



UPS ready for use in smart grids



Battery Swap. The batteries can be replaced during operation



UPS that can be combined with a flywheel



UPS also available with supercaps instead of batteries



Energy share sockets can be configured to disconnect load at user defined time (load shedding)



Plug and play. The UPS can be installed without the need for qualified personnel



Installation and initial start up should be carried out by qualified personnel



The device has a USB port



Airport/Shipyards



UPS classification Eco Level = 1



UPS classification Eco Level = 2



UPS classification Eco Level = 3



UPS classification Eco Level = 4



UPS classification Eco Level = 5



UPS classification Eco Level = 6



# Riello Elettronica and Riello UPS.

**We transform energy,  
continuously.**

**Riello Elettronica has been a solid point of reference on the industrial world stage for decades, gaining credibility as well as differentiating its presence in high technology markets. Riello UPS brand is now a world leader in the uninterruptible power supplies business.**

## **BUSINESS AREAS**

**A world without power is unthinkable. Everything moves and depends on energy. In our advanced society, any interruption in the supply of power, from a short sag or surge to a complete mains supply failure demonstrates just how fundamental energy is to our daily lives. If we are to maintain the delicate balance between man and nature, energy must also be managed, generated and delivered safely in a way that is as environmentally friendly as possible. Environmental considerations are now central to almost every project and investment decision, reflecting the very real need to change our thinking about energy generation and consumption.**

**POWER |** Our core business is energy conversion and the manufacture of Uninterruptible Power Supplies (UPS) devices that ensure power quality and business continuity, guaranteeing a power supply and the correct operation of systems even in the event a critical power failure. The Riello Elettronica Group is passionate about reducing energy consumption in order to contribute to the sustainable development of our planet. We aim to achieve this through a combination of environmentally friendly projects, investment and research into new technologies from clean and renewable sources and through the creation smart grid solutions.

**AUTOMATION |** The Group has a strong presence in command and control system sectors for domestic and industrial automation. We work with a passion for progress, with the utmost respect for laws and standards the environment. We draw up, develop, produce and distribute complete automation systems for access control.

**SAFETY & SECURITY |** We design and manufacture a complete range of solutions for intrusion, fire detection and domotics. Our products are designed to ensure optimum performance and the highest levels of employee safety and we utilise advanced technologies to create products that conform to international quality standards.

**REAL ESTATE |** The Group conducts its business activities through real estate property management and also through environmental protection activities with investment in agricultural holdings aimed at the enhancement and recover of the territory.

Continuous growth and successful figures; this is how Riello Elettronica continues its entrepreneurial tradition of innovation, meeting global challenges and the development of 'made in Italy' technology across international markets.

## BUSINESS UNITS

### POWER

**Riello UPS** A global leader in power continuity thanks to a comprehensive range of UPS (Uninterruptible Power Supplies).

**Aros Solar Technology** Photovoltaic Inverter (PV) and Energy Storage Systems to cover every need, from small domestic systems to solar power plants.

### AUTOMATION

**Cardin** A wide range of automation systems for access control.

**Ceimu** Hydraulic plants, lubrication and automation installations for a wide variety of industrial applications.

### SAFETY & SECURITY

**AVS Electronics** Systems for anti-intrusion, fire alarm and domotics.

**Gamma Systems** Products for the safety of workers in dangerous areas.

## POWER



**RIELLO UPS GmbH**



**RIELLO POWER SYSTEMS**



**RIELLO ONDULEURS**



**RIELLO ENERDATA**



**RIELLO TDL**



**RPS S.p.A.**



**RIELLO UPS Ltd**



**CONSTANT POWER SERVICES**



**RIELLO UPS ROMANIA**



**RIELLO DELTA POWER**



**RIELLO UPS AUSTRALIA**



**RIELLO POWER INDIA**



**RIELLO UPS ASIA**



**RIELLO UPS SINGAPORE**



**RPS AMERICA**



**RIELLO UPS MIDDLE EAST**

**RIELLO ELETTRONICA S.p.A.**



## AUTOMATION, SAFETY AND SECURITY



**CEIMU**



**GAMMA SYSTEM**



**AVS ELECTRONICS**



**ALARM INTERNATIONAL SYSTEM**



**CARDIN ELETTRONICA**



**CARDIN ELETTRONICA BELGIUM**



**CARDIN ELETTRONICA FRANCE**



**CARDIN ELETTRONICA DEUTSCHLAND**

**250**  
MILLION €  
TURNOVER

**1000**  
ABOUT  
EMPLOYEES

**85**  
BUSINESS  
COUNTRIES

**7**  
PRODUCTION  
SITES

Figures 2017

## HEADQUARTERS

Technology and innovation have always been the hallmarks of Riello Elettronica. They are the drivers behind our success – both globally and locally – and the outward expression of the entrepreneurial legacy that has its roots in Verona and surrounding areas. We are proud to maintain strong links with our local communities through our sponsorship and donation programmes which support local cultural, sporting and charitable activities and reflect the increasing social responsibility of the Group.







# Constant Power Services

**Any organisation that has invested in a UPS as part of its critical infrastructure understands how vital this equipment is to business operations.**

Having complete confidence in your UPS device also means having complete confidence in the team who install and maintain it.

Since Constant Power Services began trading in the late 1980s, customers have repeatedly trusted us to take care of the power protection infrastructure that supports their critical data. So much so that we have clients who have been with us for over 25 years.

**1988** Constant Power Services formed.

**1989-1990** During these years we acquired our own premises in Hitchin which virtually doubled the size.

**1995-1997** Investment in a new Italian manufacturing plant through R&D and shareholding saw the introduction of the Planet UPS.

**2003-2004** An exclusive agent now represents business interest in Scotland and we launch our new website.

**2005** Constant Power Services are increasingly becoming well known for their total power solutions, selling combined UPS, Generator and Switchgear.



**2006** Constant Power Services became an authorised subsidiary of Riello Elettronica and our product offering expanded rapidly.

**2008** With growth at a phenomenal rate CPS moved to new larger premises where warehouse space more than doubled again.

**2009-2011** ELCOS diesel generators became a part of our offering.

**2014** Saw the opening of our Letchworth Office with larger training and testing facilities.

**2015** International projects taken on including some in the Maldives and Australia.

**2016** In house Witness testing is now available.

**2017** The Multibox 252 a Containerised UPS solution is added to our range.



\*Riello UPS have been sponsors of Ducati since 2007 and now the FORMULA E and Audi Motor Sport.



# Specialist technical knowledge

**As part of the Riello Elettronica Group, we specialise in delivering and supporting the Riello UPS product range which is renowned across the world for its reliability, efficiency and competitiveness.**

Through our specialist technical knowledge, dedicated service delivery and our status as part of the Riello Elettronica Group, we have established our credibility as one of the most competitive and reliable turnkey UPS solutions providers in the UK. We are here to provide guidance, advice, support and give you the confidence that your UPS and critical infrastructure is safe in our hands.

Constant Power Services has worked extensively towards providing a total power solution having installed numerous generator and UPS

packages complete with associated switchboards for distribution and auto changeover facilities. Constant Power Services has also consolidated its position as a major UPS supplier to Hospital and Healthcare authorities.

Our unique OEM relationship means that, unlike other UPS solution providers, we only offer products that we know we can deliver and support throughout their entire lifecycle.

This in-depth technical knowledge of the Riello UPS product portfolio enables us to deliver a premium service which offers high first time fix

rates on maintenance contracts and guidance on product compatibility with any existing power protection equipment that is already in use.







# Services

## SOFTWARE AND ACCESSORIES

Constant Power Services are able to offer you a range of ethernet and Modbus interfaces including Environmental sensors and Riello Connect.

As a subsidiary of the Riello Elettronica Group, we are able to offer our customers Riello Connect, a remote monitoring service designed to increase resilience and reduce downtime of your mission critical equipment.

Riello Connect offers the invaluable peace of mind that comes from knowing the performance of your Riello UPS and battery systems are being continually monitored by our technical specialists.

## FACTORY WITNESS TESTING

With test facilities at our manufacturing plant in Italy and in our Head office in Letchworth we are able to test the UPS and demonstrate its functionality. A complete package including travel and accommodation can be tailored to your specific requirements. We are happy to discuss any additional tests you feel are required, prior to the dispatch and installation of the UPS on your site.

## BATTERY REPLACEMENTS AND UPGRADES

Replacement battery installations are based on "like for like" products or on a load-specific battery calculated to be more cost effective or space efficient – depending on your priorities.

We have close working relationships with several battery suppliers which means we are able to offer customers highly competitive prices on almost all battery blocks. Battery upgrades and replacements can be used in existing enclosures and racks or installed in new units.

## SITE SURVEYING

Constant Power Services are able to offer an inspection to advise on the suitability of an installation and to provide guidance in identifying if the UPS and the system are operating to their best capabilities.

This service is useful if you are considering increasing your UPS backup, or perhaps have taken over premises with a UPS in situ.

*“Whether they’re specifying a new system, training our staff or providing maintenance, we know from experience that they will go the extra mile and this is why we continue to work with them year after year.”*

Huw Llewellyn, Head of Property,  
Admiral Insurance





**Constant Power Services**  
**Service Technicians**  
 Sixteen Directly Employed



**Constant Power Services**  
**Stock Hubs**  
 Five Service Stock Hubs

**HEALTHCHECKS**

Constant Power Services provide a HealthCheck service for any Riello UPS product, to assess the UPS for inclusion on a maintenance agreement or simply to return it back to a fully operational condition.

You may not have purchased a maintenance agreement at the time of purchasing your UPS so a HealthCheck is a good option to check the installation and running of the UPS. If you then choose to have a Service Agreement after the HealthCheck, the visit is completely free.

**LOAD BANK TESTING**

Your business may require a complete system inspection, in which case Constant Power Services can offer site load testing to help identify potential areas for concern, whilst under controlled test conditions.

Our skilled technicians can identify quickly if the UPS is correctly connected and/or capable of supporting a critical load. We can also complete load bank testing as part of a factory witness test.

**PROJECT MANAGEMENT**

Our dedicated projects team look after the transition period from point of order to site handover. From equipment location, site access, specialist positioning as well as environmental limitations which we carefully plan to suit your project programme and your budget.

Our specialist team has in excess of 30 years, UPS project management experience, which we provide to our customers to ensure that all aspects are considered when purchasing a UPS.

**MAINS MONITORING (FLUKE METERING)**

Constant Power services are able to provide information on site conditions utilising their metering equipment. This service can be used to: look at specific circuits or equipment, investigate power issues or for monitoring load levels over a duration so that a more informed decision can be made about the size of UPS required.

**THERMAL IMAGING**

Thermal imaging highlights any anomalies, for example, if one battery is hotter or colder than the others it shows there is a potential problem.

Normally hot spots show a weak battery cell that may still be at the correct voltage, so would never normally be found. Imaging will highlight loose or poor connections, giving you an insight into the running of your system.



# Riello UPS

## Brand Values

### **Innovation - the secret of an all-Italian success story**

Riello UPS offers a vast range of products, organised into 22 ranges of uninterruptible power supplies (UPS)-based on several different state-of-the-art technological architectures. Thanks to its two research centres in Legnago (Verona) and Cormano (Milan), world class centres of excellence for the design, development and testing of uninterruptible power supplies, Riello UPS can constantly innovate its product portfolio, keeping it at the pinnacle of performance, reliability and competition. In addition, in the event of large tenders or commissions Riello UPS often provides bespoke solutions based on the specifications provided, demonstrating its attention to the customer's individual requirements.

Riello UPS designs and manufactures its UPS in Italy in order to maintain direct control over quality and reliability standards, and by closely following the entire manufacturing process, sales and after-sales service. This strategy allows for a process of continuous improvement, monitoring customer opinions and using them to make rapid adjustments to optimise features as required by the market.

This process of continuous improvement, as well as having a direct effect and benefit on sales and after-sales service, helps to further consolidate Riello UPS's image as a reliable, dynamic and quality-oriented company.

It doesn't stop here however: the solid results achieved by Riello UPS in the development of UPS solutions equipped with completely innovative and avant-garde technologies such as the Modular UPS and Smart Grid Ready UPS, i.e. ready for intelligent power distribution grids which represent the future of energy supply, are the best demonstration that innovation and quality really are the secrets of Riello UPS's success.

# Energy and sustainability

## Reliable power for a sustainable world

**“Reliable power for a sustainable world” - the Riello UPS philosophy condensed into a few simple words - a global brand constantly searching for the most innovative solutions**

Riello UPS manufactures efficient solutions that ensure power quality and business continuity, guaranteeing power supply and the correct operation of systems even in the event of critical situations.

Riello UPS is constantly implementing new solutions into its products that are aimed at reducing power consumption by increasing efficiency, and actively participating in the promotion of sustainable development. To this end the company also sets up environmental projects and makes large investments in the development of new technologies for harvesting clean and renewable energy sources. Riello UPS's social commitment aims to help the present as well as shape a bright future, combining the inevitable

need for energy with environmental protection.

The environmental management system employed by Riello UPS is ISO14001 certified.

Riello UPS has always been a strong supporter of the Code of Conduct on Energy Efficiency and Quality of AC Uninterruptible Power Systems, a document signed by the major European manufacturers of UPS addressed to the European Commission.

It sets out the energy efficiency targets for power ranges from 300 VA to >200 kVA, from 25% to 100% loads. Riello UPS was also the first European Manufacturer to identify its products in terms of ECO energy efficiency ratings.





## ECO ENERGY LEVELS

Riello UPS uninterruptible power supplies power some of the most critical data centres and servers in use today. Within these environments, energy management is critical. Running costs must be minimized without compromising



resilience, i.e. the ability to adapt to adverse external conditions whilst ensuring complete availability of the services provided. Equipment must operate at the highest possible levels of efficiency to reduce the strain on critical power supplies and minimise the effect on the installation area. Riello UPS models have always been compliant with the highest levels of efficiency in terms of energy protection and are classified according to a scale with 6 levels, corresponding with the

efficiency value of the UPS with respect to the European Code of Conduct; this is known as the Eco Energy Level.

The ECO Energy Level is a tool implemented by Riello UPS to help customers to identify the products with the highest levels of efficiency in terms of energy protection; the 6 levels have recently been updated to comply with the stringent new efficiency levels required by the CoC.

In addition to this, the availability of Smart Mode provides a further method for improving efficiency by furthering Eco Energy Levels assessment.

Riello UPS 's Eco Energy Level is more than just a concept; it is a system that demonstrates how the UPS that get the highest marks (levels 4, 5 and 6) are more efficient, and therefore more beneficial economically and environmentally.

The Eco Energy Level system demonstrates both how the most efficient UPS provide energy savings that allow the cost of their purchase to be recovered quickly with respect to standard efficiency UPS, as well as how their use leads to significant reductions in carbon emissions into the atmosphere.

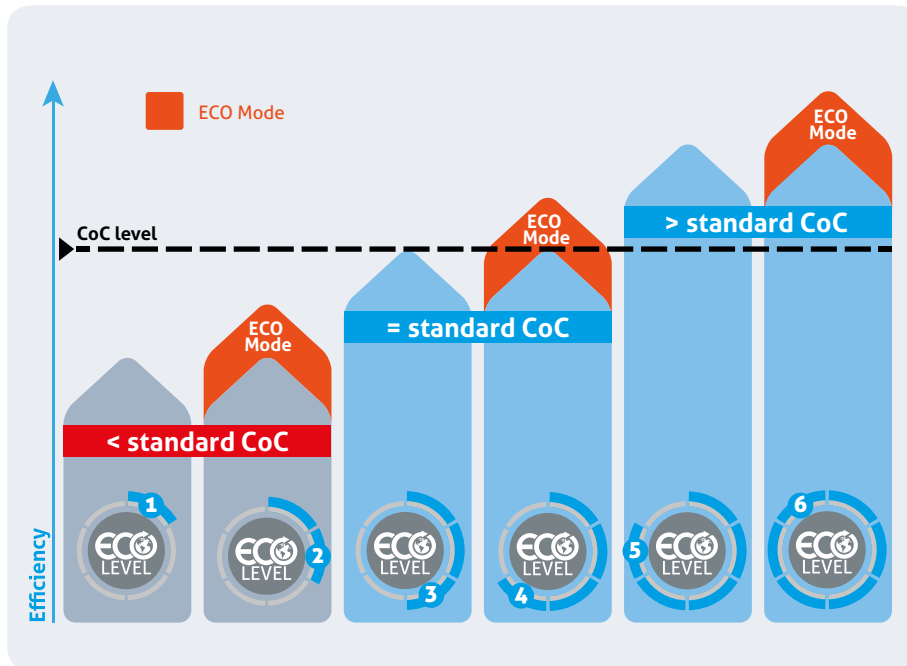

## THE HUMAN FACTOR, ADDED VALUE

The concepts of product quality and excellence are central to Riello UPS's corporate philosophy, but this is combined with a further concept: the value of people, whether they are customers, users or colleagues. At every staff level in Riello UPS, the sense of belonging to the company and respect for others has created an excellent working environment, which has been instrumental in achieving the great results enjoyed by Riello UPS. The team work that leads everyone to give their best every day, coordinating with colleagues to achieve the set

results is the result of the careful selection, management and training of staff and above all thanks to a healthy attitude of sharing targets at all levels and an ethical belief in added value. One of the secrets of Riello UPS's success as a company is the reciprocal respect for each person's contributions and the shared effort to ensure the best levels of service and highest levels of customer satisfaction. Proof of this are the awards that Riello UPS has received and continues to receive, the latest from Frost & Sullivan, who awarded Riello UPS with the "New Product Innovation Award 2015".



## UPS SMART GRID READY



The evolution of electrical power grids is a key element for achieving greater sustainability; particularly fundamental are the power management systems for balancing supply and demand, for using energy in the most sustainable and efficient way: Smart Grids.

Smart Grids are nothing more than power grids that efficiently integrate and manage the behaviour and actions of all the connected consumers (generators, output points, etc.), with the aim of ensuring the economically efficient operation of the electrical

system, with a high level of safety, continuity and quality of supply. Smart Grids not only introduce new concepts to power grids but also new business opportunities with regards to installations with UPS: batteries of uninterruptible power supplies represent significant investments, but they are only partially used. Using these distributed power accumulators and generating business in power accumulation scenarios will become fundamentally important. Smart Grids also mean the integration of different energy sources, two-way flow, information exchange grids and centralised management. In this new scenario installations with UPS can take on new roles, becoming virtual power plants, decentralised power accumulation systems, variable

power generators and above all they can be combined with renewable energy sources. In order to be "Smart Grid Ready", UPS must allow for the implementation of power accumulation solutions, and at the same time ensure extremely high levels of efficiency. They must also be able to independently select the most efficient operating method based on the status of the grid. They must be able to electronically interface with the energy manager using the Smart Grid communication network. Always open to technological innovation, Riello UPS has invested in research and technology to develop smart grid ready products, creating the NextEnergy, Multi Power, Master HE, Master HP, Master MPS and Multi Sentry ranges, the first Smart Grid Ready UPS on the market.

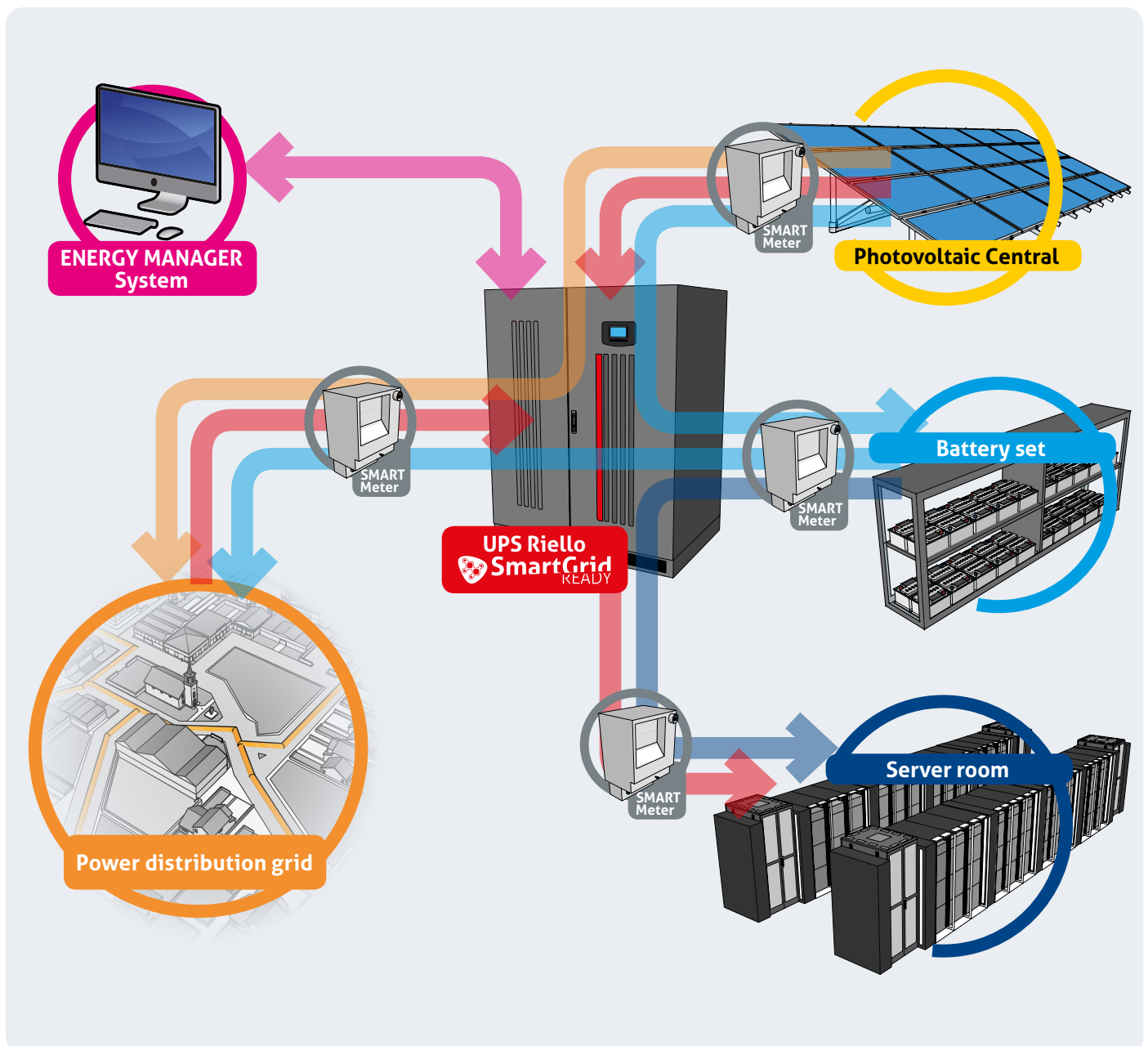

# Guide to choosing a UPS

Choose the main parameters required for your installation and discover which UPS in the Riello range can meet your needs. Further details are provided in the dedicated pages for each product.

## Parameters



	Type			Instal	Specifications											Connect				Areas						
	UPS VFD	UPS VI	UPS VFI		Tower / Rack / Modular	1 - 1	3 - 1	1/3 - 1	1/3 - 3	3 - 3	Manual bypass	Internal batteries	Parallelable	Transformerless	Transformer based	Embedded ethernet	USB	RS232	Dry contact	# Slot	EPO	Soho	DataCentre	e-Medical	Industry	Transport
iPLUG	●			T	●						●	●			●		-			●						
iDIALOG	●			T	●						●	●			●		-			●						
iDIALOG RACK	●			R	●						●	●			●	●	-		●	●						
NET POWER		●		T	●						●	●			●	Ⓞ	-			●						
VISION		●		T	●						●	●			●	●	opt 1			●						
VISION RACK		●		R	●						●	●			●	●	opt 1		●	●	●					
VISION DUAL		●		T R	●						●	●			●	●	opt 1		●	●	●					
SENTINEL PRO			●	T	●						●	●			●	●	opt 1		●		●	●			●	
SENTINEL DUAL 1-3 kVA			●	T R	●						●	●			●	●	opt 1		●	●	●	●	●	●	●	●
SENTINEL DUAL 3.3-4/6.5-10 kVA			●	T R	●	Ⓐ	Ⓑ				●	●			●	●	opt 1		●	●	●	●	●	●	●	●
SENTINEL DUAL SDU 5-10 kVA			●	T R	●						●	●	●		●	●	opt 1		●	●	●	●	●	●	●	●
SENTINEL POWER GREEN			●	T	●	Ⓒ	Ⓓ			●	●	●	●		●	●	opt 1		●	●	●	●	●	●	●	●
SENTINEL POWER			●	T	●	Ⓔ	Ⓕ			●	●	●	●		●	●	opt 1		●	●	●	●	●	●	●	●
MULTI SENTRY			●	T			Ⓖ		●	●	●	●	●		●	●	opt 2		●		●	●	●	●	●	●
NEXTENERGY			●	T					●	●	●	●	●		●		std 2		●		●	●	●	●	●	●
MASTER MPS			●	T			Ⓖ		●	●	●	●	●		●		std 2		●		●	●	●	●	●	●
MASTER HP			●	T					●	●	●	●	●		●		std 2		●		●	●	●	●	●	●
MASTER HE			●	T					●	●	●	●	●		●		std 2		●		●	●	●	●	●	●
MASTER HP UL			●	T					●	●	●	●	●		●		std 2		●		●	●	●	●	●	●
MASTER INDUSTRIAL			●	T			Ⓖ		●	●	●	●	●		●		std 2		●				●	●		
MASTER FC400			●	T					●		Ⓗ	●	●		●		std 2		●					●		
EMERGENCY solution CSS 1 h			●	T			●		●	●	●	●	●		●	●	opt 2		●				●		●	●
EMERGENCY solution CSS 3 h			●	T			Ⓖ		●	●	●	●	●		●		std 2		●				●		●	●
MULTI POWER			●	M					●	●	●	●	●	●		opt	opt 2		●		●			●		
MULTI GUARD INDUSTRIAL			●	M			●	●	●	●	●	●	●		●	●	opt 2		●		●	●	●	●	●	●
MASTER STATIC BYPASS	-	-	-	T						-	-	-	-	-		●	std 2			●						
MULTI SWITCH	-	-	-	R	●					-	-	-	-	-		●	- 1			●						
MULTI SWITCH ATS	-	-	-	R	●					-	-	-	-	-	●	●	std 1			●						
MASTER SWITCH STS 1ph	-	-	-	R	●					-	-	-	-	-	●	●	std 1			●						
MASTER SWITCH STS 3ph	-	-	-	T					●	-	-	-	-	-	●	●	std			●						



# Options and accessories compatibility table

Identify the UPS that supports the software and accessories your installation requires.

Parameters	Software		Accessories						
	POWERSHIELD <sup>3</sup> Shutdown software	POWERNETGUARD Inventory manager software	NETMAN 204 Card - Ethernet - SNMP v1,v3	MULTICOM 302 Card - Modbus/Jbus interface	MULTICOM 352 Card - Interface duplexler	MULTICOM 372 Card - RS232 interface	MULTICOM 384 Card - Relay I/O interface	MULTI I/O Box - Relay I/O Card & Modbus/Jbus interface	MULTIPANEL Remote Display interface
iPLUG	●								
iDIALOG	●								
iDIALOG RACK	●		Ⓟ	Ⓟ	Ⓟ				
NET POWER	●	ⓅⓅ	ⓅⓅ	ⓅⓅ	ⓅⓅ			Ⓟ	
VISION	●	●	●	●	●	●	●	●	●
VISION RACK	●	●	●	●	●	●	●	●	●
VISION DUAL	●	●	●	●	●	●	●	●	●
SENTINEL PRO	●	●	●	●	●	●	●	●	●
SENTINEL DUAL 1-3 kVA	●	●	●	●	●	●	●	●	●
SENTINEL DUAL 3.3-4/6.5-10 kVA	●	●	●	●	●	●	●	●	●
SENTINEL DUAL SDU 5-10 kVA	●	●	●	●	●	●	●	●	●
SENTINEL POWER GREEN	●	●	●	●	●	●	●	●	●
SENTINEL POWER	●	●	●	●	●	●	●	●	●
MULTI SENTRY	●	●	●	●	●	●	●	●	●
NEXTENERGY	●	●	●	●	●			●	●
MASTER MPS	●	●	●	●	●			●	●
MASTER HP	●	●	●	●	●			●	●
MASTER HE	●	●	●	●	●			●	●
MASTER HP UL	●	●	●	●	●			●	●
MASTER INDUSTRIAL	●	●	●	●	●			●	●
MASTER FC400	●	●	●	●	●			●	●
EMERGENCY solution CSS 1 h	●	●	●	●	●			●	●
EMERGENCY solution CSS 3 h	●	●	●	●	●			●	●
MULTI POWER	●	●	●	●	●	●	●	●	●*
MULTI GUARD INDUSTRIAL	●	●	●	●	●	●	●	●	●
MASTER STATIC BYPASS	●	●	Ⓟ	Ⓟ	Ⓟ			●	●
MULTI SWITCH	●	●	●						
MULTI SWITCH ATS	●		●	●	●				
MASTER SWITCH STS 1ph	●		●	●	●				
MASTER SWITCH STS 3ph	●		Ⓟ	Ⓟ	Ⓟ				



## Key

Ⓛ 1000 - 1500 - 2000 VA

Ⓝ up to 20 kVA 1:1

Ⓞ up to 60 kVA 3:3

Ⓟ In combination with communication card adapter

\* Compatibility needs the MultiCom 372 card in addition.



### Accessories

info

MANUAL BYPASS 16A MBB 16A	MAN. BYPASS 16A RACK MBBR 16A	AUTOM. BYPASS 16A MBB 16A	AUT. BYPASS 16A RACK MBBR 16A	MANUAL BYPASS 100A 2P	MANUAL BYPASS 125A 4P		ACRONYMS	UPS page
							iPLUG	IPG 26
							iDIALOG	IDG 30
							iDIALOG RACK	IDR 32
							NET POWER	NPW 34
							VISION	VST 36
							VISION RACK	VSR 40
●	●	●	●				VISION DUAL	VSD 44
●		●					SENTINEL PRO	SEP 48
●	●	●	●				SENTINEL DUAL 1-3 kVA	SDH 52
							SENTINEL DUAL 3.3-4/6.5-10 kVA	SDL 56
							SENTINEL DUAL 5-10 kVA	SDU 60
				●			SENTINEL POWER GREEN	SPM / SPH 64
				●			SENTINEL POWER	SPW / SPT 68
				Ⓝ	Ⓞ		MULTI SENTRY	MCM / MSM / MCT / MST 74
							NEXTENERGY	NXE 82
				Ⓝ	Ⓞ		MASTER MPS	MPM / MPT 86
							MASTER HP	MHT 94
							MASTER HE	MHE 98
							MASTER HP UL	MHT UL 106
							MASTER INDUSTRIAL	MIM 110
							MASTER FC400	MFC 112
							EMERGENCY solution CSS 1 h	C1T / C1M 130
							EMERGENCY solution CSS 3 h	C3T / C3M 130
							MULTI POWER	MPW 118
							MULTI GUARD INDUSTRIAL	GMI 126
							MASTER STATIC BYPASS	MSB 102
							MULTI SWITCH	MSW 134
							MULTI SWITCH ATS	MTA 136
							MASTER SWITCH STS 1ph	MMS 140
							MASTER SWITCH STS 3ph	MTS 142



Other specific options can be found on the dedicated product pages



## SoHo Area

## RECOMMENDED PRODUCTS

### iPlug



### Net Power



### Vision



### Vision Dual



### Sentinel Pro



### Sentinel Dual Low Power



## REFERENCES

### Italy

- Consip
- Carrefour
- Dico / Coop

### Sweden

- Ikea

### Germany

- Hilton Hotel
- Mc Donald's

### UAE

- Royal Intern.

### Portugal

- Intermarché

### France

- Carrefour

### Australia

- Toys "R" us
- Lonely Planet

### United Kingdom

- ASDA

## FEATURES

- Low energy consumption
- Small footprint
- Silent operation
- Advanced communication

## APPLICATIONS

- Entertainment systems
- Personal computers
- xDSL connections
- POS systems

The SoHo market is becoming more and more important, covering the market sector that includes professionals, small businesses and freelance professionals working from home. No less important are domestic consumers, with the rise of entertainment devices and media centres requiring ever higher quality power supply and protection from interference and black-outs.

### LOW ENERGY CONSUMPTION

Reducing energy consumption has become an economical necessity as well as an environmental obligation. It is therefore essential to choose UPS that employ green technology such as those made by Riello UPS, designed to

achieve the best energy efficiency and lowest environmental impact, whilst still providing the best possible performance.

### SMALL FOOTPRINT

The small footprint of Riello's UPS allow them to be easily installed anywhere in the office work space, without creating any interference with customer areas. There are also rack versions.

### SILENT OPERATION

In the workplace and above all in the home, the silent operation of equipment is very important. This is why our UPS are equipped with a sophisticated microprocessor control system able to reduce the speed of the fans and switch

them off when not required.

The entire Off-line range offers maximum silent operation thanks to the employment of high frequency components and the absence of moving parts, the noise level is equal to 0 dbA.

### ADVANCED COMMUNICATION

Riello UPS's UPS are equipped with USB and RS232 communication ports, allowing for full management and communication with the UPS to preserve data and make your IT systems secure.

UPS with LI and OL technology are also equipped with expansion slots to house the various different communication options offered by Riello UPS.



## Datacentre Area

### RECOMMENDED PRODUCTS

#### Multi Sentry



#### Multi Power



#### Master HP/HE



#### NextEnergy



#### Sentinel Pro



#### Vision Dual



### REFERENCES

#### China

- China Mobile

#### Korea

- Telecom

#### Germany

- Sun Microsystems
- German Government
- Deutsche Bank
- Allianz

#### India

- Samsung India Electronics
- Sify

#### Italy

- Poste Italiane
- Telecom Italia
- ENI
- Enel

#### Malaysia

- CSF

#### Spain

- Globalswitch
- Cellnex

#### United Kingdom

- ServerChoice
- UniLever

### FEATURES

- Extremely high availability
- Low energy consumption
- Small footprint
- Flexible configurations

### APPLICATIONS

- Data centres
- Server farms
- Large databases
- Telecommunications and IT
- Banks and insurance companies

Data centres represent one of a company's most fundamental assets: a structure on which the entire organisation depends. This is why it is important to ensure these systems are both functional and reliable, starting from the correct electrical layout of the system and following precise quality criteria.

#### AVAILABILITY

According to the TIER standard, system availability should fall between 99.9 and 99.9999%: downtime is not an option. Using high quality Riello UPS uninterruptible power supplies in a well-designed system,

this level of availability can be achieved. The UPS must be versatile, compact and parallelable in order to provide the required flexibility; they should be able to adapt to all types of load, both inductive and capacitive, and should also be able to integrate with the other components in the system (e.g. electrical generators).

#### ENERGY CONSUMPTION

Reducing energy consumption has become a necessity for all businesses as well as an environmental concern. It is therefore fundamental to choose a UPS supplier that offers green products designed to

provide the best energy efficiency and lowest environmental impact possible, with maximum performance. The **Eco Energy Levels** help identify the most highly efficient Riello UPS products.

#### PHYSICAL SPACE

It is critical to optimise the space available in data centres. Virtualising servers helps, but it is also useful to choose UPS with small footprints in order to avoid wasting space. The **Multi Sentry**, **Master HP**, **Multi Power** and **NextEnergy** UPS ranges have some of the smallest footprints available on the market.





## E-Medical Area

### RECOMMENDED PRODUCTS

#### Sentinel Pro



#### Master MPS



#### Multi Sentry



#### Multi Power



### REFERENCES

#### Austria

- Country Hospital Graz
- Krankenhaus (LKH) Salzburg

#### France

- Clinique De La Sauvegarde - Lyon
- Tropical Medicine Centre - Marseille
- Civil Hospital - Lyon

#### Germany

- Klinikum Süd Nürnberg
- Universität-klinikum Aachen

#### Italy

- Ospedale le Molinette - Turin
- Ospedale Cardarelli - Naples

#### Korea

- E-HWA University Hospital - Seoul

#### Spain

- Biomedical Research Park - Barcelona

#### Sri Lanka

- Apollo Hospital - Colombo

### FEATURES

- Extreme protection for critical applications
- High resilience
- Compliant with specific standards

### APPLICATIONS

- Back up of auxiliary power supply systems
- Operating theatres
- Hospital services

More and more sectors of the economy now rely on technology. Even medical and healthcare services now generally rely on digital technologies. Due to the critical nature of these applications, which are closely linked with personal well being, the services and infrastructure must be designed to ensure maximum levels of reliability and operating safety.

#### SAFETY

According to the standards that apply to the sector, all medical equipment must adhere to stringent safety standards. Based on the type of application, the UPS must ensure immunity from external influences,

providing compatibility with: IP protection levels, input/output electrical isolation, the possibility of housing internal isolation transformers and auxiliary monitoring systems for electrical values. Riello UPS responds to all needs with products suited for all power and safety requirements connected with different applications.

#### RELIABILITY

In a medical context reliable services are critical and therefore the choice of UPS should favour the best technological solutions (on line dual conversion). These guarantee compatibility with all levels

of architecture aimed at increasing the availability and resilience of the system (parallelability and redundancy of power supply in accordance with the TIER standard).

Electrical continuity cannot be guaranteed unless it is supported by suitable monitoring and control systems, which should be flexible and adaptable to the various systems and protocols installed in healthcare infrastructures. Riello UPS develops, tests and perfects its products as well as the different monitoring and control systems in-house, guaranteeing complete flexibility with different protocols and a rapid response to any interface problems.



## Industry Area

### RECOMMENDED PRODUCTS

#### Sentinel Pro



#### Multi Guard Industrial



#### Master MPS



#### SuperCaps UPS



#### Master Industrial



### REFERENCES

#### Germany

- Mannesmann
- Audi
- Adidas

#### India

- Metlon Industry

#### Italy

- Benetton Treviso
- Pirelli Milano
- Ilva
- La Doria
- Fincantieri

#### Spain

- Repsol

#### Sweden

- Ericsson
- Saab

#### Russia

- Ece

#### UK

- Glaxo Smith Kline
- Corus

### FEATURES

- Extremely high reliability and strength
- Customisable
- Compatible with long autonomy times
- ModBus and Profibus support

### APPLICATIONS

- Oil & Gas
- Power Generation, T&D
- Water treatment
- Instruments and process monitoring
- Emergency systems

Complex industrial installations are particularly critical and therefore require an exceptional level of resilience and reliability under all operating and environmental conditions. The UPS is a fundamental asset for guaranteeing service continuity and system safety. Riello UPS's industrial solutions have been protecting oil and gas infrastructures, power stations and other industrial installations for decades, making Riello UPS the *industrial* partner for every business in the sector.

#### RELIABILITY

Operating continuity is fundamental in the industrial sector; a power shutdown or a

breakdown in the supply of monitoring/control information cannot be tolerated. This is why high quality Riello UPS uninterruptible power supplies are used: versatile, technologically advanced and suitable for operation in varied environmental conditions (temperature, humidity, vibrations, fluctuating power supplies, etc.).

#### STRENGTH

In the industrial sector UPS are often required to provide a high level of compatibility with stringent mechanical standards (IP protection level > 21, protection against vibration, structural rigidity). In addition to this, in order to fulfil general requirements, the use

of filters, isolated electrical connectors and special wiring (halogen free, etc) is often required, as well as fastening components and systems that are highly resistant to mechanical stresses.

#### FLEXIBILITY AND CUSTOMISATION

The UPS Riello are flexible, i.e. they can be adapted to different power sources (single phase, three-phase, with or without neutral), they can be configured with isolation transformers not only at the output but also at the rectifier and bypass. They are compatible with various remote control communication protocols and can be customised to the specific requirements of any system.





## Transport Area

### RECOMMENDED PRODUCTS

#### Master HP/HE



#### Multi Guard Industrial



#### Master MPS



#### Master FC400



### REFERENCES

#### Germany

- Munich airport
- Hamburg railway station

#### Italy

- Underground railway Rome
- Underground railway Turin
- Malpensa Airport

#### Spain

- Barajas Airport, Madrid
- High Speed Train A.V.E.

#### France

- CDG airport Paris
- Underground railway Paris

#### South Africa

- Johannesburg International Airport

#### United Arab Emirates

- Underground railway Dubai
- Etihad Airway
- Megacargo terminal Dubai

#### China

- Peking airport
- Underground Railway Nanjing
- Underground Railway Hong Kong

#### India

- Delhi underground railway

### FEATURES

- Protection for critical application
- Adaptability to different environments
- Flexibility of power supply
- Extremely resilient

### APPLICATIONS

- Railway stations
- Airports
- Toll gates
- Marinas

The infrastructure used in the transport sector is increasingly technologically advanced and complex. At the same time however, it must also provide an exceptional level of resilience and reliability under all operating and environmental conditions. UPS and power continuity play a major role in guaranteeing continuity and excellence in the services provided.

#### FLEXIBILITY OF INSTALLATION

Every application in the transport infrastructure sector has its own particular specifications and associated reference standards.

It is therefore fundamental that the UPS are adaptable to different power sources (single phase, three-phase, with or without neutral),

and compatible with various remote control communication protocols, which should be complete, rapid and effective.

#### GLOBAL STRENGTH

The need to ensure service continuity requires high levels of compatibility with stringent mechanical standards (IP protection, vibrations, structural rigidity). The use of air filters, isolated electrical connectors and special wiring is often required in order to fulfil general requirements, as well as fastening components and systems that are highly resistant to mechanical stresses. Riello UPS is able to offer tailor-made solutions that satisfy the requirements of special standards or particular operating conditions.

#### RELIABILITY

Operational continuity is strategic to the transport sector. Downtime with regards to power supply or monitoring/control information cannot be tolerated. Continuity can be guaranteed by using high quality UPS that are versatile, technologically advanced and parallelable, which are able to operate under critical environmental conditions (temperature, fluctuating power supplies, different types of load, etc.). Riello UPS with its range of transformer-less and transformer-based products is able to satisfy the most diverse and complex requirements to ensure operating continuity and reliability for users.



## Emergency Area

### RECOMMENDED PRODUCTS

#### Sentinel Pro



#### Master MPS



#### Sentinel Power



#### CSS 1h to 3h



### FEATURES

- High reliability
- Compliant with standard EN 50171
- Batteries with 10 year life (at 20°C)
- Casing compliant with EN 60598-1
- Advanced diagnostics

### APPLICATIONS

- Hospitals
- Railway stations
- Stadiums and sports centres
- Shopping centres
- Schools
- Public buildings

### REFERENCES

#### Italy

- Juventus Stadium

#### Germany

- Allianz Arena

#### South Africa

- Ellispark Stadium
- Loftus Stadium

#### Spain

- Barcelona Olympic Stadium

#### Czech Republic

- Slavia Stadium Prague

Riello UPS centralised power supplies are designed for buildings subject to fire prevention safety standards.

Designed and built in compliance with standard EN 50171 CPSS (Central Power Supply Systems) and other guidelines. These systems are designed mainly to provide emergency lighting in the event of a power blackout, however, they can also be used for other emergency systems, such as for example:

- automatic fire prevention systems,
- alarm units and emergency detection systems,

- smoke extraction equipment,
- carbon monoxide detection systems,
- specific safety systems in sensitive areas.

The main features of Riello UPS solutions are summarised here:

- Regulatory compliance
- Autonomy of up to 3 h (and beyond on request)
- Battery recharge time under 12 hours
- Battery monitoring system
- Galvanic isolation of input/output (optional)

- Advanced diagnostics (information on display panel)
- Interface device to provide information remotely
- High short circuit current.

This is joined by Riello UPS's long term experience in emergency applications, with thousands of installations all over the world.









# UPS Standard



SOHO

# iPlug



UPS VFD



Tower



**1:1** 600-800 VA



USB  
plug



GS Nemko  
certified



Plug & Play  
installation

## HIGHLIGHTS

- Compact
- Versatile
- Robust
- Contemporary design
- Auto restart
- Battery swap

The iPlug series is the ideal solution for protecting household and small office systems. Its compact size and versatility (push-button operation, LED status panel and user replaceable batteries), make iPlug easy to install within a domestic environment to protect systems from surges and blackouts.

When the mains fails, the load is powered from a pseudo-sine wave inverter, to provide sufficient runtime for computer system shutdown using PowerShield<sup>3</sup> software, which can be downloaded free from [www.riello-ups.com](http://www.riello-ups.com)

### Versatile, robust and contemporary design

The iPlug's compact and ergonomic design allow it to be easily installed in professional and domestic environments. iPlug is extremely versatile and its innovative cable management feature ensures a tidy, easy to manage installation.

### Advanced communications

PowerShield<sup>3</sup> software allows for the safe shutdown of connected IT systems on mains power supply failure. PowerShield<sup>3</sup> provides efficient and intuitive

UPS management using bar chart displays for important operating information.

### Auto restart

The UPS automatically restarts upon the restoration of mains power after having shut down once the batteries have run out following a black out (Auto restart).

### Environmental protection ECO Line

With energy savings in mind, the iPlug range features a shut-off button to reduce energy consumption during periods of prolonged inactivity.

### Applications

LCD monitors, personal computers, video terminals, printers, scanners and fax machines.

### Features

- Compact and ergonomic
- 5 sockets protected against black-outs
- 3 sockets protected against overvoltage for the supply of loads with larger absorption loads e.g laser printers
- Ability to switch on the UPS without a mains power supply (Cold Start)
- User replaceable batteries (Battery Swap)
- USB interface
- Floor-standing or desktop installation
- Power-supply cable included
- Built-in short circuit protection
- Auto restart (when mains power is restored, after discharge of the batteries)
- GS/Nemko safety seal
- Available with French (2P+T), British, Schuko and Italian outlets.
- PowerShield<sup>3</sup> supervision and shutdown software for Windows operating systems 10, 8, 7, Hyper-V, 2016, 2012, and previous

- versions, Mac OS X, Linux.
- Plug and play function.

### 2-YEAR WARRANTY

### CONFIGURATOR FOR MODEL SELECTION

Load type	VA power rating *
Personal computers	250
LCD Monitors	70
Scanners, printers	200
Modems, TVs, DVD players, PlayStations, Hi-Fi systems, telephones, Faxes	50
Laser printers **	200

\* Estimated average value.

\*\* iPlug filtered output power supply is recommended.

### AVAILABLE SOCKETS



SCHUKO SOCKET  
CEE 7/7P



FRENCH SOCKET  
CEE 7/5



ITALIAN SOCKET  
CEI 23/16



BRITISH SOCKET  
BS1363A

### AVAILABLE OPTIONS

#### SOFTWARE

PowerShield<sup>3</sup>

### DETAILS

FILTERED SOCKETS: PROTECTED AGAINST OVERVOLTAGE ONLY

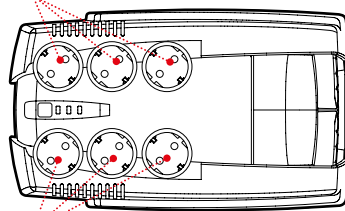

SOCKETS WITH UPS PROTECTION (NO BREAK IN POWER IF MAINS FAILS)

IEC SOCKETS WITH UPS PROTECTION      USB COMMUNICATION PORT

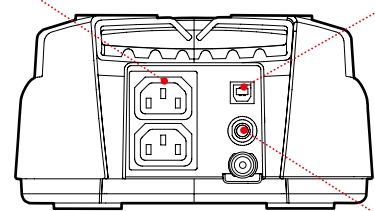

SAFETY FUSE



<b>MODELS</b>	<b>IPG 600</b>	<b>IPG 800</b>
<b>POWER</b>	<b>600 VA/360 W</b>	<b>800 VA/480 W</b>
<b>INPUT</b>		
Nominal voltage	220-240 Vac	
Voltage tolerance	230 Vac (+20/-25%)	
Frequency	50/60 Hz with automatic selection	
<b>OUTPUT</b>		
Voltage during mains operation	230 Vac (+20/-25%)	
Voltage during battery operation	230 Vac (+/- 10%)	
Frequency during battery operation	50 or 60 Hz (+/- 1%)	
Waveform	Pseudo Sinusoidal	
<b>BATTERIES</b>		
Type	VRLA AGM maintenance-free lead based	
Recharge time	6-8 hours	
<b>OTHER FEATURES</b>		
Net weight (kg)	3.7	4.1
Gross weight (kg)	4	4.4
Dimensions (WxDxH) (mm)	185 x 313 x 99	
Packaging dimensions (WxDxH) (mm)	260 x 380 x 140	
Protections	Excessive low battery - overvoltage - short circuit	
Communications	USB	
Output sockets	6 sockets (Schuko or Italian or French or British) + 2 IEC 320 C13	
Standards	EN 62040-1-1 and Directive 2006/95/EC; EN 62040-3 EN 62040-2 and Directive 2004/108 EC	
Certificates	CE; GS/NEMKO on Schuko version	
Operating temperature	0 °C / +40 °C	
Colour	Black	
Altitude and relative humidity	6000 m max altitude, < 95% non-condensing	
Equipment provided	power cable, user guide	







SOHO

# iDialog



UPS VFD



Tower



**1:1** 400-1600 VA



USB  
plug



Plug & Play  
installation

## HIGHLIGHTS

- **Compact**
- **Silent operation**
- **Contemporary design**
- **Auto restart**
- **Low power consumption**

The iDialog range is the ideal solution for protecting PCs and peripherals in the home and office.

iDialog is easy to install and economic to run for protecting:

- IT equipment such as PCs, Media Centres and peripherals, TVs, Home Cinema systems, Satellite and Digital Terrestrial Receivers and DVD recorders and players;
- xDSL modems and routers;
- Small home appliances.

### Silent operation

The UPS is silent in operation (0 dBA) thanks to its use of a fan-less design and high frequency components.

### Advanced communications

PowerShield<sup>3</sup> software allows for the safe shutdown of connected IT systems on mains power supply failure. PowerShield<sup>3</sup> provides efficient and intuitive UPS management using bar chart displays for important operating information.

### Auto restart

The UPS automatically restarts when the mains power supply is restored.

MODELS	IDG 400	IDG 600	IDG 800	IDG 1200	IDG 1600
<b>POWER</b>	<b>400 VA/240 W</b>	<b>600 VA/360 W</b>	<b>800 VA/480 W</b>	<b>1200 VA/720 W</b>	<b>1600 VA/960 W</b>
<b>INPUT</b>					
Nominal voltage	220-240 Vac				
Voltage tolerance	230 Vac (+20/-25%)				
Frequency	50/60 Hz with automatic selection				
<b>OUTPUT</b>					
Voltage during mains operation	230 Vac (+20/-25%)				
Voltage during battery operation	230 Vac (+/- 10%)				
Frequency during battery operation	50 or 60 Hz (+/- 1%)				
Waveform	Pseudo Sinusoidal				
<b>BATTERIES</b>					
Type	VRLA AGM maintenance-free lead based				
Recharge time	6-8 h				
<b>OTHER FEATURES</b>					
Net weight (kg)	3.2	3.4	6.6	6.9	
Gross weight (kg)	3.7	4.1	8.1	8.6	
Dimensions (WxDxH) (mm)	90 x 232 x 192			93 x 310 x 270	
Packaging dimensions (WxDxH) (mm)	138 x 300 x 278			170 x 400 x 370	
Protections	Excessive low battery - overvoltage - short circuit				
Communications	USB			USB + RS232	
Output sockets	4 IEC 320 C13			6 IEC 320 C13	
Standards	EN 62040-1-1 and Directive 2006/95/EC; EN 62040-3 EN 62040-2 and Directive 2004/108 EC				
Certificates	CE				
Operating temperature	0 °C / +40 °C				
Colour	Black				
Altitude and relative humidity	6000 m max altitude, <95% non-condensing				
Standard equipment	2 output power supply cables, user manual				

## ECO Line environmental protection

With energy savings in mind, the iDialog range features a shut-off button to reduce energy consumption during periods of prolonged inactivity.

## Features

- Reduced energy consumption and 99% efficiency
- Maximum reliability and protection of PCs thanks to PowerShield<sup>3</sup> monitoring and shutdown software, which can be downloaded free at [www.riello-ups.com](http://www.riello-ups.com)
- Can be installed on PCs with Windows operating systems 10, 8, 7, Hyper-V, 2016, 2012, and previous versions, Mac OS X, Linux.

- Small size: With its compact shape, iDialog can be placed anywhere on the desk or in the home.
- Silent: iDialog is also suitable for protecting your non-professional digital equipment such as home cinema systems, satellite and digital terrestrial receivers and DVD players/recorders.

## 2-YEAR WARRANTY

## AVAILABLE OPTIONS

### SOFTWARE

PowerShield<sup>3</sup>

## DETAILS

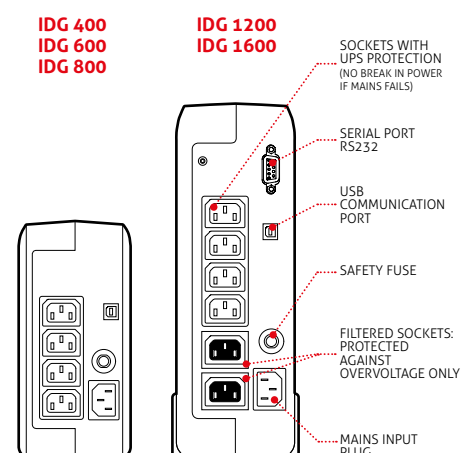



SOHO

# iDialog Rack



UPS VFD



Rack



**1:1** 600-1200 VA



USB plug



Plug & Play installation

## HIGHLIGHTS

- Design for telco rack
- Silent operation
- Auto restart
- Low power consumption

### Maximum reliability in the protection of Voip systems

The iDialog Rack range is the ideal solution for protecting PCs and peripherals in the home and office.

iDialog Rack is easy to install and economic to run for protecting:

- IT equipment such as PCs, Media Centres and peripherals, TVs, Home Cinema systems, Satellite and Digital Terrestrial Receivers and DVD recorders and players;
- xDSL modems and routers;
- Voip and network application.

### Silent operation

The UPS is silent in operation (0 dBA ) thanks to its use of a fan-less design and high frequency components.

### Advanced communications

PowerShield<sup>3</sup> software allows for the safe shutdown of connected IT systems on mains power supply failure. PowerShield<sup>3</sup> provides efficient and intuitive UPS management using bar chart displays for important operating information.

### Auto restart

The UPS automatically restarts when the mains power supply is restored.

### ECO Line environmental protection

With energy savings in mind, the iDialog Rack range features a shut-off button to reduce energy consumption during periods of prolonged inactivity.



MODELS	IDR 600	IDR 1200
<b>POWER</b>	<b>600 VA/360 W</b>	<b>1200 VA/720 W</b>
<b>INPUT</b>		
Nominal voltage	220-240 Vac	
Voltage tolerance	230 Vac (+20/-25%)	
Frequency	50/60 Hz with automatic selection	
<b>OUTPUT</b>		
Voltage during mains operation	230 Vac (+20/-25%)	
Voltage during battery operation	230 Vac (+/- 10%)	
Frequency during battery operation	50 or 60 Hz (+/- 1%)	
Waveform	Pseudo Sinusoidal	
<b>BATTERIES</b>		
Type	VRLA AGM maintenance-free lead based	
Recharge time	6-8 h	
<b>OTHER FEATURES</b>		
Net weight (kg)	5.5	9
Gross weight (kg)	7	10.5
Dimensions (WxDxH) (mm)	438 x 230 x 87	438 x 300 x 87
Packaging dimensions (WxDxH) (mm)	503 x 330 x 211	503 x 400 x 211
Protections	Excessive low battery - overvoltage - short circuit	
Communications	USB + RS232	
Output sockets	2 IEC 320 C13 + 3 Shuko	
Standards	EN 62040-1-1 and Directive 2006/95/EC; EN 62040-3 EN 62040-2 and Directive 2004/108 EC	
Certificates	CE	
Operating temperature	0 °C / +40 °C	
Colour	Black	
Altitude and relative humidity	6000 m max altitude, <95% non-condensing	
Standard equipment	Rack handles, user manual	

## Features

- Reduced energy consumption and 99% efficiency.
- Maximum reliability and protection of PC s thanks to PowerShield<sup>3</sup> monitoring and shutdown software, which can be downloaded free at [www.riello-ups.com](http://www.riello-ups.com)
- Can be installed on PCs with Windows operating systems 10, 8, 7, Hyper-V, 2016, 2012, and previous versions, Mac OS X, Linux.
- Small size: With its compact shape, iDialog Rack can be placed in any small rack.
- Noise-free running: iDialog Rack is also suitable for protecting your non-professional digital equipment such as home cinema systems, satellite and digital terrestrial receivers and DVD players/ recorders.

## 2-YEAR WARRANTY

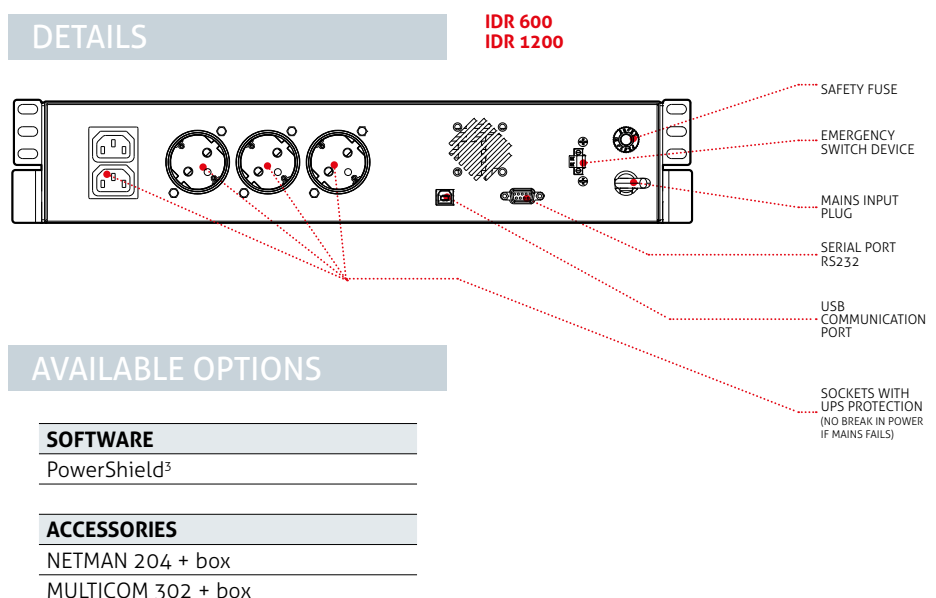



SOHO

# Net Power



LINE INTERACTIVE



Tower



**1:1** 600-2000 VA



USB plug



Plug & Play installation

## HIGHLIGHTS

- **Automatic Voltage Regulation (AVR)**
- **Advanced communications**
- **Automatic battery test**

The Net Power series is available in 600-2000 VA models with digital technology: when available the load is supplied from the mains power supply, which is amplitude-stabilised by the automatic voltage regulator (AVR) and filtered against overvoltages by EMI filters.

When the mains fails, the load is powered from a pseudo-sine wave inverter, to provide sufficient runtime for computer system shutdown using PowerShield<sup>3</sup> software, which can be downloaded free from [www.riello-ups.com](http://www.riello-ups.com)

### Features

- Stabilisation and filtering of the mains power supply using AVR and EMI filters for the suppression of atmospheric disturbances
- Ability to switch on the UPS in the absence

of mains power (Cold Start)

- High reliability with built-in battery test
- Auto restart (when mains power is restored, after discharge of the batteries)
- Supplied with two IEC cables for powering the loads.

### Advanced communications

- Advanced multi-platform communications for all operating systems and network environments: PowerShield<sup>3</sup> supervision and shutdown software for Windows operating systems 10, 8, 7, Hyper-V, 2016, 2012, and previous versions, Mac OS X, Linux, VMWare ESXi, Citrix XenServer and other Unix operating systems
- Standard USB interface, RS232 on models 1000 - 1500 - 2000.

### 2-YEAR WARRANTY

MODELS	NPW 600	NPW 800	NPW 1000	NPW 1500	NPW 2000
<b>POWER</b>	600 VA/360 W	800 VA/480 W	1000 VA/600 W	1500 VA/900 W	2000 VA/1200 W
<b>INPUT</b>					
Nominal voltage	220-230-240 Vac				
Voltage tolerance	230 Vac ( $\pm 25\%$ )				
Frequency	50/60 Hz with automatic selection				
<b>OUTPUT</b>					
Voltage during mains operation	230 Vac (-8%, +10%)				
Voltage during battery operation	230 Vac (+/- 5%)				
Frequency during battery operation	50 or 60 Hz (+/- 0.5%)				
Battery waveform	Pseudo sinusoidal				
<b>BATTERIES</b>					
Type	VRLA AGM maintenance-free lead based				
Recharge time	6-8 h		2-4 h		
<b>OTHER FEATURES</b>					
Net weight (kg)	4.3	4.9	8	11.1	11.5
Gross weight (kg)	5.6	6.3	10	13.5	14
Dimensions (WxDxH) (mm)	100 x 287 x 142		146 x 350 x 160	146 x 397 x 205	
Packaged dimensions (WxDxH) (mm)	140 x 332 x 220		195 x 440 x 250	230 x 480 x 280	
Protections	Excessive low battery - overvoltage - short circuit				
Display	LED		LCD		
Communications	USB		USB + RS232		
Output sockets	4 IEC 320 C13 sockets			6 IEC 320 C13 sockets	
Standards	EN 62040-1-1 and Directive 2006/95/EC; EN 62040-2 and Directive 2004/108 EC				
Certificates	CE				
Operating temperature	0 °C / +40 °C				
Colour	Black				
Altitude and relative humidity	6000 m max altitude, <95% non-condensing				
Standard equipment	2 cables for powering loads; user manual				

## AVAILABLE OPTIONS

### SOFTWARE

PowerShield<sup>3</sup>

### ACCESSORIES

NETMAN 204 + box  
(only NPW 1000-2000)

MULTICOM 302 + box  
(only NPW 1000-2000)

## DETAILS

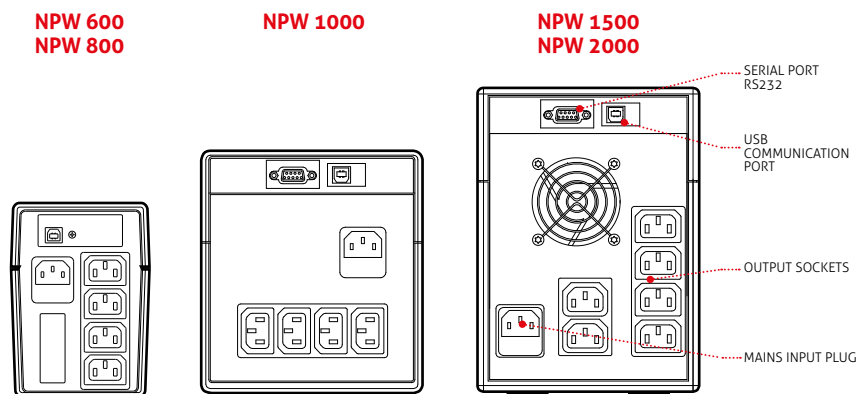



SOHO

# Vision



LINE INTERACTIVE



Tower



**1:1** 800-2000 VA



USB plug



Hot swap battery



Plug & Play installation



GS Nemko certified

## HIGHLIGHTS

- Superior protection
- Compact and contemporary design
- High availability
- Versatility
- LCD display
- Automatic Voltage Regulation (AVR)

The Vision range is available in models from 800 VA to 2000 VA with sinusoidal digital technology.

The Vision range, with its advanced communications and connectivity options, is the ideal solution for installations requiring superior protection and versatility in the power supply system. Vision is the ideal solution for the protection of peripheral network devices, servers, and network back-up systems.

### Superior protection

The Vision range uses Line Interactive technology and provides a sinusoidal output. This technology provides efficiency levels of 98% and therefore reduced energy consumption. It also ensures a high level of protection against mains power disturbances.

The automatic voltage regulator (AVR) provides protection from surges, overvoltages and undervoltages, without battery intervention. Reduced battery usage ensures that the battery set is 100% available for mains power supply failures and is able to provide greater autonomy. EMI filters then provide further protection from voltage surges and transients. When the mains power supply fails, the load is powered by the inverter and receives a perfectly sinusoidal supply for maximum power continuity and reliability. With energy savings in mind, the Vision range features a shut-off button to reduce energy consumption to zero during periods of prolonged inactivity.



## High availability

An EnergyShare socket allows load-shedding and the shutdown of less sensitive peripheral devices to extend battery runtime for critical loads. "Hot Swap" batteries can be removed via the front panel for easy and safe UPS maintenance. Battery test facility to detect deteriorating battery performance. Deep discharge protection to reduce battery ageing.

## Versatility

Cold Start function to allow the UPS to power up with no mains power supply present.

## LCD display

Vision models have a backlit LCD display providing UPS status information, load and battery performance.

## Advanced communications

- Advanced multi-platform communications for all operating systems and network environments: PowerShield<sup>3</sup> monitoring and shutdown software for Windows operating systems 10, 8, 7, Hyper-V, 2016, 2012, and previous versions, Mac OS X, Linux, VMWare ESXi, Citrix XenServer and other Unix operating systems.
- USB or RS232 serial port interface (selectable)
- Expansion slot for interface boards
- Status, measurements, alarms and input, output and battery parameters available on LCD display.

## Features

- EnergyShare socket
- Ability to switch on the UPS in the absence of mains power (Cold Start)
- Batteries are user replaceable without switching off equipment and without interruption to the load (Hot Swap)
- Maximum reliability and protection of PCs thanks to PowerShield<sup>3</sup> monitoring and shutdown software, which can be downloaded free at [www.riello-ups.com](http://www.riello-ups.com)
- Fully configurable using UPS Tools configuration software
- Highly reliable batteries (automatic and manually-activated battery test)
- Built-in short circuit protection
- Auto restart (when mains power is restored, after discharge of the batteries)
- GS/Nemko safety seal

## 2-YEAR WARRANTY



## AVAILABLE OPTIONS

### SOFTWARE

PowerShield<sup>3</sup>  
PowerNetGuard

### ACCESSORIES

NETMAN 204  
MULTICOM 302

MULTICOM 352

MULTICOM 372

MULTICOM 384

MULTI I/O

MULTIPANEL

## DETAILS

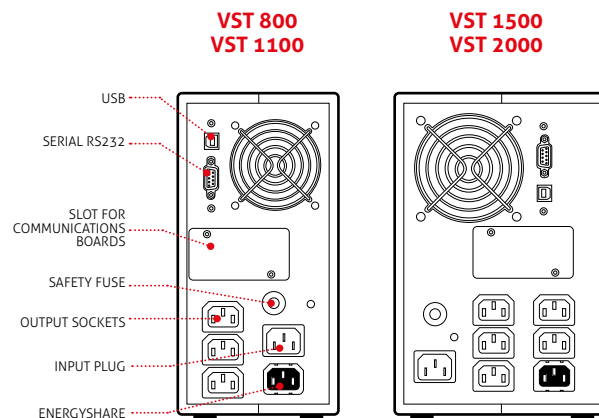

MODELS	VST 800	VST 1100	VST 1500	VST 2000
<b>POWER</b>	<b>800 VA/640 W</b>	<b>1100 VA/880 W</b>	<b>1500 VA/1200 W</b>	<b>2000 VA/1600 W</b>
<b>INPUT</b>				
Nominal voltage	220 - 230 - 240 V selectable			
Voltage tolerance	162 V - 290 V			
Frequency	50/60 Hz with automatic selection			
Frequency tolerance	±5%			
<b>OUTPUT</b>				
Nominal voltage	220 - 230 - 240 V selectable			
Frequency	50 or 60 Hz with automatic selection			
Waveform	Sinusoidal			
<b>BATTERIES</b>				
Type	VRLA AGM maintenance-free lead based			
Recharge time	4-6 h			
<b>OTHER FEATURES</b>				
Net weight (kg)	10.5	11.3	16.5	18.5
Gross weight (kg)	12.2	13	18.4	20.4
Dimensions (WxDxH) (mm)	120 x 443 x 247		160 x 443 x 247	
Packaging dimensions (WxDxH) (mm)	208 x 530 x 342		250 x 540 x 354	
Protections	Overload - short-circuit - overvoltage - undervoltage - temperature - excessive low battery			
Communications	USB / RS232 / slot for communications interface			
Input plugs	1 IEC 320 C14			
Output sockets	4 IEC 320 C13		6 IEC 320 C13	
Standards	EN 62040-1-1 and Directive 2006/95/EC EN 62040-2 and Directive 2004/108 EC			
Operating temperature	0 °C / +40 °C			
Storage temperature	-15 °C / 45 °C			
Colour	Black			
Relative humidity	<95% non-condensing			
Noise	< 40 dBA			





# Vision Rack



SOHO



DATA CENTRE



LINE INTERACTIVE



Rack



**1:1** 800-1100 VA



USB plug



Hot swap battery



Energy share



Plug & Play installation

## HIGHLIGHTS

- Superior protection
- High availability
- Versatility
- LCD display
- Automatic voltage regulation (AVR)

The Vision Rack range is available in models from 800 VA to 1100 VA with sinusoidal digital technology.

The Vision Rack range, with its advanced communications and connectivity options, is the ideal solution for installations requiring superior protection and versatility in the power supply system. Vision Rack is the ideal solution for the protection of peripheral network devices, servers, and network back-up systems.

### Superior protection

The Vision Rack range uses Line Interactive technology and provides a sinusoidal output

voltage. This technology provides efficiency levels of 98% and therefore reduced energy consumption. It also ensures a high level of protection against mains power disturbances.

The automatic voltage regulator (AVR) provides protection from surges, overvoltages and undervoltages, without battery intervention.

Reduced battery usage ensures that the battery set is 100% available for mains power supply failures and is able to provide greater autonomy.

EMI filters then provide further protection from voltage surges and transients.



When the mains power supply fails, the load is powered by the inverter and receives a perfectly sinusoidal supply for maximum power continuity and reliability.

### High availability

An EnergyShare socket allows load-shedding and the shutdown of less sensitive peripheral devices to extend battery runtime for critical loads.

"Hot Swap" batteries can be removed via the front panel for easy and safe UPS maintenance.

Battery test facility to detect deteriorating battery performance.

Deep discharge protection to reduce battery ageing.

### Versatility

Cold Start function to allow the UPS to power up with no mains power supply present.

### Display

Vision models have a backlit LCD display providing UPS status information, load and battery performance.

### Advanced communications

Advanced multi-platform communications for all operating systems and network environments: PowerShield<sup>3</sup> monitoring and shutdown software for Windows operating systems 10, 8, 7, Hyper-V, 2016, 2012, and previous versions, Mac OS X, Linux, VMWare ESXi, Citrix XenServer and other Unix operating systems

- USB or RS232 serial port interface (selectable)
- Expansion slot for interface boards
- Status, measurements, alarms and input, output and battery parameters available on LCD display.

### Features

- EnergyShare socket
- Ability to switch on the UPS in the absence of mains power (Cold Start)
- User-replaceable battery set (Battery Swap)
- USB and RS232 interface

- Slot for communications boards
- Maximum reliability and protection of PCs thanks to PowerShield<sup>3</sup> monitoring and shutdown software, which can be downloaded free at [www.riello-ups.com](http://www.riello-ups.com)
- Highly reliable batteries (automatic and manually-activated battery test)
- Built-in short circuit protection
- Auto restart (when mains power is restored, after discharge of the batteries)
- Emergency power off contact (EPO).

### 2-YEAR WARRANTY

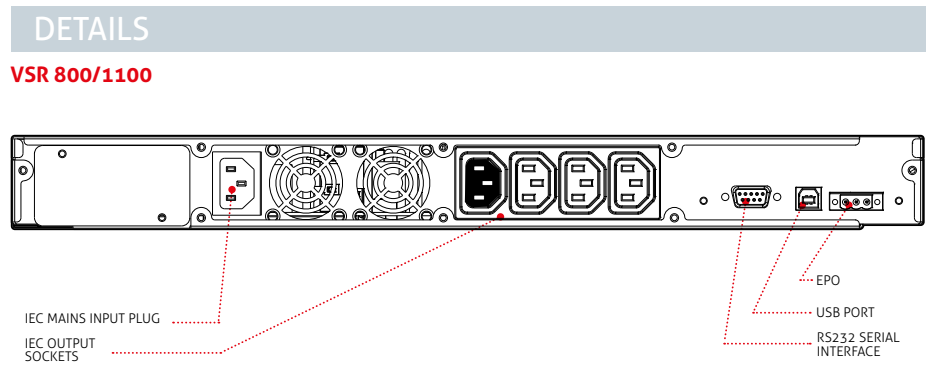

### OPTIONS

SOFTWARE
PowerShield <sup>3</sup>
PowerNetGuard

ACCESSORIES
NETMAN 204
MULTICOM 302
MULTICOM 352
MULTICOM 372

MULTICOM 384
MULTI I/O
MULTIPANEL

PRODUCT ACCESSORIES
Universal rails for installation in rack cabinets

MODELS	VSR 800	VSR 1100
<b>POWER</b>	<b>800 VA/640 W</b>	<b>1100 VA/880 W</b>
<b>INPUT</b>		
Nominal voltage	230 Vac (220, 240 V selectable)	
Voltage tolerance	162 V - 290 V	
Frequency	50/60 Hz with automatic selection	
Frequency tolerance	±5% (3% to 10% configurable)	
<b>OUTPUT</b>		
Nominal voltage	230 Vac (220, 240 V selectable)	
Frequency	50 or 60 Hz with automatic selection	
Waveform	Sinusoidal	
<b>BATTERIES</b>		
Type	VRLA AGM maintenance-free lead based	
Recharge time	4-6 h	
<b>OTHER FEATURES</b>		
Net weight (kg)	12	13
Gross weight (kg)	14.5	15.5
Dimensions (WxDxH) (mm)	19" x 420 x 1U	
Packaged dimensions (WxDxH) (mm)	595 x 540 x 140	
Protections	Overload - short-circuit - overvoltage - undervoltage - temperature - excessive low battery	
Communications	USB / RS232 / slot for communications interface	
Input plugs	1 IEC 320 C14	
Output sockets	4 IEC 320 C13	
Standards	EN 62040-1-1 and Directive 2006/95/EC; EN 62040-2 and Directive 2004/108 EC	
Operating temperature	0 °C / +40 °C	
Storage temperature	-15 °C / 45 °C	
Colour	Black	
Relative humidity	<95% non-condensing	
Noise	< 50 dBA	



# Vision Dual



SOHO



DATACENTRE



LINE INTERACTIVE



Tower Rack



**1:1** 1100-3000 VA



USB

USB plug



Hot swap battery



Energy share



Plug & Play installation

## HIGHLIGHTS

- Automatic Voltage Regulation (AVR)
- Superior protection
- High efficiency
- High availability
- Versatility
- Advanced communications

The Vision Dual range (tower and rack), includes models from 1100 VA to 3000 VA with sinusoidal digital technology.

The Vision Dual range, with its advanced communications and connectivity options, is the ideal solution for installations requiring superior protection and versatility in the power supply system.

Vision Dual is the ideal solution for the protection of peripheral network devices, conventional or rack servers, and network back-up systems. Vision Dual has a practical, modern design and includes several performance advantages over traditional on-line UPS. All developed by the Riello UPS research and development team.

The UPS provides efficiency levels of 98%

and therefore reduced energy consumption. It has an output power factor of 0.9.

### Superior protection

The automatic voltage regulator (AVR) provides protection from surges, overvoltages and undervoltages, without battery intervention. Reduced battery usage ensures that the battery set is 100% available for mains power supply failures and is able to provide greater autonomy. EMI filters then provide further protection from voltage surges and transients. When the mains power supply fails, the load is powered by the inverter and receives a perfectly sinusoidal supply for maximum power continuity and reliability.



## High availability

An EnergyShare socket allows load-shedding and the shutdown of less sensitive peripheral devices to extend battery runtime for critical loads.

"Hot Swap" batteries can be removed via the front panel for easy and safe UPS maintenance. For business continuity applications requiring long battery runtimes, battery autonomy can be extended up to several hours using ER models (versions 2200 and 3000) fitted with more powerful battery chargers.

Battery test facility to detect deteriorating battery performance.

Deep discharge protection to reduce battery ageing.

## Versatility

Vision Dual can be installed as a tower or in 19" rack cabinets. The display panel can be easily removed and rotated to suit the type of installation required.

Vision Dual is equipped with an emergency power off (EPO) contact that allows for remote shutdown in emergency situations. Cold Start function to allow the UPS to power up with no mains power supply present.

Vision Dual models have a backlit LCD display providing UPS status information, load and battery performance.

## Advanced communications

- Advanced multi-platform communications

for all operating systems and network environments: PowerShield<sup>3</sup> monitoring and shutdown software included, with SNMP agent, for Windows operating systems 10, 8, 7, Hyper-V, 2016, 2012, and previous versions, Mac OS X, Linux, VMWare ESXi, Citrix XenServer and other Unix operating systems

- USB or RS232 serial port interface (selectable)
- Expansion slot for SNMP agent interface boards
- Status, measurements, alarms and input, output and battery parameters available on LCD display.

## 2-YEAR WARRANTY



## DETAILS

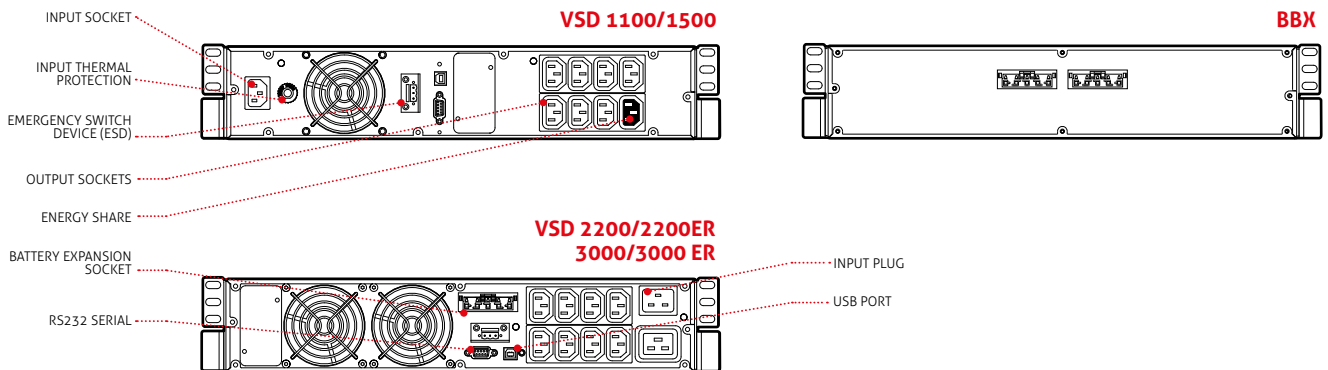

## OPTIONS

### SOFTWARE

PowerShield<sup>3</sup>  
PowerNetGuard

### ACCESSORIES

NETMAN 204  
MULTICOM 302  
MULTICOM 352  
MULTICOM 372  
MULTICOM 384  
MULTI I/O  
MULTIPANEL

Manual Bypass 16 A  
Manual Bypass 16 A Rack  
Automatic Bypass 16 A  
Automatic Bypass 16 A Rack

### PRODUCT ACCESSORIES

Universal rails for installation in rack cabinets

## BATTERY BOX

### MODELS

BB SDH 72-A3  
BB SDH 72-M1

Dimensions (mm)

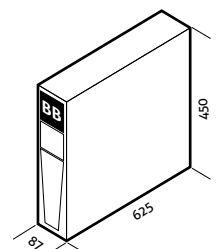

MODELS	VSD 1100	VSD 1500	VSD 2200	VSD 2200 ER	VSD 3000	VSD 3000 ER
<b>POWER</b>	<b>1100 VA/990 W</b>	<b>1500 VA/1350 W</b>	<b>2200 VA/1980 W</b>	<b>2200 VA/1760 W</b>	<b>3000 VA/2700 W</b>	<b>3000 VA/2400 W</b>
<b>INPUT</b>						
Nominal voltage	220-230-240 Vac					
Voltage range without battery intervention	162 Vac < Vin < 290 Vac					
Voltage tolerance	162-290 Vac					
Maximum permitted voltage	300 V					
Nominal frequency	50 or 60 Hz ±5Hz					
Frequency range	50 Hz ± 5% / 60 Hz ± 5%					
Power factor	> 0.98					
Current distortion	≤7%					
<b>OUTPUT</b>						
Voltage distortion with linear load / with non-linear load	< 3% / < 8%					
Frequency	Selectable: 50 Hz or 60 Hz or self-learning					
Waveform	Sinusoidal					
Current crest factor	2.5 : 1					
Efficiency ECO and Smart Active Modes	98.5%					
Overload Times	125% for 10 seconds, 150% for 1 second					
<b>BATTERIES</b>						
Type	VRLA AGM maintenance-free lead based					
Recharge time	2-4 hours					
<b>OTHER FEATURES</b>						
Net weight (kg)	16.5	17.5	28	15.5	31.5	16.5
Gross weight (kg)	20	21	33	20.5	36.5	21.5
Dimensions (WxDxH) (mm)	87 x 450 x 425 (2U x 19" x 425)			87 x 450 x 625 (2U x 19" x 625)		
Packaged dimensions (WxDxH) (mm)	240 x 500 x 600			240 x 600 x 760		
Protection against overvoltages	300 joules					
Protections	Overcurrent - short-circuit - overvoltage - undervoltage - temperature - excessive low battery					
Communications	USB / DB9 with RS232 and contacts / Slot for communications interface					
Input plugs	1 IEC 320 C14			1 IEC 320 C20		
Output sockets	8 IEC 320 C13			8 IEC 320 C13 + 1 IEC 320 C19		
Standards	Safety: EN 62040-1 and Directive 2006/95/EL; EMC: EN 62040-2 and Directives 2004/108/EL					
Operating temperature	0 °C / +40 °C					
Relative humidity	<95% non-condensing					
Colour	Black					
Noise level at 1 m (ECO Mode)	< 40 dBA					
Standard equipment provided	Power cable, serial cable, USB cable, safety manual, quick start guide, user manual on CD-ROM					







# Sentinel Pro



SOHO



INDUSTRY



E-MEDICAL



EMERGENCY



ONLINE



Tower



**1:1** 700-3000 VA



USB plug



GS Nemko certified



Supercaps UPS



Plug & Play installation

## HIGHLIGHTS

- Power factor 0.9
- Operating flexibility
- Emergency function
- Battery optimisation
- Runtime expandability
- Low noise level

Sentinel Pro has a unique and modern design and improved performance developed by the Riello UPS research and development team. Sentinel Pro uses on-line double conversion technology, resulting in the highest levels of reliability and maximum protection for critical loads such as servers, and IT and voice/data applications.

For business continuity applications requiring long battery runtimes, battery autonomy can be extended up to several hours using ER models fitted with more powerful battery chargers. The front display panel has been entirely redesigned, adding an LCD display that

shows the input and output voltages, battery readings and UPS operating status information. The inverter and the microprocessor control stage has been completely redesigned to provide increased efficiency and greater configuration options. Maximum expandability: the Sentinel Pro is supplied as standard with a USB port and an expansion slot for protocol conversion or relay contacts boards.

With energy savings in mind, Sentinel Pro is also fitted with a shut-off button to reduce energy consumption to zero during prolonged periods of inactivity (ECO LINE). Sentinel Pro is available in 700 VA, 1000 VA, 1500 VA, 2200 VA and 3000 VA models.



## Operating flexibility

Different operating modes that can be programmed according to user requirements and the load to be powered have been introduced in order to reduce energy consumption.

- **On line:** maximum load protection and output voltage waveform quality
- **Eco Mode:** the UPS uses line interactive technology, with the load powered by the mains, reducing consumption and thus improving efficiency (up to 98%).
- **Smart Active Mode:** the UPS automatically selects on-line or line interactive operation, depending on the quality of the mains supply, checking the number, frequency and type of disturbances present.
- **Stand by Off (emergency):** the UPS supplies the load only when the mains fails. The inverter begins working with a progressive start-up sequence to prevent inrush currents.
- **Frequency converter** operation (50 or 60 Hz).



## Emergency function

This configuration ensures the operation of emergency systems that must be supplied in the event of a mains power failure, such as emergency lighting, fire detection/ extinguishing systems and alarms. When the mains power supply fails, the inverter begins powering the loads with a progressive start-up (Soft Start) in order to prevent overload. Sentinel Pro is compliant for installation in medium-voltage transformer rooms in accordance with applicable legislation, for the power supply with reserve charge of medium-voltage coils.

## Battery optimisation

The Sentinel Pro range has a deep discharge protection device to optimise battery life. Periodically the UPS carries out a battery efficiency test (which can also be manually activated); its wide input voltage tolerance range helps to reduce battery usage and maintain performance over time.

## Runtime expandability

Optional battery extension packs can be connected to increase UPS runtime. In addition the Sentinel Pro range includes ER versions with no internal batteries and more powerful battery chargers for longer runtimes.

## Low noise level

Thanks to the use of high frequency components and load-based fan speed control, the noise produced by the UPS is less than 40 dBA.

## Features

- Filtered, stabilised and reliable voltage: double conversion on-line technology (VFI compliant with IEC 62040-3) with filters for the suppression of atmospheric disturbances.
- High overload capability (up to 150%)
- Programmable Auto-restart when mains is restored
- Battery start-up (Cold Start)

## DETAILS

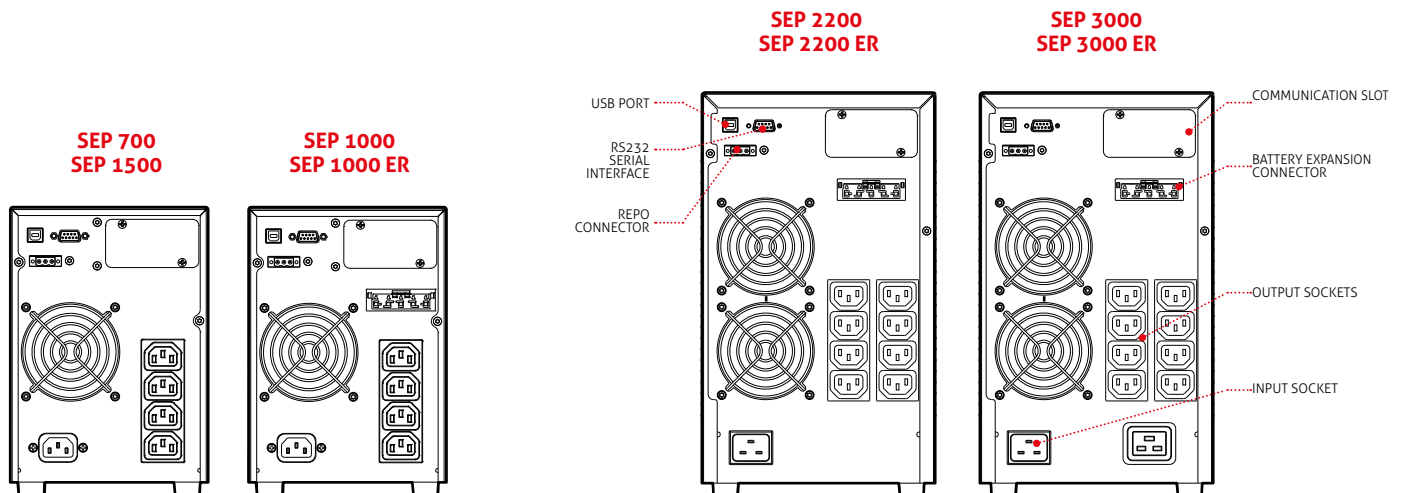

- Power factor correction (UPS input power factor, close to 1)
- Wide input voltage tolerance range (from 140 V to 276 V) without battery intervention.
- Runtime extendable up to several hours
- Fully configurable using UPS Tools configuration software
- Highly reliable batteries (automatic and manually-activated battery test)
- High level of UPS reliability (total microprocessor control)
- Low impact on the mains (sinusoidal take up).

### Advanced communications

- Multi-platform communication for all operating systems and network environments: PowerShield<sup>3</sup> supervision and shutdown software for Windows operating systems 10, 8, 7, Hyper-V, 2016, 2012, and previous versions, Mac OS X,

- Linux, VMWare ESXi, Citrix XenServer and other Unix operating systems
- UPS Tools configuration and customisation software supplied as standard
- RS232 serial port and opto-isolated contacts
- USB port
- Slot for communications boards.

### 2-YEAR WARRANTY

#### OPTIONS

##### SOFTWARE

PowerShield<sup>3</sup>  
PowerNetGuard

##### ACCESSORIES

NETMAN 204  
MULTICOM 302  
MULTICOM 352

MULTICOM 372  
MULTICOM 384  
MULTI I/O  
MULTIPANEL  
Manual Bypass 16 A  
Automatic Bypass 16 A

#### BATTERY BOX

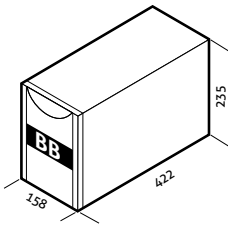
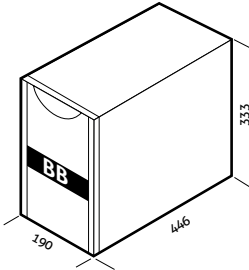
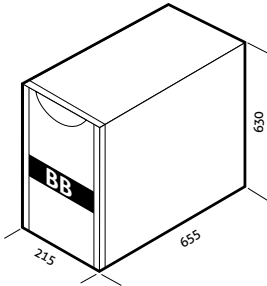
MODELS	BB SEP 36-A3 / BB SEP 36-M1	BB SEP 72-A3 / BB SEP 72-M1	BB SEP 36-B1 / BB SEP 72-B1
Dimensions (mm)			

MODELS	SEP 700	SEP 1000	SEP 1000 ER	SEP 1500	SEP 2200	SEP 2200 ER	SEP 3000	SEP 3000 ER
<b>POWER</b>	700 VA/630 W	1000 VA/900 W		1500 VA/1350 W	2200 VA/1980 W		3000 VA/2700 W	
<b>INPUT</b>								
Nominal voltage	220-230-240 Vac							
Voltage range without battery intervention	140 Vac < Vin < 276 Vac @50% load / 184 Vac < Vin < 276 Vac @ 100% load							
Voltage tolerance	230 Vac ± 20%							
Maximum permitted voltage	300 Vac							
Nominal frequency	50/60 Hz							
Frequency range	50 Hz ± 5% / 60 Hz ± 5%							
Power factor	> 0.99							
Current distortion	≤7%							
<b>BYPASS</b>								
Voltage tolerance	180 - 264 Vac							
Frequency tolerance	Frequency selected (from ±1.5Hz to ±5Hz configurable)							
Overload Times	125% for 5 seconds, 150% for 1 second							
<b>OUTPUT</b>								
Voltage distortion with linear load / with non-linear load	< 2% / < 4%							
Frequency	Selectable: 50 Hz or 60 Hz or self-learning							
Static variation	± 1%							
Dynamic variation	≤ 5% in 20 msec.							
Waveform	Sinusoidal							
Current crest factor	3 : 1							
Efficiency ECO and Smart Active Modes	98%							
<b>BATTERIES</b>								
Type	VRLA AGM maintenance-free lead based; Supercaps							
Recharge time	2-4 hours	N.A.		2-4 hours	N.A.		2-4 hours	N.A.
<b>OTHER FEATURES</b>								
Net weight (kg)	10.9	13.3	7	14.8	25.6	14	28	15
Gross weight (kg)	12.5	14.9	8.6	15.5	28.8	17	31.2	18
Dimensions (WxDxH) (mm)	158 x 422 x 235				190 x 446 x 333			
Packaging dimensions (WxDxH) (mm)	245 x 500 x 340				325 x 585 x 470			
Protection against overvoltage	300 joules							
Protections	Overcurrent - short-circuit - overvoltage - undervoltage - temperature - excessive low battery							
Communications	USB / DB9 with RS232 and contacts / Slot for communications interface							
Input plugs	1 IEC 320 C14				1 IEC 320 C20			
Output sockets	4 IEC 320 C13				8 IEC 320 C13		8 IEC 320 C13 + 1 IEC 320 C19	
Standards	Safety: EN 62040-1 and Directive 2006/95/EL; EMC: EN 620040-2 and Directives 2004/108/EL							
Operating temperature	0 °C / +40 °C							
Relative humidity	< 95% non-condensing							
Colour	Black							
Noise level at 1 m (ECO Mode)	< 40 dBA							
Standard equipment provided	Power cable, IEC-IEC cable, USB cable, safety manual, quick start guide							

# Sentinel Dual

## 1-3 kVA



SOHO



DATACENTRE



E-MEDICAL



INDUSTRY



TRANSPORT



EMERGENCY



ONLINE



TowerRack



**1:1** 1-3 kVA



USB plug



Hot swap battery



Energy share



Plug & Play installation

### HIGHLIGHTS

- Power factor 0.9
- Simplified installation
- Installation versatility
- Reduced running costs
- Runtime expandability
- Low noise level

Sentinel Dual is the new range of high density double conversion online UPS, suitable for powering a wide range of devices such as servers, storage systems, telephony - VoIP equipment, network and medical systems as well as industrial applications.

It is also ideal for powering and protecting Blade Server systems with high input power factor. At only 2U, Sentinel Dual is ideal for 19" rack cabinet installations.

Sentinel Dual has a practical, modern design and includes several performance advantages over traditional on-line UPS. All developed by the Riello UPS research

and development team. The newly-designed inverter is one of the best energy conversion systems on the market, with a 0.9 output power factor and 92% operating efficiency in on-line mode.

For business continuity applications requiring long battery runtimes, battery autonomy can be extended up to several hours using ER models fitted with more powerful battery chargers.

With energy savings in mind, Sentinel Dual is also fitted with a shut-off button to reduce energy consumption to zero during prolonged periods of inactivity.



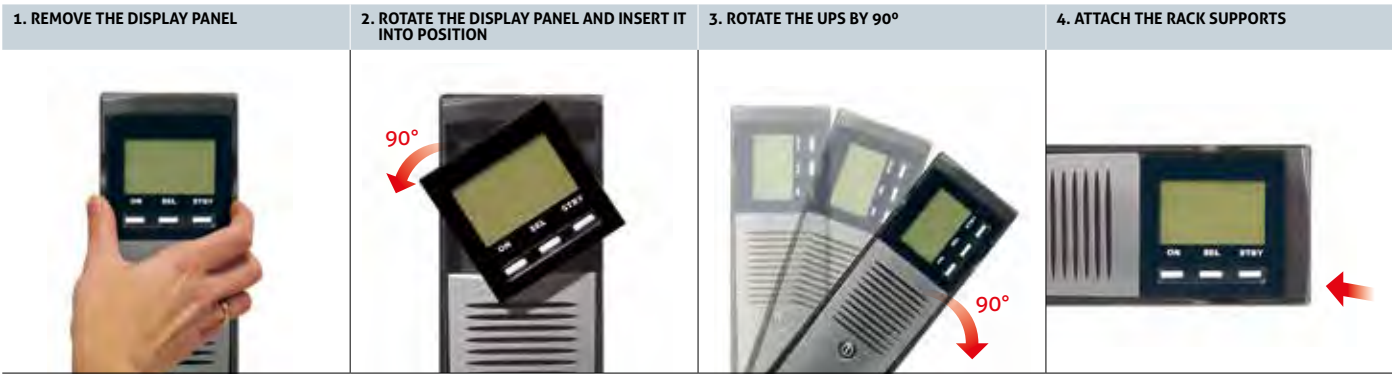

## Simplified installation

- Sentinel Dual can be installed as a tower or in 19" rack cabinets, by simply removing and rotating the display panel
- Low noise (<40 dBA): can be installed in any environment thanks to its high frequency switching inverter and PWM load-dependent digitally controlled fan.
- Operation guaranteed up to 40°C (the components are designed for high temperatures and are thus subject to less stress at normal temperatures)
- On Sentinel Dual models, the output sockets can be programmed to disconnect less critical loads during blackouts (EnergyShare function).

## Installation versatility

Sentinel Dual can be used in a tower or rack format, by simply turning the display and adding the supplied handles or optional runners.

## Reduced running costs

The UPS is highly flexible and easy to configure. Programmable functions can be set via software or manually via the front display panel. Sentinel Dual can be configured in the following operating modes:

- **On Line:** maximum load protection and output voltage waveform quality
- **ECO Mode:** to increase efficiency (up to 98%); allows you to select Line Interactive technology
- **Smart Active:** the UPS automatically decides the operating mode based on the mains power quality
- **Emergency:** the UPS can be selected to function only when the mains power supply fails (emergency only mode)
- **Frequency converter:** operation (50 or 60 Hz).

## Advanced communications

Sentinel Dual offers maximum flexibility for integration with all types of communication systems.

- Multi-platform communication for all operating systems and network environments: PowerShield<sup>3</sup> supervision and shutdown software for Windows operating systems 10, 8, 7, Hyper-V, 2016, 2012, and previous versions, Mac OS X, Linux, VMWare ESXi, Citrix XenServer and other Unix operating systems.
- UPS Tools configuration and customisation software supplied as standard
- RS232 serial port and opto-isolated contacts
- USB port
- Slot for communications boards such as Modbus/Jbus, TCP/IP-SNMP and relay contacts.

## Emergency function

This configuration ensures the operation of emergency systems that must be supplied in the event of a mains power failure, such as emergency lighting, fire detection/ extinguishing systems and alarms.

When the mains power supply fails, the inverter begins powering the loads with a progressive start-up (Soft Start) in order to prevent overload.

Sentinel Dual is compliant for installation in medium-voltage transformer rooms in accordance with applicable legislation, for the power supply with reserve charge of medium-voltage coils.

## High quality output voltage

- Even with non-linear loads (IT loads with a crest factor of up to 3:1)
- High short circuit current on bypass
- High overload capacity: 150% by inverter (even with mains failure)
- Filtered, stabilised and reliable voltage (On-line double conversion technology (VFI compliant with EN62040-2) with filters for the suppression of atmospheric disturbances
- Power factor correction: UPS input power factor close to 1 and sinusoidal current uptake.

## High battery reliability

- Automatic and manual battery test
- Batteries are user replaceable without switching off equipment and without interruption to the load (Hot Swap)
- Unlimited extendible runtime using matching battery boxes.

## Low noise level

Thanks to the use of high frequency components and load-based fan speed control, the noise produced by the UPS is less than 40 dB.

## Other features

- Output voltage can be selected via software (220-230-240 V)
- Auto-restart when mains power is restored (programmable via software)
- Stand-by on bypass: when the machine is switched off, it automatically goes into bypass and battery charge mode
- Minimum load switch-off
- Battery discharge warning
- Start-up delay
- Total microprocessor control
- Automatic bypass without interruption
- Status, measurements and alarms available on standard backlit display
- UPS firmware updating via PC
- Input protection via resettable thermal switch (versions up to 1500 VA)
- Back-feed protection standard: to prevent energy from being fed back to the network
- Manual switching to bypass.

## 2-YEAR WARRANTY

## DETAILS

### SDH 1000

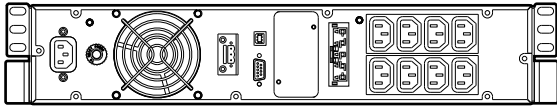

### SDH 1500

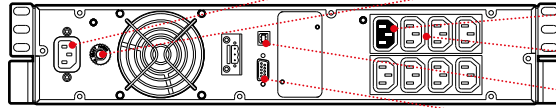

### BBX

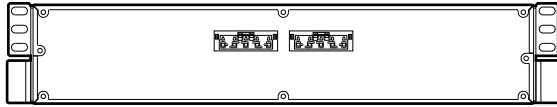

### SDH 2200/2200ER 3000/3000 ER

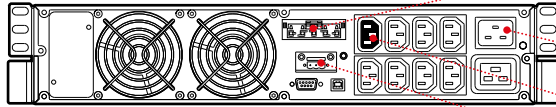

- INPUT SOCKET
- INPUT THERMAL PROTECTION
- ENERGY SHARE
- OUTPUT SOCKETS
- USB PORT
- RS232 SERIAL
- BATTERY EXPANSION SOCKET
- INPUT PLUG
- ENERGY SHARE
- EMERGENCY SWITCH DEVICE (ESD)

## OPTIONS

### SOFTWARE

PowerShield<sup>3</sup>  
PowerNetGuard

### ACCESSORIES

NETMAN 204  
MULTICOM 302  
MULTICOM 352  
MULTICOM 372

MULTICOM 384

MULTI I/O

MULTIPANEL

Manual Bypass 16 A

Manual Bypass 16 A Rack

Automatic Bypass 16 A

Automatic Bypass 16 A Rack

### PRODUCT ACCESSORIES

Universal rails for installation in rack cabinets

## BATTERY BOX

### MODELS

BB SDH 36-A3 / BB SDH 36-M1

BB SDH 72-A3 / BB SDH 72-M1

Dimensions  
(mm)

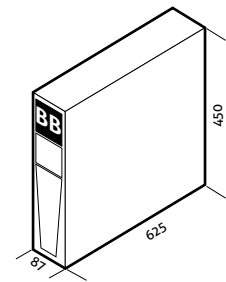
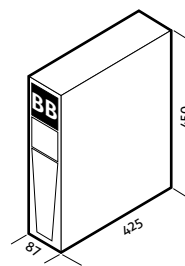

MODELS	SDH 1000	SDH 1500	SDH 2200	SDH 2200 ER	SDH 3000	SDH 3000 ER
<b>POWER</b>	<b>1000 VA/900 W</b>	<b>1500 VA/1350 W</b>	<b>2200VA/1980 W</b>	<b>2200VA/1760 W</b>	<b>3000 VA/2700 W</b>	<b>3000 VA/2400 W</b>
<b>INPUT</b>						
Nominal voltage	220-230-240 Vac					
Voltage range without battery intervention	140 Vac < Vin < 276 Vac @50% load / 184 Vac < Vin < 276 Vac @ 100% load					
Voltage tolerance	230 Vac ± 20%					
Maximum permitted voltage	300 V					
Nominal frequency	50/60 Hz ±5Hz					
Frequency range	50 Hz ± 5% / 60 Hz ± 5%					
Power factor	> 0.98					
Current distortion	≤7%					
<b>BYPASS</b>						
Voltage tolerance	200 - 253 Vac					
Frequency tolerance	Frequency selected (from ±0.5Hz to ±5Hz configurable)					
Overload Times	125% for 4 seconds, 150% for 0.5 seconds					
<b>OUTPUT</b>						
Voltage distortion with linear load / with non-linear load	< 2% / ≤3.5%					
Frequency	Selectable: 50 Hz or 60 Hz or self-learning					
Static variation	± 1%					
Dynamic variation	≤ 5% in 20 msec.					
Waveform	Sinusoidal					
Current crest factor	3 : 1					
Efficiency ECO and Smart Active Modes	98%					
<b>BATTERIES</b>						
Type	VRLA AGM maintenance-free lead based					
Recharge time	2-4 hours					
<b>OTHER FEATURES</b>						
Net weight (kg)	17.5	18	30.5	15	31	15
Gross weight (kg)	21	21.5	35	19.5	35.5	19.5
Dimensions (WxDxH) (mm)	(T- 87 x 425 x 450) (R- 19" x 425 x 2U)			(T- 87 x 625 x 450) (R- 19" x 625 x 2U)		
Packaged dimensions (WxDxH) (mm)	550 x 600 x 245			600 x 760 x 245		
Protection against overvoltages	300 joules					
Protections	Overcurrent - short-circuit - overvoltage - undervoltage - temperature - excessive low battery					
Communications	USB / DB9 with RS232 and contacts / Slot for communications interface					
Input plugs	1 IEC 320 C14			1 IEC 320 C20		
Output sockets	8 IEC 320 C13			8 IEC 320 C13 + 1 IEC 320 C19		
Standards	Safety: EN 62040-1 and Directive 2006/95/EL; EMC: EN 620040-2 and Directives 2004/108/EL					
Operating temperature	0 °C / +40 °C					
Relative humidity	< 95% non-condensing					
Colour	Black					
Noise level at 1 m (ECO Mode)	< 40 dBA					
Standard equipment provided	Power cable, serial cable, USB cable, safety manual, quick start guide					

# Sentinel Dual

## High Power



SOHO



DATACENTRE



E-MEDICAL



INDUSTRY



TRANSPORT



EMERGENCY



ONLINE



Tower Rack



**1:1** 3.3-4 kVA

**3:1** 6.5-10 kVA



USB plug



Hot swap battery



Energy share

### HIGHLIGHTS

- Simplified installation
- Operating mode selection
- High quality output voltage
- High battery reliability

Sentinel Dual is the best solution for powering mission critical applications and electro-medical devices requiring maximum power reliability.

Flexibility of installation and use (digital display, user-replaceable battery set), as well as the many communication options available, makes Sentinel Dual suitable for many different applications from IT to security.

Sentinel Dual can be installed on the floor or in rack cabinets for networking applications. The Sentinel Dual range is available in 3.3-4 and 6.5-10 kVA models with on-

line double conversion technology (VFI): the load is powered continuously by the inverter which supplies a sinusoidal voltage, filtered and stabilised in terms of voltage, form and frequency. In addition, the input and output filters significantly increase the load's immunity to mains disturbances and lightning strikes.

Technology and performance: selectable Eco Mode and Smart Active Mode functions. Diagnostics: Standard digital display, RS232 and USB interfaces with PowerShield<sup>3</sup> software included, communications slot for connectivity accessories.





### Simplified installation

- Can be installed on the floor (tower version) or in rack mount cabinets (rack version). The display panel can be rotated (using the key supplied)
- Low noise (<40 dBA): can be installed in any environment thanks to its high frequency switching inverter and PWM load-dependent digitally controlled fan.
- Operation guaranteed up to 40°C (the components are designed for high temperatures and are thus subject to less stress at normal temperatures)

### Operating mode selection

Functions can be programmed via software or manually via the front display panel.

- **On line**
- **Eco Mode:** to increase efficiency (up to 98%), allows for the selection of Line Interactive technology (VI) to power low priority loads from the mains supply
- **Smart Active:** the UPS automatically decides upon the operating mode (VI or VFI) based on the quality of the mains power supply
- **Emergency:** the UPS can be selected to function only when the mains power supply fails (emergency only mode).
- **Frequency converter** operation (50 or 60 Hz).

### High quality output voltage

- Even with non-linear loads (IT loads with a crest factor of up to 3:1)
- High short circuit current on bypass
- High overload capacity: 150% by inverter (even with mains failure)
- Filtered, stabilised and reliable voltage (double conversion on-line technology (VFI compliant with EN62040-3), with filters for the suppression of atmospheric disturbances.
- Power factor correction: UPS input power factor close to 1 and sinusoidal current uptake.

### High battery reliability

- Automatic and manual battery test
- Reduced ripple component (detrimental to the batteries) using a low ripple current discharge (LCRD) system
- Batteries are user replaceable without switching off equipment and without interruption to the load (Hot Swap)
- Unlimited extendible runtime using matching Battery Boxes
- The batteries do not cut in during mains failures of <40 ms (high hold up time) or when the input supply is between 84 V to 276 V.

### Emergency function

This configuration ensures the operation of those emergency systems that require continuous, reliable and long-lasting power supply in the event of a mains power failure, such as emergency lighting, fire detection/ extinguishing systems and alarms. When the mains power supply fails, the inverter begins powering the loads with a progressive start-up (Soft Start) in order to prevent overload.

### Battery optimisation

The wide input voltage range and a high hold-up time minimise battery usage and increase efficiency and battery life; for smaller power breaks, energy is drawn from a group of appropriately-sized capacitors.

### Other features

- Selectable output voltage (220-230-240 V)
- Auto-restart when mains power is restored (programmable via software)
- Bypass on: when the machine is switched off, it automatically goes into bypass and battery charge mode
- Minimum load switch-off
- Low battery warning
- Start-up delay
- Total microprocessor control
- Automatic bypass without interruption
- Use of IMS modules (Insulated Metallic Substrates)
- Status, measurements and alarms available on standard backlit display

- UPS digital updating (flash upgradeable)
- Input protection via resettable thermal switch
- Back-feed protection standard: to prevent energy from being fed back to the network
- Manual switching to bypass.

### Advanced communications

- Advanced multi-platform communications for all operating systems and network environments: PowerShield<sup>3</sup> monitoring and shutdown software for Windows operating systems 8, 7, Hyper-V, 2012, 2008, and previous versions, Mac OS X, Linux, VMWare ESXi, Citrix XenServer and other Unix operating systems
- Plug and play function
- USB port
- RS232 serial port
- Slot for installation of communications boards.

### High Power Factor

- More power delivered
- More real output power (W)

### 2-YEAR WARRANTY

## BATTERY BOX

MODELS	BB SDL 108-A4 / BB SDL 108-M1	BC SDL 108-B1
Dimensions (mm)		

## DETAILS

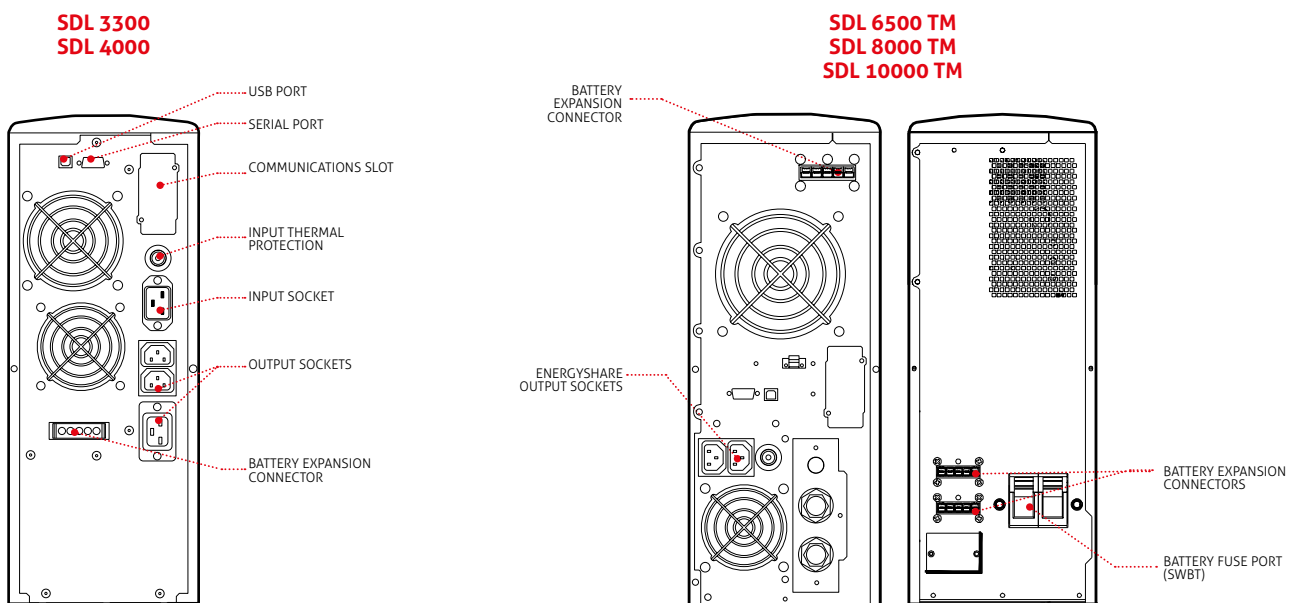

## OPTIONS

### SOFTWARE

PowerShield<sup>3</sup>  
PowerNetGuard

### ACCESSORIES

NETMAN 204  
MULTICOM 302  
MULTICOM 352  
MULTICOM 372  
MULTICOM 384  
MULTI I/O

### MULTIPANEL

Manual Bypass 16 A  
Manual bypass 16 A Rack  
Automatic bypass 16 A  
Automatic bypass 16 A Rack

### PRODUCT ACCESSORIES

Universal rails for installation in rack cabinets

MODELS	SDL 3300	SDL 4000	SDL 6500 TM	SDL 8000 TM	SDL 10000 TM
<b>POWER</b>	<b>3300 VA/2300 W</b>	<b>4000 VA/2400 W</b>	<b>6500 VA/5850 W</b>	<b>8000 VA/7200 W</b>	<b>10000 VA/9000 W</b>
<b>INPUT</b>					
Nominal voltage	220-230-240 Vac		400 Vac three-phase + N		
Voltage tolerance	230 Vac ± 20%		400 Vac ± 20%		
Minimum voltage	184 Vac @ 100% load / 92 Vac @ 50% load				
Nominal frequency	50/60 Hz ± 5 Hz				
Power factor	> 0.98		> 0.95		
<b>BYPASS</b>					
Voltage tolerance	180 - 264 Vac (selectable in Eco Mode or Smart Active Mode)				
Frequency tolerance	Selected frequency ±5%				
Overload Times	125% for 4 seconds, 150% for 0,5 seconds				
<b>OUTPUT</b>					
Nominal voltage	220-230-240 Vac selectable				
Voltage distortion	< 3% with linear load / < 6% with non-linear load				
Frequency	50/60 Hz selectable				
Static variation	1.5%				
Dynamic variation	≤ 5% in 20 ms				
Waveform	Sinusoidal				
Crest factor	3 : 1				
<b>BATTERIES</b>					
Type	VRLA AGM maintenance-free lead based				
Recharge time	4-6 hours				
<b>OTHER FEATURES</b>					
Net weight (kg)	38	40	91	94	95
Gross weight (kg)	42.5	44.5	99	102	103
Dimensions (WxDxH) (mm)	175 x 520 x 455 tower 19" x 520 x 4U rack		2 x (175 x 660 x 455) tower / 2 x (19" x 660 x 4U) rack		
Packaged dimensions (WxDxH) (mm)	540 x 620 x 280		780 x 555 x (270+15)		
Efficiency Line-interactive/Smart Active	98%				
Protections	Overcurrent - short-circuit - overvoltage - undervoltage - temperature - excessive low battery				
Communications	USB / RS232 + slot for communications interface				
Input plugs	1 IEC 320 C20		Terminal board		
Output sockets	2 IEC 320 C13 + 1 IEC 320 C20		Terminal board + 2 IEC 320 C13		
Standards	EN 62040-1 EMC EN 62040-2 Directives 73/23 - 93/68 - 2004/108 EC EN 62040-3				
Operating temperature	0 °C / +40 °C				
Relative humidity	< 95% non-condensing				
Colour	Dark grey RAL 7016				
Noise level at 1 m (ECO Mode)	< 40 dBA		< 45 dBA		
Standard equipment provided	2 10 A cables; 1 IEC-16 A plug; software; serial cable; keys for releasing display panel; handles kit		2 cable guides; cable tips; software; serial cable; keys for releasing display panel; handles kit		

# Sentinel Dual

## 5-10 kVA



SOHO



DATACENTRE



E-MEDICAL



INDUSTRY



TRANSPORT



EMERGENCY



ONLINE



TowerRack



**1:1** 5-10 kVA



USB plug



Hot swap battery



Energy share

### HIGHLIGHTS

- **Power factor 1 kW = kVA**
- **Parallelable up to 3 unit**
- **Simplified installation**
- **Operating mode selection**
- **High quality output voltage**
- **High battery reliability**



Sentinel Dual is the best solution for powering mission critical applications and electro-medical devices requiring maximum power reliability.

Flexibility of installation and use (digital display, user-replaceable battery set), as well as the many communication options available, makes the Sentinel Dual suitable for many different applications from IT to security. Up to 3 Sentinel Duals can be operated in parallel in either capacity or N+1 redundant configuration offering increased reliability for critical system. The Sentinel Dual can be installed as Tower (floor standing) or Rack, ideal for network and server rack applications.

The Sentinel Dual range is available in 5-6-8-10 kVA/kW models with on-line double conversion technology (VFI): the

load is powered continuously by the inverter which supplies a sinusoidal voltage, filtered and stabilised in terms of voltage, form and frequency. In addition, the input and output filters significantly increase the load's immunity to mains disturbances and lightning strikes.

Technology and performance: selectable Eco Mode and Smart Active Mode functions. Diagnostics: Standard digital display, RS232 and USB interfaces with PowerShield<sup>3</sup> software downloadable, communications slot for connectivity accessories.

#### Simplified installation

- Can be installed on the floor (tower version) or in rack mount cabinets (rack version). The display panel can be rotated (using the key supplied)



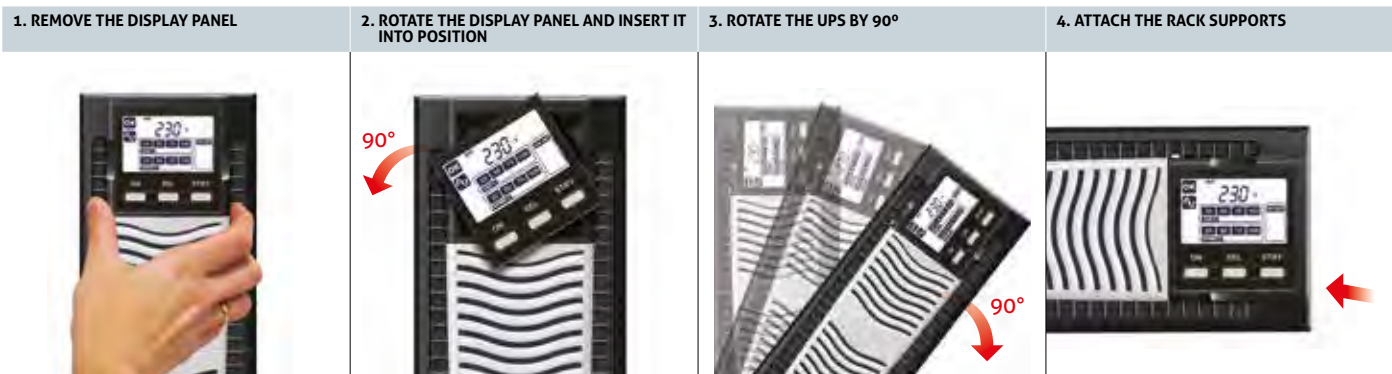

- Low noise (<45 dBA); can be installed in any environment thanks to its high frequency switching inverter and PWM load-dependent digitally controlled fan
- External bypass option for maintenance with interruption-free switching
- Operation guaranteed up to 40°C (the components are designed for high temperatures and are thus subject to less stress at normal temperatures)
- Built-in IEC output sockets with thermal protection.

### Operating mode selection

Functions can be programmed via software or manually via the front display panel.

- **On line:** efficiency up to 95%
- **Eco Mode:** to increase efficiency (up to 98%), allows for the selection of Line Interactive technology (VI) to power low priority loads from the mains supply
- **Smart Active:** the UPS automatically decides upon the operating mode (VI or VFI) based on the quality of the mains power supply
- **Emergency:** the UPS can be selected to function only when the mains power supply fails (emergency only mode).
- **Frequency converter** operation (50 or 60 Hz).

### High quality output voltage

- Even with non-linear loads (IT loads with a crest factor of up to 3:1)
- High short circuit current on bypass
- High overload capacity: 150% by inverter (even with mains failure)
- Filtered, stabilised and reliable voltage (double conversion on-line technology (VFI compliant with EN62040-3), with filters for the suppression of atmospheric disturbances.
- Power factor correction: UPS input power factor close to 1 and sinusoidal current uptake.

### High battery reliability

- Automatic and manual battery test
- Reduced ripple component (detrimental to the batteries) using a low ripple current discharge (LCRD) system
- Batteries are user replaceable without switching off equipment and without interruption to the load (Hot Swap)
- Unlimited extendible runtime using matching Battery Boxes
- The batteries do not cut in during mains failures of <20 ms (high hold up time) or when the input supply is between 184 V to 276 V.

### Emergency function

This configuration ensures the operation of those emergency systems that require continuous, reliable and long-lasting power supply in the event of a mains power failure, such as emergency lighting, fire detection/ extinguishing systems and alarms. When the mains power supply fails, the inverter begins powering the loads with a progressive start-up (Soft Start) in order to prevent overload.

### Battery optimisation

The wide input voltage range and a high hold-up time minimise battery usage and increase efficiency and battery life; for smaller power breaks, energy is drawn from a group of appropriately-sized capacitors.

### EnergyShare

10 A configurable IEC output sockets allow for runtime optimisation by programming the switching off of low priority loads on mains failure; alternatively, emergency loads that are normally not powered when mains is present can be activated.

### Other features

- Selectable output voltage (220-230-240 V)
- Dual input supplies configuration (SDU 10000 DI and SDU 10000 DI ER)
- Auto-restart when mains power is restored (programmable via software)
- Bypass on: when the machine is switched off, it automatically goes into bypass and battery charge mode
- Minimum load switch-off
- Low battery warning
- Start-up delay
- Total microprocessor and DSP control
- Automatic bypass without interruption
- Use of custom power modules
- Status, measurements and alarms available on standard backlit display
- UPS digital updating (flash upgradeable)
- Output sockets protected with resettable thermal switch
- Back-feed protection standard: to prevent energy from being fed back to the network
- Manual switching to bypass.

### Advanced communications

- Advanced multi-platform communications for all operating systems and network environments: PowerShield<sup>3</sup> monitoring and shutdown software for Windows operating systems 10, 8, 7, Hyper-V, 2016, 2012, and previous versions, Mac OS X, Linux, VMWare ESXi, Citrix XenServer and other Unix operating systems
- Plug and play function
- USB port
- RS232 serial port
- Slot for installation of communications boards.

### Unity Power Factor

- More power delivered
- More real output power (W)

### 2-YEAR WARRANTY

## BATTERY BOX

MODELS	MODELS BB SDU 180-A3	BB SDU 240-A3	BB SDU 180-B1/ BB SDU 240-B1
Dimensions (mm)			

## DETAILS

**SDU 5000**  
**SDU 6000**  
**SDU 6000 ER\***

**SDU 8000**  
**SDU 10000**  
**SDU 10000 DI\***

**SDU 10000 DI ER\***

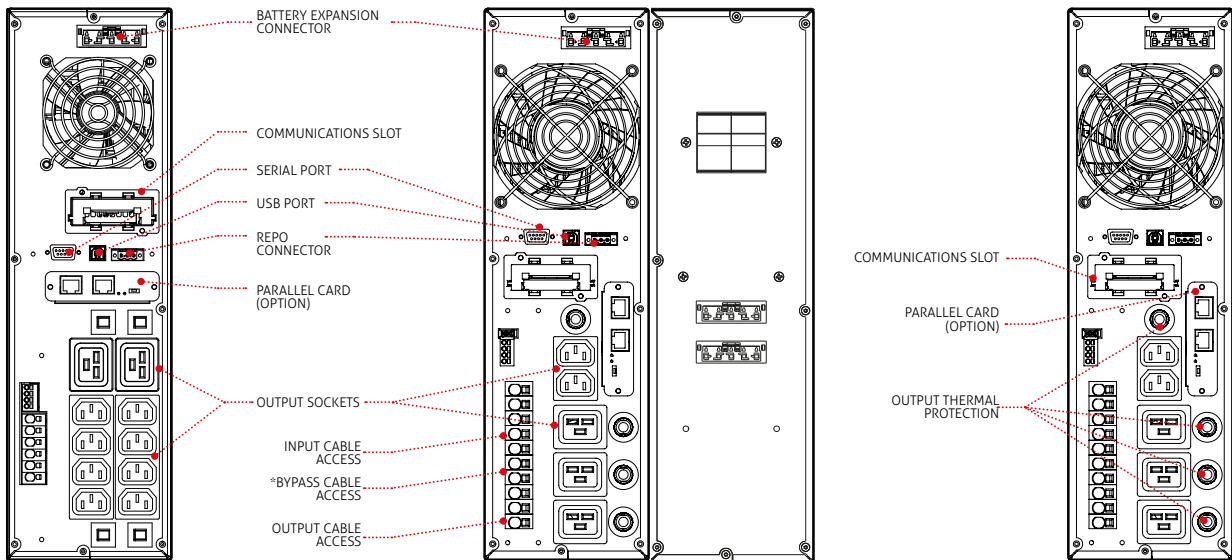

\* DI = DUAL INPUT  
ER = EXTENDED RECHARGE

## OPTIONS

### SOFTWARE

PowerShield<sup>3</sup>  
PowerNetGuard

### ACCESSORIES

NETMAN 204  
MULTICOM 302  
MULTICOM 352  
MULTICOM 372  
MULTICOM 384  
MULTI I/O  
MULTIPANEL

### PRODUCT ACCESSORIES

Universal rails for installation in rack cabinets  
Parallel card  
Distribution Box

MODELS	SDU 5000	SDU 6000	SDU 6000 ER	SDU 8000	SDU 10000	SDU 10000 DI	SDU 10000 DI ER
<b>INPUT</b>							
Dual Input	no					yes	
Nominal voltage	220-230-240 Vac						
Voltage tolerance	230 Vac $\pm$ 20%						
Minimum voltage	184 Vac						
Nominal frequency	50/60 Hz $\pm$ 5Hz						
Power factor	> 0.98						
Current distortion	$\leq$ 5%						
<b>BYPASS</b>							
Voltage tolerance	180 - 264 Vac (selectable in Economy Mode or Smart Active Mode)						
Frequency tolerance	Selected frequency $\pm$ 5% (selectable by user)						
Overload Times	< 110% continuous, 130% for 1 hour, 150% for 10 minutes, over 150% for 3 seconds						
<b>OUTPUT</b>							
Nominal power (VA)	5000	6000	6000	8000	10000	10000	10000
Active power (W)	5000	6000	6000	8000	10000	10000	10000
Nominal voltage	220-230-240 Vac selectable						
Voltage distortion	< 3% with linear load / < 6% with non-linear load						
Frequency	50/60 Hz selectable						
Static variation	1.5%						
Dynamic variation	$\leq$ 5% in 20 ms						
Waveform	Sinusoidal						
Crest factor	3 : 1						
<b>BATTERIES</b>							
Type	VRLA AGM maintenance-free lead based						
Recharge time	4-6 hours						
<b>OTHER FEATURES</b>							
Net weight (kg)	46	47	19	21+60	22+65	22+65	23
Gross weight (kg)	52	53	25	27+66	28+71	28+71	29
Dimensions (WxDxH) (mm)	131 x 640 x 448 tower 19" x 640 x 3U rack			2 x (131 x 640 x 448) tower - 2 x (19" x 640 x 3U) rack ER version (131 x 640 x 448) tower - (19" x 640 x 3U) rack			
Packaged dimensions (WxDxH) (mm)	780 x 555 x (270+15)			2 x (780 x 555 x 270) + H 15 ER version (780 x 555 x (270+15))			
Efficiency	up to 95% on line mode, 98% eco mode						
Protections	Overcurrent - short-circuit - overvoltage - undervoltage - temperature - excessive low battery						
Parallel Operation	Optional Parallel Card						
Communications	USB / RS232 / slot for communications interface / REPO + Input contact						
Input Connection	Terminal block						
Output sockets	Terminal block + 8 IEC 320 C13 + 2 IEC 320 C20			Terminal block + 2 IEC 320 C13 + 3 IEC 320 C20			
Standards	EN 62040-1 EMC EN 62040-2 Directives 73/23 - 93/68 - 2004/108 EC EN 62040-3						
Operating temperature	0 °C / +40 °C						
Relative humidity	< 95% non-condensing						
Colour	Black RAL 9005						
Noise level at 1 m (ECO Mode)	< 48 dBA						
Standard equipment provided	USB cable; handles kit						

# Sentinel Power Green



SOHO



DATACENTRE



E-MEDICAL



INDUSTRY



TRANSPORT



EMERGENCY



ONLINE



Tower



**1:1** 6 kVA

**1:1** **3:1** 8-20 kVA



USB plug



Energy share



Service 1st start

## HIGHLIGHTS

- Small footprint
- Power factor 0.9
- High efficiency 97%
- Parallelable 2+1
- Simplified installation
- High quality output voltage

Sentinel Power Green is the ideal solution for protecting IT systems, telecommunications equipment and mission critical systems such as safety devices, ensuring maximum power reliability. Sentinel Power Green is designed and built using state-of-the-art technology and components to provide maximum protection to the powered loads with no impact on downstream systems and optimised energy savings.

The series includes 6 kVA single/single-phase and 8-20 kVA single/single-phase and three/single-phase models with on-line double conversion technology (VFI):

the load is powered continuously by the inverter which supplies a sinusoidal voltage, filtered and stabilised in terms of form and frequency.

Input and output filters provide significant further immunity from mains disturbances and lightning strikes.

In terms of technology and performance, Sentinel Power Green is one of the best UPS available on the market today: selectable Eco Mode and Smart Active Mode functions; custom diagnostics LCD display, RS232 and USB interfaces with Powershield<sup>3</sup> software, ESD input, interface slot with optional boards.



## High UPS reliability

- Total microprocessor control.
- Interruption-free static and manual bypass.
- Specifications guaranteed up to 40°C (the components are designed to work at high temperatures and thus are subject to less stress at normal temperatures).

## Parallelable

Parallel configuration of 3 units for (2+1) redundant or power parallel system. The UPS continue to operate in parallel even if the connection cable is interrupted (Closed Loop).

## Operating mode selection

The operating mode can be programmed via software or manually via the front display panel.

- **On line:** double conversion Mode: for critical applications.
- **Eco Mode:** to increase efficiency (up to 98%), allows for the selection of Line Interactive technology (VI) to power low priority loads from the mains supply.
- **Smart Active:** the UPS automatically decides upon the operating mode (VI or VFI) based on the quality of the mains power supply.
- **Emergency:** the UPS can be selected to function only when the mains power supply fails (emergency only mode).
- **Frequency converter** operation (50 or 60 Hz).

## High quality output voltage

- Even with non-linear loads (IT loads with a crest factor of up to 3:1).
- High short circuit current on bypass.
- High overload capacity: 150% by inverter (even with mains failure).
- Filtered, stabilised and reliable voltage (double conversion on-line technology - VFI compliant with EN62040-3), with filters for the suppression of atmospheric disturbances.
- Power factor correction: UPS input power factor close to 1 and sinusoidal current uptake.

## Simplified installation

- UPS can be installed on a single-phase or three-phase distribution network.
- Output terminal board + 2 IEC sockets for powering local consumers (computers, modems, etc.).
- Simplified positioning (built-in castors).

## High battery reliability

- Automatic and manual battery test.
- Proper battery care is critical to ensuring



correct UPS operation in emergency conditions. The Riello UPS battery care system consists of a series of features and capabilities to optimise battery management and obtain the best performance and operating life possible.

- Unlimited extendible runtime using matching Battery Boxes.
- The batteries do not cut in during mains failures of <40 ms (high hold up time) or when the input supply is between 84 V to 276 V.

## Low impact on the mains

Sinusoidal uptake of input current on single-phase/single-phase series.

## Other features

- Advanced diagnostics: status, measurements and alarms available on custom LCD display.
- Low noise (<40 dBA): can be installed in any environment thanks to its high frequency switching inverter and PWM load-dependent digitally controlled fan (>20 kHz, value above audible range).

- Auto restart (automatic when mains supply is restored, programmable via software or display panel).
- Emergency function: the UPS can be selected to function only when the mains power supply fails (emergency lights).
- Back-feed protection standard: to prevent energy from being fed back to the network.
- UPS digital updating (flash upgradeable).

## Advanced communications

- Compatible with Riello UPS TeleNetGuard remote monitoring.
- Advanced multi-platform communications for all operating systems and network environments: PowerShield<sup>3</sup> monitoring and shutdown software for Windows operating systems 10, 8, 7, Hyper-V, 2016, 2012, and previous versions, Mac OS X, Linux, VMWare ESXi, Citrix XenServer and other Unix operating systems.
- RS232 serial and USB ports.
- Plug and play function.
- Slot for installation of communications boards.



## OPTIONS

### SOFTWARE

PowerShield<sup>3</sup>  
PowerNetGuard

### ACCESSORIES

NETMAN 204  
MULTICOM 302  
MULTICOM 352  
MULTICOM 372  
MULTICOM 384  
MULTI I/O  
MULTIPANEL  
Manual Bypass MBB 100 A

### PRODUCT ACCESSORIES

Isolation transformer module (hlp)  
mm/kg: 500 x 400 x 265 / 80  
(only for 5000-6000 VA models)

## DETAILS

### SPM 6 - SPH 8 - SPH 10 SPH 10 ER\*

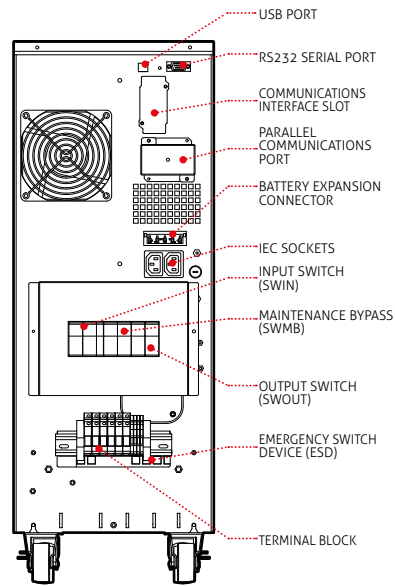

### SPH 15 - SPH 20 - SPH 20 ER\*

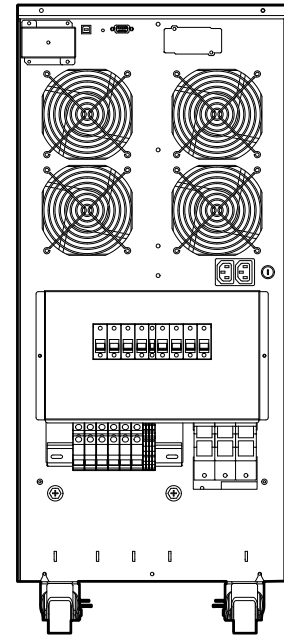

\*ER = EXTENDED RECHARGE

## BATTERY BOX

MODELS	BB SPM 180-A3 / BB SPM 180-M1 BB SPH 240-A3 / BB SPH 240 M1	BB MST 1320 480
Dimensions (mm)		

MODELS	SPM 6	SPH 8	SPH 10	SPH 10 ER	SPH 15	SPH 20	SPH 20 ER	
<b>POWER</b>	6000 VA/ 5400 W	8000 VA/ 7200 W	10000 VA/ 9000 W	10000 VA/ 9000 W	15000 VA/ 13500 W	20000 VA/ 18000 W	20000 VA/ 18000 W	
<b>INPUT</b>								
Nominal voltage	220-230-240 Vac 1 ph	220-230-240 Vac 1 ph / 380-400-415 Vac 3 ph + N						
Voltage tolerance	230 Vac ± 20%	230 Vac ± 20% / 400 Vac ± 20%						
Minimum voltage without battery intervention	176 Vac @ 100% load / 110 Vac @ 50% load							
Maximum operating voltage	276 Vac							
Nominal frequency	50/60 Hz ±10 Hz							
<b>BYPASS</b>								
Voltage tolerance	160 - 276 Vac (selectable in Eco Mode or Smart Active Mode)							
Frequency tolerance	Selected frequency ±10%							
Overload Times	125% for 1 minute, 150% for 10 seconds							
<b>OUTPUT</b>								
Nominal voltage	220-230-240 Vac selectable							
Voltage distortion	< 2% with linear load / < 5% with non-linear load							
Current distortion	3%							
Frequency	50/60 Hz selectable or with automatic selection							
Static variation	± 1.5 %							
Dynamic variation	≤ 5% in 20 ms							
Waveform	Sinusoidal							
Crest factor	≥ 3 : 1							
<b>BATTERIES</b>								
Type	VRLA AGM maintenance-free lead based							
Recharge time	6-8 hours							
Recharge current (only for ER versions)	n.a.		4.4 A		n.a.		5 A	
<b>OTHER FEATURES</b>								
Net weight (kg)	63	78	84	28	146	157	48	
Gross weight (kg)	77	92	98	42	164	175	66	
Dimensions (WxDxH) (mm)	262 x 654 x 708				350 x 731 x 818			
Packaged dimensions (WxDxH) (mm)	720 x 428 x 970				870 x 475 x 1075			
Smart Active efficiency	up to 98%							
Protections	Overcurrent - short-circuit - overvoltage - undervoltage - temperature - excessive low battery							
Communications	USB / RS232 + slot for communications interface							
Parallel	max. 2 units in parallel with optional kit							
Input plugs	Terminal block							
Output sockets	Terminal block + 2 IEC 320 C13							
Standards	EN 62040-1 EMC EN 62040-2 Directives 2006/95/EC - 2004/108 EC EN 62040-3							
Operating temperature	0 °C / +40 °C							
Relative humidity	< 95% non-condensing							
Colour	Dark grey RAL 7016							
Noise level at 1 m (ECO Mode)	< 40 dBA							
Moving the UPS	castors							

# Sentinel Power



SOHO



DATACENTRE



E-MEDICAL



INDUSTRY



TRANSPORT



EMERGENCY



ONLINE



Tower



**1:1** 5-6 kVA

**1:1** **3:1** 6.5-10 kVA



USB plug



Supercaps UPS



Energy share



Service 1st start



## HIGHLIGHTS

- High UPS reliability
- Operating mode selection
- High quality output voltage
- Simplified installation
- High battery reliability
- Low impact on the mains

Sentinel Power is the ideal solution for powering sensitive, mission critical systems such as safety devices (electro-medical devices), ensuring maximum power reliability.

The series includes 5-6 kVA single/single-phase and 6.5-8-10 kVA single/single-phase and three/single-phase models with on-line double conversion technology (VFI): the load is powered continuously by the inverter which supplies a sinusoidal voltage, filtered

and stabilised in terms of voltage, form and frequency. Input and output filters provide significant further immunity from mains disturbances and lightning strikes. In terms of technology, performance (selectable Eco and Smart Active Modes) and diagnostics (LCD custom display, RS232 and USB interfaces with Powershield<sup>3</sup> software included, ESD input, interface slot for optional boards), Sentinel Power is one of the best UPS available on the market.



## High UPS reliability

- Total microprocessor control.
- Interruption-free static and manual bypass.
- Specifications guaranteed up to 40°C (the components are designed to work at high temperatures and thus are subject to less stress at normal temperatures).

## Operating mode selection

The operating mode can be programmed via software or manually via the front display panel.

- **On line.**
- **Eco Mode:** to increase efficiency (up to 98%), allows for the selection of Line Interactive technology (VI) to power low priority loads from the mains supply.
- **Smart Active:** the UPS automatically decides upon the operating mode (VI or VFI) based on the quality of the mains power supply.
- **Emergency:** the UPS can be selected to function only when the mains power supply fails (emergency only mode).
- **Frequency converter** operation (50 or 60 Hz).

## High quality output voltage

- Even with non-linear loads (IT loads with a crest factor of up to 3:1).
- High short circuit current on bypass.
- High overload capacity: 150% by inverter (even with mains failure).
- Filtered, stabilised and reliable voltage (double conversion on-line technology - VFI compliant with EN62040-3), with filters for the suppression of atmospheric disturbances.
- Power factor correction: UPS input power factor close to 1 and sinusoidal current uptake.

## Simplified installation

- UPS can be installed on a single-phase or three-phase distribution network
- Output terminal board + 2 IEC sockets for powering local consumers (computers, modems, etc.)
- Simplified positioning (built-in castors).

## High battery reliability

- Automatic and manual battery test
- Reduced ripple component (detrimental to the batteries) using a low ripple current discharge (LCRD) system
- Unlimited extendible runtime using matching Battery Boxes
- The batteries do not cut in during mains failures of <40 ms (high hold up time) or when the input supply is between 84 V to 276 V.

## Energy-share

Two 10 A configurable IEC output sockets allow for runtime optimisation by programming the switching off of low priority loads on mains failure; alternatively, emergency loads that are normally not powered when mains is present can be activated.

## Low impact on the mains

Sinusoidal uptake of input current on single-phase/single-phase series.

## Other features

- Advanced diagnostics: status, measurements and alarms available on custom LCD display
- Low noise (<40 dBA): can be installed in any environment thanks to its high frequency switching inverter and PWM load-dependent digitally controlled fan (>20 kHz, value above audible range)
- Auto restart (automatic when mains supply is restored, programmable via software or display panel)
- Emergency function: the UPS can be selected to function only when the mains power supply fails (emergency lights)
- Back-feed protection standard: to prevent energy from being fed back to the network
- UPS digital updating (flash upgradeable).



## Advanced communications

- Compatible with Riello UPS TeleNetGuard remote monitoring
- Advanced multi-platform communications for all operating systems and network environments: PowerShield<sup>3</sup> monitoring and shutdown software for Windows operating systems 10, 8, 7, Hyper-V, 2016, 2012, and previous versions, Mac OS X, Linux, VMWare ESXi, Citrix XenServer and other Unix operating systems
- RS232 serial port
- Plug and play function
- Slot for installation of communications boards.



## BATTERY BOX

### MODELS

BB SPW 240-A3 / BB SPW 240-A6  
BC SPW 240-M1/ BC SPW 240-M4

Dimensions  
(mm)

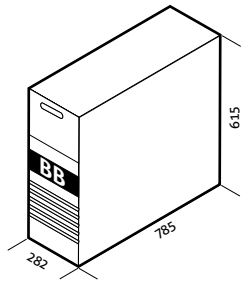

## OPTIONS

### SOFTWARE

PowerShield<sup>3</sup>  
PowerNetGuard

### ACCESSORIES

NETMAN 204  
MULTICOM 302  
MULTICOM 352  
MULTICOM 372  
MULTICOM 384  
MULTI I/O

### MULTIPANEL

Manual Bypass MBB 100 A

### PRODUCT ACCESSORIES

Isolation transformer module (hlp)  
mm/kg: 500 x 400 x 265 / 80  
(only for 5000-6000 VA models)

## DETAILS

### SPW 5000 - SPW 6000 SPT 6500 - SPT 8000 - SPT 10000

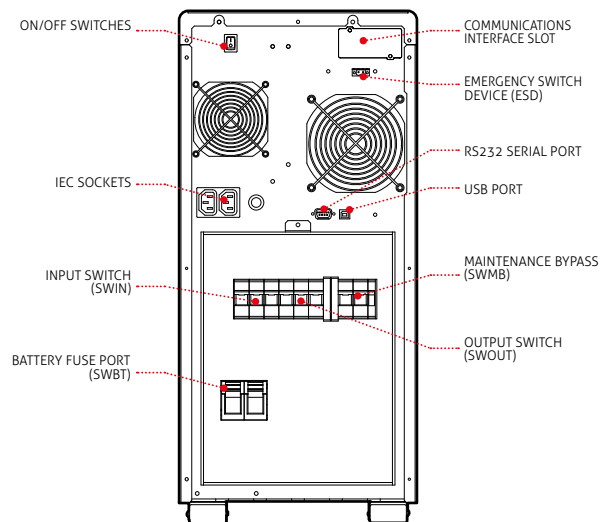

MODELS	SPW 5000	SPW 6000	SPT 6500	SPT 8000	SPT 10000
<b>POWER</b>	<b>5000 VA/4000 W</b>	<b>6000 VA/4800 W</b>	<b>6500 VA/5200 W</b>	<b>8000 VA/6400 W</b>	<b>10000 VA/8000 W</b>
<b>INPUT</b>					
Nominal voltage	220-230-240 Vac single-phase		220-230-240 Vac single-phase or 380-400-415 Vac three-phase + N		
Voltage tolerance	230 Vac $\pm$ 20%		230 Vac $\pm$ 20% / 400 Vac $\pm$ 20%		
Minimum voltage without battery intervention	170 Vac @ 100% load / 140 Vac @ 50% load				
Nominal frequency	50/60 Hz $\pm$ 5 Hz				
<b>BYPASS</b>					
Voltage tolerance	180 - 264 Vac (selectable in Eco Mode or Smart Active Mode)				
Frequency tolerance	Selected frequency $\pm$ 5%				
Overload Times	125% for 4 seconds, 150% for 0.5 seconds				
<b>OUTPUT</b>					
Nominal voltage	220 - 230 - 240 Vac selectable				
Voltage distortion	< 3% with linear load / < 6% with non-linear load				
Frequency	50/60 Hz selectable or with automatic selection				
Static variation	$\pm$ 1.5%				
Dynamic variation	$\leq$ 5% in 20 ms				
Waveform	Sinusoidal				
Crest factor	$\geq$ 3 : 1				
<b>BATTERIES</b>					
Type	VRLA AGM maintenance-free lead based				
Recharge time	6-8 hours				
<b>OTHER FEATURES</b>					
Net weight (kg)	91		92	105	106
Gross weight (kg)	99		100	110	111
Dimensions (WxDxH) (mm)	282 x 785 x 615				
Packaged dimensions (WxDxH) (mm)	863 x 388 x (650+15)				
Smart Active efficiency	up to 98%				
Protections	Overcurrent - short-circuit - overvoltage - undervoltage - temperature - excessive low battery				
Communications	USB / RS232 + slot for communications interface				
Input plugs	Terminal board				
Output sockets	Terminal board + 2 IEC 320 C13				
Standards	EN 62040-1 EMC EN 62040-2 Directives 2006/95/EC - 2004/108 EC EN 62040-3				
Operating temperature	0 °C / +40 °C				
Relative humidity	< 95% non-condensing				
Colour	Dark grey RAL 7016				
Noise level at 1 m (ECO Mode)	< 45 dBA				
Moving the UPS	castors				

# Multi Sentry

## 10-20 kVA



DATACENTRE



E-MEDICAL



INDUSTRY



TRANSPORT



EMERGENCY



ONLINE



Tower



**1:1** **3:1** 10-20 kVA

**3:3** 10-20 kVA



USB  
plug



SmartGrid  
ready



Supercaps  
UPS



Energy  
share



Service  
1st start



### HIGHLIGHTS

- Large power size selection 10, 12, 15, 20 kVA
- Small footprint
- Zero impact source
- Flexibility of use
- Advanced communications

The Multi Sentry series is ideal for protecting data centres and telecommunications systems, IT networks and critical systems in general, where the risks connected with poor energy supply can compromise the continuity of activities and services. The Multi Sentry series is available in 10-12-15-20 kVA models with three-phase/single-phase input and single-phase output, and 10-12-15-20 kVA models with three-phase input and output and on-line double conversion technology in accordance with VFI-SS-111 classification (as set out in standard IEC EN 62040-3). Multi Sentry is designed and built using state-of-the-art technology and components. It is controlled

by a DSP (Digital Signal Processor) microprocessor, to provide maximum protection to the powered loads with no impact on downstream systems, and optimised energy savings.

#### Zero impact source

Multi Sentry solves installation problems in systems where the power supply has limited power available, where the UPS is supported by a generator or where there are compatibility problems with loads that generate harmonic currents; Multi Sentry has a zero impact on its power source, whether this is the mains power supply or a generator:



- input current distortion < 3%
- input power factor 0.99
- power walk-in function that ensures progressive rectifier start up
- start-up delay function, to restart the rectifiers when mains power is restored if there are several UPS in the system.

In addition, Multi Sentry plays a filtering and power factor correction role in the power network upstream of the UPS, as it eliminates harmonic components and reactive power generated by the power utilities.

### Installation flexibility

MSM /MST 10, 12, 15, 20 is available in two different cabinet frames:

- 1320 mm high housing: batteries to for back up time up to thirty minutes on 20 kVA or Isolation transformer;
- 930 mm high compact version which secure the UPS range features in an extremely reduced size;

The single phase output (MCM/MSM 10, 12, 15, 20 kVA) thanks to its highly flexible design allows full compatibility with both three-phase and single-phase power supplies, thus eliminating problems in connecting the UPS to the system.

### Battery care system

Proper battery care is critical to ensuring correct UPS operation in emergency conditions. The Riello UPS battery care system consists of a series of features and capabilities to optimise battery management and obtain the best performance and operating life possible. Battery recharging: Multi Sentry is suitable for use with hermetically sealed lead-acid (VRLA), AGM and GEL batteries and Open Vent and Nickel Cadmium batteries. Depending on the battery type, different charging methods are available:

- One-level voltage recharge, typically used for widely available VRLA AGM batteries
- Two-level voltage recharge according to IU specification
- Charge blocking system to reduce electrolyte consumption and lengthen the life of VRLA batteries.

Recharge voltage compensation based on temperature in order to prevent excessive battery charges or overheating.

Battery tests to diagnose in advance any reduction in performance or problems with the batteries. Deep discharge protection: during extended low-load discharges, the end-of-discharge voltage is increased - as recommended by battery manufacturers - to prevent damage or reduced battery performance. Ripple current: recharge ripple current (residual AC component) is one of

the main causes of reduced reliability and battery life. Using a high frequency battery charger, Multi Sentry reduces this value to negligible levels, prolonging battery life and maintaining high performance over a long period of time. Wide voltage range: the rectifier is designed to operate within a wide input voltage range (up to - 40% at half load), reducing the need for battery discharge and thus helping to extend battery life.

### Maximum reliability and availability

Distributed parallel configuration of up to 8 units per redundant (N+1) or power parallel system. The UPS continue to operate in parallel even if the connection cable is interrupted (Closed Loop).

### Operation flexibility

The compact version of the Multi Sentry (MCM/MCT 10, 12, 15, 20 kVA) features embedded auxiliary outlets for intelligent utilities supply. The "energy share" outlet is driven by relays which are customizable



Multi Sentry Compact (MCM/MCT)

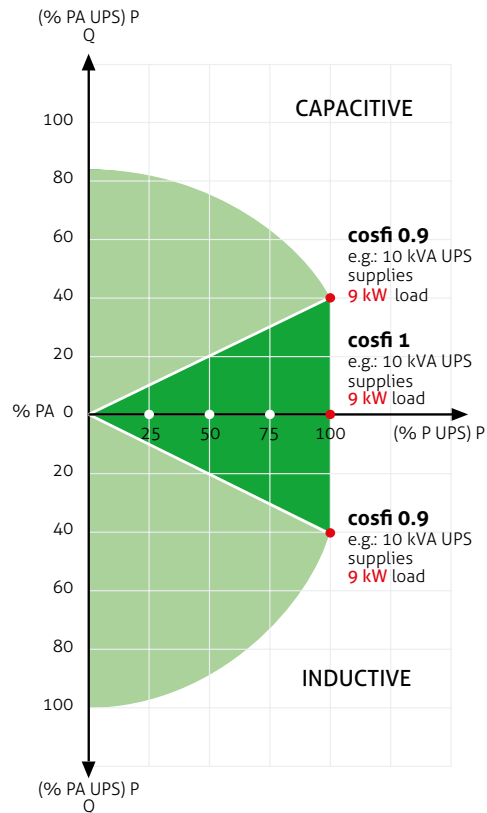

depending on the installation or customer needs, making it more suitable for protecting different critical load. On the MSM/MST Multi Sentry version the same functionality is available as optionally.

### Advanced communications

Multi Sentry is equipped with a back-lit graphic display (240x128 pixels) providing UPS information, measurements, operating states and alarms in different languages. It can also display wave forms and voltage/current forms. A wide range of communications options are available to ensure global and comprehensive UPS monitoring. Please refer to option table for details.

## BATTERY BOX

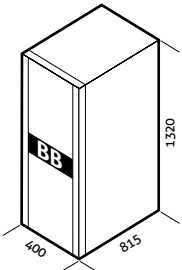
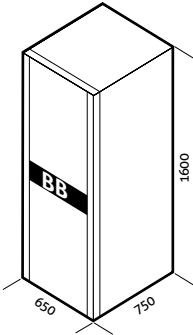
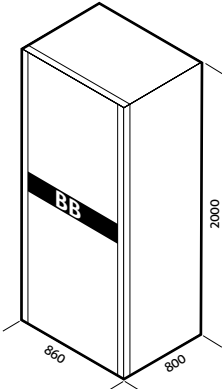
MODELS	BB 1320 480-T4 / BB 1320 480-T5 BB 1320 480-T2 / AB 1320 480-T5	BB 1600 480-S5 / AB 1600 480-S5	BB 1900 480-V6 / BB 1900 480-V7 BB 1900 480-V8 / BB 1900 480-V9 AB 1900 480-V9
UPS MODELS	MCM/MSM and MCT/MST 10-20 kVA		
Dimensions (mm)			

## DETAILS

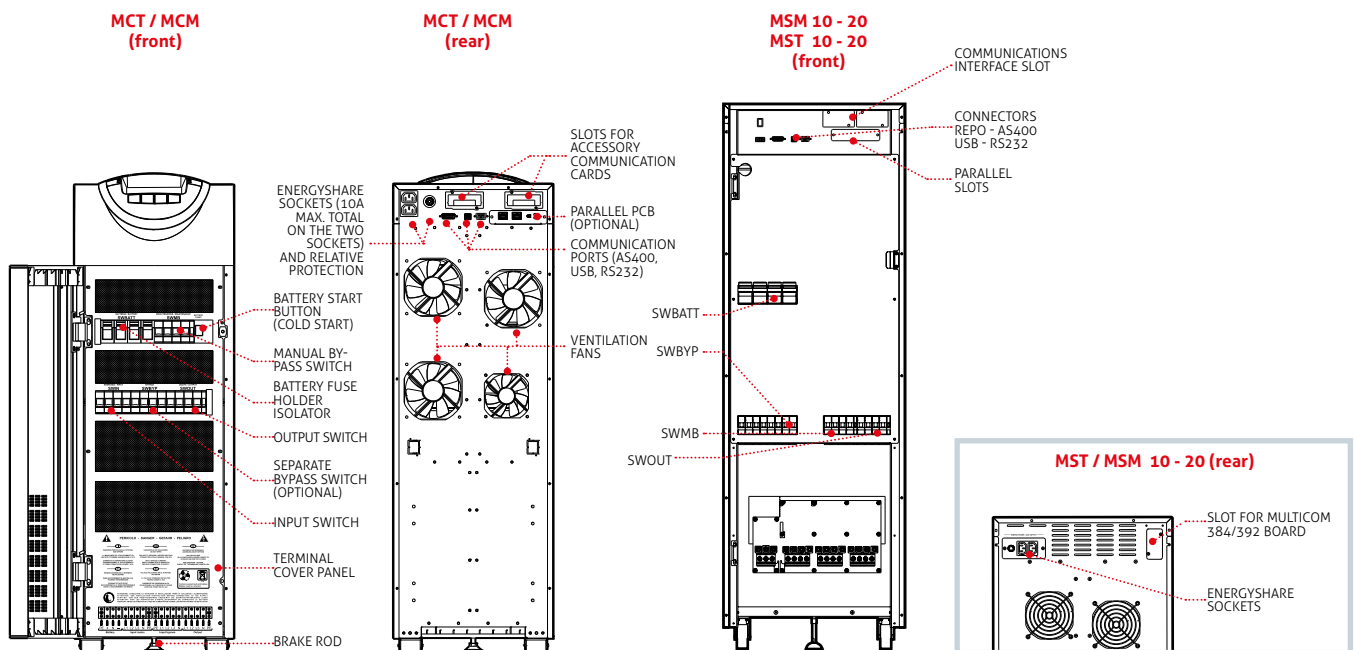

## OPTIONS

### SOFTWARE

PowerShield<sup>3</sup>  
PowerNetGuard

### ACCESSORIES

NETMAN 204  
MULTICOM 302  
MULTICOM 352  
MULTICOM 372  
MULTICOM 384

### MULTI I/O

MULTIPANEL  
MBS 100 A

### PRODUCT ACCESSORIES

Battery temperature sensor  
Powerful battery charger  
Programmable relay board  
MULTICOM 392

UPS with internal isolation transformers (MST/MSM 10-20)

UPS 220 V IN/OUT

IP rating IP31/IP42

EnergyShare sockets

MODELS	MCM/MSM 10 <sup>BAT</sup>	MCM/MSM 12 <sup>BAT</sup>	MCM/MSM 15 <sup>BAT</sup>	MCM/MSM 20 <sup>BAT</sup>	MCT/MST 10 <sup>BAT</sup>	MCT/MST 12 <sup>BAT</sup>	MCT/MST 15 <sup>BAT</sup>	MCT/MST 20 <sup>BAT</sup>
<b>INPUT</b>								
Nominal voltage	380-400-415 Vac three-phase + N / 220-230-240 Vac single-phase + N				380-400-415 Vac three-phase + N			
Nominal frequency	50/60 Hz							
Voltage tolerance	400 V ±20% @ full load							
Frequency tolerance	40 - 72 Hz							
Power factor at full load	0.99							
Current distortion	THDI ≤ 3%							
<b>BYPASS</b>								
Nominal voltage	220-230-240 Vac single-phase + N				380-400-415 Vac three phase + N			
Number of phases	1				3 + N			
Voltage tolerance (Ph-N)	180 - 264 V (selectable)							
Nominal frequency	50 or 60 Hz (selectable)							
Frequency tolerance	±5 (selectable)							
Bypass overload	125% for 60 minutes, 150% for 10 minutes							
<b>OUTPUT</b>								
Nominal power (kVA)	10	12	15	20	10	12	15	20
Active power (kW)	9	10.8	13.5	18	9	10.8	13.5	18
Power factor	0.9							
Number of phases	1				3 + N			
Nominal voltage (V)	220-230-240 Vac single-phase + N (selectable)				380-400-415 Vac three-phase + N (selectable)			
Static variation	± 1%							
Dynamic variation	± 3%							
Crest factor	3 : 1 I <sub>peak</sub> /I <sub>rms</sub>							
Voltage distortion	≤ 1% with linear load / ≤ 3% with non-linear load							
Frequency	50/60 Hz							
Frequency stability during battery operation	0.01%							
<b>BATTERIES</b>								
Type	VRLA AGM/GEL/NiCd/Li-ion/Supercaps							
Recharge time	6 hours							
<b>INFO FOR INSTALLATION</b>								
Weight without batteries (kg) (MCM/MSM)	80/105	82/110	90/115	95/120	80/105	82/110	90/115	95/120
Dimensions (WxDxH) (mm)	320 x 840 x 930 (MCM/MCT version) / 440 x 850 x 1320 (MSM/MST version)							
Communications	3 slots for communications interface / USB / RS232							
Operating temperature	0 °C / +40 °C							
Relative humidity	90% non-condensing							
Colour	Dark grey RAL 7016							
Noise level at 1 m [dBA ±2] Smart Active	< 40 dBA							
IP rating	IP20							
Smart Active efficiency	up to 98%				up to 99%			
Standards	European Directives: L V 2006/95/CE low voltage Directive EMC 2004/108/CE electromagnetic compatibility Directive Standards: Safety IEC EN 62040-1; EMC IEC EN 62040-2 Classification in accordance with IEC 62040-3 (Voltage Frequency Independent) VFI - SS - 111							
Moving the UPS	castors / Pallet Jack (10 - 20 kVA)							

<sup>BAT</sup> Also available with internal batteries

# Multi Sentry

## 30-200 kVA



DATACENTRE



E-MEDICAL



INDUSTRY



TRANSPORT



EMERGENCY



ONLINE



Tower



3:3

30-200 kVA



USB plug



SmartGrid ready



Supercaps UPS



Energy share



Service 1st start

### HIGHLIGHTS

- Complete range 30-200 kVA
- Small footprint
- High efficiency up to 96.5%
- Zero impact source
- Flexibility of use
- Advanced communications

The Multi Sentry series is ideal for protecting data centres and telecommunications systems, IT networks and critical systems in general, where the risks connected with poor energy supply can compromise the continuity of activities and services. The Multi Sentry series is available in 30-40-60-80-100-125-160-200 kVA models with three-phase input and output and on-line double conversion technology in accordance with VFI-SS-111 classification (as set out in standard IEC EN 62040-3). Multi Sentry is designed and built using state-of-the-art technology and components. It has a fully controlled IGBT rectifier to minimize the impact on the grid.

It is controlled by a DSP (Digital Signal Processor) microprocessor, to provide maximum protection to the powered loads with no impact on downstream systems, and optimised energy savings.

#### Zero impact source

Multi Sentry solves installation problems in systems where the power supply has limited power available, where the UPS is supported by a generator or where there are compatibility problems with loads that generate harmonic currents; Multi Sentry has a zero impact on its power source, whether this is the mains power supply or a generator:



- input current distortion < 2.5%
- input power factor 0.99
- power walk-in function that ensures progressive rectifier start up
- start-up delay function, to restart the rectifiers when mains power is restored if there are several UPS in the system.

In addition, Multi Sentry plays a filtering and power factor correction role in the power network upstream of the UPS, as it eliminates harmonic components and reactive power generated by the power utilities.

### High efficiency

State-of-the-art three-level NPC inverters are used across the power range (30-200) to achieve an operating efficiency of 96.5%. This technology halves (50%) the energy dissipated in a year by traditional UPS, with an efficiency level of 92%. Its exceptional performance makes it possible to recover the capital investment cost in less than three years of operation.

### Battery care system

Proper battery care is critical to ensuring correct UPS operation in emergency conditions. The Riello UPS battery care system consists of a series of features and capabilities to optimise battery management and obtain the best performance and operating life possible.

**Battery recharging:** Multi Sentry is suitable for use with hermetically sealed lead-acid (VRLA), AGM and GEL batteries and Open Vent and Nickel Cadmium batteries.

Depending on the battery type, different charging methods are available:

- One-level voltage recharge, typically used for widely available VRLA AGM batteries
- Two-level voltage recharge according to IU specification
- Charge blocking system to reduce electrolyte consumption and lengthen the life of VRLA batteries.

Recharge voltage compensation based on temperature in order to prevent excessive battery charges or overheating.

Battery tests to diagnose in advance any reduction in performance or problems with the batteries.

**Deep discharge protection:** during extended low-load discharges, the end-of-discharge voltage is increased - as recommended by battery manufacturers - to prevent damage or reduced battery performance.

**Ripple current:** recharge ripple current (residual AC component) is one of the main causes of reduced reliability and battery life. Using a high frequency battery charger, Multi Sentry reduces this value to negligible

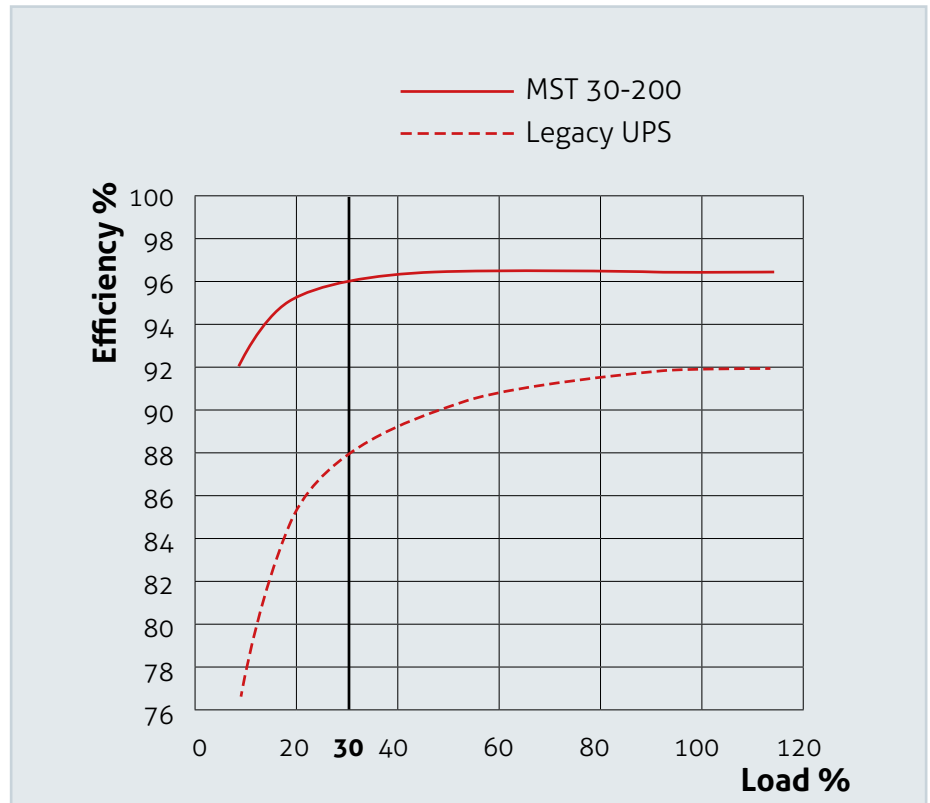

levels, prolonging battery life and maintaining high performance over a long period of time.

**Wide voltage range:** the rectifier is designed to operate within a wide input voltage range (up to - 40% at half load), reducing the need for battery discharge and thus helping to extend battery life.

### Maximum reliability and availability

Distributed parallel configuration of up to 8 units per redundant (N+1) or power parallel system. The UPS continue to operate in parallel even if the connection cable is interrupted (Closed Loop).

### Low running costs

Advanced technology and use of high performance components, allows Multi Sentry to provide exceptional performance and efficiency, with a compact size:

- the smallest overall footprint is only 0.37 sqm for Multi Sentry 40 kVA with batteries
- the type of input stage (IGBT rectifier) ensures an input power factor close to 1 with low current distortion, avoiding the need for bulky and expensive filters
- unity output power factor for MST 160 - 200 make it suitable to any data centre application ensuring full power availability no matter what the utilities power factor range (typically from 0.9 lagging to 0.9 leading)



- more active power than a traditional UPS, guaranteeing a greater margin when sizing UPS for potential future load increases.
- smart ventilation principle on MST 160-200 manages the number of operating fans and their speed according to room temperature and load level. This preserves the life span of the fans and at the same time we reduce noise level and overall power consumption for unnecessary UPS ventilation.

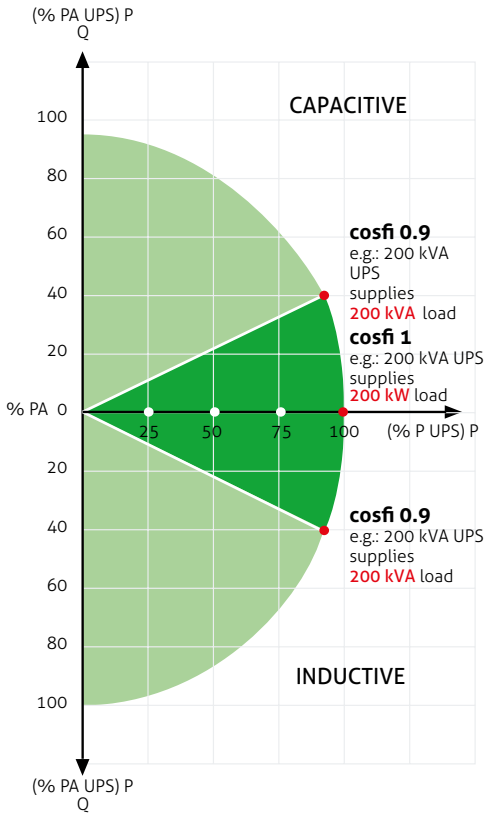

### Flexibility

With its flexible configuration, performance, accessories and options, Multi Sentry is suitable for use in a wide range of applications:

- suitable for powering capacitive loads, such as blade servers, without any reduction in active power from 0.9 lead to 0.9 lag
- On-line, Eco, Smart Active and Stand By Off operating modes - compatible with centralised power systems (CSS) applications.
- frequency converter mode
- configurable EnergyShare sockets to preserve runtime for the most critical loads or to be activated only when mains power fails
- Cold Start to switch on the UPS even when there is no mains power present
- MST 30-40 version: cabinet (1320 x 440 x 850 mm HxWxD) for optimised solutions when medium to long-term runtimes are required.



Multi Sentry MST 160-200

- optional temperature sensor for external battery cabinets, to assist recharge voltage compensation
- high power battery chargers to optimise charge time in the event of long runtimes
- optional dual input mains power supply
- isolation transformers for modifying the neutral earthing (separate power sources), or for galvanic isolation between the input and output
- 220 V three-phase IN/OUT version and 50/60 Hz frequency for 10-40 kVA power ratings
- different sized battery cabinets and capacities, for extended runtimes
- with the MST 60-100 the UPS can be raised up to 25 cm from the ground to allow the cables to pass more freely to/from the UPS terminal board
- MST 160-200 could be equipped with a side mounted top entry cabinet to arrange UPS cabling from the top.

### Advanced communications

Multi Sentry is equipped with a backlit graphic display (240x128 pixels) providing UPS information, measurements, operating states and alarms in different languages. It can also display waveforms and voltage/current forms.

The default screen displays UPS status, graphically indicating the status of the various assemblies (rectifier, batteries, inverter, bypass).

- Advanced multi-platform communications for all operating systems and network environments: PowerShield<sup>3</sup> monitoring and shutdown software included for Windows operating systems 10, 8, 7, Hyper-V, 2016, 2012, and previous versions, Mac OS X, Linux, VMWare ESXi, Citrix XenServer and other Unix operating systems



MST 60-100 with Socle box (h: 1850 mm)



Multi Sentry MST 160-200 with top cable entry

- Compatible with TeleNetGuard remote monitoring service
- RS232 serial and USB ports
- 3 slots for the installation of optional communications accessories such as network adapters, potential free contacts, etc.
- REPO Remote Emergency Power Off for switching off the UPS via a remote emergency button
- Input for the connection of the auxiliary contact of an external manual bypass
- Input for synchronisation from an external source
- Graphic display panel for remote connection.

## BATTERY BOX

MODELS	BB 1320 480-T4 / BB 1320 480-T5 BB 1320 480-T2 / AB 1320 480-T5	BB 1600 480-S5 / AB 1600 480-S5	BB 1900 480-V6 / BB 1900 480-V7 BB 1900 480-V8 / BB 1900 480-V9 AB 1900 480-V9
UPS MODELS	up to 60 kVA	up to 80 kVA	up to 200 kVA
Dimensions WxDxH (mm)	400x815x1320 <i>BB 1320 480-T4 Not available for MST 40-60</i> <i>BB 1320 480-T2 Not available for MST 60</i>	605x750x1600	860x800x1900 <i>BB 1900 480-V6 / BB 1900 480-V7</i> <i>Not available for MST 160-200</i>

## DETAILS

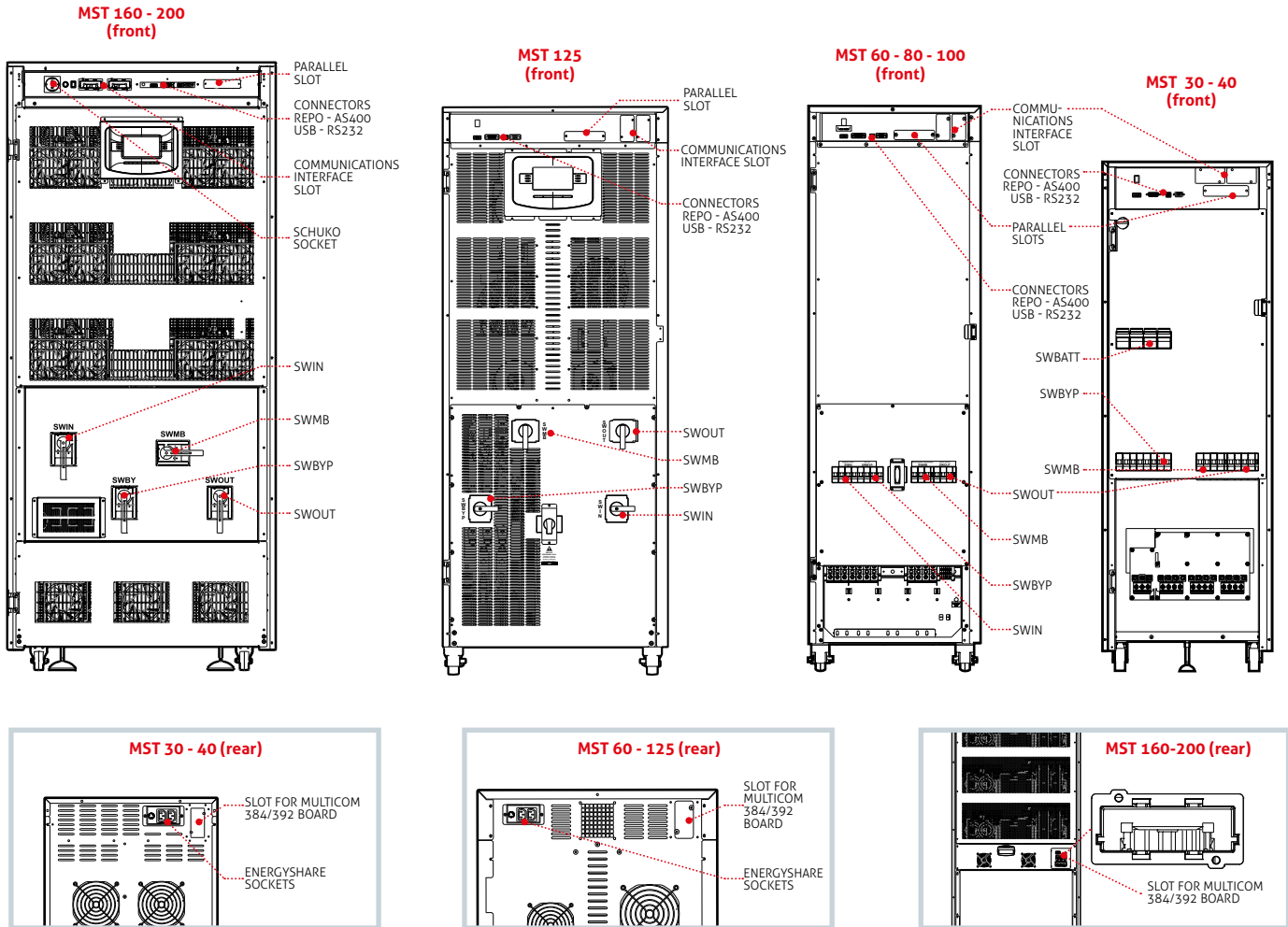

## OPTIONS

### SOFTWARE

PowerShield<sup>3</sup>  
PowerNetGuard

### ACCESSORIES

NETMAN 204  
MULTICOM 302  
MULTICOM 352  
MULTICOM 372  
MULTICOM 384  
MULTI I/O

MULTIPANEL  
MBB 100 A

### PRODUCT ACCESSORIES

Battery temperature sensor  
Powerful battery charger  
Programmable relay board  
MULTICOM 392  
UPS with internal isolation  
transformers (30-40 kVA)  
UPS 220 V IN/OUT

IP rating IP31/IP42  
Socle Box for MST 60-100  
EnergyShare sockets

Top cable entry for MST 160-200  
Eyebolts kit for MST 160-200

MODELS	MST 30 <sup>BAT</sup>	MST 40 <sup>BAT</sup>	MST 60	MST 80	MST 100	MST 125	MST 160	MST 200
<b>INPUT</b>								
Nominal voltage	380-400-415 Vac three-phase + N							
Nominal frequency	50/60 Hz							
Voltage tolerance	400 V $\pm$ 20% @ full load							
Frequency tolerance	40 - 72 Hz							
Power factor at full load	0.99							
Current distortion	THDI $\leq$ 3%						THDI $\leq$ 2.5%	
<b>BYPASS</b>								
Nominal voltage	380-400-415 Vac three-phase + N							
Number of phases	3 + N							
Voltage tolerance (Ph-N)	180 - 264 V (selectable)							
Nominal frequency	50 or 60 Hz (selectable)							
Frequency tolerance	$\pm$ 5% (selectable)							
Bypass overload	125% for 60 minutes, 150% for 10 minutes							
<b>OUTPUT</b>								
Nominal power (kVA)	30	40	60	80	100	125	160	200
Active power (kW)	27	36	54	72	90	112.5	160	200
Power factor	0.9						1	
Number of phases	3 + N							
Nominal voltage	380-400-415 Vac three-phase + N (selectable)							
Static variation	$\pm$ 1%							
Dynamic variation	$\pm$ 3%							
Crest factor	3 : 1 I <sub>peak</sub> /I <sub>rms</sub>							
Voltage distortion	$\leq$ 1% with linear load / $\leq$ 3% with non-linear load							
Frequency	50/60 Hz							
Frequency stability during battery operation	0.01%							
<b>BATTERIES</b>								
Type	VRLA AGM/GEL/NiCd/Li-ion/Supercaps							
Recharge time	6 hours							
<b>INFO FOR INSTALLATION</b>								
Weight without batteries (kg) (MCT/MST)	135	145	190	200	220	250	450	460
Dimensions (WxDxH) (mm)	440 x 850 x 1320		500 x 850 x 1600			650 x 840 x 1600	850 x 1050 x 1900	
Communications	3 slots for communications interface / USB / RS232							
Operating temperature	0 °C / +40 °C							
Relative humidity	90% non-condensing							
Colour	Dark grey RAL 7016							
Noise level at 1 m [dBA $\pm$ 2] (Smart Active)	< 40 dBA		< 63 dBA				< 50 dBA	
IP rating	IP20							
Smart Active efficiency	up to 99%							
Standards	European Directives: L V 2006/95/CE low voltage Directive EMC 2004/108/CE electromagnetic compatibility Directive Standards: Safety IEC EN 62040-1; EMC IEC EN 62040-2 Classification in accordance with IEC 62040-3 (Voltage Frequency Independent) VFI - SS - 111							
Moving the UPS	castors (30 - 200 kVA)							

<sup>BAT</sup> Also available with internal batteries







DATACENTRE



E-MEDICAL



INDUSTRY



TRANSPORT



EMERGENCY

# NextEnergy



ONLINE



Tower



**3:3** 200-400 kVA

## NextEnergy



USB plug



SmartGrid ready



Flywheel compatible



Supercaps UPS



Service 1st start



### HIGHLIGHTS

- High efficiency up to 97% in double conversion
- kW = kVA (pf 1) up to 40°C
- Transformerless UPS
- High overload capacity
- Interactive Touch Screen
- Full front access, back to back install

Riello UPS Introduces NextEnergy, the latest UPS series designed for mission critical applications. The three phase UPS offers transformerless double conversion technology VFI SS 111, with integrated IGBT three-level design. NextEnergy is designed to meet the power requirements of tomorrow, offering high efficiency and low running cost. Thanks to the Efficiency Control System, NextEnergy also guarantees the highest levels of efficiency even at partial loads. Its unity power factor and easy system upgrading make it the ideal solution for the business continuity of any IT application.

### Zero impact source

NextEnergy is designed with the latest technology to not only prevent disturbances on the mains but clean the power e.g.. Harmonics generated by non-linear loads. The input AC/DC converter is based on the IGBT rectifier design using the latest 3-level technology. The key features are:

- input current distortion < 3%
  - input power factor 0.99
  - power walk-in function that ensures progressive rectifier start-up
  - start-up delay function, to restart the rectifiers when mains power is restored.
- Thanks to the programmable maximum input power (kW or kVA), NextEnergy can be installed into AC supply systems with limited power availability such as a diesel generator

or contractually reduced power sources, and then supply the additional power required using the batteries (peak demand function).

### Outstanding performances

- The latest technology of NextEnergy and the careful selection of high-quality components help to achieve first-class performance such as unity power factor (kW/kVA) and the capability to supply capacitive loads, which are very common in most Data Centres, without any power derating up to 40 °C.
- Outstanding system efficiency up to 97% in on-line double conversion mode, increasing to 99% in stand-by mode or smart-active.
- The unit design adopts the forced ventilation method to extract the heat produced by the internal components. Specific attention has been given to the ventilation system to ensure the best operational level and lifetime. This is thanks to the automatic speed control which constantly adjusts to the specific load level, the fan failure alarm and the fan redundancy - with condition apply.

### Battery care system

The battery is one of the most important parts of the UPS that ensures the correct operation in case of mains failure. NextEnergy includes all the latest features to prolong the battery life and keep the battery working efficiently, as well as advising users about any potential problem. The variety of charging methods allows the use of the most common type of battery and technologies available on the market such as VLRA, AGM, GEL, NicCd etc.

In addition to the flexibility of the battery cells, NextEnergy allows users to choose the most cost-effective solution for the required back-up time. The battery charging and discharging is assured by the STEP-UP/STEP-DOWN converter which means that when the batteries are charged and the mains is available, the converter is no longer connected to the supply. This means the ripple current is practically zero which leads to a significant improvement in battery life.

### Operation without Neutral

NextEnergy can work with or without the neutral connection. This is an important feature to reduce the TCO of the distribution system where the neutral is created by an isolation transformer close to the load. For example, in the modern Data Centre, or where the neutral is not used at all.

The major benefit being a reduced cost of the distribution arrangements.

### Easy installation

- The small footprint of the cabinet and complete front access for all maintenance activities, ensures maximum space for installation and service.
- NextEnergy includes top and bottom cable entry as standard, removing the need for large and costly top entry cabinets.
- Ventilation is from the front to the top so no additional rear clearance required.

### Maximum reliability and availability

NextEnergy UPS can be connected in parallel with up to 8 units to increase the capacity or add redundancy (N+1). Considering that a typical load can vary from 20 to 80%, the Efficiency Control System (ECS) function optimises the operating efficiency of the entire system according to the power absorbed by the load. This ensures higher overall efficiency during all load conditions. Hot System Expansion (HSE) allows the addition of further UPS into an existing system, without the need to switch off the operational units or transfer them to bypass mode. This guarantees maximum load protection, even during maintenance and system expansion. It ensures maximum levels of availability - even in the event of an interruption to the parallel control cable the system is "FAULT TOLERANT". It is not affected by connection cable faults and continues powering the load without disruption, signaling an alarm condition.

### Interactive Touch Screen

NextEnergy is equipped with a Touch screen 7" graphic display (800x480 pixels) providing UPS information, measurements, voltage and current waveforms, operating states and alarms in different languages. The default screen displays the UPS status, graphically indicating the status of the various assemblies (rectifier, batteries, inverter, bypass). Also, the panel is used for configuration and setting the parameters of the UPS with 3 levels of the security password.

### Advanced Communication

NextEnergy offers the capability to work with the advanced multi-platform communications for all the latest operating systems and network environments.

- PowerShield<sup>3</sup> monitoring and shutdown software included for Windows operating systems 10, 8, 7, Hyper-V, 2016, 2012, and previous versions, Mac OS X, Linux, VMWare ESXi, Citrix XenServer and other Unix operating systems.
- Compatible with PowerNetGuard remote monitoring service.
- 2 slots for the installation of the optional communication accessories such as network adapters and BMS interface.
- Ethernet and USB ports.
- Relay cards with customized alarms and commands.



## OPTIONS

### SOFTWARE

PowerShield<sup>3</sup>  
PowerNetGuard

### ACCESSORIES

NETMAN 204  
MULTICOM 302

MULTICOM 352

Multi I/O  
I/O Expansion board

### PRODUCT ACCESSORIES

Isolation transformer  
Parallel configuration kit

Synchronisation device (UGS)

Hot connection device (PSJ)

Battery cabinets empty or for  
extended runtimes

IP rating IP31/IP42

## DIMENSIONS

**NXE 200**

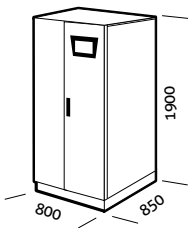

**NXE 250  
NXE 300**

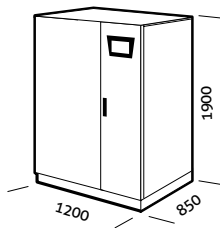

**NXE 400**

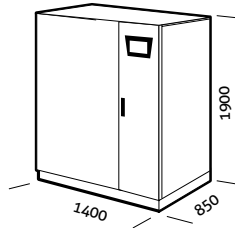

## BATTERY BOX

### MODELS

BB 1900 480-V6 / BB 1900 480-V7  
BB 1900 480-V8 / BB 1900 480-V9

### UPS MODELS

NXE 200-250-300-400

Dimen-  
sions  
(mm)

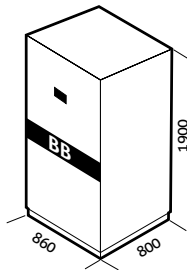

## THREE-PHASE ISOLATION TRANSFORMERS

### MODELS

TBX 200 T - TBX 250 T

### UPS MODELS

NXE 200 - 250

TBX 300 T - TBX 400 T

NXE 300 - 400

Dimensions  
(mm)

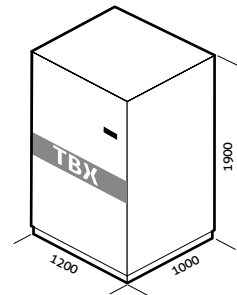
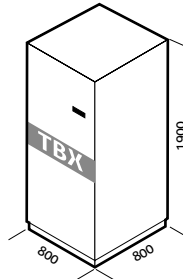



MODELS	NXE 200	NXE 250	NXE 300	NXE 400
<b>INPUT</b>				
Nominal Voltage	380-400-415 Vac three-phase			
Voltage tolerance	+ 20% - 40% (with restrictions)			
Frequency	45 - 65 Hz			
Power factor	0.99			
Harmonic current distortion	< 3%			
Soft Start	0 - 100 % in 120 sec (selectable)			
Standard equipment provided	Back feed protection, separate bypass line			
<b>BYPASS</b>				
Nominal voltage	380-400-415 Vac three phase + N			
Nominal frequency	50 or 60 Hz (selectable)			
Frequency tolerance	± 2% (selectable from ± 1% to ± 5%)			
<b>OUTPUT</b>				
Nominal Power (kVA)	200	250	300	400
Active Power (kW)	200	250	300	400
Number of phases	3 + N			
Nominal Voltage	380 - 400 - 415 Vac three-phase + N (selectable)			
Static Stability	± 1%			
Dynamic Stability	± 5% in 10 ms			
Voltage distortion	< 1% with linear load/< 3% with non-linear load			
Frequency stability on battery	± 0.05 %			
Frequency	50 or 60 Hz (selectable)			
Overload	110% for 60'; 125% for 10'; 150 % for 1'			
<b>BATTERIES</b>				
Type	VLRA AGM / GEL, NiCd, Supercaps, Li-ion, Flywheels			
Ripple current	Zero			
Recharge voltage compensation	-0.11 V x °C			
<b>INFO FOR INSTALLATION</b>				
Weight (kg)	750	800	1100	
Dimension (WxDxH) (mm)	800 x 850 x 1900	1200 x 850 x 1900	1400 x 850 x 1900	
Input cable	Bottom	Top and bottom	Top and bottom	
Remote signals	Volt-free contact (configurable)			
Remote controls	EPO, bypass and another spare			
Communications	USB + Dry contacts + 2 slots for communications interface			
Operating temperature	0 °C to 40 °C			
Relative humidity	5 to 95 % non-condensing			
Colour	Dark grey RAL 7016			
IP rating	IP 20 (other on request)			
Efficiency (AC-AC) – On line mode	up to 97%			
Standards	Safety: EN 62040-1 (directive 2014/35/UE); EMC: EN 62040-2 (directive 2014/30/UE)			
Classification in accordance with IEC 62040-3	(Voltage Frequency Independent) VFI - SS - 111			
Moving the UPS	Pallet Jack			

# Master MPS



DATA CENTRE



E-MEDICAL



INDUSTRY



TRANSPORT



EMERGENCY



ONLINE



Tower



**3:1** 10-100 kVA

**3:3** 10-200 kVA



SmartGrid ready



Flywheel compatible



Supercaps UPS



Service 1st start



## HIGHLIGHTS

- Efficiency Control System (ECS)
- Robust and reliable
- Galvanic isolation
- High overload capacity
- Extensive parallel configurations

### Total protection

Master MPS series UPS provide maximum protection and power quality for mission critical loads, including data centres, industrial processes, telecommunications, security and electro-medical systems. Master MPS is an on-line double conversion UPS (VFI SS 111 - IEC EN 62040-3) with a transformer isolated inverter.

The Master MPS range includes three-phase input and single-phase output versions from 10 to 100 kVA, and three-phase input and

output versions from 10 to 200 kVA.

All versions are provided with a 6-pulse thyristor-based rectifier, with or without optional harmonic filters.

A 12-pulse thyristor-based rectifier is available on request for the 60 and 80 kVA versions with or without optional harmonic filters.

### Easy source

Master MPS makes supplying the UPS from generator sets and MT/BT transformers

simpler and more efficient, reducing power loss in the system and coils, correcting the power factor and eliminating current harmonics created by the loads supplied by the UPS.

In addition to this, the progressive rectifier start-up (power walk-in) and the option to reduce battery charging currents, allow for a reduction in the input current uptake. This means less demand on the source, which is particularly useful when the source is a generator set.

### Flexibility

Master MPS is suitable for a wide range of applications including IT and the most demanding industrial environments. The UPS is suitable for power capacitive loads such as blade servers, from 0.9 leading to 0.8 lagging. With a broad range of accessories and options, complex configurations and system architectures can be achieved to guarantee maximum power availability and the option to add new UPS without interruption to existing installation.

### Battery care system: maximum battery care

Normally the batteries are kept charged by the rectifier; when mains power fails, the UPS uses this energy source to power the consumers. Proper battery care is therefore critical to ensuring correct UPS operation under emergency conditions. The Riello UPS battery care system consists of a series of functions designed to optimise battery management and achieve the best performance and operating life possible. Master MPS is also compatible with different battery technologies: vented open lead acid, VRLA AGM, Gel, NiCd, Flywheels, Supercaps and Lithium.

### Specific solutions

The UPS can be adapted to meet the most specific requirements. Contact our TEC team to discuss specific solutions and options not listed in this catalogue.

### Advanced communications

- Compatible with TeleNetGuard for remote monitoring.
- Advanced multi-platform communications for all operating systems and network environments: PowerShield<sup>3</sup> monitoring and shutdown software included for Windows operating systems 10, 8, 7, Hyper-V, 2016, 2012, and previous versions, Mac OS X, Linux, VMWare ESXi, Citrix XenServer and other Unix operating systems.
- Double RS232 serial
- 2 slots for the installation of optional

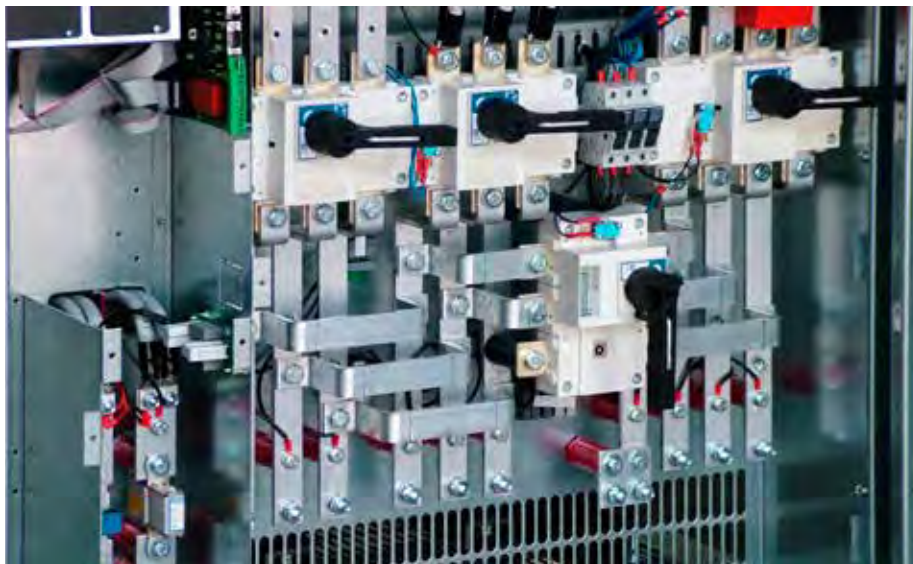

Detail of connection area

communications accessories such as network adapters, potential free contacts, etc.

- REPO Remote Emergency Power Off for switching off the UPS via a remote emergency button
- Input for the connection of the auxiliary contact of an external manual bypass
- Input for synchronisation from an external source
- Graphic display panel for remote connection.

### Maximum reliability and availability

- Distributed or centralised parallel configuration of up to 8 units per redundant (N+1) or power parallel system. Parallel configurations using models with different power ratings are also possible.
- Hot System Expansion (HSE): allows the addition of a further UPS into an existing system, without the need to switch off the existing UPS or transfer them to bypass mode. This guarantees maximum load protection, even during maintenance and system expansion.
- Maximum levels of availability, even in the event of an interruption to the parallel bus cable: the system is "FAULT TOLERANT". It is not affected by connection cable faults and continues powering the load without disruption, signalling an alarm condition.
- Efficiency Control System (ECS): a system to optimise the operating efficiency of parallel systems, according to the power required by the load. N+1 redundancy is guaranteed, with every UPS working in parallel at the best load level possible to achieve higher overall efficiency.

### Options

#### • UPS Group Synchroniser (UGS)

Allows two or more non-parallel UPS devices to remain synchronised even during mains power failure. The UGS also enables a Riello UPS to be synchronised with another power source that is independent and of a different power rating.

#### • Parallel Systems Joiner (PSJ)

Allows two groups of UPS to be connected in parallel whilst operating, in the event of maintenance (with no interruption to the output), using a power coupling switch. Should one of the UPS in one of the parallel groups fail, it is automatically excluded. The PSJ connects the remaining UPS, to the other parallel group via an external bypass, in order to continue to guarantee load redundancy.

## DIMENSIONS

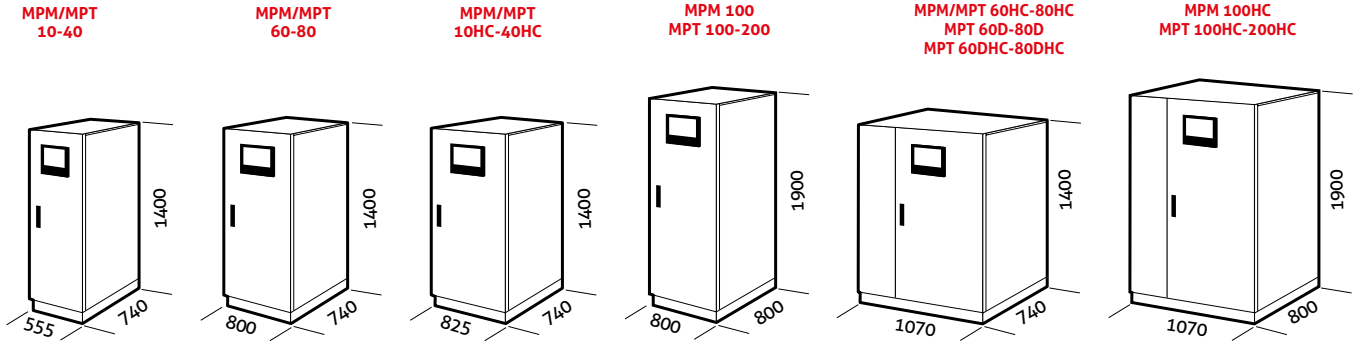

HC= Version with filtering of 5<sup>th</sup> or 11<sup>th</sup> harmonics D= Twelve-phase version

## DYNAMIC DUAL BUS CONFIGURATION

Solution to ensure redundancy up to the distribution of the power supply to the loads and improved STS operation.  
**+ Downstream fault discrimination**

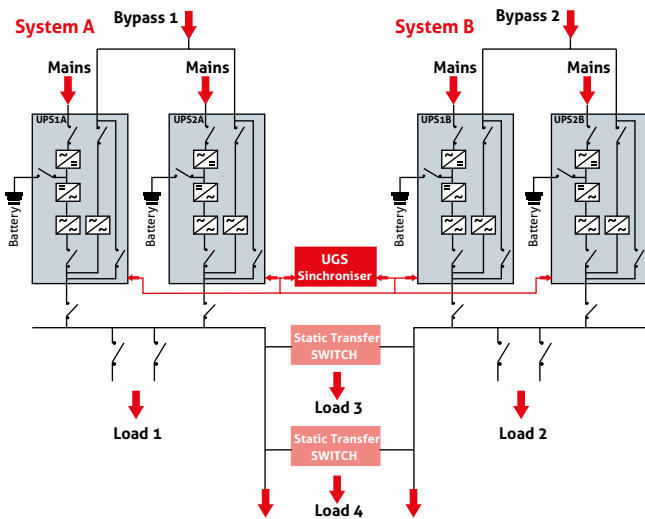

## DUAL BUS SYSTEM CONFIGURATION

Solution to ensure redundancy of the power supply even during maintenance. **+ High availability and redundancy**

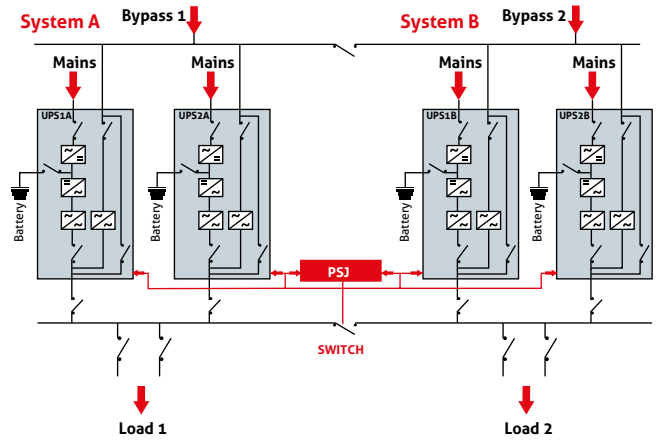

## DETAILS



MPT 200 open

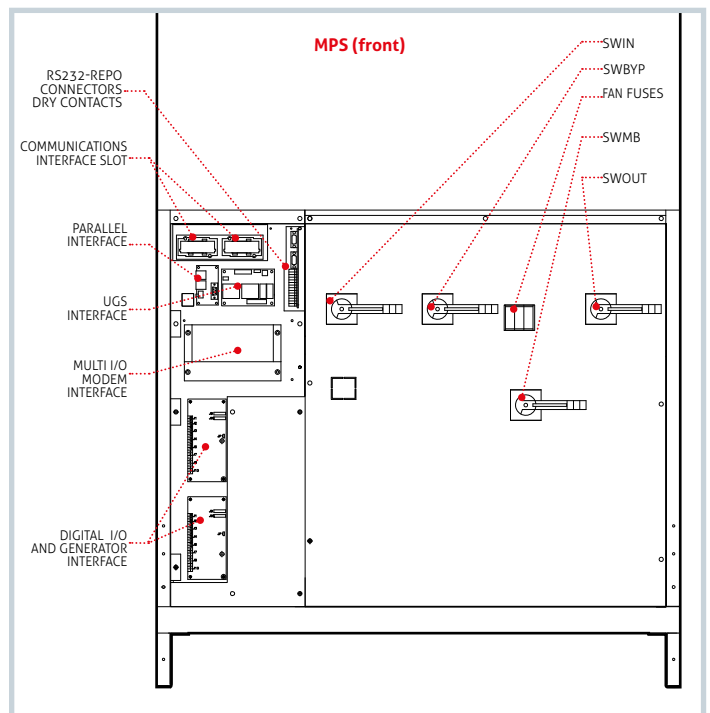



## OPTIONS

### SOFTWARE

PowerShield<sup>3</sup>  
PowerNetGuard

### ACCESSORIES

NETMAN 204  
MULTICOM 302  
MULTICOM 352  
MULTI I/O

MULTIPANEL  
MBB 100 A

### PRODUCT ACCESSORIES

Filtering of 5<sup>th</sup> and 11<sup>th</sup> harmonics (HC)  
Isolation transformer  
Synchronisation device (UGS)  
Hot connection device (PSJ)  
Digital I/O and Generator interface

Parallel configuration kit (Closed Loop)  
Battery cabinets empty or for extended runtimes  
Top Cable Entry cabinets  
IP rating IP31/IP42

## BATTERY BOX

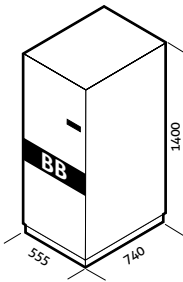
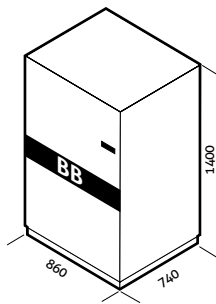
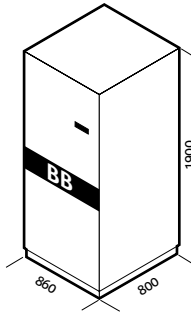
MODELS	BB 1400 384-B1	BB 1400 384-B2 / BB 1400 384-B3 BB 1400 384-B4	BB 1900 396-L6 / BB 1900 396-L7 BB 1900 396-L8 / BB 1900 396-L9
UPS MODELS	MPT 10-60 / MPM 10-60	MPT 10-80 / MPM 10-80	MPT 100-200 / MPM 100
Dimensions (mm)			

## CABINETS WITH TOP ACCESS FOR CABLES

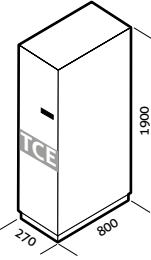
MODELS	TCE MPT 100-200
UPS MODELS	MPT 100-200 / MPM 100
Dimensions (mm)	

## SINGLE-PHASE ISOLATION TRANSFORMERS

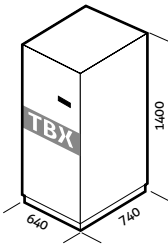
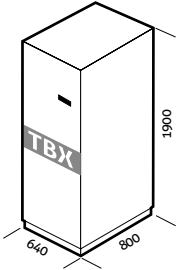
MODELS	TBX 10 M - TBX 80 M	TBX 100 M
UPS MODELS	MPM 10-80	MPM 100
Dimensions (mm)		

## THREE-PHASE ISOLATION TRANSFORMERS

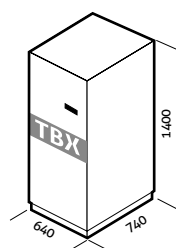
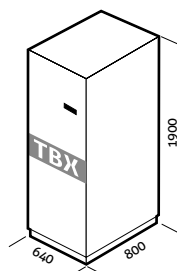
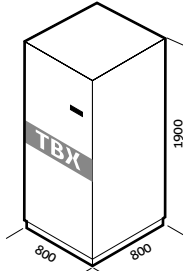
MODELS	TBX 10 T - TBX 80 T	TBX 100 T - TBX 160 T	TBX 200 T - TBX 250 T
UPS MODELS	MPT 10-80	MPT 100-160	MPT 200
Dimensions (mm)			

MODELS	MPM 10 <sup>BAT</sup>	MPM 15 <sup>BAT</sup>	MPM 20 <sup>BAT</sup>	MPM 30	MPM 40	MPM 60	MPM 80	MPM 100	
<b>INPUT</b>									
Nominal voltage	380 - 400 - 415 Vac three-phase								
Voltage tolerance	400 V + 20% / - 25%								
Frequency	45 - 65 Hz								
Soft start	0 - 100% in 120" (selectable)								
Permitted frequency tolerance	± 2% (selectable from ± 1% to ± 5% from front panel)								
Standard equipment provided	Back Feed protection; separable bypass line								
<b>BYPASS</b>									
Nominal voltage	220 - 230 - 240 Vac single-phase + N								
Nominal frequency	50 or 60 Hz (selectable)								
<b>OUTPUT</b>									
Nominal power (kVA)	10	15	20	30	40	60	80	100	
Active power (kW)	9	13.5	18	27	36	54	72	90	
Number of phases	1								
Nominal voltage	220 - 230 - 240 Vac single-phase + N (selectable)								
Static stability	± 1%								
Dynamic stability	± 5% in 10 ms								
Voltage distortion	< 1% with linear load / < 3% with non-linear load								
Crest factor	3:1 I <sub>peak</sub> /I <sub>rms</sub>								
Frequency stability on battery	0.05%								
Frequency	50 or 60 Hz (selectable)								
Overload	110% for 60 minutes; 125% for 10 minutes; 150% for 1 minute								
<b>BATTERIES</b>									
Type	VRLA AGM / GEL; NiCd; Supercaps; Li-ion; Flywheels								
Residual ripple voltage	< 1%								
Temperature compensation	-0.5 Vx°C								
Typical charge current	0.2 x C10								
<b>INFO FOR INSTALLATION</b>									
Weight without batteries (kg)	200	220	230	270	302	440	500	580	
Dimensions (WxDxH) (mm)	555 x 740 x 1400					800 x 740 x 1400		800 x 800 x 1900	
Remote signals	dry contacts								
Remote controls	ESD and bypass								
Communications	Double RS232 + dry contacts + 2 slots for communications interface								
Operating temperature	0 °C/ +40 °C								
Relative humidity	<95% non-condensing								
Colour	Dark grey RAL 7016								
Noise level at 1 m (ECO Mode)	60 dBA				62 dBA				
IP rating	IP20								
Smart Active efficiency	up to 98%								
Standards	Directives LV 2006/95/EC - 2004/108/EC; Safety IEC EN 62040-1; EMC IEC EN 62040-2; Performance IEC EN 62040-3								
Classification in accordance with IEC 62040-3	(Voltage Frequency Independent) VFI - SS - 111								
Moving the UPS	Pallet Jack								

<sup>BAT</sup> Also available with internal batteries

MODELS	MPT 10 <sup>BAT</sup>	MPT 15 <sup>BAT</sup>	MPT 20 <sup>BAT</sup>	MPT 30	MPT 40	MPT 60	MPT 80
<b>INPUT</b>							
Nominal voltage	380 - 400 - 415 Vac three-phase						
Voltage tolerance	400 V + 20% / - 25%						
Frequency	45 - 65 Hz						
Soft start	0 - 100% in 120" (selectable)						
Permitted frequency tolerance	± 2% (selectable from ± 1% to ± 5% from front panel)						
Standard equipment provided	Back Feed protection; separable bypass line						
<b>BYPASS</b>							
Nominal voltage	380 - 400 - 415 Vac three-phase + N						
Nominal frequency	50 or 60 Hz (selectable)						
<b>OUTPUT</b>							
Nominal power (kVA)	10	15	20	30	40	60	80
Active power (kW)	9	13.5	18	27	36	54	72
Number of phases	3 + N						
Nominal voltage	380 - 400 - 415 Vac three-phase + N (selectable)						
Static stability	± 1%						
Dynamic stability	± 5% in 10 ms						
Voltage distortion	< 1% with linear load / < 3% with non-linear load						
Crest factor	3:1 I <sub>peak</sub> /I <sub>rms</sub>						
Frequency stability on battery	0.05%						
Frequency	50 or 60 Hz (selectable)						
Overload	110% for 60 minutes; 125% for 10 minutes; 150% for 1 minute						
<b>BATTERIES</b>							
Type	VRLA AGM / GEL; NiCd; Supercaps; Li-ion; Flywheels						
Residual ripple voltage	< 1%						
Temperature compensation	-0.5 V/°C						
Typical charge current	0.2 x C10						
<b>INFO FOR INSTALLATION</b>							
Weight without batteries (kg)	228	241	256	315	335	460	540
Dimensions (WxDxH) (mm)	555 x 740 x 1400					800 x 740 x 1400	
Remote signals	dry contacts						
Remote controls	ESD and bypass						
Communications	Double RS232 + dry contacts + 2 slots for communications interface						
Operating temperature	0 °C / +40 °C						
Relative humidity	<95% non-condensing						
Colour	Dark grey RAL 7016						
Noise level at 1 m (ECO Mode)	60 dBA				62 dBA		
IP rating	IP20						
Smart Active efficiency	up to 98%						
Standards	Directives LV 2006/95/EC - 2004/108/EC; Safety IEC EN 62040-1; EMC IEC EN 62040-2; Performance IEC EN 62040-3						
Classification in accordance with IEC 62040-3	(Voltage Frequency Independent) VFI - SS - 111						
Moving the UPS	Pallet Jack						

<sup>BAT</sup> Also available with internal batteries

MODELS	MPT 100	MPT 120	MPT 160	MPT 200
<b>INPUT</b>				
Nominal voltage	380 - 400 - 415 Vac three-phase			
Voltage tolerance	400 V + 20% / - 25%			
Frequency	45 - 65 Hz			
Soft start	0 - 100% in 120" (selectable)			
Permitted frequency tolerance	± 2% (selectable from ± 1% to ± 5% from front panel)			
Standard equipment provided	Back Feed protection; separable bypass line			
<b>BYPASS</b>				
Nominal voltage	380 - 400 - 415 Vac three-phase + N			
Nominal frequency	50 or 60 Hz (selectable)			
<b>OUTPUT</b>				
Nominal power (kVA)	100	120	160	200
Active power (kW)	90	108	144	180
Number of phases	3 + N			
Nominal voltage	380 - 400 - 415 Vac three-phase + N (selectable)			
Static stability	± 1%			
Dynamic stability	± 5% in 10 ms			
Voltage distortion	< 1% with linear load / < 3% with non-linear load			
Crest factor	3:1 I <sub>peak</sub> /I <sub>rms</sub>			
Frequency stability on battery	0.05%			
Frequency	50 or 60 Hz (selectable)			
Overload	110% for 60 minutes; 125% for 10 minutes; 150% for 1 minute			
<b>BATTERIES</b>				
Type	VRLA AGM / GEL; NiCd; Supercaps; Li-ion; Flywheels			
Residual ripple voltage	< 1%			
Temperature compensation	-0.5 V/°C			
Typical charge current	0.2 x C10			
<b>INFO FOR INSTALLATION</b>				
Weight (kg)	600	610	690	790
Dimensions (WxDxH) (mm)	800 x 800 x 1900			
Remote signals	dry contacts			
Remote controls	ESD and bypass			
Communications	Double RS232 + dry contacts + 2 slots for communications interface			
Operating temperature	0 °C / +40 °C			
Relative humidity	<95% non-condensing			
Colour	Dark grey RAL 7016			
Noise level at 1 m (ECO Mode)	65 dBA		68 dBA	
IP rating	IP20			
Smart Active efficiency	up to 98%			
Standards	Directives LV 2006/95/EC - 2004/108/EC; Safety IEC EN 62040-1; EMC IEC EN 62040-2; Performance IEC EN 62040-3			
Classification in accordance with IEC 62040-3	(Voltage Frequency Independent) VFI - SS - 111			
Moving the UPS	Pallet Jack			







# Master HP



DATACENTRE



E-MEDICAL



INDUSTRY



TRANSPORT



EMERGENCY



ONLINE



Tower



**3:3** 100-600 kVA



SmartGrid ready



Flywheel compatible



Supercaps UPS



Service 1st start



## HIGHLIGHTS

- IGBT-based rectifier technology
- Compact and reliable
- Galvanic isolation
- High overload capacity
- LCD graphic display

The Master HP series from 100 to 600 kVA is the Riello UPS solution for installations requiring high energy efficiency and maximum power availability. Master HP Series provides maximum protection and power quality for data centres and industrial loads. The UPS has an IGBT-based rectifier, DSP (Digital Signal Processors) technology and provides true On-line, double conversion power protection, (VFI SS 11 - Voltage and Frequency Independent in accordance with IEC EN 62040-3).

## Maximised cost savings

The Master HP has the ability to monitor the mains input quality and to select the best operating mode based on the interference present (Smart Active mode) or circular redundancy (Parallel Energy Saving mode, which allows the UPS to regulate available capacity based on the immediate demands of the load, automatically switching to standby in the event of excess capacity), the Master HP also offers high levels of efficiency for partial loads, resulting in reduced operating costs.

## Power continuity

For years, Riello UPS has developed and supplied solutions for dealing with the different requirements and problems that inevitably arise in critical applications. Riello UPS offers flexible, high-availability solutions that are able to adapt to different system structures and critical levels. Riello UPS creates UPS systems that can tolerate a number of component or subsystem failures, while continuing to operate normally, providing power without interruption. This is achieved by careful design, installing redundant elements, eliminating common failure points, scheduling maintenance activities and controlling and supervising the system operating parameters and environment. The TEC service team is ready to provide guidance and advice on projects.

## Main features

- High efficiency (up to 98.5%)
- Compact size: e.g.: only 0.85 m<sup>2</sup> for the Master HP 250 kVA
- Reduced weight
- Double load protection, both electronic and galvanic, towards the battery.

The entire Master HP range is suitable for use in a wide range of applications. Thanks to the flexibility of configuration, available options and accessories, it is suitable for supplying any type of load, e.g. capacitive loads such as blade servers etc. Power supply reliability and availability are ensured for critical applications by distributed or centralised parallel configurations of up to 8 units, for redundant (N+1) or power parallel configurations and all the different configurations offered by the Master MPS range.

## Zero impact source

Master HP has a zero impact on connected power sources - grid networks or generators:

- ≤ 3% input current distortion
- Input power factor 0.99
- power walk-in function - to ensure a progressive rectifier start-up
- start-up delay function - to restart the rectifier when the mains power supply is restored.

## Battery care system

Master HP series UPS include a range of features designed to prolong battery life and reduce their usage.

## Output isolation transformer

- Better load protection from DC/Battery problems
- The UPS can be supplied from 2 independent lines
- Fault on DC bus will not affect the bypass availability



- High Short circuit current
- Higher immunity to harmonics or energy backfeed generated by the load.

## Advanced supervision

Master HP series UPS have a front panel mounted graphic display providing UPS information, measurements, status updates and alarms in different languages, with wave form displays including voltage/current and providing a kWh reading that can be used to measure IT loads and calculate a datacentre PUE (Power Usage Effectiveness) ratio.

## Smart Grid Ready

Being Smart Grid Ready, Master HP allows for the implementation of power accumulation solutions, and at the same time ensures extremely high levels of efficiency. It is also able to independently select the most efficient operating method based on the status of the grid. Master HP UPS are also able to electronically interface with the energy manager using the smart grid communication network.



## DIMENSIONS

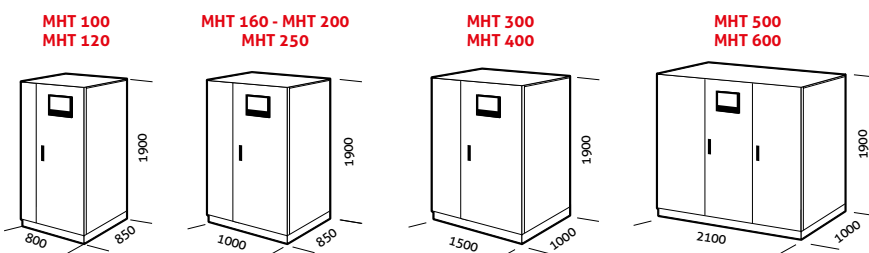

## OPTIONS

### SOFTWARE

PowerShield<sup>3</sup>  
PowerNetGuard

### ACCESSORIES

NETMAN 204  
MULTICOM 302  
MULTICOM 352  
MULTI I/O  
MULTIPANEL

### PRODUCT ACCESSORIES

Isolation transformer  
Synchronisation device (UGS):  
*see Master MPS on page 88*  
Hot connection device (PSJ):  
*see Master MPS on page 88*  
Digital I/O and Generator interface  
Parallel configuration kit (Closed Loop)  
Battery cabinets empty or for  
extended runtimes  
Top Cable Entry cabinets  
IP rating IP31/IP42

## DETAILS

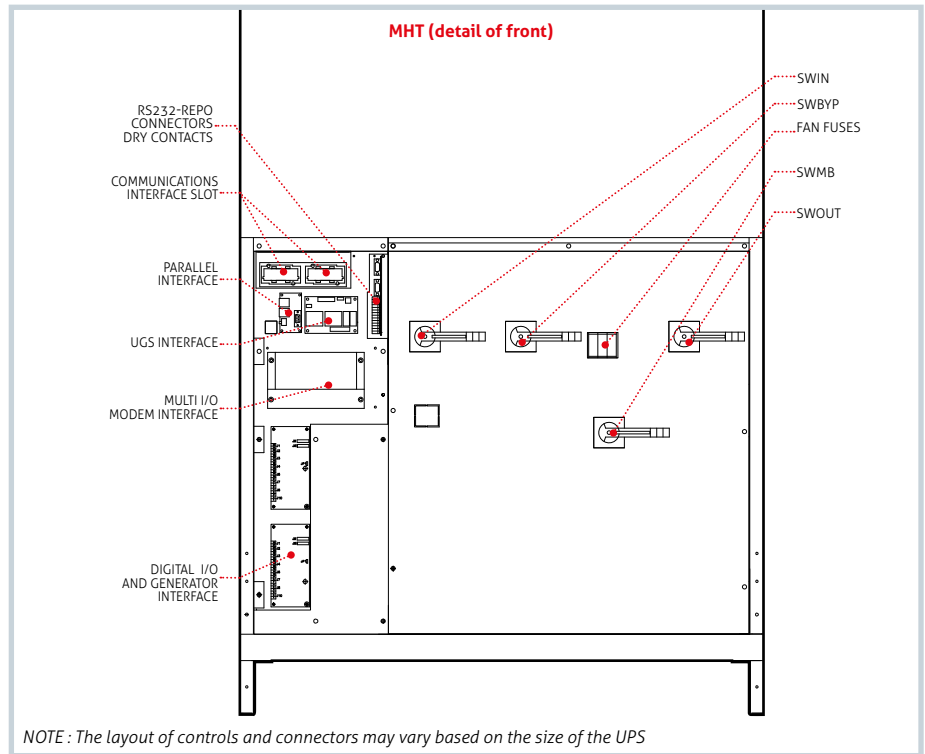

## BATTERY BOX

### MODELS

BB 1900 480-V6 / BB 1900 480-V7  
BB 1900 480-V8 / BB 1900 480-V9

### UPS MODELS

MHT 100-600

Dimensions  
(mm)

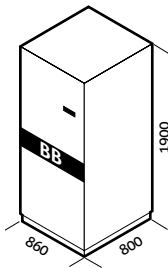

## CABINETS WITH TOP ACCESS FOR CABLES

### MODELS

TCE MHT 100-250

TCE MHT 300-600

### UPS MODELS

MHT 100-250

MHT 300-600

Dimensions  
(mm)

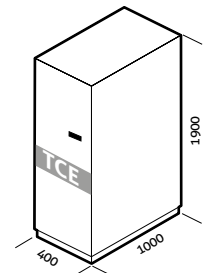
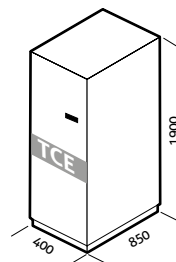

## THREE-PHASE ISOLATION TRANSFORMERS

### MODELS

TBX 100 T - TBX 160 T

TBX 200 T - TBX 250 T

TBX 300 T - TBX 600 T

### UPS MODELS

MPT 100-160 / MHT 100-160

MPT 200 / MHT 200-250

MHT 300-600

Dimensions  
(mm)

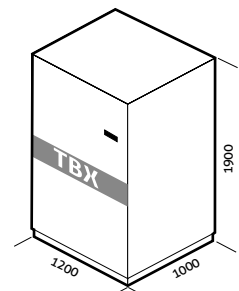
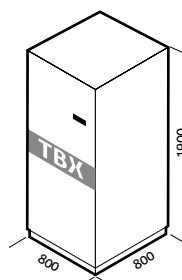
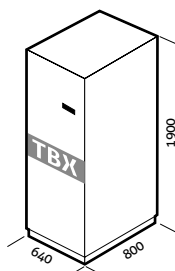



MODELS	MHT 100	MHT 120	MHT 160	MHT 200	MHT 250	MHT 300	MHT 400	MHT 500	MHT 600
<b>INPUT</b>									
Nominal voltage	380 - 400 - 415 Vac three-phase								
Voltage tolerance	400 V ± 20% @ full load								
Frequency	45 - 65 Hz								
Power factor	> 0.99								
Harmonic current distortion	<3% THDi								
Soft start	0 - 100% in 120" (selectable)								
Frequency tolerance	± 2% (selectable from ± 1% to ± 5% from front panel)								
Standard equipment provided	Back Feed protection; separable bypass line								
<b>BYPASS</b>									
Nominal voltage	380 - 400 - 415 Vac three-phase + N								
Nominal frequency	50 or 60 Hz (selectable)								
<b>OUTPUT</b>									
Nominal power (kVA)	100	120	160	200	250	300	400	500	600
Active power (kW)	90	108	144	180	225	270	360	450	540
Number of phases	3 + N								
Nominal voltage	380 - 400 - 415 Vac three-phase + N (selectable)								
Static stability	± 1%								
Dynamic stability	± 5% in 10 ms								
Voltage distortion	< 1% with linear load / < 3% with non-linear load								
Crest factor	3:1 lpeak/lrms								
Frequency stability on battery	0.05%								
Frequency	50 or 60 Hz (selectable)								
Overload	110% for 60 minutes; 125% for 10 minutes; 150% for 1 minute								
<b>BATTERIES</b>									
Type	VRLA AGM / GEL; NiCd; Supercaps; Li-ion; Flywheels								
Ripple current	Zero								
Recharge voltage compensation	-0.5 Vx°C								
<b>INFO FOR INSTALLATION</b>									
Weight (kg)	656	700	800	910	1000	1400	1700	2100	2400
Dimensions (WxDxH) (mm)	800 x 850 x 1900		1000 x 850 x 1900			1500 x 1000 x 1900		2100 x 1000 x 1900	
Remote signals	dry contacts (configurable)								
Remote controls	ESD and bypass (configurable)								
Communications	Double RS232 + dry contacts + 2 slots for communications interface								
Operating temperature	0 °C / +40 °C								
Relative humidity	<90% non-condensing								
Colour	Dark grey RAL 7016								
Noise level at 1 m	63 - 68 dBA					70 - 72 dBA			
IP rating	IP20 (others on request)								
Smart Active efficiency	up to 98.5%								
Standards	Safety: EN 62040-1-1 (Directive 2006/95/EC); EMC: EN 62040-2 (Directive 2004/108/EC)								
Classification in accordance with IEC 62040-3	(Voltage Frequency Independent) VFI - SS - 111								
Moving the UPS	Pallet Jack								

# Master HE



DATACENTRE



E-MEDICAL



INDUSTRY



TRANSPORT



EMERGENCY



ONLINE



Tower



**3:3** 100-800 kVA



SmartGrid  
ready



Flywheel  
compatible



Supercaps  
UPS



Service  
1st start

## HIGHLIGHTS

- **High efficiency**  
up to 95.5% in on-line mode
- **kW = kVA (pf 1)**  
10-40 °C no downgrading
- **Rectifier IGBT based technology**
- **Galvanic isolation**
- **High overload capacity**
- **LCD Display**

## HE - High Efficiency

Master HE series is available from 100 to 800 kVA. The UPS features a new on-line double-conversion technology utilising IGBT and DSP (Digital Signal Processor) control to provide maximum protection, power quality and green energy for any type of application including datacentres, disaster recover sites, telecoms rooms, industrial processes and security applications.

High efficiency stands for higher active power available if compared with legacy UPS thanks to output unitary power factor (up to +25% if compared unity with same UPS at p.f. 0.8). Nominal power is granted with no downgrading independently from operating temperature in the range 10-40°C.

Furthermore, control circuits and specifically designed firmware grant outstanding online double conversion efficiency up to 95,5%, comparable with the best transformeless UPS available on the market.

## Maximised cost savings

The build specifications offered by the Master HE range and the exceptional level of efficiency help to absorb the TCO, from the installation stage to daily operation, reducing power costs for the UPS, air conditioning system and installation area costs thanks to its reduced size and weight.

## Complete galvanic separation

Master HE UPS feature an output isolation transformer (delta zig/zag type) on the inverter as part of the inverter circuit inside the UPS cabinet, providing galvanic isolation between the load and the battery with improved versatility in system configuration, allowing:

- Complete UPS output galvanic isolation for critical infrastructures from the battery DC power source;
- two truly separated supply inputs (main and bypass), which can be taken from two different power sources (with different neutrals); this is particularly well suited to parallel systems in order to ensure selectivity between the two sources, thus improving the reliability of the entire installation;
- No neutral input connection is required at the UPS rectifier input stage; this method is particularly favourable in order to prevent the transmission of common neutral disturbances via the neutral conductor;
- No effects to the UPS output performance or reduced impact of the inverter power components whilst supplying specific loads; in addition the inverter transformer minimizes the impact of third harmonic disturbances, prevents the effects of energy back-feed into the inverter when supplying industrial load applications and can supply unbalanced loads.
- High inverter short circuit current to clear faults which occur between phase and neutral on load side (up to three times nominal current).

Output transformer housed within the cabinet which allows for a significant reduction in the footprint and provides space savings.

## Zero impact source

The Master HE series features the added advantages of the Zero Impact Source formula offered by an IGBT-based rectifier assembly. This eliminates problems connected with installation in networks with limited power capacity, where the UPS is supplied by a generator set or anywhere there are compatibility problems with loads that generate current harmonics. Master HE series UPS have zero impact on the power supply source, whether it is a mains grid or generator set:

- input current distortion < 3%
- input power factor 0.99
- power walk-in function that ensures progressive rectifier start up
- start-up delay function, to restart the rectifiers when mains power is restored if there are several UPS in the system.

This provides savings in installation costs via:

- a smaller electrical infrastructure.
- smaller circuit protection devices
- less wiring.

Master HE also performs the role of a filter and power factor corrector, protecting the upstream power supply from any harmonics and reactive power generated by the critical load.

## Flexibility

Master HE is suitable for a wide range of applications including IT and the most demanding industrial environments and processes. With several operational configurations including On-Line, Eco, Smart Active, Stand By, Frequency Converter and Voltage Stabiliser. A broad range of accessories and options, complex configurations and system architectures can be achieved to guarantee maximum power availability and the option to add new UPS without interruption to existing users. Using the Riello UPS Group Synchroniser (UGS) and Parallel Systems Joiner (PSJ), sophisticated inter group parallel and redundant systems can be achieved to provide the highest possible levels of resilience and availability.

## Specific solutions

The UPS can be adapted to meet your requirements. Contact our TEC team to discuss specific solutions and options not listed in this catalogue.

## Battery care system: maximum battery care

Master HE series UPS include a range of features designed to prolong battery life and reduce their usage such as different recharging methods, deep discharge protection, current limitation and voltage compensation according with battery room temperature.

Thanks to the STEP-UP/STEP-DOWN converter, that provides to recharge and discharge the battery, the current ripple

in the battery is extremely reduced; this arrangement enhance the battery reliability since it is no longer connected to UPS DC bus.

## Main features

- High efficiency up to 99.4% (stand by on mode)
- Compact size: e.g.: only 0.85 m<sup>2</sup> for the Master HE 250 kVA
- Reduced weight for transformer based UPS
- Double load protection, both electronic and galvanic, towards the battery.

The entire Master HE range is suitable for use in a wide range of applications. Thanks to the flexibility of configuration, available options and accessories, it is suitable for supplying any type of load, e.g. capacitive loads such as blade servers, rather than motor drivers or any other critical vertical application.

Power supply reliability and availability are ensured for critical applications by distributed or centralised parallel configurations of up to 8 units, for redundant (N+1) or power parallel configurations and all the different configurations offered by the Master MPS range.

## Smart Grid Ready

Being smart grid ready, Master HE allows for the implementation of power accumulation solutions, and at the same time ensures extremely high levels of efficiency. It is also able to independently select the most efficient operating method based on the status of the grid. Master HE UPS are also able to electronically interface with the energy manager using the smart grid communication network.

## Advanced supervision

Master HE series UPS have a front panel graphic display providing UPS information, measurements, status updates and alarms in different languages, with wave form displays including voltage/current and provide a kWh reading that can be used to measure IT loads and calculate a datacentre PUE (power usage effectiveness) ratio.

## DIMENSIONS

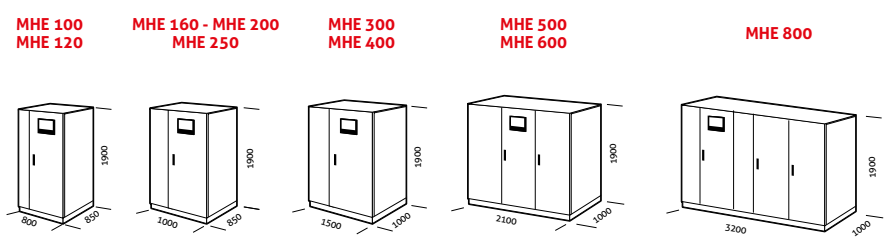

## OPTIONS

### SOFTWARE

PowerShield<sup>3</sup>  
PowerNetGuard

### ACCESSORIES

NETMAN 204  
MULTICOM 302  
MULTICOM 352  
MULTI I/O  
MULTIPANEL

### PRODUCT ACCESSORIES

Isolation transformer  
Synchronisation device (UGS):  
*see Master MPS on page 88*  
Hot connection device (PSJ):  
*see Master MPS on page 88*  
Digital I/O and Generator interface  
Parallel configuration kit (Closed Loop)  
Battery cabinets empty or for  
extended runtimes  
Top Cable Entry cabinets  
IP rating IP31/IP42

## DETAILS

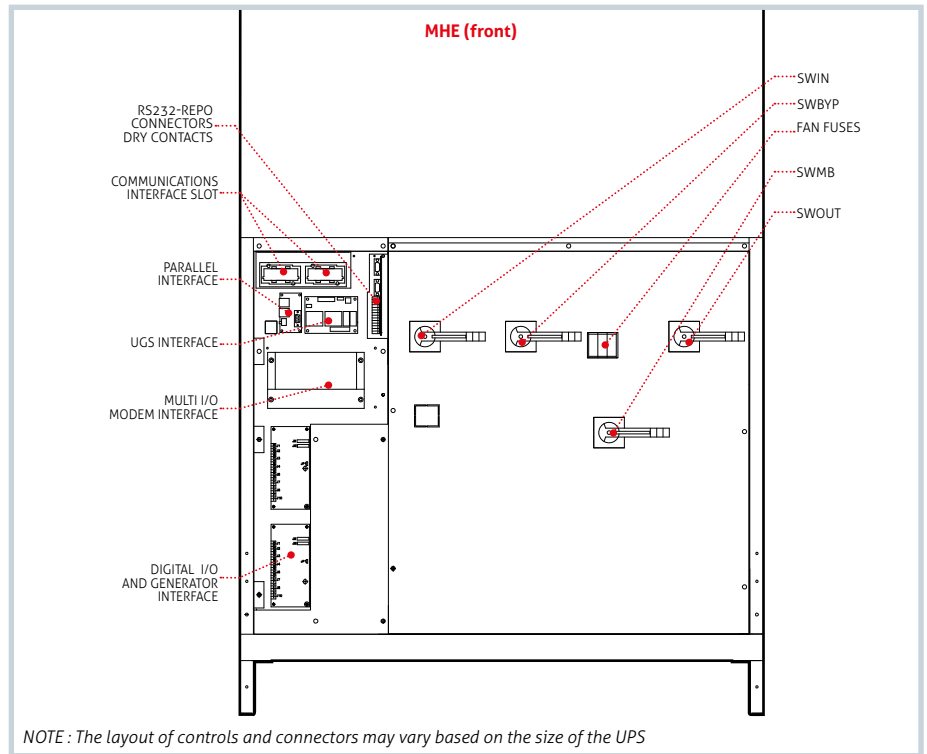

## BATTERY BOX

### MODELS

BB 1900 480-V6 / BB 1900 480-V7  
BB 1900 480-V8 / BB 1900 480-V9

### UPS MODELS

MHE 100-800

Dimensions  
(mm)

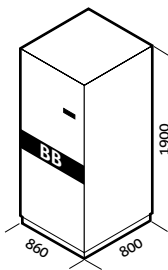

## CABINETS WITH TOP ACCESS FOR CABLES

### MODELS

TCE MHT 100-250

TCE MHT 300-600

### UPS MODELS

MHE 100-250

MHE 300-600

Dimensions  
(mm)

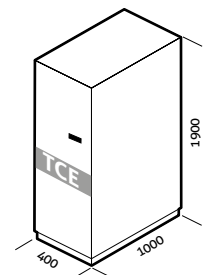
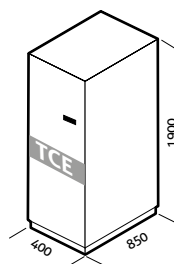

## THREE-PHASE ISOLATION TRANSFORMERS

### MODELS

TBX 100 T - TBX 160 T

TBX 200 T - TBX 250 T

TBX 300 T - TBX 600 T

### UPS MODELS

MPT 100-160 / MHE 100-160

MPT 200 / MHE 200-250

MHE 300-600

Dimensions  
(mm)

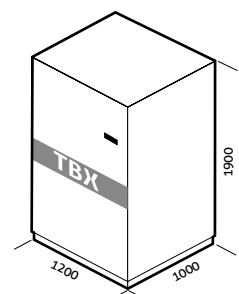
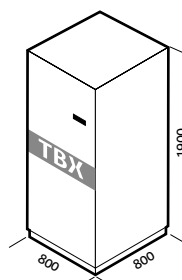
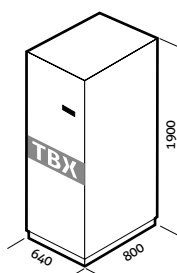



MODELS	MHE 100	MHE 120	MHE 160	MHE 200	MHE 250	MHE 300	MHE 400	MHE 500	MHE 600	MHE 800
<b>INPUT</b>										
Nominal voltage	380 - 400 - 415 Vac 3-phase									
Voltage tolerance	400 V ± 20% @ full load									
Frequency	45 - 65 Hz									
Power factor	> 0.99									
Harmonic current distortion	<3% THDi									
Soft start	0 - 100% in 120" (selectable)									
Frequency tolerance	± 2% (selectable from ± 1% to ± 5% from front panel)									
Standard equipment	Back Feed protection; separable bypass line									
<b>BYPASS</b>										
Nominal voltage	380 - 400 - 415 Vac 3-phase + N									
Frequency	50 or 60 Hz selectable									
<b>OUTPUT</b>										
Nominal power (kVA)	100	120	160	200	250	300	400	500	600	800
Active power (kW)	100	120	160	200	250	300	400	500	600	800
Number of phases	3 + N									
Nominal voltage	380 - 400 - 415 Vac 3-phase + N (selectable)									
Static stability	± 1%									
Dynamic stability	± 5% in 10 ms									
Voltage distortion	< 1% with linear load / < 3% with non-linear load									
Crest factor (I <sub>peak</sub> /I <sub>rms</sub> )	3:1									
Frequency stability on battery	0.05%									
Frequency	50 or 60 Hz (selectable)									
Overload	110% for 60 minutes; 125% for 10 minutes; 150% for 1 minute									
<b>BATTERIES</b>										
Type	VRLA AGM / GEL; NiCd; Supercaps; Li-ion; Flywheels									
Ripple current	Zero									
Charge voltage compensation	-0.5 Vx°C									
<b>INFO FOR INSTALLATION</b>										
Weight (kg)	730	785	865	990	1090	1520	1670	2500	2830	3950
Dimensions (WxDxH) (mm)	800 x 850 x 1900		1000 x 850 x 1900			1500 x 1000 x 1900		2100 x 1000 x 1900		3200 x 1000 x 1900
Remote signals	volt-free contacts (configurable)									
Remote controls	ESD and bypass (configurable)									
Communication	Double RS232 + remote contacts + 2 slots for communications interface									
Ambient temperature	0 °C / +40 °C									
Relative humidity	< 90% non-condensing									
Colour	Dark grey RAL 7016									
Noise level (@ 1 m)	63 - 68 dBA					70 - 72 dBA				
Protection level	IP20 (others upon request)									
Smart Active Efficiency	> 99%									
Double Conversion Efficiency	up to 95.5%									
Regulations	Safety: EN 62040-1 (directive 2006/95/EC); EMC: EN 62040-2 (directive 2004/108/EC)									
Classification according to IEC 62040-3	(Voltage Frequency Independent) VFI - SS - 111									



DATACENTRE



INDUSTRY



TRANSPORT

# Master Static Bypass



Tower

**3:3** 800-3000 kVA



Service  
1st start

## HIGHLIGHTS

- Flexibility
- The ideal solution for installations with UPS in parallel greater than 1 MVA
- High system reliability
- Centralised diagnostics

The centralised bypass is an alternative to the distributed bypass. Technically the two solutions fulfil the same purpose, i.e. to guarantee power continuity, but have different architectures.

Whilst it is true that distributed bypass solutions are the most common due to their flexibility of use and low initial cost, it is also true that in the medium/large data centre market centralised bypass solutions are preferable in terms of technical performance, footprint and sometimes cost, above all in large installations where the number and type of protections as well as system wiring have an impact. The data centre and data-storage market in general is destined for large growth. It is therefore important to respond to the

various requirements with flexible solutions that are able to adapt to the growing demands of the market in terms of the levels of power and performance required.

### Flexibility

The Riello UPS centralised bypass (named MSB) is available in four standard power ratings: 800, 1200, 2000 and 3000 kVA. Intermediate solutions within this range can be made, as well as solutions greater than 3000 kVA based on the requirements of the customer or application. The MSB centralised bypass can be integrated with the Master HP range; in fact it can be associated with up to 7 UPS modules in the range, obviously without static bypass and associated bypass line

(named MHU). Based on requirements, MSB can also be compatible with the Master MPS range, thus ensuring complete flexibility aimed at satisfying all power and power supply requirements.

Riello UPS provides the same flexibility as the Master HP for the battery bus, so that the MHU units can operate with both shared or separate batteries.

The 800 kVA MSB is supplied with a comprehensive cabinet including bypass line input switch (SWBY), system output switch (SWOUT) and manual bypass (SWMB). The 1200 kVA model is supplied as standard without any switches but can be equipped with the same, suitably proportioned, switches provided for the 800 kVA model (SWBY, SWOUT, SWMB).

The more powerful models are supplied with no switches; the bulky sizes of disconnection devices at these power levels are such as to favour tailor-made engineering solutions as an additional part of the system attestation and distribution cabinets where the centralised bypass and MHU modules are fitted.

### The ideal solution for installations with UPS in parallel greater than 1 MVA

Medium-high power systems are often comprised of N UPS of small-medium power ratings arranged in parallel. It is clear that the larger the size of the individual UPS modules or the number of units configured in parallel, the more complex and extensive the system wiring shall be. Particular attention should be paid to the length of the power lines for the individual UPS

bypasses, so that they are equidistant from the common points. Even minimal variations in the line impedances of the individual bypasses can cause current equipartition problems between the UPS and associated overcurrent in the cables whenever they supply from the bypass. This can lead to the inappropriate cut-in of protection devices and can generate heat, with the end result of minimising power continuity and increasing power consumption for cooling the system. The Riello UPS centralised bypass (MSB) is the ideal solution for eliminating all critical issues connected with power distribution over bypass lines. When activated, all power flows through a single static bypass module, ensuring:

- High reliability
- Improved energy efficiency
- Exceptional ability to withstand short-circuits downstream of the system
- Centralised system control both with regards to accessibility to system information and with regards to manoeuvrability since the system is equipped with a single manual system bypass.

By opting for the solution with a centralised bypass, the individual MHU units are provided without integrated static bypasses, thus eliminating critical components (static circuit and associated line protections such as disconnectors and/or fuses). This translates into a lower installation cost by eliminating the cables for the auxiliary power supply lines to the individual modules.

These advantages grow exponentially as the power levels at play and number of modules

increase. This is why the centralised bypass solution is technically and economically preferable for power levels above one megawatt.

### High system reliability

When compared to a solution with a distributed bypass and a considerable number of UPS modules arranged in parallel (more than 4), the MSB solution significantly reduces the amount of components (SCR, switches, control elements for individual static bypasses, coupling inductances), consequently increasing system reliability.

### Power supply from bypass line: "On Line" mode

Recent design philosophies for data centres are pushing towards making systems operate on bypass lines not only in the event of an emergency, but as an alternative to "ON-Line" mode, thus improving system efficiency. For this reason power circulation through a single line (centralised bypass), eliminates all problems connected with current distribution, which must be ensured in the event of the operation of UPS modules in parallel with distributed by-passes. The greater the power rating of the UPS, the exponentially greater the risk of minimal impedance differences in the bypass lines generating large imbalances in current circulation, with a serious risk of protection cut-in, compromising power supply continuity. With the centralised bypass the static circuit is single and independent and the current flows through a single channel, ensuring immunity from interaction problems between individual UPS units.

#### PARALLEL CONFIGURATION OF UP TO 8 UPS UNITS WITH DISTRIBUTED BYPASS

Parallel architecture to ensure redundancy of the power source.  
**+ Flexibility and modularity and no single point of failure.**

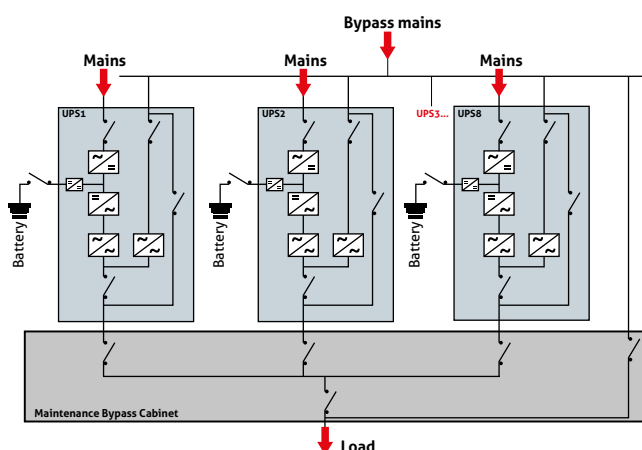

#### PARALLEL CONFIGURATION OF UP TO 7 MHU UNITS WITH CENTRALISED BYPASS

Parallel architecture to ensure redundancy of the power source, with autonomous bypass management.  
**+ Selectivity of downstream faults in bypass mode**

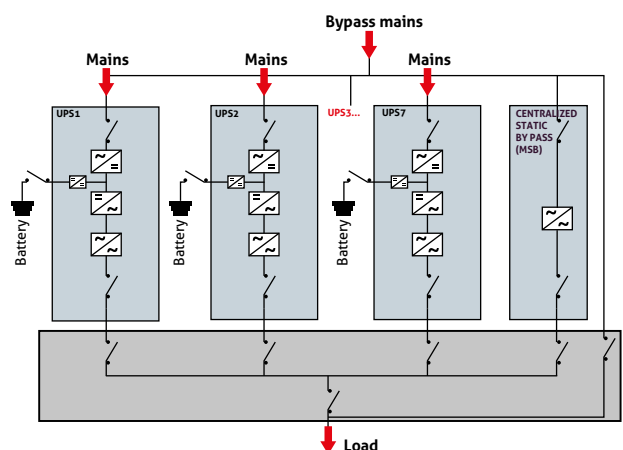

## Power supply from bypass line: in an emergency

The static bypass is a support device aimed at ensuring power continuity in the event of inverter failure. In the event of N UPS configured in parallel the failure of a single inverter module should automatically exclude it from the parallel system, ensuring the correct operation of the other units and the reliability of the system.

For this reason automatic switching to bypass lines takes place only when there is a serious fault with the inverter or due to external forces, such as a short circuit downstream of the system. These events are both rapid and unpredictable and, based on the power available on the line, can generate short circuit currents that can be extremely high. In the event of distributed parallel configurations where N static by-passes are arranged in parallel, minimal differences (even in the order of fractions of a millisecond), can generate uncontrolled transients and current flow between UPS units such as to trigger protection devices or

even damage the bypass thyristors. Riello UPS are equipped with sophisticated parallel control logics that ensure synchronism between the various units arranged in parallel under all operating conditions. The Riello MSB centralised bypass in any case ensures complete immunity from any problem connected with switching synchronism between modules even in the most extreme cases as long as the static module is single and independent. In addition, differently from a distributed parallel configuration of the same power rating, the centralised bypass can be oversized to guarantee increased overload capacity and the ability to withstand short circuits. The ventilation system for the MSB static bypass is designed to guarantee operation even in the event of the failure of several fans. In order to constantly monitor the status of the fans, a control circuit can be provided to control the operation of each individual ventilation fan.

## Centralised diagnostics

The use of the MSB centralised bypass centralises the diagnostics and control of the bypass line. The display provides information concerning the voltage and current supplied and the status of the individual UPS modules (MHU). Differently from a system with distributed bypass, the centralised bypass is equipped with a single disconnection device for the bypass line and can be provided with an integrated manual bypass. The single disconnection device guarantees that the manoeuvres are carried out quickly and with a minimum margin of error, guaranteeing once again improved system reliability. The MSB bypass provides dedicated housings for the various remote control systems such as: three-contact relay board (standard), two communications slots and full compatibility with the communications interfaces in the Riello UPS range for UPS in the MHT / MPT ranges.

## OPTIONS

### SOFTWARE

PowerShield<sup>3</sup>  
PowerNetGuard

### ACCESSORIES

NETMAN 204  
MULTICOM 302  
MULTICOM 352  
MULTI I/O  
MULTIPANEL

### PRODUCT ACCESSORIES

Top Cable Entry cabinets  
IP rating IP31/IP42  
Manoeuvring switches  
Digital I/O and Generator interface

## DETAILS

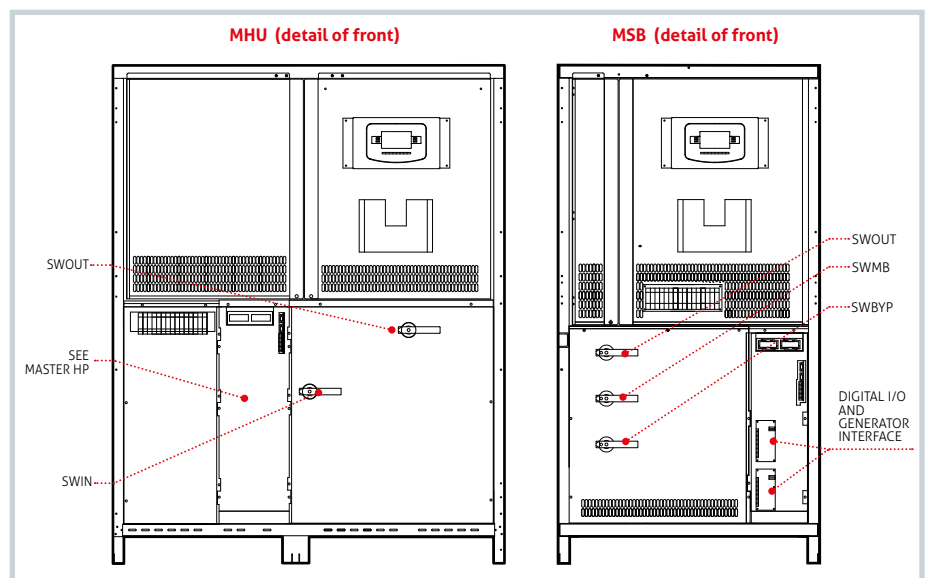

## DIMENSIONS

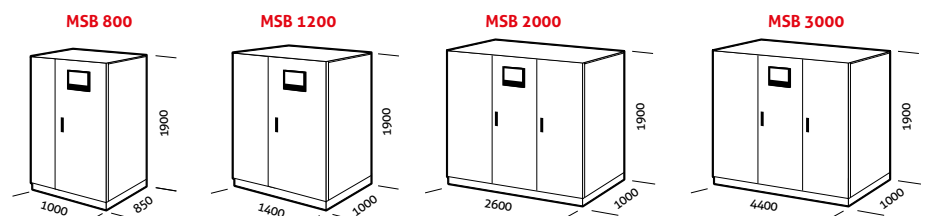



MODELS	MSB 800	MSB 1200	MSB 2000	MSB 3000
<b>OPERATING SPECIFICATIONS</b>				
Nominal power (kVA)	800	1200	2000	3000
Nominal voltage	380 - 400 - 415 Vac three-phase + N			
Voltage tolerance	± 15% (selectable from ± 10% to ± 25% from front panel)			
Frequency	50/60 Hz			
Frequency tolerance	± 2% (selectable from ± 1% to ± 6% from front panel)			
Standard equipment provided	Back Feed protection			
Permitted overload*	110% for 60 minutes; 125% for 10 minutes; 150% for 1 minute			
<b>ENVIRONMENTAL SPECIFICATIONS</b>				
Noise at 1 m from front (from 0 to full load)	< 65 dBA			
Storage temperature	-10 °C up to +50 °C			
Operating temperature	0 °C - 40 °C			
Relative humidity	90% non-condensing			
Max. installation height	1000 m at nominal power (-1% power for every 100 m above 1000 m) - Max 4000 m			
Reference standard	EN 62040-1 general safety requirements; IEC 62040-2 electromagnetic compatibility			
<b>INFO FOR INSTALLATION</b>				
Weight (kg)	570	800	1200	2400
Dimensions (WxDxH) (mm)	1000 x 850 x 1900	** 1400 x 1000 x 1900	2600 x 1000 x 1900	4400 x 1000 x 1900
Communications	Double RS232 + dry contacts + 2 slots for communications interface			
Colour	Dark grey RAL 7016			
IP rating	IP20 (others on request)			
Moving the UPS	Pallet Jack			

\* under certain conditions    \*\* 1800 mm version with switches

# Master HP UL



DATACENTRE



E-MEDICAL



INDUSTRY



TRANSPORT



EMERGENCY



ONLINE



Tower



**3:3** 65-500 kVA



Service  
1st start



UL certified



SmartGrid  
ready

## HIGHLIGHTS

- High efficiency
- IGBT-based rectifier technology
- Compact, reliable and robust
- Galvanic isolation
- High overload capacity

The high levels of quality, reliability and energy savings offered by the Master HP range of UPS, has been extended to include a UL/CSA Listed, 480 Vac 60 Hz version with ratings from 65 kVA to 500 kVA.

IT managers, facility managers, and CTOs are under increasing pressure to reduce downtime and assure that their critical loads are supplied with uninterrupted and high quality power. With this increasingly stringent requirement, Riello UPS has invested in power solutions that meet strict demands; a commitment resulting in the launch of the Master HP UL range.

More than just an innovative and technologically-advanced UPS, it is a leap into the future of three-phase technology. With its double conversion on-line

technology based entirely on IGBT and digital signal processors (DSP), the Master HP UL range ensures maximum critical load protection, with VFI SS 111 classification (Voltage and Frequency Independent) in accordance with IEC EN 62040-3.

This range is designed using a new configuration that includes an IGBT sinusoidal input rectifier. Unique in its design, double conversion technology with galvanic isolated output guarantees a quality power supply that is completely protected from all electrical anomalies at the input.

### Complete galvanic separation

The Master HP UL UPS features an output isolation transformer on the inverter as part of the inverter circuit inside the UPS cabinet,

providing galvanic isolation between the load and the battery with improved versatility in system configuration, allowing:

- Complete UPS output galvanic isolation for critical infrastructures from the battery DC power source;
- Two truly separated supply inputs (utility and bypass), which can be taken from two different power sources (with different neutrals); this is particularly well suited for parallel systems in order to ensure selectivity between the two sources, improving the reliability of the entire installation;
- No neutral input connection is required at the UPS rectifier input stage; this method is particularly favorable in order to prevent the transmission of common neutral disturbances via the neutral conductor;
- No effects to the UPS output performance or reduced impact of the inverter power components while supplying specific loads; in addition the inverter transformer minimizes the impact of third harmonic disturbances, prevents the effects of energy back-feed into the inverter when supplying industrial load applications and can supply unbalanced loads.
- High inverter short circuit current to clear faults which occur between phase and neutral on load side (up to three times nominal current).

Output transformer housed within a cabinet which allows for a significant reduction in the footprint and provides space savings.

### Zero impact source

The Master HP UL series features the added advantages of the Zero Impact Source formula offered by an IGBT-based rectifier assembly. This eliminates problems connected with installation in networks with limited power capacity, where the UPS is supplied by a generator set or anywhere there are compatibility problems with loads

that generate current harmonics. Master MHT UL series UPS have zero impact on the power supply source, whether it is a utility grid or generator set:

- Input current distortion < 3%
- Input power factor 0.99
- Power walk-in function that ensures progressive rectifier start up
- Start-up delay function, to restart the rectifiers when mains power is restored if there are several UPS in the system.

This provides savings in installation costs via:

- A smaller electrical infrastructure.
- Smaller circuit protection devices
- Less wiring.

### Flexibility

Master HP UL is suitable for a wide range of applications including IT and the most demanding industrial environments and processes. With several operational configurations including On-Line, Eco, Smart Active, Stand By, Frequency Converter and Voltage Regulation. A broad range of accessories and options, complex configurations and system architectures can be achieved to guarantee maximum power availability and the option to add new UPS without interruption to site operations.

### Battery care system: maximum battery care

Master HP UL series UPS include a range of features designed to prolong battery life and reduce usage by using different recharging methods; deep discharge protection, current limitation, and voltage compensation based on ambient temperature.

### Main features

- Compact size: e.g.: only 2.330 square inches for the Master HP UL 500 kVA
- Reduced weight for transformer based UPS
- Double load protection, both electronic and galvanic, towards the battery.

The entire Master HP UL range is suitable for use in a wide range of applications. The Master HP can supply any type of load, e.g. servers, controls, lighting, capacitive, switch mode. Power supply reliability and availability are ensured for critical applications by distributed parallel configurations of up to 8 units, for redundant (N+1) or power parallel configurations.

### Advanced supervision

The Master HP UPS has a front panel mounted graphic display providing UPS information, measurements, status updates and alarms in multiple languages, with waveform displays including voltage/current and providing a kWh reading that can be used to measure IT loads and calculate a Data Centre PUE (Power Usage Effectiveness) ratio.

## OPTIONS

#### SOFTWARE

PowerShield<sup>3</sup>  
PowerNetGuard

#### ACCESSORIES

NETMAN 204  
Multi I/O (Relay Alarm card and generator Interface)

#### PRODUCT ACCESSORIES

Parallel configuration kit (Closed Loop)  
Fully configured battery systems with appropriate autonomy  
Maintenance Bypass Switchgear for all models

## DIMENSIONS

**MHT 65 UL**  
**MHT 80 UL**  
**MHT 100 UL**  
**MHT 125 UL**

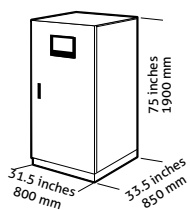

including manual bypass

**MHT 160 UL**  
**MHT 200 UL**  
**MHT 250 UL**

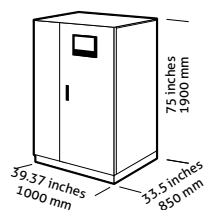

excluding manual bypass

**MHT 160 UL**  
**MHT 200 UL**  
**MHT 250 UL**

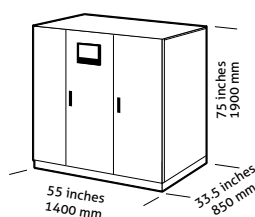

including manual bypass  
Top Cable Entry cabinets

**MHT 300 UL**  
**MHT 400 UL**  
**MHT 500 UL**

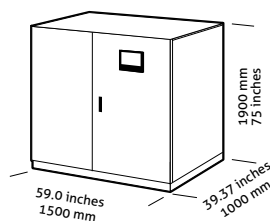

**MHT 300 UL TCE**  
**MHT 400 UL TCE**  
**MHT 500 UL TCE**

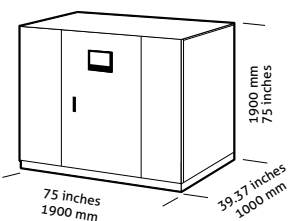

MODELS	MHT 65 UL	MHT 80 UL	MHT 100 UL	MHT 125 UL	MHT 160 UL
<b>INPUT</b>					
Nominal voltage	480 Vac three-phase + N				
Frequency	45 - 65 Hz				
Power factor	> 0.99				
Harmonic current distortion	<3% THDi				
Soft start	0 - 100% in 125" (selectable)				
Frequency tolerance	± 2% (selectable from ± 1% to ± 5% from front panel)				
Standard equipment provided	Back Feed protection; separable bypass line				
<b>BATTERIES</b>					
Type	VRLA, Wet Cell, NiCd				
Ripple current	Zero				
Recharge voltage compensation	-0.5 Vx°C				
<b>OUTPUT</b>					
Nominal power (kVA)	65	80	100	125	160
Active power (kW)	58.5	72	90	112.5	144
Number of phases	3 + N				
Nominal voltage	480 Vac three-phase + N				
Static stability	± 1%				
Dynamic stability	from ± 5% to ± 1% in 20 ms				
Voltage distortion	< 1% with linear load / < 3% with non-linear load				
Crest factor	3:1 lpeak/lrms				
Frequency stability on battery	0.05%				
Frequency	60 Hz				
Overload	110% for 60 minutes; 125% for 10 minutes; 150% for 1 minute				
<b>INFO FOR INSTALLATION</b>					
Weight (lbs [kg])	1500 [680]		1610 [730]	1742 [790]	1851 [840]
Weight with TCE and Maintenance bypass (lbs [kg])	-	-	-	-	2204 [1000]
Dimensions (WxDxH) (inches [mm])	31.5 x 33.5 x 75 [800 x 850 x 1900]				39 x 33.5 x 75 [1000x850x1900]
Dimensions with TCE and Maintenance bypass (WxDxH) (inches [mm])	-	-	-	-	55 x 33.5 x 75 [1400x850x1900]
Remote signals	dry contacts (configurable)				
Remote controls	ESD and bypass (configurable)				
Communications	Double RS232 + dry contacts + 2 slots for communications interface with SNMP, Modbus, and Bacnet Protocols				
Operating temperature	0 °C / +40 °C (32 to 104 °F)				
Relative humidity	<95% non-condensing				
Color	Black				
Noise level at 1 m (ECO Mode)	65 dBA			68 dBA	
IP rating	IP20				
Smart Active efficiency	up to 98.5%				
Standards	UL Standard 1778: 2nd edition from 65 to 125 kVA, 5th edition from 160 to 250 kVA; From 160 to 250 kVA: UL 60950-1 1: Information Technology Equipment - Safety - Part 1: General Requirements National Electrical Code (NFPA-70); FCC Part 15 Subpart J class A - Radio Frequency; IEC 62040-3; UL 924 and OUST category - Emergency Lighting and power equipment				
Classification in accordance with IEC 62040-3	(Voltage Frequency Independent) VFI - SS - 111				
Transport	Pallet Jack				



MODELS	MHT 200 UL	MHT 250 UL	MHT 300 UL	MHT 400 UL	MHT 500 UL
<b>INPUT</b>					
Nominal voltage	480 Vac three-phase + N				
Frequency	45 - 65 Hz				
Power factor	> 0.99				
Harmonic current distortion	<3% THDi				
Soft start	0 - 100% in 125" (selectable)				
Frequency tolerance	± 2% (selectable from ± 1% to ± 5% from front panel)				
Standard equipment provided	Back Feed protection; separable bypass line				
<b>BATTERIES</b>					
Type	VRLA, Wet Cell, NiCd on Racks or Cabinet				
Ripple current	Zero				
Recharge voltage compensation	-0.5 Vx°C				
<b>OUTPUT</b>					
Nominal power (kVA)	200	250	300	400	500
Active power (kW)	180	225	300	400	450
Number of phases	3 + N				
Nominal voltage	480 Vac three-phase + N				
Static stability	± 1%				
Dynamic stability	from ± 5% to ± 1% in 20 ms				
Voltage distortion	< 1% with linear load / < 3% with non-linear load				
Crest factor	3:1 lpeak/lrms				
Frequency stability on battery	0.05%				
Frequency	60 Hz				
Overload	110% for 60 minutes; 125% for 10 minutes; 150% for 1 minute				
<b>INFO FOR INSTALLATION</b>					
Weight (lbs [kg])	2138 [970]	2247 [1110]	4190 [1900]	4741 [2150]	4741 [2150]
Weight with TCE and Maintenance bypass (lbs [kg])	2524 [1145]	2799 [1270]	4410 [2000] *	4961 [2250] *	4961 [2250] *
Dimensions (WxDxH) (inches [mm])	39 x 33.5 x 75 [1000 x 850 x 1900]		59 x 39.5 x 75 [1500 x 1000 x 1900]		
Dimensions with TCE and manual bypass (WxDxH) (inches [mm])	55 x 33.5 x 75 [1400 x 850 x 1900]		75 x 39.5 x 75 [1900 x 1000 x 1900] *		
Remote signals	dry contacts (configurable)				
Remote controls	ESD and bypass (configurable)				
Communications	Double RS232 + dry contacts + 2 slots for communications interface				
Operating temperature	0 °C / +40 °C (32 to 104 °F)				
Relative humidity	<95% non-condensing				
Color	Black				
Noise level at 1 m (ECO Mode)	68 dBA		72 dBA		
IP rating	IP20				
Smart Active efficiency	up to 98.5%				
Standards	UL Standard 1778: 5th edition; UL 60950-1 1: Information Technology Equipment - Safety - Part 1: General Requirements; National Electrical Code (NFPA-70); FCC Part 15 Subpart J class A - Radio Frequency; IEC 62040-3; UL 924 and OUST category - Emergency Lighting and power equipment		UL Standard 1778: 5th edition; National Electrical Code (NFPA-70); NEMA; CSA C22.2; ASME; FCC section 15 subsection J class A; IEC 62040-3;		
Classification in accordance with IEC 62040-3	(Voltage Frequency Independent) VFI - SS - 111				
Transport	Pallet Jack				

\* Maintenance Bypass Switch – on option.



INDUSTRY



TRANSPORT

# Master Industrial



ONLINE



Tower



**3:1** 30-80 kVA  
DC BUS 220 Vdc



Service  
1st start



## HIGHLIGHTS

- **Battery voltage: 220 Vdc**
- **Galvanic isolation of input and output**
- **High short-circuit current**
- **Redundant ventilation**

### Industrial application protection

Master Industrial series UPS provide maximum protection and power quality for any type of load, especially industrial applications, such as manufacturing and petrochemical processes, electrical distribution and power plants. Master Industrial is an on-line double conversion UPS (class VFI SS 111 in accordance with IEC EN 62040-3) with input and output isolation transformers.

### Industrial environment

Master Industrial is suited to the most demanding installation environments where there are vibrations, mechanical stresses, dust

and in general where operating conditions are unfavourable to products created for the standard UPS market.

### High ICC

The high short-circuit current (ICC = 3xIn) makes it suitable for loads that require high current peaks during switch-on or during normal operation.

### DC voltage 220 V

The input and inverter transformers guarantee the isolation of the batteries, which are sized for a voltage of 220 Vdc (from 108 to 114 elements), the standard industrial value.

## Redundant ventilation

Redundant ventilation at 100% load is standard, ensuring operation with a normal load with half of the fans operating; in addition, each fan is monitored and an alarm signal is provided in the event of failure. The Easy Source input features, the Battery Care System, and the flexibility and communications capabilities are the same as those of the conventional Master MPS range (page 86).

## OPTIONS

### SOFTWARE & ACCESSORIES

See Master MPS (page 88)

### PRODUCT ACCESSORIES

Isolation transformer  
Synchronisation device (UGS)  
Hot connection device (PSI)  
Digital I/O and Generator interface  
Parallel configuration kit (Closed Loop)  
Battery cabinets empty or for extended runtimes  
Top Cable Entry cabinets  
IP rating IP31/IP42

## DIMENSIONS

MIM 30 - MIM 40

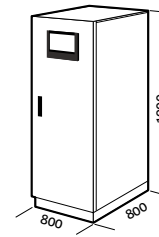

MIM 60 - MIM 80

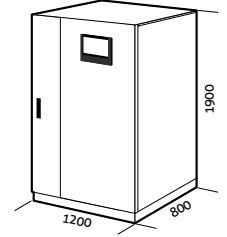

MODELS	MIM 30	MIM 40	MIM 60	MIM 80
<b>INPUT</b>				
Nominal voltage	380 - 400 - 415 Vac three-phase			
Voltage tolerance	400 V $\pm$ 20%			
Frequency	45 - 65 Hz			
Power factor	> 0.93			
Current distortion	< 6%			
Soft start	0 - 100% in 120" configurable			
Permitted frequency tolerance	$\pm$ 2% (selectable from $\pm$ 1% to $\pm$ 5% from front panel)			
Standard equipment provided	Back Feed protection; separable bypass line; battery isolation			
<b>BATTERIES</b>				
Type	VRLA AGM / GEL; NiCd			
Number of cells	108/114			
Maximum charging voltage	274 V			
Temperature compensation	-0.5 V $\times$ °C			
<b>OUTPUT</b>				
Nominal power (kVA)	30	40	60	80
Active power (kW)	24	32	48	64
Nominal voltage	230 Vac single-phase			
Static stability	$\pm$ 1%			
Dynamic stability	$\pm$ 5%			
Voltage distortion	< 1% with linear load / < 3% with non-linear load			
Frequency	50 or 60 Hz (selectable)			
Crest factor	3:1 I <sub>peak</sub> /I <sub>rms</sub>			
Overload	110% for 60 minutes; 125% for 10 minutes; 150% for 1 minute			
Short-circuit current	3 x I <sub>nom</sub> .			
<b>INFO FOR INSTALLATION</b>				
Weight (kg)	640	650	910	940
Dimensions (WxDxH) (mm)	800 x 800 x 1900		1200 x 800 x 1900	
Remote signals	dry contacts			
Remote controls	ESD and bypass			
Communications	Double RS232 + dry contacts + 2 slots for communications interface			
Operating temperature	0 °C / +40 °C			
Relative humidity	<95% non-condensing			
Colour	Light grey RAL 7035			
Noise level at 1 m (ECO Mode)	68 - 70 dBA			
Ventilation	Redundant fans (front-top)			
IP rating	IP20			
Efficiency	up to 94%			
Standards	Directives LV 2006/95/EC - 2004/108/EC; Safety IEC EN 62040-1; EMC IEC EN 62040-2; Performance IEC EN 62040-3			
Classification in accordance with IEC 62040-3	(Voltage Frequency Independent) VFI - SS - 111			
Moving the UPS	Pallet Jack			



TRANSPORT

# Master FC400



ONLINE



Tower



**3:3** 30-125 kVA



Service  
1st start



Airport/  
Shipyards

## HIGHLIGHTS

- **Frequency converter 50/400 Hz**
- **Output voltage: 208 V - 3F**
- **Galvanic isolation**
- **Applications: airport, military and naval**
- **Battery backup**

Master FC400 series static frequency converters are available from 30 to 125 kVA, with 50 or 60 Hz input and 400 Hz output. The result of extensive experience acquired in the UPS industry, the Master FC 400 series is distinguished by the use of technologically advanced components and for excellent reliability, ease of maintenance and ease of operation.

The Master FC400 series uses double conversion technology (VFI SS 111 voltage and frequency independent compliant with IEC EN 62040-3), with an integrated output transformer to ensure the galvanic isolation of the load from mains disturbances under all conditions.

The output voltage is 208 Vac three-phase

(adjustable 200-215 Vac). Thanks to high frequency IGBT technology and digital control, Master FC400 frequency converters are ideal for airport, military and naval applications.

### Minimum impact on mains - easy source

The Master FC400 was designed to reduce to a minimum the impact on the mains or generator located upstream, thanks to the low harmonic content input and the progressive start of the rectifier. These features make the Master FC400 frequency converters especially compatible with generators.

## Easy installation and maintenance

The Master FC400 requires a small space for installation (only 0.86 m<sup>2</sup> for a 125 kVA model). The main assemblies of the UPS can be easily accessed for maintenance, via the removable front panel. Fans located in the top of the UPS cabinet, eliminate the need for side or rear access, and allow the UPS to be placed against a wall.

## Applications

Master FC400 provides additional protection for a wide range of applications, including:

- Powering airplanes in airports
- Radar and flight-control systems
- Naval applications
- Military applications
- Power for test benches.

## Battery Back-up

MFC is also available as UPS with battery back-up.

## DIMENSIONS

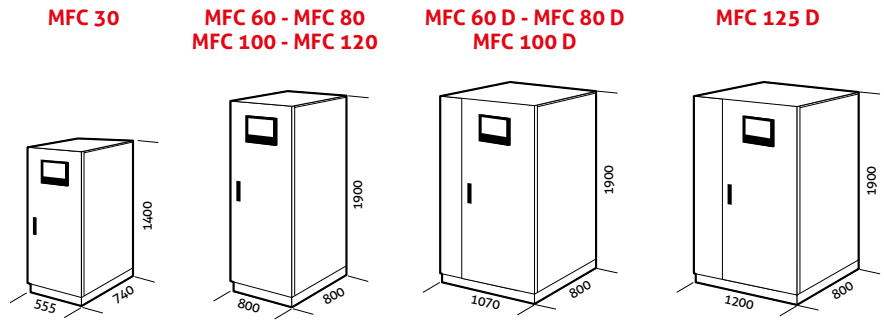

## OPTIONS

### SOFTWARE & ACCESSORIES

See Master MPS (page 88)

### PRODUCT ACCESSORIES

Input isolation transformer

IP rating IP31/IP42

Parallel configuration kit (Closed Loop) 12 pulse version (D)

Filtering of 5<sup>th</sup> and 11<sup>th</sup> harmonics (HC)

Top Cable Entry cabinets

Digital I/O and Generator interface

MODELS	MFC 30	MFC 60	MFC 80	MFC 100	MFC 125
<b>INPUT</b>					
Nominal voltage	380 - 400 - 415 Vac three-phase				
Voltage tolerance	400 V ± 20%				
Frequency	45 - 65 Hz				
Current distortion	< 5% C (HC Version)				
Soft start	0 - 100% in 120" configurable				
<b>OUTPUT</b>					
Nominal power (kVA)	30	60	80	100	125
Active power (kW)	24	48	64	80	100
Nominal voltage	208 Vac three-phase + N				
Static stability	± 1%				
Dynamic stability	± 5%				
Voltage distortion	< 3% with linear load / < 4% with non-linear load				
Frequency	400 Hz				
Crest factor	3:1 lpeak/lrms				
Overload	110% for 60 minutes; 125% for 10 minutes; 150% for 1 minute				
<b>INFO FOR INSTALLATION</b>					
Weight (kg)	330	480	500	530	590
Dimensions (WxDxH) (mm)	555 x 740 x 1400	800 x 800 x 1900			
Remote signals	dry contacts				
Remote controls	ESD and ON/OFF				
Communications	Double RS232 + dry contacts + 2 slots for communications interface				
Operating temperature	0°C / +40°C (50°C @ 75% load)				
Relative humidity	<95% non-condensing				
Colour	Light grey RAL 7035				
Noise level at 1 m (ECO Mode)	62 dBA	65 dBA	68 dBA	70 dBA	72 dBA
IP rating	IP20 (others on request)				
Efficiency	up to 92%				
Standards	Directives LV 2006/95/EC - 2004/108/EC; Safety IEC EN 62040-1; EMC IEC EN 62040-2; Performance IEC EN 62040-3				
Classification in accordance with IEC 62040-3	(Voltage Frequency Independent) VFI - SS - 111				
Moving the UPS	Pallet Jack				







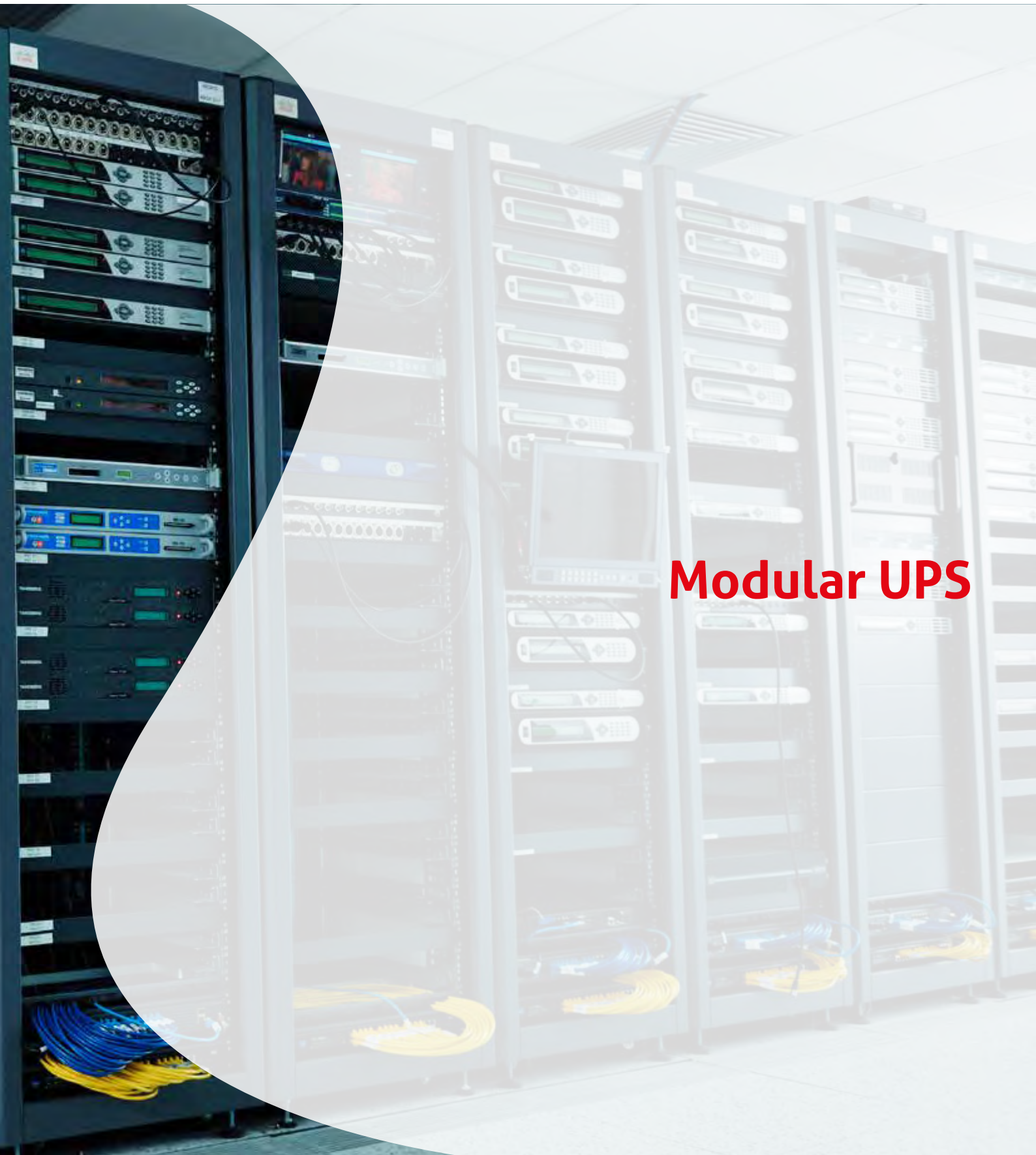

## Modular UPS



DATA CENTRE TRANSPORT

# Multi Power



ONLINE



Modular



**3:3** 25-600 kW  
+ redundancy  
42-1008 kW  
+ redundancy



USB  
plug



SmartGrid  
ready



## HIGHLIGHTS

- Utmost Availability
- Ultimate Scalability
- Unmatched Power Density
- Efficiency > 96.5%
- Multiple Controls
- Highly Flexible
- Multiple comms

The Riello MULTI POWER (MPW) is the ultimate modular UPS for DATA CENTRES and other CRITICAL LOADS. The MULTI POWER is designed to protect any critical high-density computer and IT environment, whilst achieving maximum availability. The MPW grows along with the demands of the business without over-sizing the UPS - optimizing both the initial investment and the Total Cost of Ownership. As soon as demand increases, the Riello MPW modular solution can expand its power capability, maintaining the highest levels of power protection, availability, redundancy and investment savings. Digital technology has an increasingly strong influence on day-to-day activities in almost all sectors and applications such

as healthcare, power generation, social networking, telecommunications, commerce and education. Subsequently, any activities and equipment related to data storage, processing and transfer should be supplied from the most reliable power source. Multi Power ensures that a scalable, secure, high quality power supply is available for a variety of critical load applications. The new MPW **Power Modules** feature the very latest in UPS technology. With its three level Neutral Point Clamped (NPC) inverter and Power Factor Corrected (PFC) input control, the MPW ensures the highest level of performance in terms of overall efficiency, input power factor and harmonic impact on the supply source.



## Advanced Technology

To ensure the highest levels of power availability, only the most reliable, cutting edge power components and innovative control technologies have been used in the development of the MPW power modules and other major aspects of the system. The major power components and assemblies within the MPW have been specifically designed and tailor made in conjunction with the respective component manufacturers. This design work ensures that the MPW achieves the highest levels of power and performance.

In order to optimize the overall performance of the finished product, Riello's R&D team made the decision to specifically design certain power components, including the IGBT modules and associated packages. Rather than using standard components that are readily available in the marketplace, the Multi Power hosts one single optimised and reliable power assembly which guarantees the best availability and overall efficiency.

The Power Module itself utilizes a "wireless power principle" meaning that the power interconnection distances between the cards, power components and connectors are shorter. In this way we reduce any risk related to connection problems between the assemblies and also minimize the overall power losses.

## Scalability

Multi Power provides a comprehensive, easy to integrate power protection solution for data centres and any critical IT application matching the evolving demands of a networked environment. The end user can easily increase power, redundancy level and battery autonomy by simply adding additional UPS **Power Modules (PM)** and **Battery Units (BU)**. Three different cabinets are available to build the system:

The **Power Cabinets** (PWC - 2 versions) and the **Battery Cabinet**. The Power Cabinets can accommodate either only the 25 kW Power Modules (PM25) or 42 kW Power Modules (PM42).

The available UPS power and redundancy level can expand vertically using the PM25 power module from:

- 25 to 125 kW in one single Power Cabinet (PWC 130)
- 25 to 175 kW in one single Power Cabinet (PWC 300)

Also, power solution can expand vertically using the PM42 power module from:

- 42 to 294 kW in one single Power (PWC 300)
- Up to four complete Power Cabinets can be connected in parallel, increasing the capacity including redundancy respectively from:

- 125 up to 500 kW (with PM25)
- 175 up to 700 kW (with PM25)
- 294 up to 1176 kW (with PM42)

The Battery Cabinet accommodates multiples of 4 Battery Units, with up to 36 units within a single frame with a maximum of 10 Battery Cabinets connected in parallel.

In addition, the MPW is available as an optimized solution providing a Multi Power/ Battery combination with three UPS Power Module slots and five battery shelves (**Combo Cabinet**). This solution can be utilized within extremely compact areas requiring a small footprint with maximum power density. This modular and reliable solution is perfect for any small to medium business applications. The user might decide to build the solution using the combination of three PM either PM25 or PM42 kW power not mingling the two power rates in the same cabinet.

## Outstanding Performances

- The advanced technologies deployed within the MPW guarantees full rated power even with unity power factor loads (kVA=kW) without any power downgrading even when operating at temperatures up to 40°C.
- High system efficiency whilst operating in on-line double-conversion mode greater than 96.5%. Even when loaded at only 20%, the MPW still achieves an outstanding performance greater than 95%. This superior performance ensures extremely low losses at any load level whilst maintaining a true modular solution for any changing UPS environment in terms power demands.



Power Module 25 kW - PM25



Power Module 42 kW - PM42



Battery Unit Array - 4 x BU

- Low input harmonic pollution, with near unity input power factor and an extremely wide input voltage operating range (+20/-40%), requiring only a minimum upstream power source rating and subsequent reduced investment costs.

## Multiple Controls

The entire Multi Power solution was developed with particular care to ensure



Power Cabinet 300 (1-7 x PM25 or PM42) x 4





operational reliability and prevent any possible failures due to miscommunication between the component parts of the system. The Power Modules are not controlled by one unique microprocessor, but by three - each having different and specific duties. Likewise, the Power Cabinet features two separate microprocessors; one to regulate the overall UPS operations and a separate one to manage communication with the user.



*Combo Cabinet 130 1-3 x PM25 or PM42 + 1-5 Battery Shelves with air filter on front door (optional available on all cabinet types).*

In addition, three dedicated communications bus manage and transmit the data. In terms of the monitoring and control of the overall system, all major components are continually temperature monitored within each of the Power Modules. In addition, up to four-temperature sensors are embedded within the Power Cabinet to ensure constant and efficient operation. The Power Module is equipped with three speed controlled fans to ensure there is no energy wasted as the load level applied to the system increases or decreases. At the same time each fan features a so-called third wire (the controller) which immediately warns the microprocessor in the event of a fault; in which case the microprocessor will increase the speed of the remaining operational fans in order to compensate for the cooling deficiency. The Battery Unit also contains dedicated internal protection and a sophisticated control system to monitor the status of each module. This makes it possible to check the voltage/current supplied by each single battery module and therefore identify and warn the user if one of them is defective or beginning to fail. This significantly reduces the risk of a battery pack failure causing a problem to the system by immediately warning the user of the impending issue in order for the appropriate preventive actions to be taken before it is too late.

### **Flexible Modularity**

Multi Power grows both vertically and horizontally from 1 to 28 Power Modules increasing from 25/42 to 700/1176 kW (including redundancy) as well as battery units (from 1 cabinet, up to 10), therefore the system is completely scalable in accordance with any business requirements.



*Battery Cabinet with open and closed door.*

The Plug & Play modular concept simplifies any power or battery autonomy expansion process, rather than a complete Power Module or Battery unit replacement. The modular hot-swappable principle is further extended to all major elements of the system, resulting in convenient replacement of parts such as fans from within individual Power Modules rather than accessing major components within the cabinet. Furthermore, all Power Modules and critical components are easily accessible from the front of the unit as standard. The system is equipped with a **Manual Bypass** change over switch and **Backfeed** control with a mechanical



interlock contactor inbuilt, eliminating any maintenance-related downtime. Combination systems (Combo Cabinet with Battery Cabinet) are supplied with a battery switch and shunt trip to enable remote battery switch operation. All these features ensure easy UPS expansion, operation and maintenance; minimizing downtime, decreasing the Mean Time to Repair (MTTR) and removing any possible risk to power continuity, when carried out by authorized service personnel. Flexibility is measured by the ease of both on site installation and the operations undertaken by the user. Input/Output/battery terminal bars are deployed enabling authorized installers to easily terminate the cables either from the top or the bottom of the system. Mechanical supports and cable glands as well as the terminal bar positioning (in the centre of the cabinet) are purposely positioned to reduce the installation time and costs. In addition, in terms of flexibility of the battery installation, whether a conventional or modular type system is implemented these can be arranged in two different configurations: centralised (common battery) or distributed (separate battery for each Power/Combo Cabinet). This will ensure the highest level of adaptability for any critical installation and/or economical driving factors.

### Turn Key Solutions

User may deploy Multi Power cabinets lining up four Cabinets one to each other and arranging locally for input and output cabling. Riello UPS offers as alternative a 500 kVA turn-key solution which consist in two Power Cabinets and a Switching Cabinet to tie up the two. It includes AC input/output terminals for site power distribution connection, related joining flexible bars and communication links between Power Cabinets and Switching Cabinet. Switching Cabinet is also supplied with AC input/output/bypass lines breakers as well as with an integral wrap around maintenance bypass. Bypass line is protected with fuses to grant fault discrimination and load protection in case of short circuit downstream.



MPW LCD Touch screen: user friendly UPS configuration and monitoring display.

The breaker set enable to galvanically insulate the single Power Cabinets and to carry out specific maintenance. Switching Cabinet cable entry is arranged so that user may decide either to access from the bottom front, rear side or top. This on hand solution simplify the installation activity and contribute to the overall TCO reduction minimizing, upfront, installation and operating costs.

### Advanced Communications

Users can benefit from the different communication systems developed specifically for IT personnel, facilities managers and service engineers. The 7" LCD touch screen, communication slots, relay cards along with the dedicated service ports, all ensure that the UPS setup, control and monitoring is easy. The MPW LCD touch screen has embedded the follow protocols:

- UDP to communicate with our shutdown software PowerShield<sup>5</sup>
- HTTP and HTTPS to monitor the UPS status using a standard web browser without any additional software.
- SMTP to send emails related to the UPS status, alarms and a power quality daily and weekly report.

In addition, with the network card NetMan 204, MPW can be integrate into any building management system and data centre infrastructure (CDIM) with the protocols:

- SNMP v1, v2 and v3.
- Modbus/TCP.

Multi Power is compatible with the very latest operating systems including

- Windows 7, 8, 10
- Hyper-V
- Windows Server 2016, 2012, and previous versions
- Mac OS X
- Linux
- VMWare ESXi
- Citrix XenServer

and many other Unix operating systems.

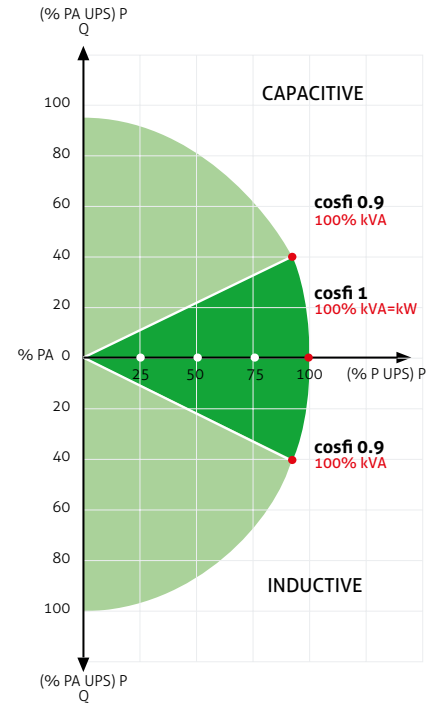

Power Cabinet 130 (1-5 x PM25).

### OPTIONS

#### SOFTWARE

- PowerShield<sup>5</sup>
- PowerNetGuard

#### ACCESSORIES

- NETMAN 204
- MULTICOM 302
- MULTICOM 352
- MULTICOM 372
- MULTICOM 384
- MULTI I/O

#### MULTIPANEL

#### PRODUCT ACCESSORIES

- Battery temperature sensor
- Air Filter on front door
- IP21 Protection Kit
- Programmable relay board
- MULTICOM 392

# DETAILS

## PWC 130

**MPW Power Cabinet 130**  
25-125 kW  
(front)

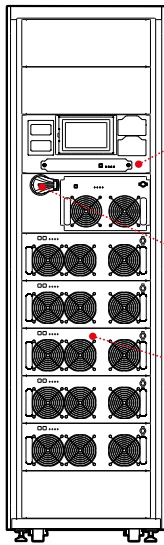

- CONNECTIVITY PANEL (CP)
- MANUAL BY-PASS SWITCH (SWMB)
- POWER MODULE (PM25)

## PWC 130

**MPW Power Cabinet 130**  
25-125 kW  
(rear)

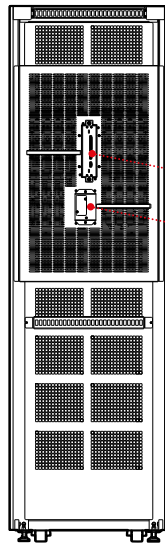

- AUXILIARY SIGNAL BOARD (ASB)
- RELAY SLOT

## BTC 170

**MPW Battery Cabinet (front)**

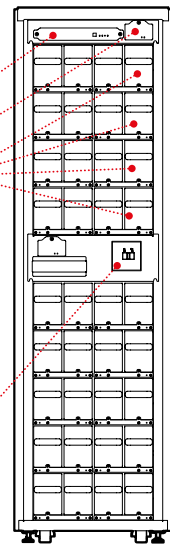

- MONITORING UNIT (MU)
- POWER SUPPLY UNIT (PSU)
- BATTERY UNIT (BU)
- BATTERY SWITCH (SWBATT)

## PWC 300

**MPW Power Cabinet 300**  
25-175 kW  
or 42-294 kW  
(front)

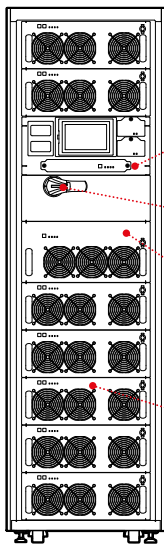

- CONNECTIVITY PANEL (CP)
- MANUAL BY-PASS SWITCH (SWMB)
- BYPASS MODULE (BM)
- POWER MODULE (PM)

## PWC 300

**MPW Power Cabinet 300**  
25-175 kW  
or 42-294 kW  
(rear)

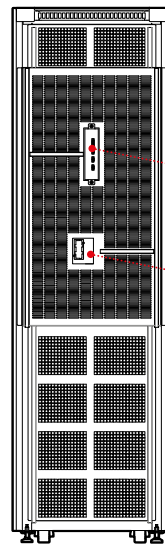

- AUXILIARY SIGNAL BOARD (ASB)
- RELAY SLOT

## BTC 170

**MPW Battery Cabinet (front)**

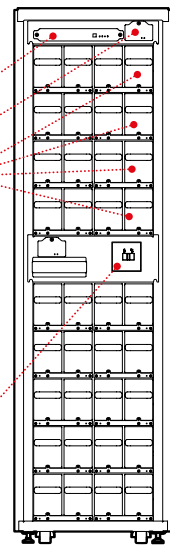

- MONITORING UNIT (MU)
- POWER SUPPLY UNIT (PSU)
- BATTERY UNIT (BU)
- BATTERY SWITCH (SWBATT)

## CBC 130

**MPW Combo Cabinet 130**  
25-75 kW  
or 42-126 kW  
(front)

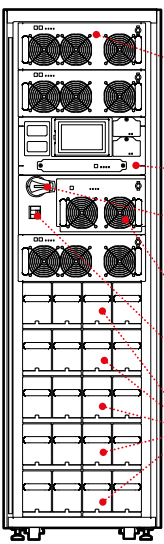

- POWER MODULE (PM)
- CONNECTIVITY PANEL (CP)
- MANUAL BY-PASS SWITCH (SWMB)
- BYPASS MODULE (BM)
- BATTERY SWITCH (SWBATT)
- BATTERY UNIT (BU)

## CBC 130

**MPW Combo Cabinet 130**  
25-75 kW  
or 42-126 kW  
(rear)

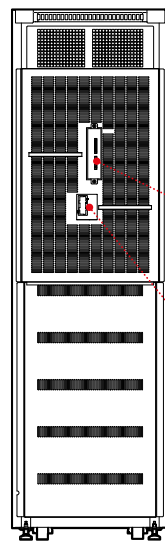

- AUXILIARY SIGNAL BOARD (ASB)
- RELAY SLOT

## BTC 170

**MPW Battery Cabinet (front)**

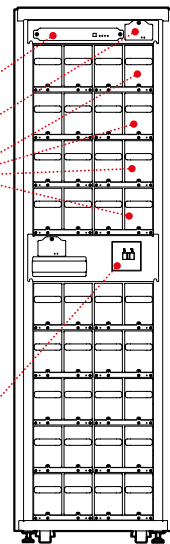

- MONITORING UNIT (MU)
- POWER SUPPLY UNIT (PSU)
- BATTERY UNIT (BU)
- BATTERY SWITCH (SWBATT)

## DETAILS

**MPW Switching Cabinet 500  
+ 2 x Power Cabinet 300  
(front without doors)**

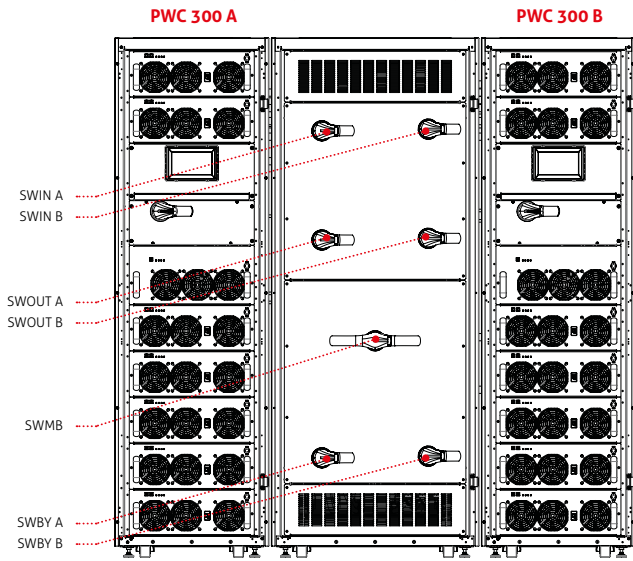

**MPW Switching Cabinet 500  
+ 2 x Power Cabinet 300  
(rear without panels)**

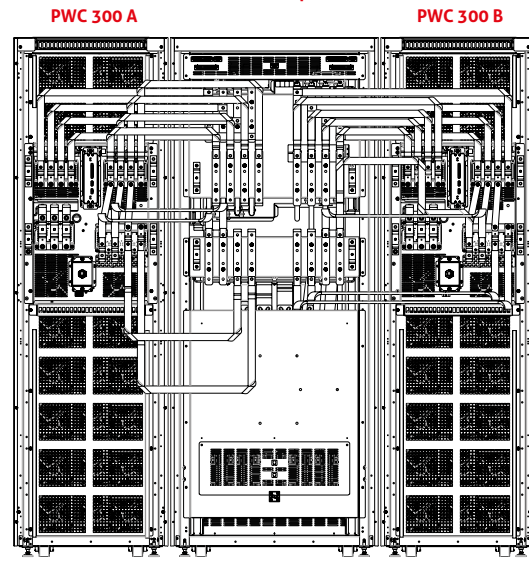

**AUXILIARY SIGNAL BOARD (ASB)**

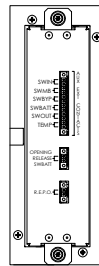

**CONNECTIVITY PANEL (CP)**

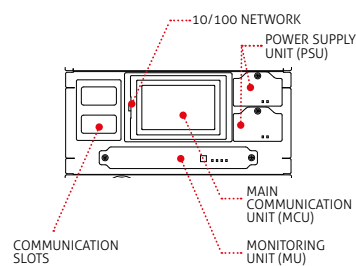

## CABINETS

<b>MODELS</b>	<b>CABINET MPW BATTERY CABINET MPW BATTERY (Modular Battery Cabinet)</b>	<b>BB 2000 480-V6 / BB 2000 480-V7 BB 2000 480-V8 / BB 2000 480-V9 / AB 2000 480-V9 (Conventional Battery Box)</b>
<b>UPS MODELS</b>	Select the Battery configuration according Multi Power range	

Dimensions  
(mm)

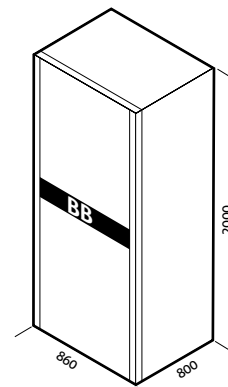
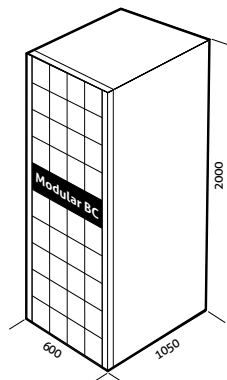

MODEL	MPW - from 25 to 294 kW <sup>1</sup>				
<b>INPUT</b>					
Voltage [Vac]	380-400-415 Three-Phase plus neutral				
Voltage tolerance [V]	240 to 480 <sup>2</sup>				
Frequency tolerance [Hz]	40 to 72				
Power factor	1				
THDI [%]	< 1.5				
<b>BYPASS</b>					
Nominal power [kW]	252 / 126 (According to system power configuration)				
Nominal voltage [Vac]	380-400-415 Three-Phase plus neutral				
Voltage tolerance [V]	from 180 (adjustable 180-200) to 264 (adjustable 250-264) referring to Neutral				
Nominal frequency [Hz]	50 or 60				
Overload	125% for 10 minutes; 150% for 1 minute				
<b>BATTERIES</b>					
	<b>Modular Type (BTC 170)</b>		<b>Conventional Type</b>		
Layout	Modular type made up by Battery Unit (named BU)		Free Standing Battery Box / Shelf		
Battery features	VRLA batteries lined up inside BU; Constant voltage and current measuring at BU level; Battery status monitoring via MPW LCD display		Conventional battery Blocks VRLA Type		
Cabinet lay out description	9 x Battery shelves		1 x (20 + 20) Blocks		
Dimensions [WxDxH]	600x1050x2000		860x800x2000		
Weight [kg] (without PM <sup>3</sup> /BU <sup>4</sup> )	280		250		
<b>OUTPUT</b>					
Nominal voltage [Vac]	380/400/415 Three-Phase plus neutral				
Nominal frequency [Hz]	50 or 60				
Voltage stability [%]	± 0.5				
Dynamic stability	EN62040-3 class performance 1 distorting load				
<b>OVERALL SPECIFICATION</b>					
Cabinet type	<b>PWC 130 Power Cabinet 130</b>	<b>PWC 300 Power Cabinet 300</b>	<b>PWC 300 Power Cabinet 300</b>	<b>CBC 130 Combo Cabinet 130</b>	<b>CBC 130 Combo Cabinet 130</b>
Power Module nominal power [kW] (Named PM)	PM25	PM25	PM42	PM25	PM42
Solution nominal Power [kW]	125	175	294	75	126
Output power factor [pf]	1	1	1	1	1
Parallelable (up to)	4	4	4	4	4
Cabinet layout description	5 x PM25	7 x PM25	7 x PM42	3 x PM25 5 x Battery shelves	3 x PM42 5 x Battery shelves
Dimensions [WxDxH]	600x1050x2000	600x1050x2000	600x1050x2000	600x1050x2000	600x1050x2000
Weight [kg] (without PM <sup>3</sup> /BU <sup>4</sup> )	240	300	300	340	340
System Noise Level at 1 m [dBA±2]	<65	<68	<68	<64	<64
Eco Mode Efficiency	Up to 99%				
Cabinet IP rating	IP20 finger proof (either with cabinet doors open or close)				
Cable input	Rear side either top or bottom				
Colour	RAL 9005				
Standards	Safety: IEC EN62040-1 EMC: IEC EN 62040-2-category C2				
Moving UPS cabinet types	Castors (any cabinet type is shipped without PM and BU)				

<sup>1</sup> Including Redundancy

<sup>2</sup> Conditions applied

<sup>3</sup> PM = Power Module (either referring to PM25 or PM42 kW)

<sup>4</sup> BU = Battery Unit

NOTE: All performances quoted in a single row refer to any UPS system configuration from one to seven modules running in parallel unless specified differently.



## MPW EMBEDDED PROTOCOLS

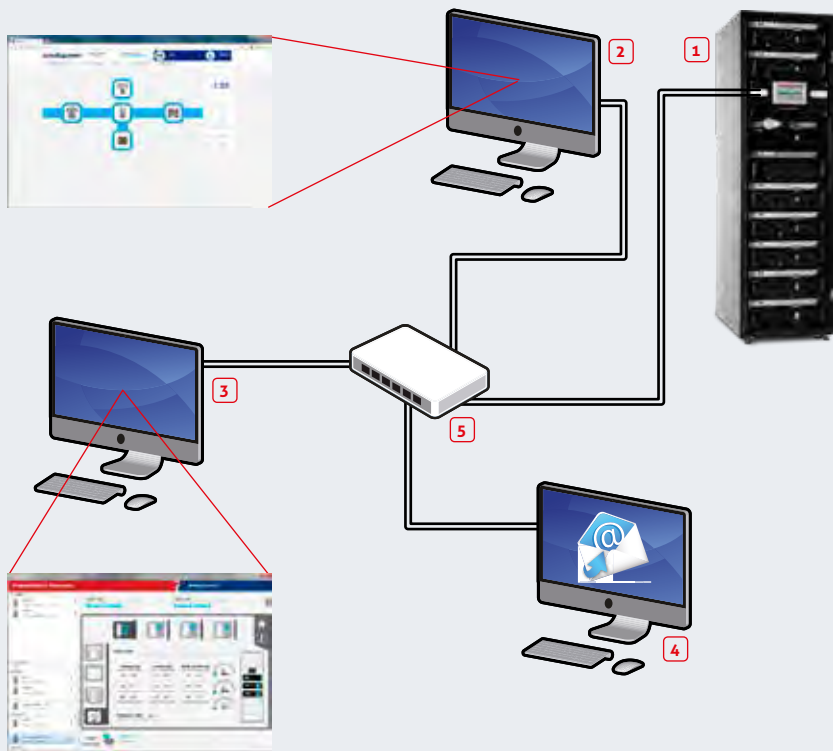

- 1 MPW
- 2 Web Browser
- 3 PowerShield<sup>3</sup>
- 4 Mail Server
- 5 Ethernet Switch
- Ethernet

## MPW PROTOCOLS ADDING NETMAN 204 CARD

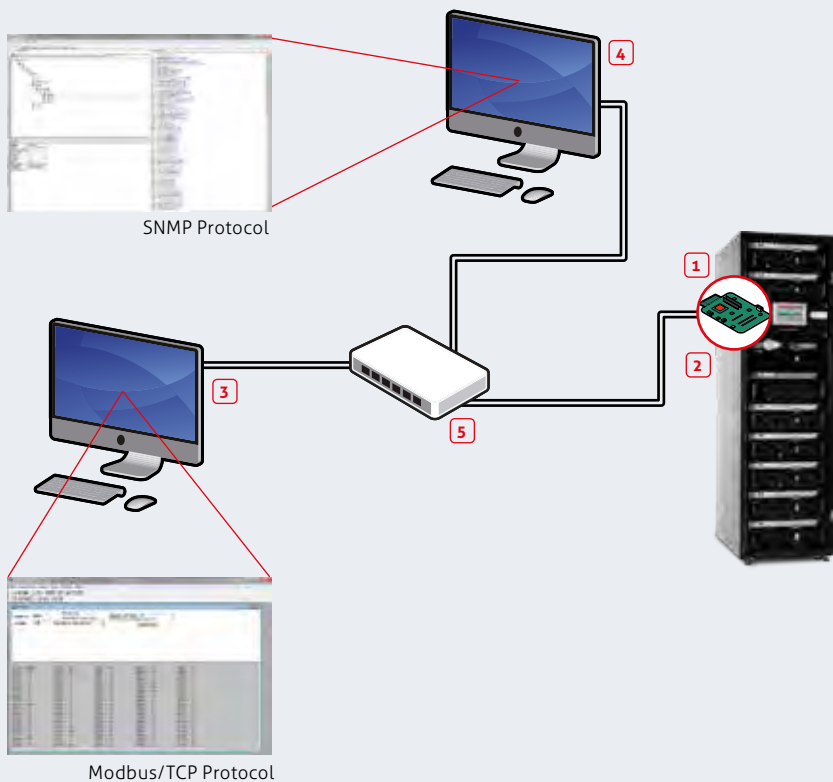

- 1 MPW
- 2 Netman 204 board
- 3 Modbus/TCP Manager
- 4 SNMP Manager
- 5 Ethernet Switch
- Ethernet

# Multi Guard Industrial



DATACENTRE



E-MEDICAL



INDUSTRY



TRANSPORT



ONLINE



Modular



**1-3:1** 20 x 160 kVA

**1-3:3** 20 x 160 kVA



USB plug



SmartGrid ready



Service 1st start

## HIGHLIGHTS

- High adaptability to input voltage
- Zero impact source
- Compatible with industrial environments
- Modular Plug & Play solution
- Complete flexibility

The Multi Guard Industrial range was specially developed to ensure power continuity in all sectors deemed critical due to the specific environmental conditions or industrial processes requiring protection. Multi Guard Industrial is available in a 20 kVA stand alone version and in modular versions from 20 to 160 kVA. The two versions are available in both single-phase and three-phase output configurations. This high level of flexibility allows Multi Guard Industrial to accept both single-phase and three-phase inputs with no need for special set ups or operator intervention, ensuring full compatibility with any power supply network.

### High adaptability to input voltage

Multi Guard Industrial is available in two versions: single-phase and three-phase output, whilst the input stage accepts both a triplet of three-phase supplies out-of-phase by 120° (three-phase 400 V+N) or a triplet of power supplies in phase (single-phase 230 V+N). Thanks to its power supply recognition function the UPS is able to adapt to the input power supply with no need for additional configuration, ensuring the same performance under both applied voltage conditions.

### Zero impact source

Thanks to the technology it employs,



Parallel configuration and programmable relay contacts board



Harting connectors

Multi Guard Industrial solves all problems connected with insertion into power supply grids with limited power, where the UPS is supplied by a generator and where the same network includes single-phase (e.g. railway voltage) and three-phase (e.g. emergency power supply from a generator) supplies. Multi Guard Industrial has zero impact on the power supply source, whether it is a mains grid or generator set, single-phase or three-phase:

- power supply voltage recognition (single/ three-phase), with no need for setting up or reconfiguring parameters
- input current distortion <3%
- input power factor 0.99
- power walk-in function that ensures progressive rectifier start up
- start-up delay function, to restart the rectifiers when mains power is restored if there are several UPS in the system.
- 'cold start' function for starting the UPS from the battery.

In addition, Multi Guard Industrial plays a filtering and power factor correction role in the power network upstream of the UPS as it eliminates harmonic components and reactive power generated by utility suppliers.

### Compatible with industrial environments

The mechanical structure of Multi Guard Industrial makes it particularly versatile for use in many different sectors.

The basic building blocks are 20 kVA UPS. The cabinet is able to house up to four 20 kVA modules and up to two cabinets can be connected in parallel for a total of eight UPS modules and 160 kVA of power. The module connection clamps are laid

out so that the communication signal connections are segregated and separated from the power connections (input, output, bypass line, battery), thus ensuring complete immunity from interference generated by the power supply grid, which is typically disturbed in industrial environments. Both versions (single-phase and three-phase output) are provided with a bypass line separated from the power supply line. This ensures greater availability in that the customer may have a preferential line for the bypass that is not restricted by the potential interference or interruptions that the UPS power supply line may be subject to. The UPS module has a front to back air flow, allowing the UPS to be installed in any environment and preventing the types of ingress problems associated with top-vented circulations cabinets. Every UPS module in the Multi Guard Industrial range can be equipped with a parallel board, a relay board with eight programmable outputs and three inputs (one of which is programmable), and two slots for housing communications interface boards from the MultiCOM range, making the UPS compatible with the various types of protocols and supervision systems typical of the industrial environment.

The cabinet is designed to house up to four UPS modules. It has an area that contains all the protection devices and disconnectors for the individual modules (4 input disconnectors, 4 battery disconnectors, 4 bypass line disconnectors and 4 output disconnectors), as well as a manual bypass for isolating the four modules and guaranteeing power continuity in the event of the complete failure of all the UPS units or in the event of scheduled system overhaul.

The cabinet is also equipped with an area that can be used for the insertion of a whole range of accessories for monitoring power that the user can request (surge arresters, energy meters, earth discharge detectors, output distribution, release coils, etc), making the solution compact and optimised for any field of use.

### Modular Plug & Play solution

Multi Guard Industrial can be purchased as a single 20 kVA UPS module and installed in any cabinet or mechanical support provided by the user. The power terminals (input, output, battery) are connected by Harting connectors, ensuring simplicity and operating safety during insertion/removal, protection against electrical contacts and immunity from environmental conditions typical of industrial environments (dust, humidity, suspended chemical particles). The removal and replacement of a faulty module or the addition into the system of a further UPS module to increase available power or redundancy can be carried out easily by the operator responsible for the system.

### Complete flexibility

Multi Guard Industrial is the ideal solution for industrial environments in which the UPS must adapt to the various requirements typical of this application. Aside from the distinction between single-phase and three-phase output voltages, the UPS module can be used as a stand-alone unit or in a parallel configuration; by simply adding the parallel configuration board in the slot on the front of the module, the UPS can grow as requirements demand (from 20 to 160 kVA). Multi Guard Industrial ensures horizontal

scalability that minimises the system footprint, the user can thus have power capabilities from 20 to 80 kVA without increasing the footprint. This is particularly advantageous when the system is installed in environments with space limitations (e.g. containers, historic buildings, sites spread out over a territory).

Each UPS is equipped with a graphic display, a programmable relay board slot and two slots for communications interfaces, all situated at the front for quick and organised installation.

Every UPS module in the Multi Guard Industrial range is completely independent with regards to the control and management of the operator interfaces; this facilitates all monitoring, control and fault-detection operations, ensuring increased reliability in that any malfunctions in parts or accessory will not propagate through the entire system. Multi Guard Industrial is a UPS that uses many components also used in the Multi Sentry range; in particular the display and navigation menus are the

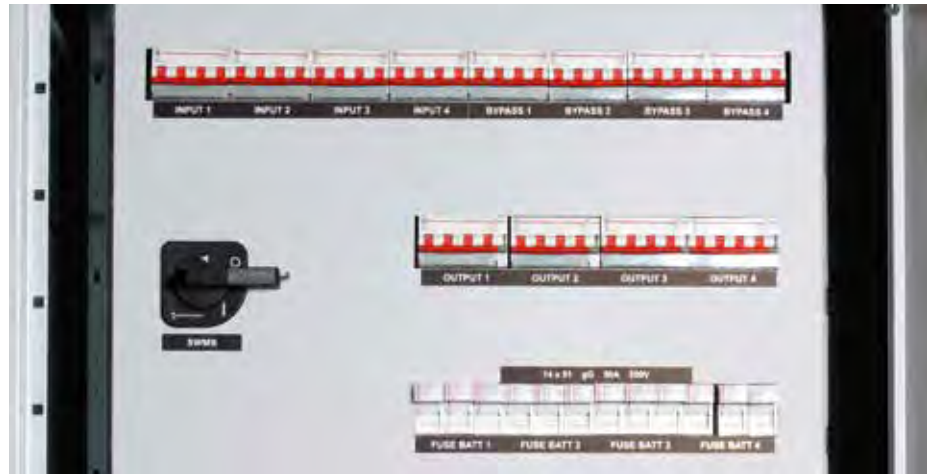

Detail of protective devices and disconnectors

same: this allows for rapid and intuitive access to information as well as simplified management of the spare parts in storage.

**Stand-alone version:**

Different from the cabinet version, the stand alone system is supplied with input, bypass line, output and battery connectors with loose cables three metres in length and filter

boards that the installation technician must position inside the destination cabinet or near the module.

**OPTIONS**

**SOFTWARE**

- PowerShield<sup>3</sup>
- PowerNetGuard

**ACCESSORIES**

- NETMAN 204
- MULTICOM 302
- MULTICOM 352
- MULTICOM 384
- MULTI I/O
- MULTIPANEL

**PRODUCT ACCESSORIES**

- Battery temperature sensor
- Powerful battery charger
- Programmable relay board MULTICOM 392
- IP rating IP31/IP42
- Internal batteries
- MST range battery cabinets



**DETAILS**

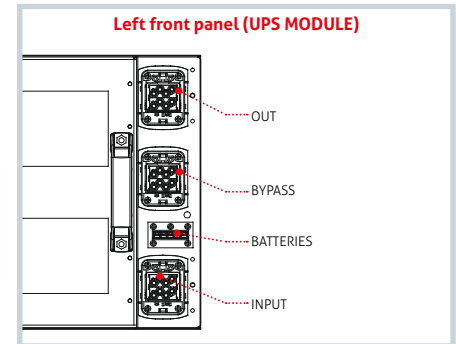
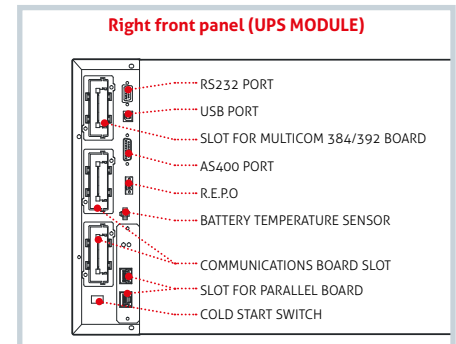



MODEL	GMI single-phase output (GMI M) from 20 kVA to 160 kVA	GMI three-phase output (GMI T) from 20 kVA to 160 kVA
<b>INPUT</b>		
Voltage	380-400-415 Vac, three-phase + N and 220-230-240 Vac single-phase + N (input voltage recognition function)	
Voltage tolerance	-40/+20% *	
Frequency tolerance	between 40 Hz and 72 Hz	
Power factor	>0.99	
THDI	< 3%	
<b>BYPASS</b>		
Voltage	220-230-240 Vac, single-phase + N	380-400-415 Vac, three-phase + N
Voltage tolerance	180 - 264 V (selectable) referring to neutral phase	
Overload	125% for 60 minutes; 150% for 18 minutes	
<b>OUTPUT</b>		
Voltage	220-230-240 Vac, single-phase + N (selectable)	380-400-415 Vac, three-phase + N (selectable)
Voltage stability	≤ 1%	
Frequency	50 Hz / 60 Hz	
<b>UPS MODULE</b>		
Power	20 kVA / 18 kW	
Output power	20 kVA x number of modules, up to a maximum of 8 (max. 160 kVA)	
<b>BATTERIES</b>		
Layout	independent batteries for each UPS module or shared by the UPS system	
Type	VRLA AGM/GEL	
Recharge time	6 hours	
<b>SPECIFICATIONS</b>		
Noise level at 1 m (ECO Mode)	from ≤ 52 dBA to ≤ 70 dBA	
Operating temperature	0 °C / +40 °C	
Humidity	20% - 90% non-condensing	
Storage temperature	-15° +55°	
UPS module weight (kg)	64	
UPS module dimensions (WxDxH) (mm)	620 x 745 x 320	
GMI cabinet weight (kg)	200 (UPS modules excluded)	
GMI cabinet dimensions (WxDxH) (mm)	850 x 850 x 2060	
Modular battery cabinet dimensions (WxDxH) (mm)	9 battery shelves, 36 battery modules 597 x 1003 x 2000	
Eco Mode efficiency	up to 99%	
Standards	Safety: IEC 62040-1 EMC: IEC 62040-2	
Moving the UPS	Pallet Jack (UPS cabinet) - 2 operators (UPS module)	

\* conditions applied

NOTE: The GMI UPS is also compatible with the battery cabinets in the Multi Sentry range (MST)





# **CPSS Central Power Supply Systems**





EMERGENCY

# Central Supply Systems

# CSS



Tower

**1:1** **3:1** 6-15 kVA

**3:3** 10-100 kVA

**EN50171**  
CERTIFIED

PRODUCTS  
VERIFIED BY  
**IMQ**



## HIGHLIGHTS

### CERTIFIED COMPLIANCE WITH STANDARD EN 50171

Ideal for emergency lighting and alarm systems.

### DUAL INPUT

Simplicity and safety for the periodical system operation check.

### PROTECTION AGAINST BATTERY INVERSION

Protection for emergency services and safety for operators.

### HIGH RECHARGE CURRENT

Reduced recharge times.

### CONTINUOUS OVERLOAD OF 120%

Large power reserve.

### CASING COMPLIANT WITH STANDARD EN 60598-1

High mechanical protection.

### BATTERIES WITH 10 YEAR LIFE

Long battery life.

The CSS (Central Supply Systems) range by Riello UPS is certified and designed in compliance with standard EN 50171 and is therefore the ideal solution for installation in buildings subject to fire safety regulations and in particular for the power supply of emergency lighting systems. In addition the CSS range by Riello UPS is also suitable for supplying power to other emergency systems such as automatic fire extinguishing systems, alarm systems and emergency detection systems, smoke extraction equipment and carbon monoxide detection devices as well as dedicated security systems in sensitive areas.

The use of centralised supply systems (CSS) ensures a significant reduction in system set-up and maintenance costs as well as making periodical checks simpler and faster to perform.

### Dual input

The Riello UPS CSS range is equipped with DUAL INPUT as standard on all models. This important feature allows the mandatory scheduled checks on system operation and

autonomy to be carried out with extreme ease and in complete safety by simply operating an input switch. This switch interrupts the power supply to the machine without interrupting the bypass line, which is able to support the load in the event of test failure.

### High recharge current and battery care system

Proper battery care is critical to ensuring correct CSS operation in emergency conditions.

The Riello UPS battery care system consists of a series of features and capabilities designed to obtain the best performance, extend operating life and satisfy the recharge times imposed by the standard. The Riello UPS CSS range is designed in compliance with standard EN 50171 and ensures high current levels are available for the batteries, allowing recharge of up to 80% of full autonomy within 12 hours. Riello UPS CSS are suitable for use with hermetically sealed lead-acid (VRLA), AGM and GEL batteries and Open Vent and Nickel





Cadmium batteries. Different charging methods are available depending on the battery type.

The recharge voltage compensation function based on temperature prevents excessive battery charges and overheating.

The deep discharge protection prevents reduced battery performance and battery damage.

### High Overload Capacity

As required by standard EN 50171, the Riello UPS CSS range is designed and sized to support continuous overloads (with no time limits) of up to 120% of the machine's nominal power rating.

### Protection Against Battery Inversion

Mandatory in line with standard EN 50171, protection against battery inversion ensures the safety of those carrying out maintenance operations on the devices and at the same time prevents damage to the system in the event that the batteries are inadvertently connected with the wrong polarity.



### General features

In addition to the features mentioned here, the Riello UPS CSS range has all the features of reliability and flexibility common to the UPS range it derives from, as well as offering compatibility with the main options and accessories.

## OPERATING MODE

Every Riello CSS model supports all the operating modes set out and described in standard EN50171, as below:

### A Changeover mode

The load is supplied via the CSS bypass line (always supplied output "AS").

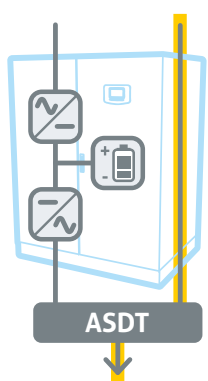

In the event of power supply failure the internal automatic device (ATSD) transfers the load to the inverter. The battery provides power to the inverter, ensuring the required runtime.

### B Mode without interruption

The load is supplied constantly by the CSS inverter (always supplied output "AS").

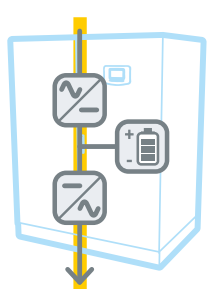

In the event of power supply failure the battery provides power to the inverter, ensuring the required runtime with no interruptions at all.

### C Changeover mode with additional control switching device for control switching of the load

In addition to that described in points A and B, the equipment includes one or more switching devices (CSD), which rely on the availability of the normal power supply. On power supply failure the CSD device connects the load that up until that moment was not supplied (emergency only output "EO").

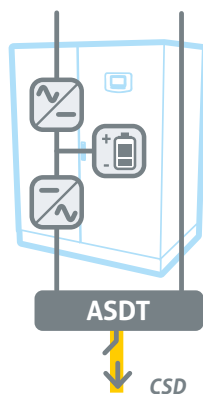

### D Changeover mode with additional control switching device for partial switching of the load

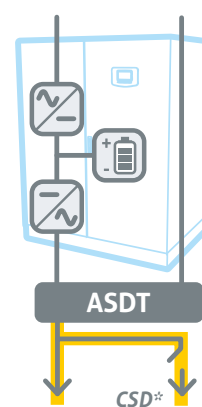

Differently to that described in point C, part of the load is supplied without interruption whilst the remaining part is only supplied upon power supply failure thanks to the CSD device (always supplied + emergency only output "AS+EO").

\*Requires EOS optional accessory

### EOS optional accessory

The EOS (Emergency Only Switch) accessory is required whenever one part of the load must always be supplied (always supplied output "AS"), and one part must be supplied only when mains power fails (emergency only

output "EO"), in order to create the operating mode described in point D. By connecting several EOS accessories in a cascade configuration it is also possible to provide for the sequential delayed switching on of loads in order to reduce inrush switching on currents.







# Transfer Systems



DATACENTRE

# Multi Switch

**1:1** 16 A



Plug & Play installation



## HIGHLIGHTS

- Redundant power supply
- Load protection
- Versatile to use

The Riello UPS Multi Switch is a high availability and versatile intelligent switch that provides redundant power to connected equipment with two AC input sources. The Riello UPS Multi Switch supplies power to the connected loads from a primary mains source. If that primary source becomes unavailable, the Riello UPS Multi Switch automatically transfers loads to the secondary source. The transfer time from one source according the ITI (CBEMA) chart does not impact the operation of the connected equipment as the switching occurs safely between the two input sources regardless of any phase differences. The Riello UPS Multi Switch monitors the current and provides warnings when power consumption draws near the maximum rating which helps prevent downtime to the equipment. Riello UPS Multi Switch has 8 independent IEC 10 A outlets allowing several devices can be plugged directly into the Rack without the need for an additional Rack PDU. The units have a connectivity slot which allows for LAN connection and remote management through PowerShield<sup>3</sup> software, Web interface, SNMP,

or SSH which makes the Riello UPS Multi Switch an ideal device for the IT manager who needs flexibility and protection for their IT equipment.

Multi Switch provides installations with power supply continuity. Its operating principle ensures higher reliability than a single UPS, (with or without its own internal bypass).

### Operating principle

Multi Switch provides direct distribution of eight 10 A IEC outlets in a system with two input powerlines (two mains inputs, or two UPS). Multi Switch is able to connect to either of the two input power lines, whilst simultaneously monitoring the power uptake.

### Protection against load faults

If one of the loads fails (e.g. short circuit), Multi Switch disconnects the group of sockets where the load is connected, thus preventing other loads from being switched off (i.e. in the event of poor discrimination of the protection devices).

### Protection against power supply faults

If one of the two power sources falls outside tolerance levels, Multi Switch will transfer the load to the second powersource (switching is instantaneous if the two sources are in phase). Multi Switch units switch power with no impact to IT equipment. Depending on the ITI Curve, typical power supplies will operate 20 ms after AC voltage drops to zero. The IEEE 1100-1999 standard also references the ITI

curve. The SSI (Server System Infrastructure) standard recommends a hold-up time for power supplies to be a minimum of 21 ms for a voltage range of 100-240 V.

Multi Switch units switch sources under these industry standard times.

The switching time includes the time for the built-in intelligence to determine whether the voltage and frequency are in range. Any point

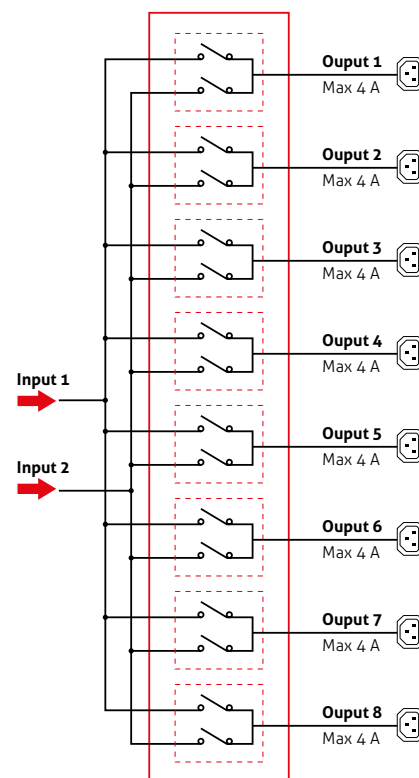



of failure in the electronics does not cause a drop out of the output voltage because the unit incorporates redundancy of its electronic circuitry to avoid fault tolerance.

### Features

- Full protection for loads against mains and load failures
- Redundant power supply
- Versatile to use: Multi Switch can be powered with 2 different power supplies (including 2 UPS of different sizes/types)
- 19" cabinet installation
- LCD Display panel
- Can be connected to PowerNetGuard supervision software
- No signal connection between the Multi Switch and the power sources or loads is necessary
- Slot for communications boards: the optional network card allows for remote in network connectivity, and management through HTTP, SNMP, and SSH protocol.

## DETAILS

### MSW (2 inputs - 8 outputs)

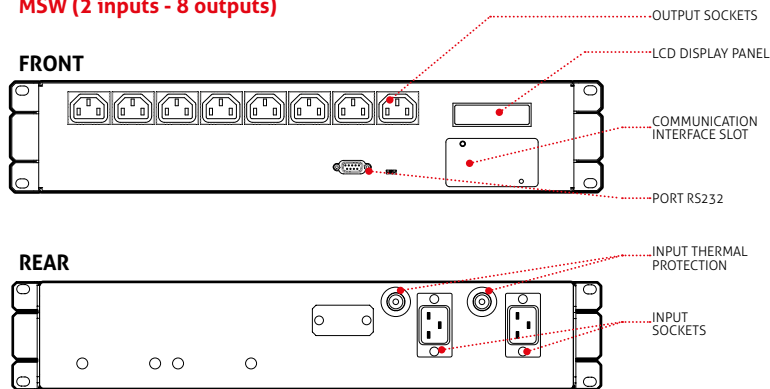

## OPTIONS

### SOFTWARE

PowerNetGuard

### ACCESSORIES

NETMAN 204

MODELS	MSW
<b>NOMINAL CURRENT (A)</b>	<b>16</b>
<b>INPUT</b>	
Nominal voltage - sources S1/S2	230 Vac single-phase + N
Voltage tolerance	180-276 Vac (selectable)
Switched input phases	ph+N (two poles)
Nominal frequency	50/60 Hz
Input sockets	2 IEC 320 (16 A)
<b>OPERATING SPECIFICATIONS</b>	
Transfer type	"Break Before Make" (no overlapping sources)
Transfer time following source failure	< 8 msec (S1/S2 synchronised)    20 msec (S1/S2 non synchronised)
<b>OUTPUT</b>	
Nominal voltage	choice of one of the two input power sources
Max. load for each output	4 A
Output sockets	8 IEC 320 10 A
<b>ENVIRONMENTAL SPECIFICATIONS</b>	
Efficiency at full load	> 99%
Noise at 1 m from front (from 0 to full load)	< 35 dBA
Storage temperature	-10 °C up to +50 °C
Operating temperature	0 °C - 40 °C
Relative humidity	90% non-condensing
Max. installation height	1000 m at nominal power (-1% power for every 100 m above 1000 m) - Max 4000 m
Reference standard	EN 62310-1 (safety) EN 62310-2 (electro-magnetic compatibility)
<b>INFO FOR INSTALLATION</b>	
Weight (kg)	10
Dimensions (WxDxH) (mm)	19" x 360 x 2U
Colour	RAL 5004
IP rating	IP 20
Communications	RS232 / Slot for communication interface



DATACENTRE

# Multi Switch ATS

**1:1** 16 A



**Plug & Play**  
installation



## HIGHLIGHTS

- **Redundant power supply**
- **Load protection**
- **Versatile to use**

The RIELLO UPS Multi Switch ATS is a high availability intelligent switch that provides redundant power to connected equipment with two AC input sources. The RIELLO UPS Multi Switch ATS supplies power to the connected loads from a primary mains source. If that primary source becomes unavailable, the RIELLO UPS Multi Switch automatically transfers loads to the secondary source. The transfer time from one source according to the ITI (CBEMA) chart does not impact the operation of the connected equipment as the switching occurs safely between the two input sources regardless of any phase differences. The RIELLO UPS Multi Switch ATS monitors the current and provides warnings when power consumption draws near the maximum rating which helps prevent downtime to the equipment.

RIELLO UPS Multi Switch ATS has 8 IEC 10 A and 1 IEC 16 A outlets allowing several devices to be plugged directly into the ATS without the need for an additional PDU. The units have a connectivity slot which allows for LAN connection and remote management through PowerShield<sup>3</sup> software, Web

interface, SNMP, or SSH which makes the RIELLO UPS Multi Switch ATS an ideal device for the IT manager who needs flexibility and protection of their IT equipment. Multi Switch ATS provides installations with power supply continuity. Its operating principle ensures higher reliability than a single UPS, (with or without its own internal bypass).

### Operating principle

Multi Switch ATS provides direct distribution of eight 10 A IEC outlets or one 16 A IEC outlet in a system with two input powerlines (two mains inputs, or two UPS). Multi Switch ATS is able to connect to either of the two input power lines, whilst simultaneously monitoring the power uptake.

### Protection against load faults

If one of the loads fails (e.g. short circuit), the Multi Switch ATS disconnects the group of sockets where the load is connected, thus preventing other loads from being switched off (i.e. in the event of poor discrimination of the protection devices).

### Protection against power supply faults

If one of the two power sources falls outside tolerance levels, Multi Switch ATS will transfer the load to the second powersource (switching is instantaneous if the two sources are in phase).

Multi Switch ATS units switch power with no impact to IT equipment. Depending on the ITI Curve, typical power supplies will operate

20 ms after AC voltage drops to zero. The IEEE 1100-1999 standard also references the ITI curve. The SSI (Server System Infrastructure) standard recommends a hold-up time for power supplies to be a minimum of 21 ms for a voltage range of 100-240 V. Multi Switch ATS units switch sources under these industry standard times. The switching time includes the time for the built-in intelligence to determine whether the voltage and frequency are in range. Any point of failure in the electronics does not cause a drop out of the output voltage because the unit incorporates redundancy of its electronic circuitry to avoid fault tolerance.

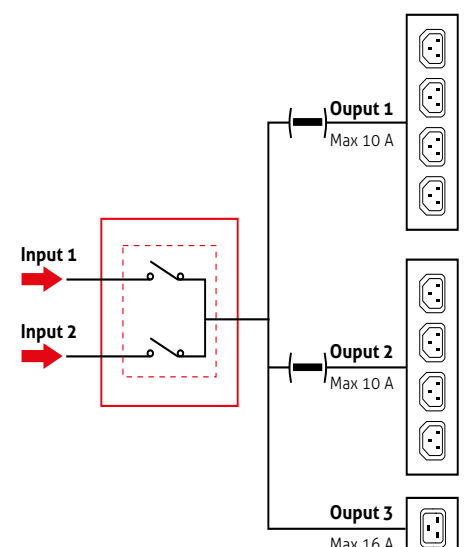

## Features

- Full protection for loads against mains and load failures
- Redundant power supply
- Versatile to use: Multi Switch ATS can be powered with 2 different power supplies (including 2 UPS of different sizes/types)
- 19" cabinet installation
- Display panel
- Can be connected to PowerNetGuard supervision software
- No signal connection between the Multi Switch ATS and the power sources or loads is necessary
- Compatible with PowerShield<sup>3</sup> software
- Slot for communications boards: the optional network card allows for remote in network connectivity, and management through HTTP, SNMP, and SSH protocol.

## DETAILS

### MTA

#### FRONT

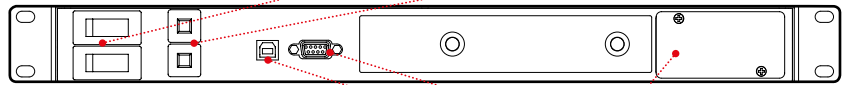

#### REAR

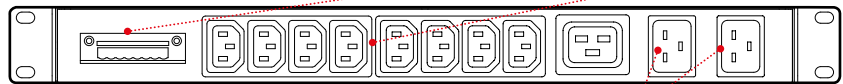

## OPTIONS

### SOFTWARE

PowerShield<sup>3</sup>

### ACCESSORIES

NETMAN 204

MULTICOM 302

MULTICOM 352

MODELS	MTA	
<b>NOMINAL CURRENT (A)</b>	<b>16</b>	
<b>INPUT</b>		
Nominal voltage - sources S1/S2	230 Vac single-phase + N	
Voltage tolerance	180-276 Vac (selectable)	
Switched input phases	ph+N (two poles)	
Nominal frequency	50/60 Hz	
Input sockets	2 IEC 320 (16 A)	
<b>OPERATING SPECIFICATIONS</b>		
Transfer type	"Break Before Make" (no overlapping sources)	
Transfer time following source failure	< 8 msec (S1/S2 synchronised)    20 msec (S1/S2 non synchronised)	
<b>OUTPUT</b>		
Nominal voltage	choice of one of the two input power sources	
Max. load for each output	10 A on IEC-320 C13 - 16 A on IEC-320 C19	
Output sockets	4+4 IEC-320 C13 (10 A) + 1 IEC-320 C19 (16 A)	
<b>ENVIRONMENTAL SPECIFICATIONS</b>		
Efficiency at full load	> 99%	
Noise at 1 m from front (from 0 to full load)	< 35 dBA	
Storage temperature	-10 °C up to +50 °C	
Operating temperature	0 °C - 40 °C	
Relative humidity	90% non-condensing	
Max. installation height	1000 m at nominal power (-1% power for every 100 m above 1000 m) - Max 4000 m	
Reference standard	EN 62310-1 (safety) EN 62310-2 (electro-magnetic compatibility)	
<b>INFO FOR INSTALLATION</b>		
Weight (kg)	6	
Dimensions (WxDxH) (mm)	19" x 330 x 1U	
Colour	RAL 5004	
IP rating	IP 20	
Communications	RS232 / USB / Slot for communication interface / Relay contacts port	

# Master Switch STS *Single-phase*



DATACENTRE



E-MEDICAL



INDUSTRY



TRANSPORT

**1:1** 32-63-120 A



**Plug & Play**  
installation

## HIGHLIGHTS

- **Operating flexibility**
- **Load protection**
- **Complete diagnostics**
- **Hot Swap function**

Master Switch Single-phase (MMS) is part of the Master Switch range and offers solutions suitable for protecting single-phase loads with different power ratings. MMS is available in three sizes - 32, 63 and 120 A - and is therefore able to satisfy various requirements for the protection of single-phase loads.

### Flexibility of use

All MMS versions are designed with criteria that facilitate on-site installation as well as diagnostics, control and maintenance operations. All models are equipped with a manual bypass and the hot swap function allows for rapid corrective interventions by non-specialised personnel in the event of faults.

### Load protection

With MMS transfer switch loads are protected against critical environmental situations and mains power interference. Microprocessor control and the use of thyristor static switches ensure continuous monitoring of the power supply sources and reduced switching times between the two sources in the event of a fault.

The constant monitoring of the output current allows for the rapid identification of any short circuit currents in the consumers, preventing short circuits from propagating to other loads.

MMS is equipped with thermal-magnetic protection for the two sources, ensuring rapid intervention in the event of faults and integrated back feed protection.

MMS ensures switching times between the two power sources of less than a quarter of a cycle, both in the event of manual switching and in the event automatic switching triggered by a fault in the power source.

### Complete diagnostics

All MMS versions are equipped with 32-character LCD displays and control panels with multi-function keys. This allows for rapid and intuitive monitoring of supply readings, switch status and environmental conditions. MMS is equipped with three standard programmable dry contacts, an input for emergency shutdown, a RS232 serial connection and a slot for housing the expansion board, thus ensuring complete availability of interface solutions for remote control and monitoring.



MODELS	MMS 32	MMS 63	MMS 120
<b>NOMINAL CURRENT (A)</b>	<b>32</b>	<b>63</b>	<b>120</b>
<b>INPUT</b>			
Nominal voltage - sources S1/S2	220 - 230 - 240 Vac single-phase + N		
Voltage tolerance	180-264 Vac (selectable)		
Switched input phases	ph+N (two poles)		
Nominal frequency	50/60 Hz		
Input frequency tolerance range	+/-10% (selectable)		
Distribution compatibility	IT, TT, TNS, TNC		
<b>OPERATING SPECIFICATIONS</b>			
Transfer type	"Break Before Make" (no overlapping sources)		
Intervention method in the event of failure	hot swap function		
Available transfer methods	Automatic / Manual / Remote		
Transfer time following source failure	< 4 msec (S1/S2 synchronised) 10 msec (S1/S2 non synchronised)		
<b>ENVIRONMENTAL SPECIFICATIONS</b>			
Efficiency at full load	> 99%		
Noise at 1 m from front (from 0 to full load)	< 40 dBA		
Storage temperature	-10 °C up to +50 °C		
Operating temperature	0 °C - 40 °C		
Relative humidity	90% non-condensing		
Max. installation height	1000 m at nominal power (-1% power for every 100 m above 1000 m) - Max 4000 m		
Reference standard	EN 62310-1 (safety) EN 62310-2 (electro-magnetic compatibility)		
<b>INFO FOR INSTALLATION</b>			
Weight (kg)	10	12	20
Dimensions (WxDxH) (mm)	19" x 520 x 2U		19" x 520 x 3U
Colour	RAL 7016		
IP rating	IP 20		

## OPTIONS

### SOFTWARE

PowerShield<sup>5</sup>  
PowerNetGuard

### ACCESSORIES

NETMAN 204  
MULTICOM 302  
MULTICOM 352

## DIAGRAM

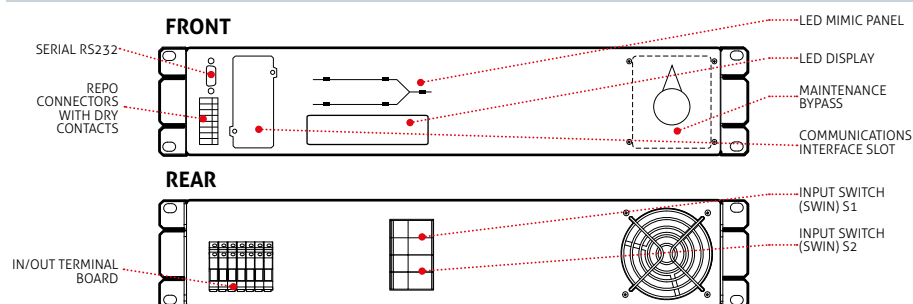

Hot swap replacement:



Carry out manual bypass operation on faulty unit selecting S1 or S2



Remove the screws placed on left/right side and extract the unit



Replace the faulty unit with a new one

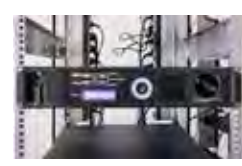

Fix the parts, follow start up procedure and return back from manual bypass

All operations are carefully described on operating manual.



DATA CENTRE



E-MEDICAL



TRANSPORT



EMERGENCY

# Master Switch STS *Three-phase*

**3:3** 100-800 A



Service  
1st start

## HIGHLIGHTS

- High reliability
- Hot Replacement function
- 3- or 4-pole version
- Advanced communications

Installing a Master Switch static transfer switch provides additional resilience and protection from the disruption that can be caused by the failure of a single power source.

The result is the absolute protection of industrial utilities and critical information technology against power supply and load faults.

### Operating principle

Master Switch guarantees a source of redundant power, allowing the load to be switched between to alternative and independent power sources. Switching can be automatic (when a supply source falls outside of acceptable

tolerances) or manually done by an operator from the front panel or remotely.

### Protection against power supply faults

If one of the two power sources falls outside tolerance levels, Master Switch will transfer the consumers to the second power source (switching is instantaneous if the two sources are in phase).

### Protection against environmental disturbances

#### Overloads and load faults

In the event of an overload, the user can decide the level of intervention of the internal protection devices in order to block

the power supply. In the extreme case of a downstream short circuit, Master Switch disconnects the load in order to avoid jeopardising the operation of the other loads (i.e. in the event of poor selectivity of the protection devices).

### Total microprocessor control

Microprocessor control logic ensures:

- Fast and safe switching between power sources
- Monitoring of all parameters via LCD display
- Constant monitoring of SCR operation
- Advanced remote diagnostics (RS232 and TCP/IP).

### Redundant design

Power is supplied to the internal logic by two physically separate supply circuits that are fully independent and that can be replaced in **"hot replacement"** mode without causing power supply interruptions to the load. In the event that the power supplied by both sources fails, full system operation is guaranteed by the **"Power Supply back up"** function, which provides auxiliary power supply to the circuits from an external, independent power source. Master Switch is equipped with a dual redundant ventilation system known as: **"fan redundancy plus"**. Thanks to this feature, and in the unlikely event that two fans fail at the same time, those remaining would still be able to dissipate the heat generated at nominal load and with an ambient temperature of up to 40° C. Also the fans can be replaced in **"hot replacement"** mode, ensuring continuity during the replacement operation.

### Superior protection

In the event of an output short circuit, Master Switch blocks the transfer between the two power sources, eliminating the risk of propagating the short circuit and its effects to the other loads. A back feed control circuit ensures the

automatic intervention of the protection devices when a return of power to one of the two Master Switch inputs is detected.

### Accessibility

The layout of the moving components and parts is designed to ensure easy frontal access:

- power cable connections that are easily accessed with entry from below
- boards housed in a dedicated area for rapid diagnosis / replacement
- all parts subject to monitoring, maintenance and/or replacement.

### Advanced communications

Master Switch provides information, measurements, statuses, and alarms via the LCD display. The STS is compatible with PowerShield<sup>3</sup> supervision and shutdown software for Windows operating systems 10, 8, 7, Hyper-V, 2016, 2012, and previous versions, Mac OS X, Linux, VMWare ESXi, Citrix XenServer and other Unix operating systems.

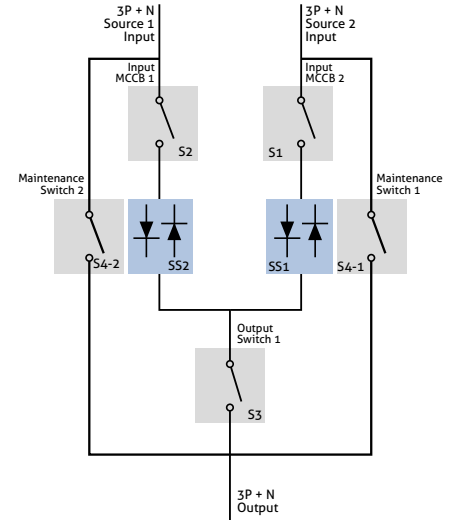

### OPTIONS

#### SOFTWARE

PowerShield<sup>3</sup>

#### ACCESSORIES

NETMAN 204  
+ Communication card adapter

MULTICOM 302  
+ Communication card adapter

MULTICOM 352  
+ Communication card adapter

#### PRODUCT ACCESSORIES (ALL EX-WORK)

"No neutral on input" kit

IP rating IP31

Power Supply Back-up

### DIMENSIONS

**MTS 100**  
**MTS 150**

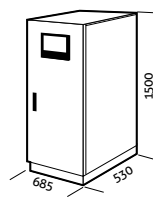

**MTS 200 - MTS 250**  
**MTS 300 - MTS 400**

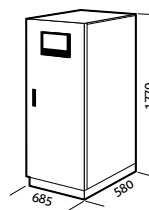

**MTS 600**

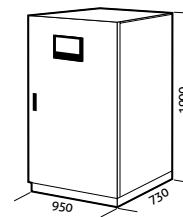

**MTS 800**

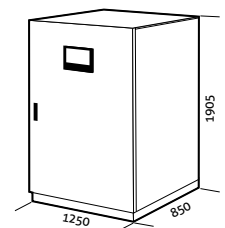

LEDs	FUNCTION
L1	S1 Priority Source
L2	S2 Priority Source
L3	S1 Present
L4	S2 Present
L5	Static transfer switch SS1 closed
L6	Static transfer switch SS2 closed
L7	Alarm indicator
L8	Output selector ON/OFF

**5 function keys and LCD operation**

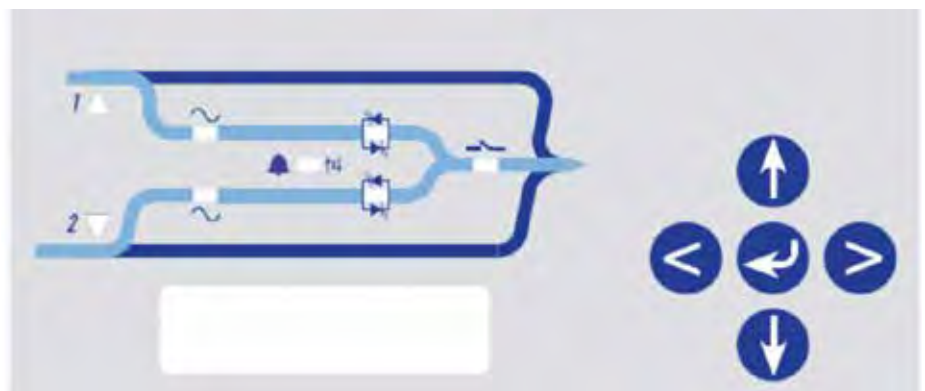

## MASTER SWITCH IN REDUNDANT MODE

The secondary power source [AS], although highly reliable, only powers the load in the event of a failure with the priority power source [PS], ensuring maximum redundancy and power quality to the loads.

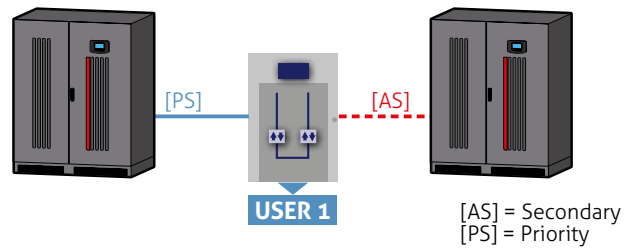

## MASTER SWITCH IN CROSS FEEDING MODE

The two sources power critical loads using Master Switches configured to selected one of the two power sources as the priority source [PS]. In case of a failure in one of two sources, the other will be able to supply power to all the loads connected to the system).

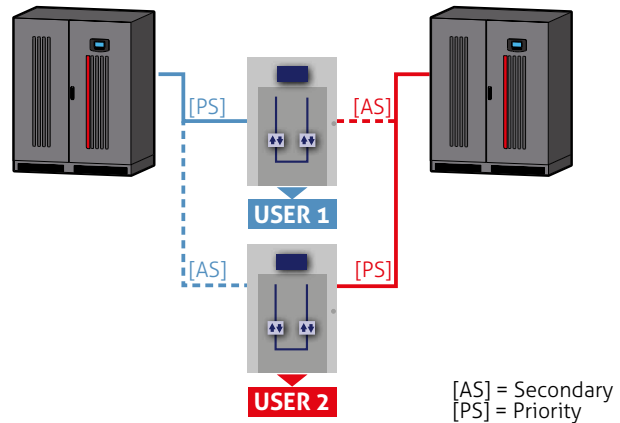

## MASTER SWITCH IN BACK-UP MODE

Master Switches power utilities via the priority energy source [PS]; the secondary energy source [AS] is made up of independent, separate power sources and to make up for any faults in the priority power source [PS].

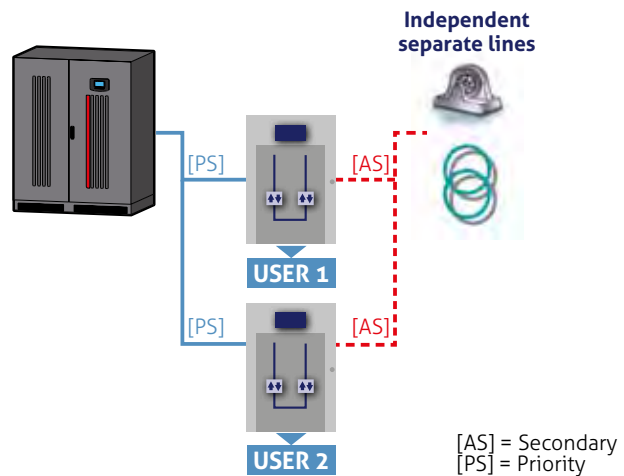

## DYNAMIC DUAL BUS CONFIGURATION

The Riello UPS solution guarantees maximum reliability and ensures continuity of power supply under all operating conditions thanks to the UGS option that keeps the two systems, A and B, perfectly synchronised.

The flexibility of the UGS system ensures synchronism between the sources even when one of the two systems is not a Riello UPS model, but made by another manufacturer, or when the input sources are not from uninterruptible power supplies.

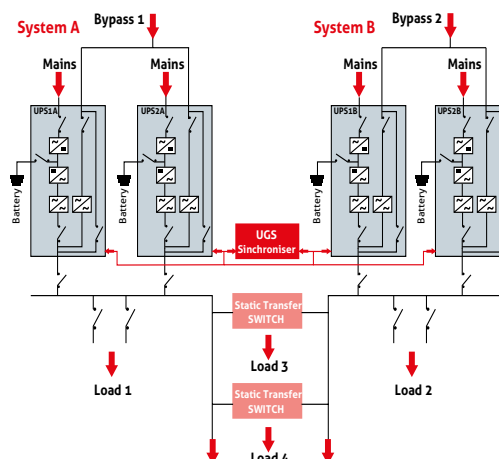



MODELS	MTS 100	MTS 150	MTS 200	MTS 250	MTS 300	MTS 400	MTS 600	MTS 800	
<b>NOMINAL CURRENT</b>	<b>100 A</b>	<b>150 A</b>	<b>200 A</b>	<b>250 A</b>	<b>300 A</b>	<b>400 A</b>	<b>600 A</b>	<b>800 A</b>	
<b>INPUT</b>									
Nominal voltage - sources S1/S2	380 - 400 - 415 Vac three-phase + N								
Voltage tolerance	180 - 264 Vac (selectable)								
Switched input phases	3+N (4-pole) - 3 (3-pole)								
Nominal frequency	50/60 Hz								
Input frequency tolerance range	+/-10% (selectable)								
Distribution compatibility	IT, TT, TNS, TNC								
<b>OPERATING SPECIFICATIONS</b>									
Transfer type	"Break Before Make" (no overlapping sources)								
Available transfer methods	Automatic / Manual / Remote								
Transfer time following source failure	< 4 msec (S1/S2 synchronised) 10 msec (S1/S2 non synchronised)								
<b>ENVIRONMENTAL SPECIFICATIONS</b>									
Efficiency at full load	> 99%								
Noise at 1 m from front (from 0 to full load)	55 dBA	55 dBA	55 dBA	55 dBA	55 dBA	55 dBA	< 60 dBA	< 62 dBA	
Storage temperature	-10 °C up to +50 °C								
Operating temperature	0 °C - 40 °C								
Relative humidity	90% non-condensing								
Max. installation height	1000 m at nominal power (-1% power for every 100 m above 1000 m) - Max 4000 m								
Reference standard	EN 62310-1 (safety) EN 62310-2 (electro-magnetic compatibility)								
<b>INFO FOR INSTALLATION</b>									
Weight (kg) 3 pole Type	145	165	195	205	230	240	365	515	
Weight (kg) 4 pole Type	175	190	205	235	240	255	375	560	
Dimensions (WxDxH) (mm)	685 x 530 x 1500		685 x 580 x 1770				950 x 730 x 1900	1250 x 850 x 1905	
Colour	RAL 7024								
IP rating	IP 20								
Moving the STS	Pallet Jack								







# Power Solutions

# Power solutions

## SuperCaps UPS

SOLUTIONS WITH SUPERCAPS



DATA CENTRE



E-MEDICAL



INDUSTRY

**1:1** 2-10 kVA

**3:3** 10-125 kVA



ONLINE

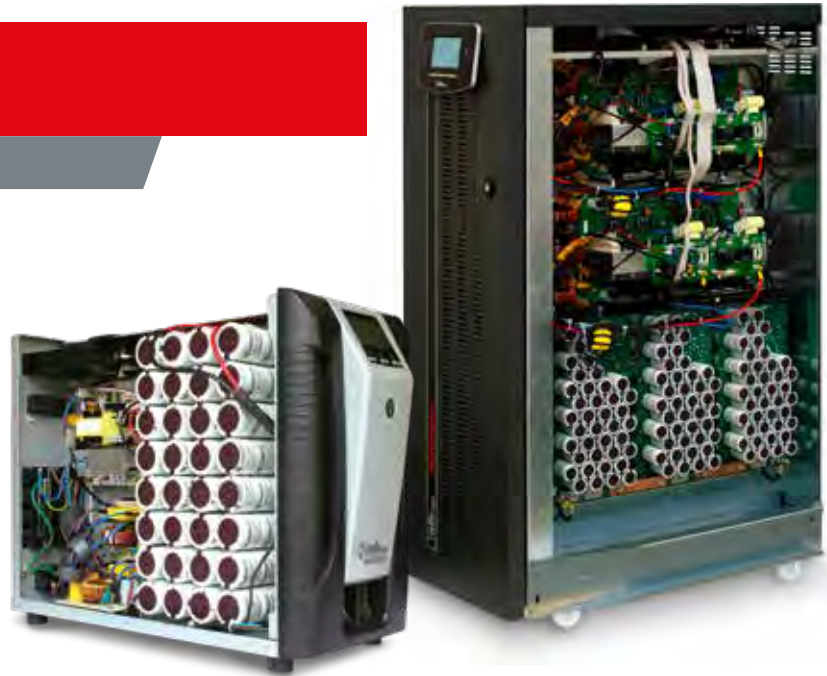

### HIGHLIGHTS

#### CLEAN ENERGY

An eco-friendly, battery-free uninterruptible power system.

#### HIGH EFFICIENCY INNOVATIVE TECHNOLOGY

Modular expansion options for more power and runtime.

#### LONG OPERATING LIFE

5 to 10 times standard lead batteries

#### HIGH NUMBER OF CYCLES

Million vs. ca 300 of lead batteries

#### LOW MAINTENANCE COSTS

Easy to install and maintain.

#### HIGH WORKING TEMPERATURE

No need of cooling or heating systems

#### LOW FOOTPRINT & WEIGHT

SuperCaps module



SuperCaps UPS are a type of uninterruptible power supply developed by Riello UPS, which use super capacitors to accumulate energy instead of conventional batteries. Autonomy in the range of seconds (1 to 60 sec). The innovative Riello SuperCaps UPS are designed to provide complete power supply protection for sensitive and mission-critical loads, protecting them from mains disturbances and providing sufficient power to compensate for interruptions in mains supply.

Traditionally UPS rely on batteries for accumulating energy, but at least 87% of power supply interruptions last for less than a second<sup>(1)</sup>. SuperCaps UPS provide greater energy efficiency, lower costs and reduced footprints – ideal for installations where floor space is at a premium.

At the heart of the Riello SuperCaps UPS is a sophisticated control system that manages the charge-discharge cycle of the super-capacitors and optimises their lifecycle, which may exceed a million cycles. Their back-up time is dependent on the load but is sufficient to supply it until the mains power is restored or until reserve power from a generator starts automatically.

Most UPS are installed as standard with batteries lasting 5-10 minutes to protect the load against generator start up failure. For modern data centres, electro-medical and industrial applications, an efficient generator set supported by a UPS with a relatively brief autonomy offers the most efficient and effective power continuity solution, with conventional batteries providing sufficient runtime to cover most power interruptions.

However, SuperCaps UPS do not have batteries and therefore provide long term savings in terms of battery installation, monitoring, maintenance, replacement and recycling costs. In addition, when compared to the 5-7 year lifecycle of standard batteries, SuperCaps UPS have a theoretically infinite lifecycle. These cost savings, along with the reduced footprint make SuperCaps UPS the ideal solution for critical installations that are particularly sensitive to short power supply interruptions.

<sup>(1)</sup> Electric Power Research Institute study





# Power solutions

## Master VDC

### FLYWHEEL SOLUTIONS



DATACENTRE



E-MEDICAL



INDUSTRY



TRANSPORT



EMERGENCY

**3:3** 100-600 kVA



ONLINE



Flywheel compatible



SmartGrid ready



Service 1st start

### HIGHLIGHTS

#### CLEAN ENERGY

An eco-friendly, battery-free uninterruptible power system.

#### HIGH EFFICIENCY INNOVATIVE TECHNOLOGY

Modular expansion options for more power and runtime.

#### LONG OPERATING LIFE

20 year design life for the flywheel component compared with 7 years for a typical battery.

#### LOW MAINTENANCE COSTS

Easy to install and maintain.



Master VDC is a scalable system comprised of one or more UPS units and VDC-XE/ VDC-XXE flywheels. Master VDC is ideal for modern ECO targeted data centres looking to achieve the lowest possible PUE ratios and highest levels of reliability. Master VDC UPS provide a number of advantages over more traditional battery-equipped systems including: up to 99% efficiency, a compact footprint (up to 50% reduction), lower Total Cost of Ownership (TCO) and almost instantaneous recharge times. A single flywheel module provides sufficient runtime for the start-up of a local standby generator to power the UPS, which then provides a continuous quality power supply. The entire system can be scaled for reliable power (N+x) and increased runtime via the parallel operation of several UPS and/or flywheel modules (and a small battery pack if required, for additional reliability). In a standard configuration (1 x UPS and 1 x flywheel), the runtime available

is more than sufficient to allow the UPS to ride through short breaks in mains power.

#### Flywheel VDC-XE/VDC-XXE

Thanks to their extremely high levels of reliability, the VDC series of flywheel energy storage systems provide UPS with a secure and reliable source of power that forms the first line of defence against interruptions to the mains power supply; a fundamental defence for all mission critical applications. The VDC flywheel systems are fully independent standalone devices. They are designed for applications such as data centres, hospitals and industrial installations. They provide a clean source of back up power by converting the kinetic energy stored within a rotating mass into electrical power using a built-in IGBT-based converter.

VDC series flywheels store kinetic energy in the form of a rotating mass (spinning at 36000 RPM) within a vacuum-sealed



## MASTER VDC CONFIGURATION EXAMPLES

### MODULARITY

**MHF 100**

100 kVA UPS + VDC-XE FLYWHEEL + VDC-XE FLYWHEEL

**Autonomy:**  
example with load at 100%:  
42 s, 1xVDC-XE  
82 s, 2xVDC-XE

**MHF 300**

300 kVA UPS + VDC-XE FLYWHEEL + VDC-XE FLYWHEEL

**Autonomy:**  
example with load at 50%:  
27 s, 1xVDC-XE  
54 s, 2xVDC-XE

### REDUNDANCY (PARALLEL CONFIGURATIONS N+1)

**MHF 300P**

300kVA UPS + 300kVA UPS + VDC-XE FLYWHEEL + VDC-XE FLYWHEEL

N+1 Parallel UPS Configuration

**Autonomy:**  
example with load at 50%:  
54 s, 2xVDC-XE  
or 27 s, 1xVDC-XE

### BATTERY HARDENING

**MHF 300**

300 kVA UPS + VDC-XE FLYWHEEL + BATTERY BOX

**Autonomy:**  
example with load at 50%:  
27 s, 1xVDC-XE  
Plus 10 minutes from an additional battery set

container. The VDC build technology includes a rotor made from aerospace-grade steel, a high speed permanent magnet motor/generator and contact-free magnetic bearings that levitate and sustain the rotor during operation with no mechanical friction. These technical features allow VDC models to achieve very high levels of efficiency.

### DIMENSIONS

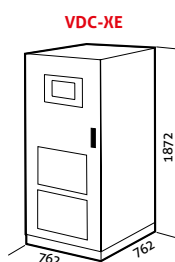

## MASTER VDC: UPS MODULE SPECIFICATIONS

MODELS	MHF 100	MHF 120	MHF 160	MHF 200	MHF 250	MHF 300	MHF 400	MHF 500	MHF 600
<b>INPUT</b>									
Nominal voltage	380 - 400 - 415 Vac three-phase								
Frequency	45 - 65 Hz								
Power factor	> 0.99								
Harmonic current distortion	<3% THDi								
Soft start	0 - 100% in 120" (selectable)								
Frequency tolerance	± 2% (selectable from ± 1% to ± 5% from front panel)								
Standard equipment provided	Back Feed protection; separable bypass line								
<b>BATTERIES</b>									
Type	Flywheels								
Ripple current	Zero								
Recharge voltage compensation	-0.5 Vx°C								
<b>OUTPUT</b>									
Nominal power (kVA)	100	120	160	200	250	300	400	500	600
Active power (kW)	90	108	144	180	225	270	360	450	540
Number of phases	3 + N								
Nominal voltage	380 - 400 - 415 Vac three-phase + N								
Static stability	± 1%								
Dynamic stability	± 5% in 10 ms								
Voltage distortion	< 1% with linear load / < 3% with non-linear load								
Crest factor	3:1 I <sub>peak</sub> /I <sub>rms</sub>								
Frequency stability on battery	0.05%								
Frequency	50 or 60 Hz (selectable)								
Overload	110% for 60 minutes; 125% for 10 minutes; 150% for 1 minute								
<b>INFO FOR INSTALLATION</b>									
Weight (kg)	656	700	800	910	1000	1400	1700	2100	2400
Dimensions (WxDxH) (mm)	800 x 850 x 1900		1000 x 850 x 1900			1500 x 1000 x 1900		2100 x 1000 x 1900	
Remote signals	dry contacts (configurable)								
Remote controls	ESD and bypass (configurable)								
Communications	Double RS232 + dry contacts + 2 slots for communications interface								
Ambient temperature	0°C / +40°C								
Relative humidity	<95% non-condensing								
Colour	Dark grey RAL 7016								
Noise level at 1 m	63 - 68 dBA				70 - 72 dBA			70 dBA	70 dBA
IP rating	IP20 (others on request)								
Smart Active efficiency	up to 98.5%								
Standards	Safety: EN 62040-1-1 (Directive 2006/95/EC); EMC: EN 62040-2 (Directive 2004/108/EC)								
Classification in accordance with IEC 62040-3	(Voltage Frequency Independent) VFI - SS - 111								
Moving the UPS	transpallet								

## MASTER VDC: FLYWHEEL MODULE SPECIFICATIONS

MODEL	VDC-XE	VDC-XXE
<b>POWER</b>		
Maximum power	300 kW	
Max. energy storage	4000 kW <sub>s</sub>	6000 kW <sub>s</sub>
Flywheel rotation speed	from 36750 to 24500 rpm	from 36750 to 1400 rpm
<b>INPUT</b>		
Recharge voltage	400-600 Vdc	
Recharge current	15-50 A (adjustable)	
Efficiency	99.4%	
<b>OUTPUT</b>		
Discharge voltage	400-520 Vdc (adjustable)	
Voltage stability	+/- 1%	
Voltage ripple	≤ 2%	
<b>INFO FOR INSTALLATION</b>		
Ambient temperature	-10°C / +40°C	
Relative humidity	90% non-condensing	
Colour	Dark grey RAL 7016	
Noise level at 1 m	≤ 68 dBA	
Dimensions (WxDxH) [mm]	762 x 762 x 1872	
Weight [kg]	821	
IP rating	IP 20	
Standards	EMC EN 61000-6-4:2001; EMC EN 61000-6-2:2001; Safety EN 60204-1; Directives: 2004/108/EC; 98/37/EC	



## MASTER VDC: (FLYWHEEL ONLY) RUNTIME IN SECONDS

VDC-XE 300 kW		MHF 100	MHF 120	MHF 160	MHF 200	MHF 250	MHF 300	MHF 400	MHF 500	MHF 600
<b>Number of FLYWHEELS</b>	<b>POWER</b>	<b>100</b>	<b>120</b>	<b>160</b>	<b>200</b>	<b>250</b>	<b>300</b>	<b>400</b>	<b>500</b>	<b>600</b>
1	100%	40	33	22	15	9	5	-	-	-
2		79	65	49	39	30	24	14	8	-
3		118	98	73	58	46	38	28	20	14
4		156	129	97	77	61	51	38	30	23
5		195	162	121	97	77	60	48	38	31
<b>Number of FLYWHEELS</b>	<b>POWER</b>	<b>100</b>	<b>120</b>	<b>160</b>	<b>200</b>	<b>250</b>	<b>300</b>	<b>400</b>	<b>500</b>	<b>600</b>
1	75%	54	45	33	25	17	11	5	-	-
2		106	88	65	52	41	34	24	16	10
3		157	131	98	78	62	51	38	30	23
4		208	173	129	103	82	68	51	40	33
5		260	217	162	129	103	86	64	51	42
<b>Number of FLYWHEELS</b>	<b>POWER</b>	<b>100</b>	<b>120</b>	<b>160</b>	<b>200</b>	<b>250</b>	<b>300</b>	<b>400</b>	<b>500</b>	<b>600</b>
1	50%	82	68	51	40	32	25	11	5	4
2		159	132	99	79	63	52	39	30	23
3		237	197	147	118	94	78	58	46	38
4		313	260	195	156	124	103	77	61	51
5		391	326	244	195	156	129	97	77	64
<b>Number of FLYWHEELS</b>	<b>POWER</b>	<b>100</b>	<b>120</b>	<b>160</b>	<b>200</b>	<b>250</b>	<b>300</b>	<b>400</b>	<b>500</b>	<b>600</b>
1	25%	160	135	101	80	64	53	39	26	23
2		313	260	195	156	124	103	77	61	50
3		465	387	290	232	185	154	115	92	76
4		614	511	383	306	245	204	152	122	101
5		767	639	479	383	306	255	191	152	126

All runtimes refer to UPS with 0.9 pf and 94% efficiency for 100%, 75% and 50% load, and 92% efficiency for 25% load. With no battery connected.





## **Software and accessories**

# Software

## PowerShield<sup>3</sup>

### SHUTDOWN SOFTWARE

ORACLE SOLARIS CITRIX redhat ubuntu debian



### HIGHLIGHTS

#### GRAPHIC MONITORING OF UPS AND ENVIRONMENTAL SENSOR STATUS

PowerShield<sup>3</sup> is a simple but powerful UPS management tool. A graphic version is available for all operating systems.

#### DETAILED DISPLAY OF ALL UPS AND ENVIRONMENTAL SENSOR PARAMETERS

PowerShield<sup>3</sup> provides all the information required for first level diagnostics.

#### EVENTS LOG AND GRAPHIC DISPLAY OF MAIN PARAMETERS

All changes in UPS operating states are logged, as well as the main physical values and parameters. These constantly recorded values are displayed in graphic format.

#### UPS CONTROL PROGRAMMING

This allows you to automate all the actions normally carried out by the user: turning the server on and off, UPS battery test, etc.

#### BLOCK DIAGRAM OF OPERATION

A display of UPS operation in the form of a block diagram makes the analysis of UPS operating states more intuitive.

PowerShield<sup>3</sup> provides efficient, user-friendly UPS management, displaying all major operational information such as input voltage, applied load and battery charge. The software also provides detailed information on fault conditions and UPS operating states. Developed with a client/server architecture, it is the ideal tool for managing multi-platform network systems.

### Features

- **PowerShield<sup>3</sup> free version:** supports a single UPS for the operating systems highlighted in **green**.
- **PowerShield<sup>3</sup> full version:** supports up to maximum of 32 UPS for all operating systems.
- With sequential and priority-based shutdown, PowerShield<sup>3</sup> provides unattended shut-down of all networked PCs, saving any active work on the most widely used applications. Users can define the shutdown priorities for the various

computers in the network and can also customise the procedure.

- With multi-platform compatibility, PowerShield<sup>3</sup> uses the TCP/IP communications protocol to achieve standardised management and monitoring across the widest possible range of platforms. This makes it possible to monitor computers with different operating systems from a single console, for example monitoring a UNIX server from a PC running Windows and also connecting to UPS located in different geographical areas using dedicated networks (intranets) or the Internet.
- With event scheduling, PowerShield<sup>3</sup> users can program their own shutdown procedures, detailing power-off and power-up scenarios to increase system security and save energy.
- With messages management, PowerShield<sup>3</sup> keeps users constantly informed about the status of UPS and environmental sensors, either locally or via network messages. A list can also be defined of users who should receive e-mails, faxes, voice messages and SMS messages when faults or sudden mains power supply failures occur.
- Integrated SNMP agent: PowerShield<sup>3</sup> features an integrated SNMP agent for UPS management which can send all the information required and generate traps using the RFC1628 standard, and environmental sensors.
- Secure, easy to use and connect; communication is now password protected to ensure UPS system security. Using the new discovery/ browsing function, all UPS connected to a protected computer

and/or LAN can be displayed in a list format for monitoring. In the absence of a LAN connection, support is provided for modem-based communication.

### Developed for virtualized systems

PowerShield<sup>3</sup> permits to initiate live migration of virtual machines (VM) to automatically and transparently migrate VMs during power disturbance to protected devices by UPS with migration systems such as VMware vMotion™ and Microsoft Live Migration. PowerShield<sup>3</sup> can monitor and manage UPS either inside or outside the data centre. Can also measure power consumption to help calculate power usage effectiveness (PUE), a the standard metric utilized for gauging data centre power efficiency.

### Supported operating systems

- Windows 2008, 2012, 2016 Server, XP, Vista, 7, 8, 10 on X86, X86\_64 and IA 64 processors
- Microsoft Hyper-V
- Microsoft SCVMM™
- Linux on X86, X86\_64 and IA64 processors
- Novell Netware 3.x, 4.x, 5.x, 6
- Mac OS X
- VMWare ESX, ESXi.
- Citrix@ XenServer,
- Xen@ open source platforms
- The most common UNIX operating systems such as: IBM AIX, HP, SUN Solaris INTEL and SPARC, SCO Unixware and Open Server, Silicon Graphics IRIX, Compaq Tru64 UNIX and DEC UNIX, Open BSD UNIX and FreeBSD UNIX, NCR UNIX
- HP OPEN VMS.



PowerShield<sup>3</sup> is available for download at [www.riello-ups.com](http://www.riello-ups.com)



# PowerNetGuard

## INVENTORY MANAGER SOFTWARE



### HIGHLIGHTS

#### GRAPHIC MONITORING OF UPS AND ENVIRONMENTAL SENSOR STATUS

PowerNetGuard is a simple but powerful UPS management and display tool. A graphic version is available for all operating systems.

#### DETAILED DISPLAY OF ALL UPS AND ENVIRONMENTAL SENSOR PARAMETERS

PowerNetGuard provides all the information required for first level diagnostics.

#### EVENTS LOG AND GRAPHIC DISPLAY OF MAIN PARAMETERS

All changes in UPS operating states are logged, as well as the main physical values and parameters. These constantly recorded values are displayed in graphic format.

#### CENTRALISED MANAGEMENT

PowerNetGuard is the ideal solution for managing all UPS in an infrastructure using a single application. With this one application you can monitor and manage all your UPS, ensuring prompt warnings in the event of faults or malfunctions.

#### SUPPORT FOR THIRD PARTY UPS

PowerNetGuard also allows you to manage UPS made by other manufacturers via SNMP using their own network boards. This allows you to centralise the management of the UPS fleet into a single system without the need for many different applications, simplifying management and use.



PowerNetGuard is available for download at [www.riello-ups.com](http://www.riello-ups.com)

PowerNetGuard software centralises UPS management using network interface (SNMP) communications. It is ideal for Data Centre EDP managers and medium to large-sized networks. Using the RFC1628 Management Information Base (MIB), it ensures standardised management for all UPS compliant with this worldwide standard.

### Features

- Centralised control of remote UPS via Ethernet with SNMP protocol
- Multi-level display of geographical areas, building plans, maps, etc.

- Multi-user access with various security levels
- Compatible with NetMan and RFC1628 standard SNMP agents
- Creation of graphs of input and output values and data back-up to file
- Alarm notifications via e-mail and SMS
- Windows operating systems 10, 8, 7, 2016, 2012 and previous versions, Mac OS X, Linux.

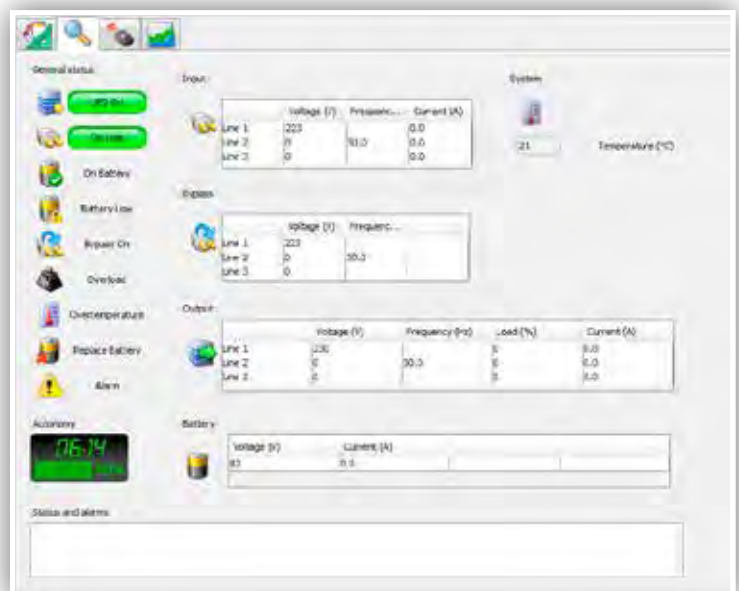

# Accessories

## NetMan 204

CARD - ETHERNET - SNMP



The NetMan 204 network agent allows UPS directly connected over LAN 10/100 Mb connections to be managed using the main network communication protocols (TCP/IP, HTTP and SNMP). It is the ideal solution for the integration of UPS over Ethernet networks with MODBUS/TCP or BACNET/IP protocols. It was developed to integrate UPS into medium-sized and large networks, to provide a high level of reliability in communication between the UPS and associated management systems.

### Features

- 32 bit RISC processor
- Compatible with 10/100 Mbps Ethernet and IPv4/6 networks
- wifi ready
- Compatible with PowerShield<sup>3</sup> and TeleNetGuard
- SNMP v1 and v3 with RFC1628 for PowerNetGuard and NMS connection
- SNMP v1, v2 and v3 with RFC3433 for the management of environmental sensors
- HTTP for UPS control via web browser
- SMTP for alarm notifications and UPS status updates via email
- MODBUS/TCP
- BACNET/IP
- Maximum expandability
- USB host for Pendrive USB connection
- Events log and data management
- Wake-on-LAN management for starting computers via TCP/IP network
- Other standards: DHCP, DNS, RARP, FTP, NTP, ICMP, IGMP
- Management of environmental sensors
- Configurable via Telnet or SSH sessions, and web
- Firmware upgradeable via USB port, FTP and HTTP.



## Environmental sensors

FOR NETMAN 204

The NetMan 204 environmental sensors are able monitor and record environmental conditions as well as activities in protected areas and the area where the UPS is installed. The environmental sensors allow management and control to be extended to cover the area around the UPS, monitoring the temperature and humidity and driving cooling fans or locks. Values are provided via Internet, SNMP and via PowerShield<sup>3</sup> software. PowerShield<sup>3</sup> can be used to manage sensor operating states in order to send messages. Refer to PowerShield<sup>3</sup> software documentation for further information. NetMan 204 can manage up to 6 separate sensors. Environmental sensors are quick

to install thanks to their small footprint, and they do not require a separate external power supply. Thanks to the self-learning sensors, configuration is also rapid and intuitive.



### The following sensors are available:

- -55 +125 °C Temperature Sensor
- -55 +125 °C Temperature and 0-100% humidity Sensor
- -55 +125 °C Temperature and I/O digital 0-12 Vdc In, 1 A max Out at 48 Vdc Sensor.

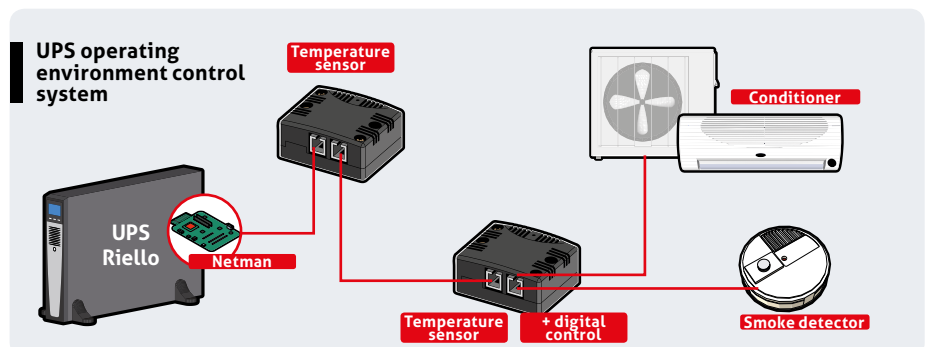
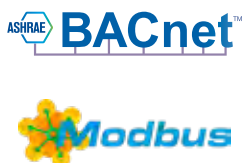

# MultiCOM 302

## CARD - MODBUS/JBUS INTERFACE

The MultiCOM 302 protocol converter allows UPS monitoring using the MODBUS/JBUS protocol over RS232 or RS485 serial lines. In addition, it also manages a second independent RS232 serial line that can be used to connect to other devices such as the PLC or a PC running PowerShield<sup>3</sup> software.

### Features

- Port configuration for MODBUS/JBUS as RS232 or RS485
- Management of two independent serial lines
- Suitable for integration with the main BMS management programs.



# MultiCOM 352

## CARD - INTERFACE DUPLEXER

The MultiCOM 352 serial duplicator is an accessory that allows two devices to be connected to a single communication serial port on the UPS. It can be used anywhere where several serial connections are required for multiple polling of the UPS. It is ideal for LAN networks with firewalls, where a high level of security is required, or for the management of separate LAN networks supplied by a single UPS.

### Features

- Cascading configuration giving a maximum of 4 serial communication ports
- LED communication flow indicator
- Firmware upgradeable via serial port.



# MultiCOM 372

## CARD - RS232 INTERFACE

The MultiCOM 372 allows an additional communication port to be added to the UPS to control and monitor the UPS via the RS232 serial line. The board is supplied with an ESD (UPS Emergency Shutdown) input and an RSD (Remote Shutdown) input, both available on a removable terminal board and directly connectible to emergency buttons or other buttons.

### Features

- Management of ESD input and UPS Shutdown
- Ability to supply devices at 12 V 80 mA max.

*For compatibility, refer to the Table on page 18*



# MultiCOM 384

## CARD - RELAY I/O INTERFACE

The MultiCOM 384 provides a set of relay contacts for managing UPS alarm notifications and operating states. The board has two removable terminal boards. One of these terminal boards includes the ESD (UPS Emergency Shut Down) and RSD (Remote Shut Down) signals. The board also provides the possibility of associating Battery Working, Bypass, Alarm and Battery Low warnings with potential

free contacts on normally close or normally open contacts.

### Features

- Max. current 3 A at 250 Vac
  - Signal-contact customisation
  - Normally Open or Normally Close configuration for each contact
- For compatibility, refer to the Table on page 18*



# Multi I/O

## BOX - RELAY I/O CARD & MODBUS/JBUS INTERFACE

The Multi I/O is a device that integrates UPS into a control system using fully configurable input and output relay signals. It can be used to connect two devices to a single UPS serial communication port. It can be used anywhere where several serial connections are required for multiple polling of the UPS. It can also communicate on RS485 lines using the MODBUS/JBUS protocol.

### Features

- 8 analogue/digital inputs
- 8 relay outputs (3A at 250Vac) that can be configured using UPS and input operating states
- Can communicate with UPS via RS232
- It can control two independent RS232/RS485 serial lines to monitor the UPS and its operating states using the MODBUS/JBUS protocol
- Firmware upgradeable via serial port.



# I/O

## EXPANSION BOARD

The I/O expansion board for the Master range is equipped with:

- 6 outputs with NC/NO potential-free contacts (250 V/5 A), electrically isolated from each other and from other circuits
- 2 self-powered inputs.

Each output or input can be configured with different meanings, using the associated menu.

*For compatibility, refer to the Table on page 18*

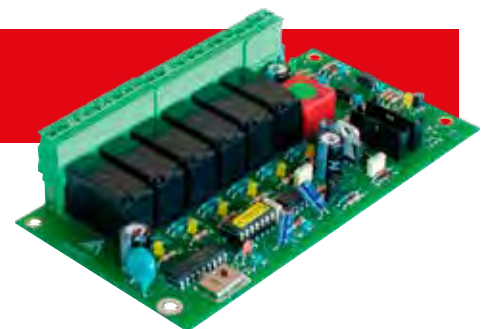



# Multi Panel

## REMOTE DISPLAY INTERFACE

The Multi Panel is a remote monitoring device that can provide a detailed UPS status overview in real time. This device is able to display mains power, output and battery readings as well as UPS operating states. The high visibility graphic display supports English, Italian, German, French, Spanish, Russian, Chinese and many other languages. It has 3 independent serial ports, one of which allows for UPS monitoring via the MODBUS/JBUS protocol (on either an RS485 or RS232 serial line). The other independent serial lines can be used to connect devices such as the Netman 204 or a PC running PowerShield<sup>3</sup> software.

### Features

- High visibility LCD with graphic functions
- Management of three independent serial lines
- Port configuration for MODBUS/JBUS as RS232 or RS485
- Suitable for integration with the main BMS management programs
- Firmware upgradeable via serial port.



# Multi Pass 10, 16, and 16-R

## MAINTENANCE BYPASS

The Multi Pass manual bypass cuts out UPS in the event of malfunction or breakage. Multi Pass ensures that the connected consumers are automatically switched to mains power if a UPS is switched off or goes into blocked status. Multi Pass is available for rack or wall installations (box).

### Features

- 16 A rack version
- 10 A and 16 A wall version
- Standard back-feed protection
- Automatic switching during mains failure
- Mains power present LED indicator
- Available with different socket standards (IEC, British socket, terminal boards).



# MBB32A

## MAINTENANCE BYPASS

Available in a 32 A single-phase configuration, enables UPS servicing Sentinel Dual from 5 to 6 kVA in a quick and safe manner ensuring power continuity. Equipped with a metal bracket for wall mounting.



# MBB125A 4P, MBB100A 2P

## MAINTENANCE BYPASS

Available in a single configuration that allows for manual bypass operations on any single-phase UPS from 10-20 kVA and three-phase UPS from 10-60 kVA. The device is equipped with three disconnect switches for the complete isolation of the UPS in the event of maintenance or removal, whilst guaranteeing power supply continuity to the consumers. The device is equipped with a manual

bypass closure warning micro-switch to be connected to the dedicated input on the UPS in order to prevent simultaneous supply from the manual bypass and inverter.

**RIELLO UPS offers a wide range of external bypasses and static switches for UPS up to 800 kVA, and for parallel systems up to 6.4 MVA.**



MBB125A 4P



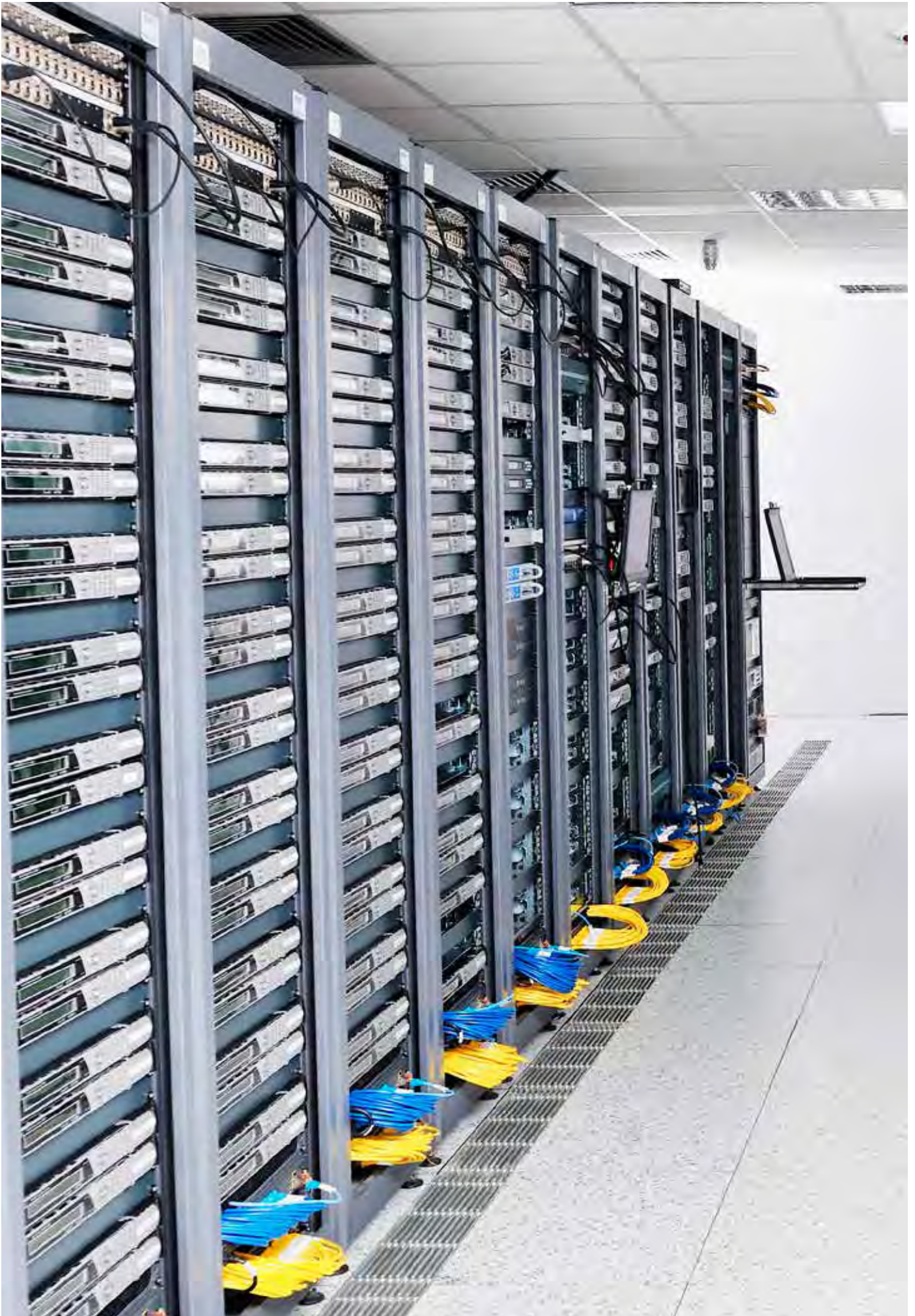









# Connectivity

# Connectivity

## Index of configurations

Connecting a UPS to other devices, sensors, computers and other specific devices, means on the one hand allowing the user to monitor UPS operating parameters and prevent critical situations, and on the

other hand provides the UPS with input parameters from the working environment. By processing these parameters the UPS is able to activate/deactivate itself, communicate its status and much more.

This brief overview summarises some of the basic connectivity configurations, grouped according to the end purpose and situation surrounding each case.

- Point to point connections
- Multipoint connection
- Connection for UPS in parallel setup
- Connection with several systems in parallel setup and STS

- Field bus connections
- Bus connections over Ethernet
- Field bus connections
- Serial bus connections

### POINT TO POINT CONNECTIONS

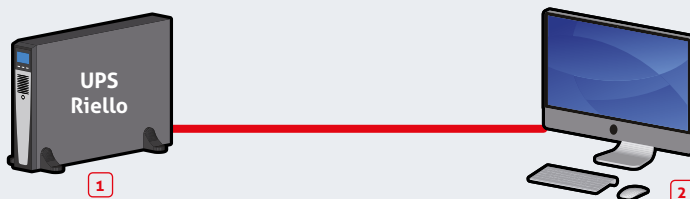

Controlling the UPS from 1 workstation

- 1 UPS connected to load
- 2 Local computer with PowerShield<sup>3</sup> version FREE

— USB or RS232

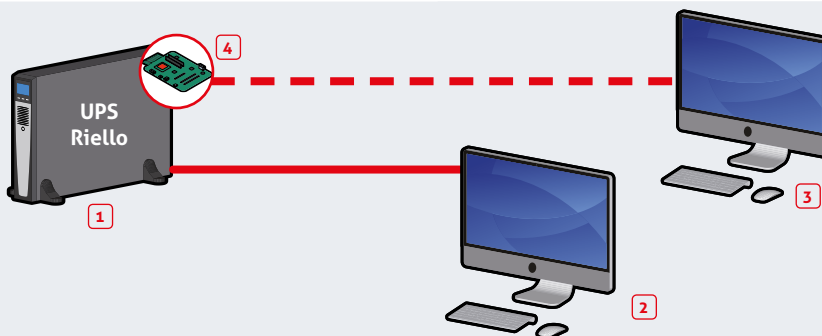

Controlling the UPS from different workstations

- 1 UPS connected to load
- 2 Local computer with PowerShield<sup>3</sup> version FREE
- 3 Local computer with PowerShield<sup>3</sup> software version FULL
- 4 MultiCOM 372 board

--- RS232

— USB or RS232

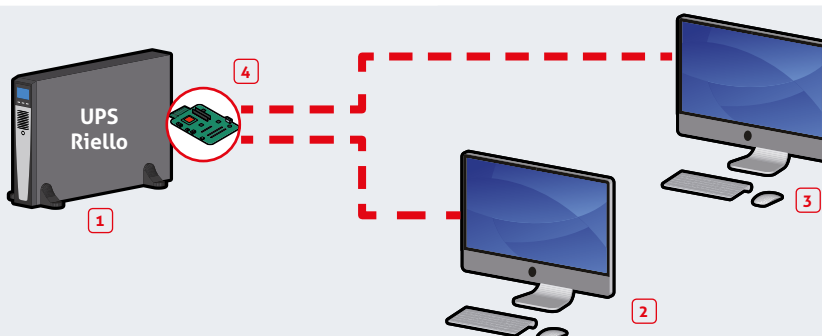

UPS control from several workstations, using 2 serial ports

- 1 UPS connected to load
- 2 Local computer with PowerShield<sup>3</sup> version FREE
- 3 Local computer with PowerShield<sup>3</sup> version FREE
- 4 MultiCOM 352 board

--- RS232

## DISTRIBUTED CONNECTION (MULTIPOINT)

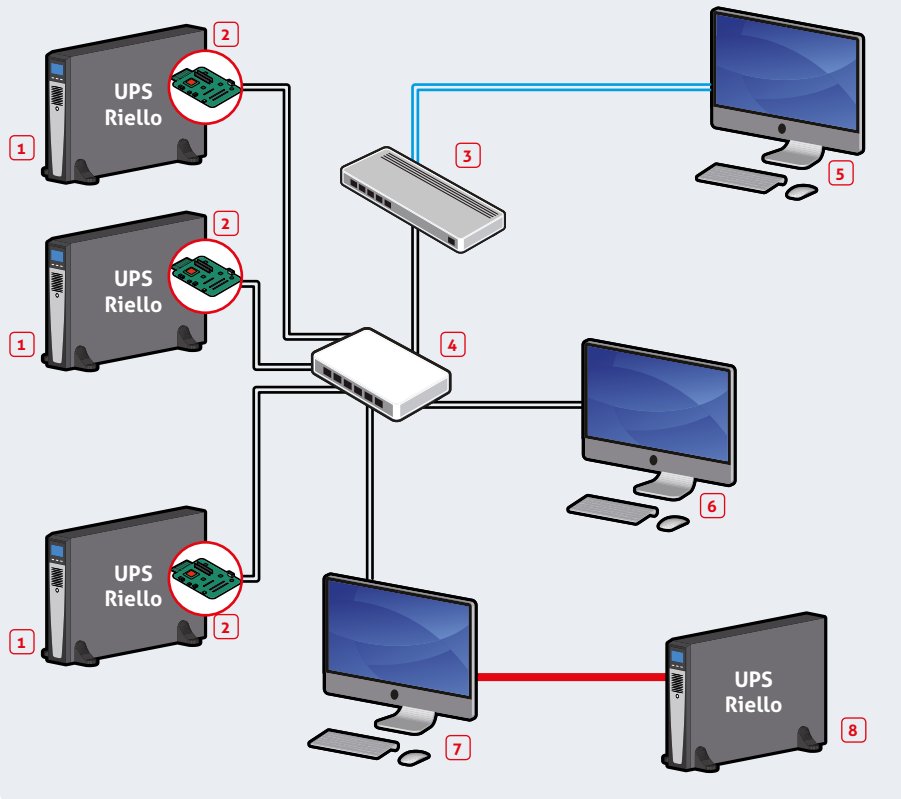

Connection with more than 1 UPS.  
The FULL version of PowerShield<sup>3</sup> software is required as well as a NetMan 204 communication board on each UPS.

- 1 UPS connected to load
  - 2 NetMan 204 board
  - 3 Firewall
  - 4 Switch
  - 5 Remote computer connected via web
  - 6 Local computer
  - 7 Local computer that controls the UPS (8) via USB or RS232, and UPS (1) via LAN and Ethernet
  - 8 UPS connected to load
- USB or RS232  
 Ethernet  
 World Wide Web

## CONNECTION FOR UPS IN PARALLEL SETUP

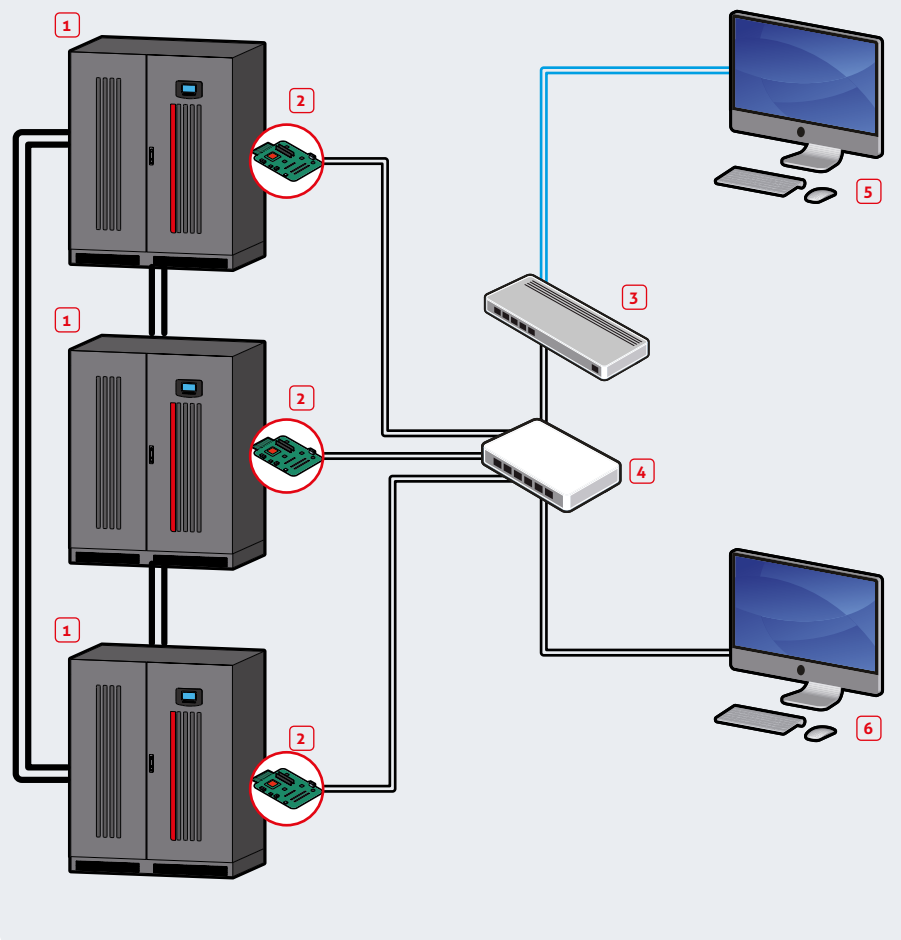

The FULL version of PowerShield<sup>3</sup> software should be used for managing setups with several UPS installed in parallel, and each UPS must have a NetMan 204 board installed.

- 1 UPS in parallel setup connected to the load
  - 2 NetMan 204 board
  - 3 Firewall
  - 4 Switch
  - 5 Remote computer connected via web
  - 6 Local computer
- Parallel setup bus  
 Ethernet  
 World Wide Web

## CONNECTION WITH SEVERAL SYSTEMS IN PARALLEL AND STS

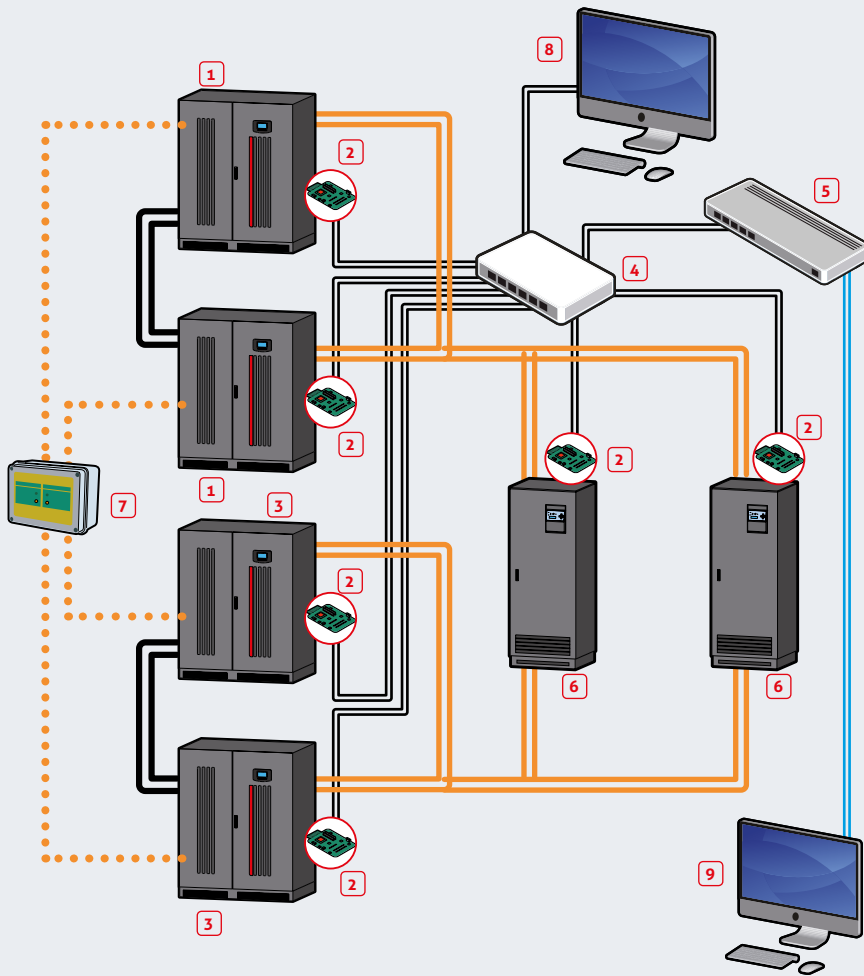

The FULL version of PowerShield<sup>3</sup> software should be used for managing setups with several UPS installed in parallel, and each UPS must have a NetMan 204 board installed.

- 1 UPS arranged in parallel connected to an STS channel
- 2 NetMan 204 board
- 3 UPS arranged in parallel connected to an STS channel
- 4 Switch
- 5 Firewall
- 6 STS connected to load
- 7 UGS
- 8 Local computer with PowerShield<sup>3</sup> software version FULL
- 9 Remote computer connected via web, running PowerShield<sup>3</sup> software version FULL

●●●● UGS management of parallel setup

●●●● Parallel setup bus

— Ethernet

— World Wide Web

— Parallel setup bus

— Power connection

## FIELD BUS CONNECTION OVER ETHERNET

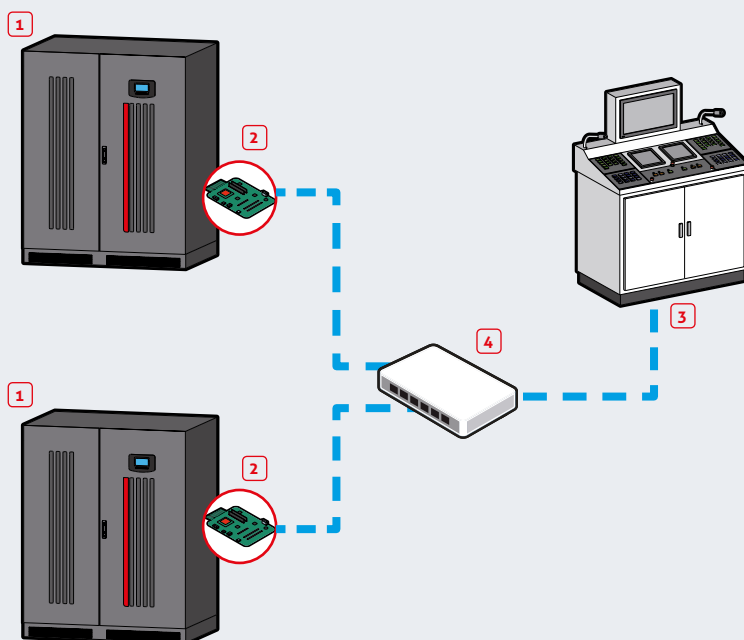

For UPS management in industrial or civil environments requiring Modbus protocol communication over Ethernet.

- 1 UPS connected to load
- 2 NetMan 204 board
- 3 SCADA management system
- 4 Switch

— Ethernet

— Modbus / TCP over Ethernet



## MODBUS SERIAL FIELD BUS CONNECTION

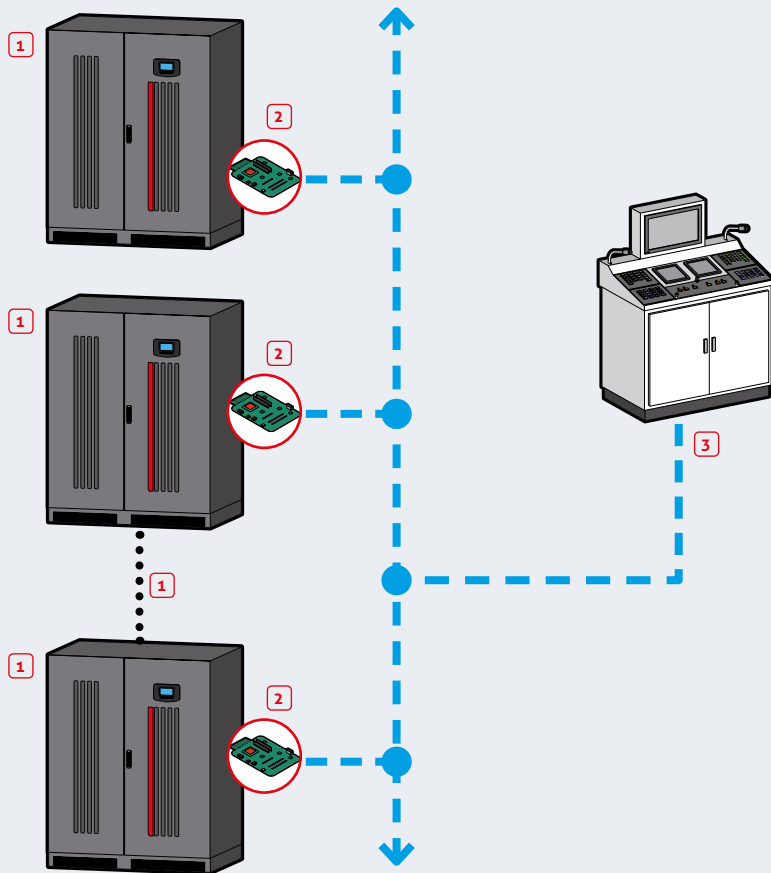

For UPS management in industrial or civil environments requiring Modbus protocol communication over RS485 line.

- 1 UPS connected to load
- 2 MultiCOM 302 board
- 3 SCADA management system

— Ethernet  
 - - - Modbus RS485

## POWERSHIELD<sup>3</sup> ON VIRTUALIZED SYSTEMS: WMWARE ESX; MICROSOFT HYPER-V; CITRIX

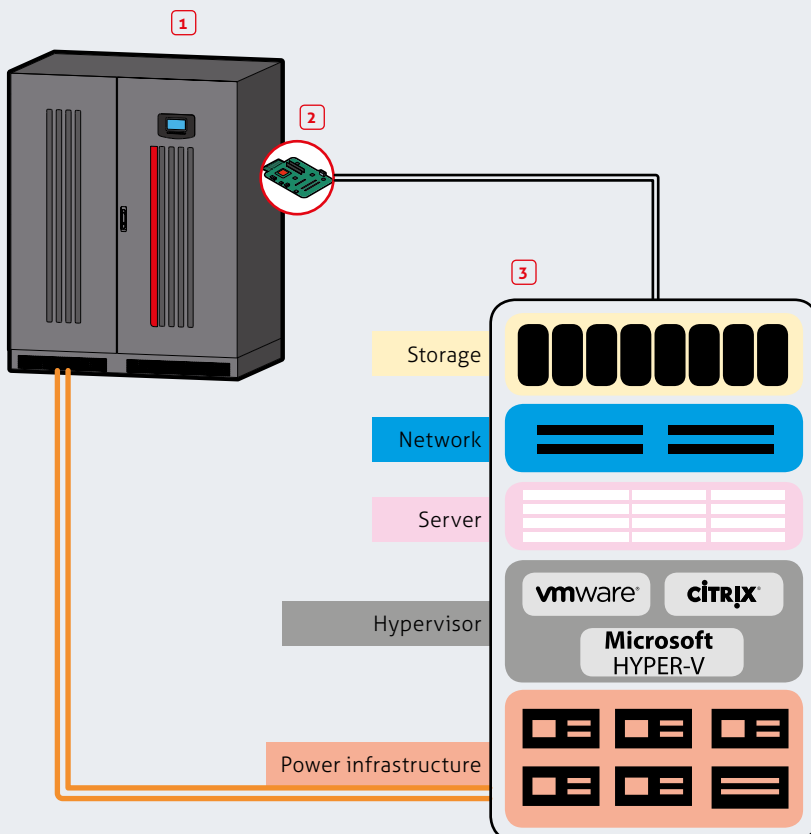

PowerShield<sup>3</sup> software should be used for managing setup with UPS, a specific script to shut down the virtualized system must be used, UPS must have a NetMan 204 board installed.

- 1 UPS
- 2 NetMan 204
- 3 Virtualized system

— Ethernet  
 — Power connection





## Technical pages

# POWER PROBLEMS

## Why an Uninterruptible Power Supply?

Data centres, servers, LAN nodes and telecommunication systems must always be protected against possible problems with power supply. Sudden blackouts and variations in the mains supply may lead to system malfunctions and severe data losses. But even other types of electrical equipment can be damaged or in turn cause damage or inconvenience if there is a fault in the mains supply.

You only need to think about the check-outs in supermarkets, lighting systems and industrial production units, not to mention safety systems, medical equipment, pumping installations and automatic devices in general.

The simplest and most effective way of coping with these disturbances in the electricity network is to install a UPS unit (UPS stands for Uninterruptible Power Supply). Acting as an interface between the mains and the loads, a UPS guarantees the continuity and the quality of the electricity supplied to the loads, regardless of the condition of the mains.

In fact these machines stabilise the voltage perfectly, eliminating all disturbances and when the mains supply fails, they even supply voltage via a series of batteries which provide power long enough to guarantee the safety of persons and the system. In order to select the type of appliance that is best suited to ensure the required level of protection, you need to be aware of the types of problems with the mains supply that may disturb your appliances.

Most blackouts are caused by incorrect operations during plant maintenance operations or, more trivially, due to improper use of equipment leading to overloads or short circuits.

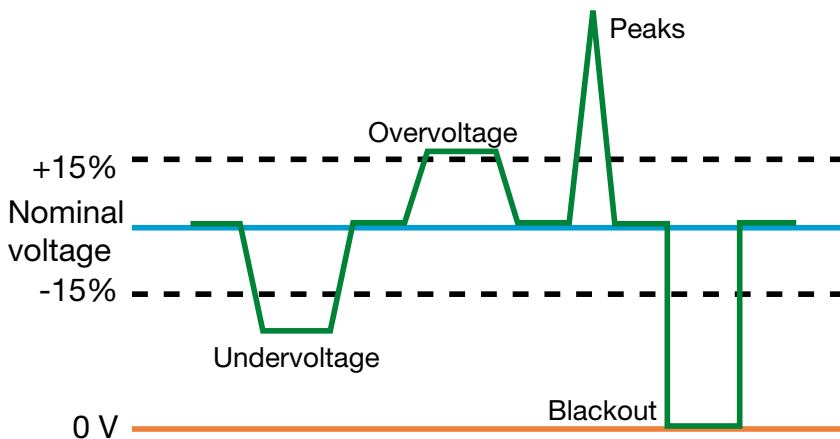
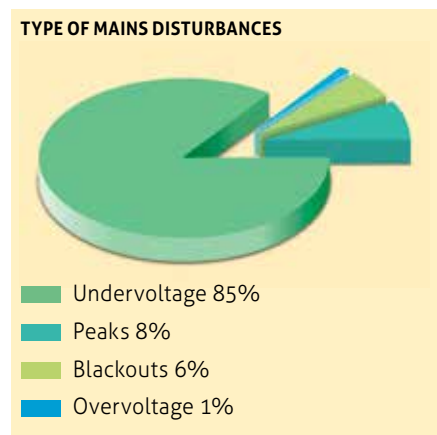
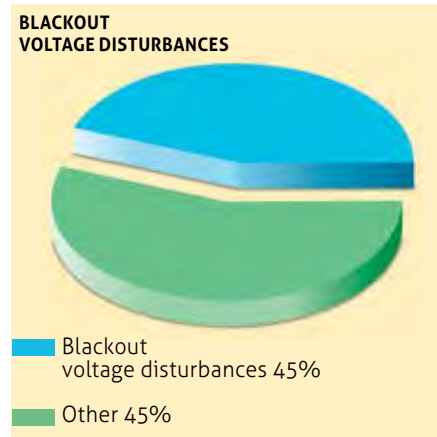

## Reference technical standards

### Safety

*EN 62040-1-1* is the reference standard regulating the basic safety requirements for UPSs used in areas accessible to operators. *EN 62040-1-2* is the reference standard regulating UPS used in restricted access locations (control panels, electricity cabinets etc.).

### Electromagnetic compatibility

UPSs are designed to operate in situations where disturbances can occur but, at the same time, to emit the lowest possible number of disturbances so as not to cause inconvenience with other appliances in the system. The immunity and emission limits as well as the test methods are defined in the IEC *EN 62040-2* standard.

### Performance

The reference document is "Method of specifying the performance and test requirements" *EN 62040-3*; this standard is a guide to achieving better understanding between manufacturers and users, as it defines the performance levels that must be declared and the test methods for this. All UPS Riello UPS are designed and constructed in compliance with the above standards and thus they bear the CE marking .

**CEI, CENELEC and IEC are the recognized standardization bodies respectively at Italian, European and international level. The following internationally-recognized European standards on UPS, ensure compliance with EC Directives.**



# TYPES OF UPS

Classification of UPS according to the CEI EN 62040-3 standard (method of specifying performance and test requirements).

## Off-line (VFD)

In normal operating mode, the load is powered directly from the mains through the UPS static switch.

When the mains voltage is not within the UPS preset tolerances, the load is transferred to the inverter in about 2-4 ms using battery power. The voltage generated by the inverter is typically step-wave or square-wave.

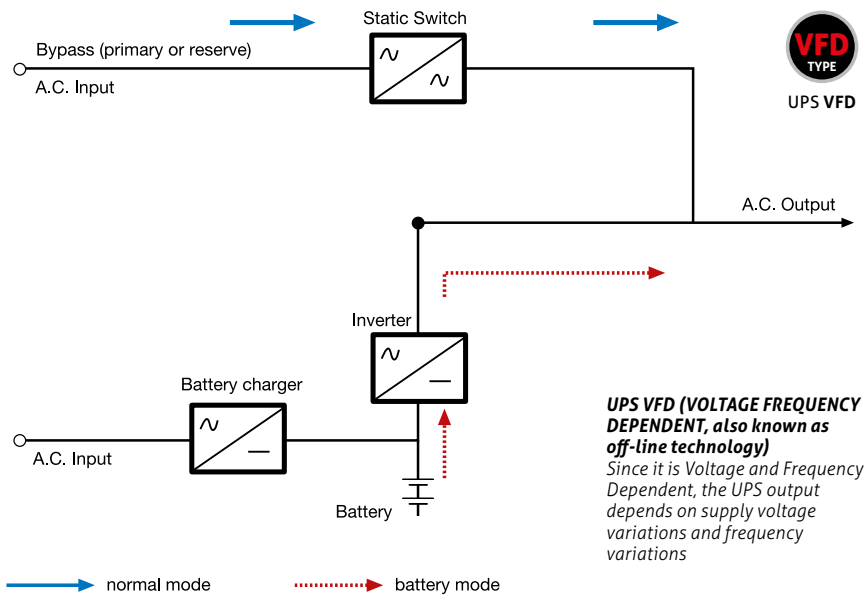

## Line Interactive (VI)

In normal operating mode, the load is powered from the mains through an AVR (Auto Voltage Regulator) circuit.

This device corrects voltage variations within its capacity for regulation, returning the voltage to its default values. When the variations in the power supply are not within the capacity for regulation of the AVR circuit, the inverter intervenes and through the stored energy in its batteries it ensures the continuity and quality of the power supply. The transition from stabilised mains to inverter supply takes place in about 2-4 ms and the voltage generated by the inverter can be of a sinusoidal type or step-wave (square-wave) type depending on the UPS model.

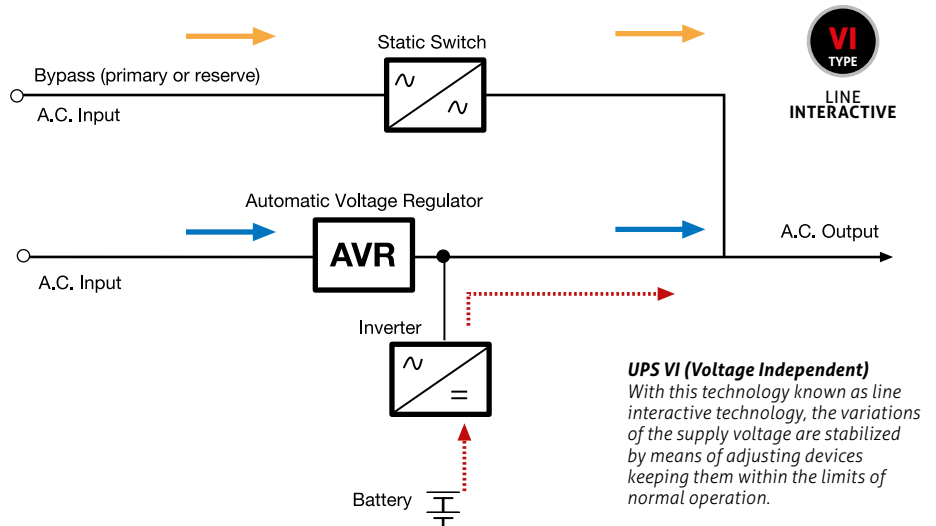

## Double Conversion (VFI)

In normal operating mode, the load is powered by the combination of rectifier/inverter.

When the AC input supply is not within the voltage and frequency tolerances, the unit enters into battery mode operation where the battery/inverter combination continues to power the load for as long as its power lasts, or until the AC input power returns within the required tolerances. The intervention time for battery operation is instantaneous (0 ms).

If the rectifier/inverter fails or in the event of an overload, either in the permanent or transition mode, the unit goes into bypass mode (0 ms), where the load is temporarily supplied via the reserve line.

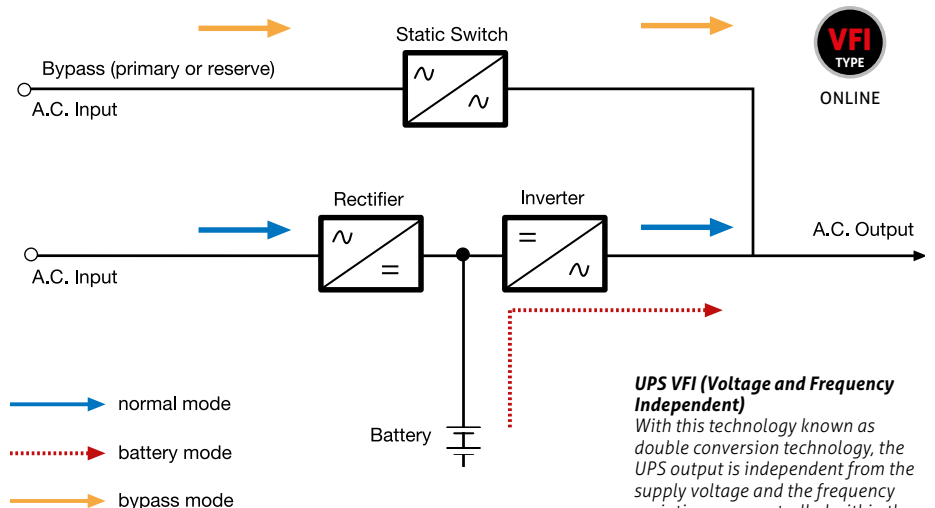

# EVALUATION PARAMETERS

## Apparent power (in VA or kVA)

It is defined as:

$$VA = V \times I$$

for single-phase load

$$VA = V \times I \times \sqrt{3}$$

for three-phase load

where **V** is the load voltage supply and **I** is the current absorbed by the load in normal load conditions. This information is normally shown on documents and/or load nameplates though it is often shown as an oversized value.

## Active Power in W or kW

It is defined as:

### Watt: VA x Pf

(the PF sometimes is identified with the **COSφ**)

The PF or the **COSφ** is rarely indicated so the correct sizing requires you to know the active power (W) of the loads.

However the experience shows that the new IT system loads, such as the computer servers, typically have the power factor 0.9 or greater while the personal computers have the Pf 0.60 - 0.75.

## Crest factor

A linear load absorbs a sinusoidal current that has an effective value (**IEFF** usually measured and declared) and a peak value (**IPK**).

The Crest Factor value is defined as:

$$CF = \frac{IPK}{IEFF}$$

The normal value for a linear load is CF = 1.41. Most loads applied to UPS are non-linear loads; they absorb distorted currents that have a CF greater than 1.41 and therefore require higher peak currents resulting in increased distortion of the output compared to equivalent linear loads. The EN62040-1 Standard defines a typical non-linear load with CF = 3, used for testing UPS that can be used in the absence of other data.

## Overload

Overloads are temporary requests from users that exceed absorption in continuous operation. They are caused by current peaks which may occur when one or more appliances are switched on.

If the overload exceeds the admissible limits, the UPS guarantees the energy supply via the automatic bypass line. In the event of an "On line" UPS, the transfer is effected without any break in power (transfer time = 0 ms).

The by-pass is a safety device with protection and its own auxiliary power supply and therefore it supplies the load with its own circuit that is independent from the rest of the UPS.

## Input current harmonics

The rectifier/battery-charger in the UPS absorbs a distorted current from the mains, containing multiple harmonics compared to the fundamental frequency of 50 Hz. When these harmonics are returned to the mains upstream, they can lead to a distortion in voltage that, if high, can affect the normal operation of the non-privileged users. The harmonic input values of Riello UPS are set at a level that meets with current regulations.

To reduce them further, the Riello UPS use rectifiers with PFC (Power Factor Control) or IGBT that absorb current from the mains by generating a low harmonic content. Another solution is to use resonant filters at the input which provide a local way for the harmonics to circulate and that therefore should not affect the mains in a significant way. The filters are available as accessories.

## Runtime

The batteries supplied with the UPS are valve-regulated batteries (VRLA) better known as sealed batteries with immobilized electrolyte and very low gas loss and which, therefore, can be installed in public places and offices without special precautions. Normally batteries are supplied together with the UPS and may be kept in the same cabinet or in additional cabinets with an isolation switch.

# MAINS DISTURBANCES

## Undervoltage

An undervoltage is a reduction in the amplitude of the voltage for a time ranging from 10 ms to 1 s. The voltage variation is expressed as a percentage of the nominal voltage between 10 and 100%. A voltage drop of 100% is called an opening or is normally known as blackout. Micro-interruptions or micro-openings, can be induced by transient faults (between 10ms and 1s).

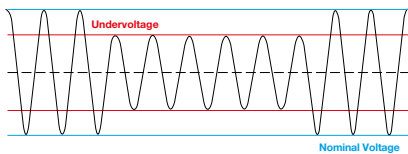

Short openings can be induced, on the other hand, by the operation of protection devices (1 s to 1 min.). Long openings are usually induced by problems that occur on the high-voltage grid ( $\geq$  to 1 min).



## Consequences:

- **Computer Applications:** system blackouts with corruption or loss of data, overheating and ageing of electronic components resulting in operational paralysis.

- **Industrial applications:** Instability of asynchronous motors and loss of synchronization of synchronous motors, opening of contactors (undervoltage > 30%), power-off of discharge lamps with undervoltage > 50% for 20-40 ms, with subsequent return of power that only occurs after several minutes, resulting in operational paralysis.

## Overvoltages

An overvoltage is an increase in voltage for a time of over 10 ms. Overvoltages can be induced by the disconnection of heavy loads (interruption of production processes in industries: the reduction in speed of electric motors, arc furnaces, rolling mills etc.) or by natural events such as lightning.

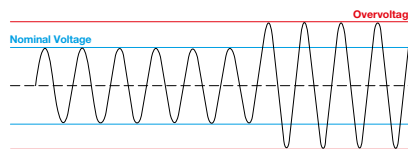

## Consequences:

- Faults with all electrical/electronic equipment (100% < overvoltage < 150%): e.g. damage to circuit boards, power packs, computers/servers, faults with lighting systems etc.

## Flicker effect

The flicker effect is a flickering of lights induced by rapid variations in voltage. These voltage variations are caused by loads in which the power absorption varies very quickly: arc furnaces, welding machines, rolling machines, laser cutters.

## Consequences:

the flickering of lights is very unpleasant for those who witness it.

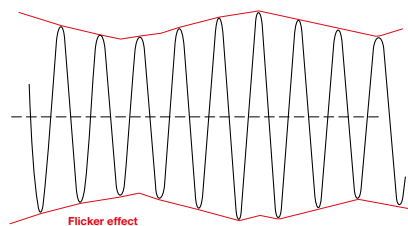

## Transient effect

Transient phenomena consist of very high and fast overvoltages that reach as much as 20 kV. These transients are caused mainly by lightning (random phenomenon according to location, duration and amplitude) but also by manoeuvres or faults on the high voltage grid, by inductive load switching or by the powering of highly capacitive loads.

## Consequences:

Transients destroy inadequately protected equipment (melting of wires, perforation of insulation in motors, badly-timed releases of protection devices, etc.).

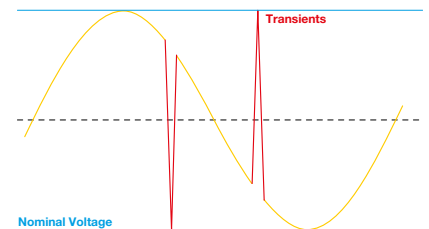

# HARMONICS

## Definition of harmonics

Given a sinusoidal (fundamental) magnitude, one can define as harmonic a sinusoidal multiple frequency magnitude. The order of the harmonic is the relationship between its frequency and that of the fundamental: for example, if the fundamental is 50 Hz, the third-order harmonic, or third harmonic has a frequency of 150 Hz. The sum of the fundamental and the harmonics gives rise to a function that is periodic but not sinusoidal (distorted waveform). A distorted waveform is therefore equivalent to a presence of harmonics, and vice versa. In general, any periodic function can be broken down into a series of sinusoidal functions (Fourier series).

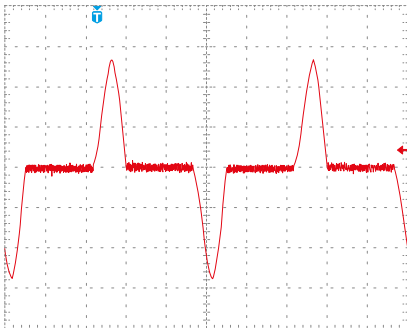
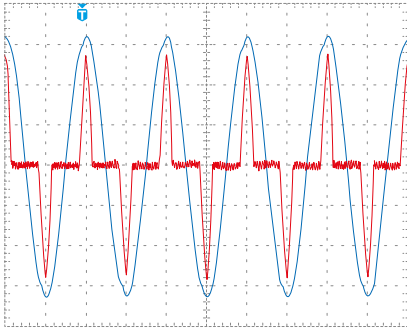

## Origin of harmonics

Devices that generate harmonics are present in the industrial sector, the service sector and also in the home. Harmonics are generated by non-linear loads: a load is defined as non-linear when the current which it absorbs does not have the same form as the voltage that supplies it. Power electronics such as rectifiers, inverters, electronic starters, variable frequency motor drives, switching power supplies, discharge lamps are classic examples of non-linear loads. The powering of non-linear loads causes the appearance of THDIs (Total Harmonic Distortion Currents) circulating in the system. In turn, harmonic currents that pass through the power supply circuit (lines and transformers), cause the deformation of the mains voltage: the harmonic distortion in voltage THDU (Total Harmonic Distortion Voltage).

**Consequences:** the damage caused by harmonics can be summarized as follows:

- the electronic power regulation systems may be disturbed by the fact of having to work with voltages that are not perfectly sinusoidal.
- the electronic signal systems, designed to work with very low currents, can easily be "fooled" by the presence of disturbances induced by high-frequency electromagnetic fields.
- the harmonic components of order 3 (150 Hz) in three-phase systems become homopolar, i.e. they converge on the neutral conductor and overload it. In the absence of the neutral, circulating currents may occur inside the three-phase appliances, connected in triangular form, generating dangerous overloads in this situation, too. In single-phase systems, personal computers are classic examples of heavily-distorted loads with a high content of 3rd order harmonics which, as described above, will have an effect on the neutral. The conductor of the latter must therefore be sized appropriately, otherwise overheating will occur, thus reducing its life and quality.

- the magnetic fields generated by the high order harmonics are at high frequency and easily generate unwanted inductive couplings that can produce malfunctions in the most sensitive components such as differentials.

In general, therefore, the economic effects of harmonics can be seen in terms of a shorter useful life of an installation, of a lower yield and a high likelihood of reduced performance.

An Uninterruptible Power Supply (UPS) in a double conversion configuration is a possible solution to the problem of harmonics generated by loads. Since the UPS is interposed between the loads and the mains, it absorbs all the harmonics of the loads and only provides the mains with the harmonics originating from the operation of the UPS itself. These values are certain and defined in the properties shown on the nameplate.

Riello offers UPS with various technological solutions for the input stage ranging from six-pulse or twelve-pulse rectifiers with optional anti-harmonic filters to the ultra-modern IGBT rectifiers with PFC (Power Factor Control).



# UPS CONNECTED IN PARALLEL

## Introduction

UPS can be connected in parallel in order to increase reliability in the supply of power to the load and the power available on output. Up to 8 units can be connected in parallel. Our recommendation is to connect units of the same power.

It is necessary, therefore, to install an electronic card (on each UPS) which guarantees the frequency synchronicity of the UPS connected in parallel together with the mains supply, in order to avoid exchanges of current among the UPS in parallel and between the UPS in parallel and the mains supply (only in inverter/mains and/or mains/inverter switching).

The load that can be applied to a system with multiple machines in parallel can be higher than the load that can be sustained by each unit thanks to automatic power-sharing. Increased reliability is only achieved on condition that the total system power, with one unit deactivated, remains higher than the demand. This condition is always achieved by adding a redundant unit. A redundant unit is obtained with a UPS that is additional to the minimum number of elements required to power the load, so that after the automatic exclusion of a faulty unit, the power supply can continue in a correct manner.

The UPS connected in parallel are coordinated by a board, which controls the exchanges of information. The information is exchanged between the UPS via a cable that connects them in a ring circuit. The ring connection provides a redundancy in the connection cable (communication by cable between the single units). This is the most reliable way to connect the UPS with each other. It also allows the connection and hot disconnection of a UPS.

Each UPS has its own controller that continuously communicates with the entire system so as to ensure correct operation. The cable transmits signals from a "Master" UPS to the other "Slaves" with an opto-isolated system so as to maintain the control systems electrically isolated from each other.

The operating logic provides for one unit, the first one that is activated, to become "Master" and to take control of the other "Slaves". In the event of failure of the "Master" unit, there will be an immediate transfer of control to a "Slave" who in turn will become "Master".

The parallel systems may work with one battery on each UPS module or one battery for the whole system. The exact connection in parallel provides for the connection from a single mains node to the input terminals

of the various UPS, and the connection from their output terminals to a single node for the power supply to the load, with the cables having the same section and total length. This recommendation is necessary to ensure the distribution of power during operation on the by-pass line: UPS in distributed parallel have a static switch for each UPS, while the centralized parallel system (increasingly less used) has a single static switch (with by-pass function) external to the UPS and is dimensioned for the entire power of the parallel system. The distribution of the load in normal operation is automatic. Normally parallel systems are available for UPS with power exceeding 10kVA; further details about the types of configurations can be found in the description of the individual products.

### PARALLEL CONFIGURATION OF UP TO 8 UPS UNITS WITH DISTRIBUTED BYPASS

Parallel architecture to ensure redundancy of the power source. + **Flexibility and modularity and no single point of failure.**

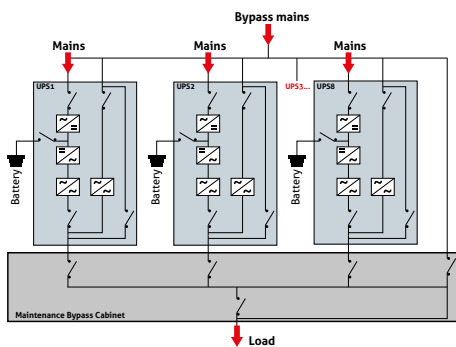

### PARALLEL CONFIGURATION OF UP TO 8 UPS UNITS WITH COMMON BYPASS

Parallel architecture to ensure redundancy of the power source, with autonomous bypass management. + **Selectivity of downstream faults in bypass mode**

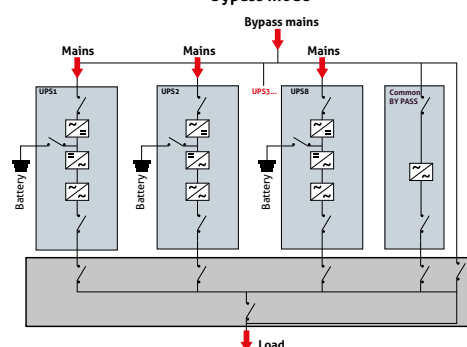

### DYNAMIC DUAL BUS CONFIGURATION

Solution to ensure redundancy up to the distribution of the power supply to the loads and improved STS operation. + **Downstream fault discrimination**

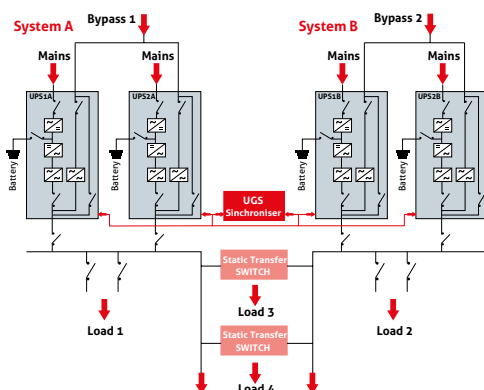

### DUAL BUS SYSTEM CONFIGURATION

Solution to ensure redundancy of the power supply even during maintenance. + **High availability and redundancy**

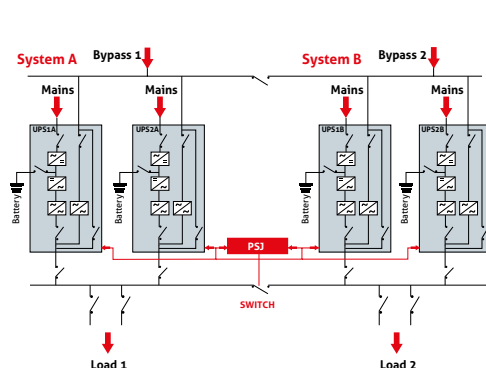

# BATTERIES

The battery is a delicate part of the UPS system. For this reason it is necessary to pay attention to the selection and to the installation conditions. A low-quality battery or one not installed correctly can result in a loss of load.

## Requirements on installing batteries

The internal gas recombination or VRLA batteries, can be installed in places normally frequented by people; in fact, the necessary air exchange is negligible but should not be overlooked, as prescribed in the European standard EN 50272-2. Although VRLA batteries function within the specified temperature limits for UPS, they do have an accelerated ageing if the temperature is higher than the nominal working temperature (20°-25°C). For every 10°C over the nominal temperature the expected life of the battery is halved.

*Example:* battery with a nominal T of 25°C = 4-5 years of life; operating at 35°C the life duration becomes 2-2.5 years.

One normally provides for the replacement of batteries during the life of a UPS.

When positioning the batteries, check the equipment manual to avoid making this operation difficult!

The room where the batteries are located should be maintained at temperatures between 20-25°C to maximize the life expectancy of the batteries; in addition, the area must be at least 2 m high to facilitate installation.

The floor must be able to withstand a load equal to the weight of the batteries, which may reach a total of about 2300-2400 kg/sq.m. The doors of these rooms must open outwards.

When the batteries are mounted inside a cabinet, access must only be possible after the battery has been isolated and a door has been opened using the special tool. The correct charging voltage for the batteries varies according to the ambient temperature.

Modern UPS are able to regulate the charging voltage by means of temperature sensors. In the event of batteries connected externally to the unit and if the room temperature is not stable, it is advisable to mount a temperature sensor which will transmit information to the battery-charger. If the batteries are open vase, they must be installed in a special room following the EN 50272 standard on premises, in particular complying with the air exchange calculation in accordance with the formula specified in paragraph 1.2 of the standard. If forced air ventilation is used, any failure of this must be reported to the UPS so that the battery-charger is stopped, thereby avoiding the possible build-up of hydrogen inside the room.

Batteries are an independent source of energy and so it is absolutely necessary to install a protection device with adjustments appropriate to their capacity and the discharge currents. It is advisable to have a protection device for each battery branch if the batteries were installed with multiple branches in parallel.

## Ventilation requirements for batteries according to the EN50272-2 standard

The batteries shown in this catalogue, are all of the internal gas recombination or VRLA type, also known as sealed Pb batteries. These batteries do not require any particular devices, except in the event of large capacity installations (more than 100 Ah). With larger capacity facilities, it is necessary to provide adequate ventilation.

The purpose of ventilating the room where the batteries are installed is to maintain the hydrogen concentration below the 4% threshold of the Lower Explosion Limit (LEL). The rooms where the batteries are installed are considered safe from the point of view of explosions when the concentration of hydrogen is kept below this safety limit, with natural or forced (artificial) air ventilation. The minimum air flow for ventilating the rooms where the batteries are installed must be calculated in accordance with local specifications. In the absence of such specifications, one can use the European EN 50272 as the reference standard.

# BATTERY CURRENT VALUES CHARGING WITH VOLTAGE-CURRENT CONTROLLED CHARGER

	Open cells of lead batteries	VRLA cells of lead batteries	Open cells of nickel-cadmium batteries
Gas emission factor FG	1	0.20	1
Gas emission safety factor FS	5	5	5
Trickle-charging voltage Ufloat [V/cell]	2.23	2.27	1.40
Typical trickle-charging current Ifloat [mA per Ah]	1	1	1
Current (in buffer) Igas [mA per Ah]	5	1	5
Rapid-charging voltage Uboost [V/cell]	2.40	2.40	1.55
Typical rapid-charging current Iboost [mA per Ah]	4	8	10
Rapid current Igas [mA per Ah]	20	8	50

The trickle-charging and rapid-charging current values increase with temperature. The result of any increase in temperature up to a maximum of 40°C has been taken into account in the values in the table. If recombination vent plugs (catalysts) are used, the I<sub>gas</sub> current that produces gas can be reduced by up to 50% of the values for open cells.

## Natural ventilation

The flow quantity of ventilation air must be ensured, preferably by means of natural ventilation, or else by means of forced (artificial) air ventilation.

The battery rooms or casings for the batteries require an inlet and outlet of air with a minimum, free surface opening calculated according to the following:

$$A = 28 * Q$$

and

Q = flow rate of fresh air for ventilation [m<sup>3</sup>/h]

A = free surface of the air inlet and air outlet opening [cm<sup>2</sup>]

For the purposes of this calculation it is assumed that the air speed is 0.1 m/s.

The air inlet and outlet must be placed in the best possible way to create the most favourable conditions for changing air, for example:

- openings on opposite walls,
- minimum separation distance of 2 m, when the openings are on the same wall.

## Forced air ventilation

When an adequate air flow Q cannot be achieved through natural ventilation and one has to resort to forced air ventilation, the battery-charger must be interlocked with the ventilation system or an alarm must be activated to ensure the required airflow in relation to the chosen charging mode. The air extracted from the batteries must be removed into the atmosphere outside the building.

NOTE: For input/output cable sections sizing please refer to UPS manuals where you can find maximum current indications.







# Services and contacts

# Services

## PRE-SALES CONSULTANCY

tec@riello-ups.com



### The TEC team

Our TEC (Technical Energy Consultant) experts have been working in the power sector for years, and come from backgrounds with technical experience in Data Centre, industry and power plants.

### Consultancy on standards

Regulatory standard consultancy concerning:

- Products and portfolio solutions
- Batteries, flywheels, super capacitors
- Installation and configuration
- Applications (data centres, emergency lighting, electro-medical, railways etc.)

### Work tools

#### Training and information

- UPS sizing
- Official technical guides
- Installation requirements
- TEC newsletters
- Technical specifications
- Online tools (TEC area, UPS configurator, runtime calculation, etc.)

### Technical seminars

Seminars can be requested by engineering firms or end customers directly and can also be proposed by TEC for sector associations and colleagues.

### Design support

The TEC team can provide technical assistance concerning the choice, sizing and installation of our products and solutions.

### Help Desk

The TEC service is available by phone, fax or e-mail to answer your requests immediately.

### Witness test

The witness test service is provided for checking solutions before transport to the installation site.

## RENTING



### Why rent?

- Renting a UPS system from Riello is an ideal way to protect your investment from the risks of technological obsolescence and the limitations of ownership
- Renting does not require any minimum duration obligations and the fees are considered as operating costs and are therefore tax deductible.
- By renting a UPS, the customer enjoys the benefits of using the latest technologies without the disadvantages of ownership.

### Advantages

- Immediate UPS availability.
- Maintenance and assistance for the entire duration of the rental lease.
- Variable and flexible rental contracts.
- Increased reliability thanks to the presence of constantly updated UPS.
- Fully comprehensive insurance.

### Guaranteed services

- Dedicated freephone number.
- Dedicated e-mail address.
- Guide for choosing a UPS.
- Priority intervention thanks to the extensive network of Riello Service Centres.
- Remote monitoring.
- Removal of old UPS.

## TECHNICAL ASSISTANCE

service@riello-ups.com



### The Service team

Our technical assistance facility uses highly trained engineers to provide a reliable and competent technical support and efficient after-sales service.

### The services

Service can provide customers with:

- a dedicated call-centre for direct contact with the Service organisation. Service personnel are always available and ready to provide advice and assistance regarding UPS installation and maintenance.
- The new free swap assistance service
- an on-site support service for larger UPS that cannot be transported, whether or not they are covered by the warranty. A fast repair on site is guaranteed through the use of state-of-the-art UPS technology, the professionalism of the Service personnel and Authorised Assistance Centres nationwide. Service guarantees that any spare parts used are original, tested and up-to-date.

- Service can provide assistance during the installation and initial start-up of the products and train on-site personnel. Technical Service engineers can also verify site suitability, analyse and advise on rental solutions and disconnect and relocate equipment
- Maintenance contracts can be provided by Service to minimise the risks and costs connected with UPS breakdowns. Many types of maintenance contract are available, ranging from periodic inspections to comprehensive cover including labour and materials.
- Service regularly organises technical training courses for technicians at the Riello UPS training centre.



**Service  
1st start**

## RIELLO CONNECT REMOTE MONITORING SERVICE



- Riello Connect from Riello UPS is a remote monitoring service designed to increase resilience and reduce downtime of your mission critical equipment. Riello Connect offers the invaluable peace of mind that comes from knowing the performance of your Riello UPS and battery systems are being continually monitored by trained Riello UPS technical specialists. Utilising the Riello Connect system, our UPS technicians can identify problems before they become load loss events. In the event of a UPS alarm, the Riello Connect system can notify your chosen first response contact (via SMS or e-mail) 24/7 365. Meanwhile, an authorised Riello Service Technician remotely investigates and takes action appropriate to your individual service Contract.
- Riello technical specialists continually monitoring your Riello Uninterruptible Power Supply;
  - Receive alarm notification by SMS or email;
  - Receive regular performance reports for your UPS from the Riello Connect data centre, where the historical performance data is stored and analysed.

# Operating Offices

**RPS S.p.A.**

**ITALY**

**LEGNAGO (VR)**

**Head Office**

Viale Europa, 7  
37045 LEGNAGO (Verona)  
Tel +39 0442 635811  
www.riello-ups.com  
riello@riello-ups.com

**CORMANO (MI)**

**Sales Office**

Via Somalia, 20  
20032 CORMANO (Milano)  
Tel +39 02 663271



**PRE-SALES SUPPORT** (TEC)  
tec@riello-ups.com



**AFTER-SALES SUPPORT** (UPService)  
service@riello-ups.com





## USA

### **RPS America, Inc.**

8808 Beckett Rd  
West Chester, OH 45069  
Tel +1-513-282-3777

## UNITED KINGDOM

### **RIELLO UPS Ltd.**

Unit 50 Clywedog Road North  
Wrexham Industrial Estate  
Wrexham LL13 9XN  
Tel +44 800 269 394

### **CONSTANT POWER SERVICES Ltd.**

Riello House, Works Road,  
Letchworth  
SG6 1AZ Hertfordshire  
Tel +44 330 1230125

## GERMANY

### **RIELLO UPS GmbH**

Wilhelm-Bergner-Str. 9b  
21509 Glinde  
Tel +49 40 / 527 211-0

### **RIELLO POWER SYSTEMS GmbH**

Neufahrner Str. 12b  
85375 Neufahrn/Grüneck  
Tel +49 8165 / 9458-0

## FRANCE

### **RIELLO ONDULEURS S.a.r.l.**

2/4 Rue du Bois Chaland,  
ZAC du Bois Chaland  
91090 Lisses  
Tel +33 1 60 875454

## SPAIN

### **RIELLO ENERDATA s.l.u.**

C/ Labradores,  
13 Parque Empresarial  
Prado del Espino  
28660 Boadilla del Monte  
Madrid  
Tel +34 916 333 000

### **RIELLO TDL s.l.**

C/Berguedà, 6 bis  
Pol. Ind. Plà de la Bruguera  
08211 Castellar del Vallès, Barcelona  
Tel +34 902 02 66 54

## ROMANIA

### **RIELLO UPS ROMANIA S.r.l.**

Str. Varsovia Nr. 4  
307160 Dumbravita  
Timis County - Romania  
Tel +40 256 214 681

## POLAND

### **RIELLO DELTA POWER Sp. z o.o.**

ul. Krasnowolska 82 R  
02-849 Warszawa  
Tel +48 22 379 17 00

## AUSTRALIA

### **RIELLO UPS AUSTRALIA Pty. Ltd.**

Unit 22/80 Box Road  
Taren Point NSW 2229  
Tel +61 2 9531 1999

## ASIA PACIFIC

### **RIELLO UPS SINGAPORE Pte Ltd.**

No. 506 Chai Chee Lane,  
#07-01, Singapore 469026  
Tel +65 6441 2005

## CHINA

### **Riello UPS (Asia) Co., Ltd.**

Bolg2, No.451 Duhui Road,  
Minhang District-201108  
Shanghai  
Tel +86 21 50464748

## INDIA

### **RIELLO POWER INDIA Pvt. Ltd.**

287-288 Udyog Vihar, Phase II  
122015 Gurgaon (HR)  
Tel +91-124-4111999

## ARABIAN PENINSULA

### **RIELLO UPS Middle East FZ-LLC**

Dubai Science Park  
North Tower, 8th Floor, Office 9  
Al Barsha South, 500767  
Tel. +971 55 7672503

[www.riello-ups.com](http://www.riello-ups.com)

Follow us on Social Networks



















**Reliable power for a sustainable world**



**Delivering total power solutions**





## Constant Power Services

Riello House, Works Road, Letchworth, Herts SG6 1AZ

Tel: 0330 123 0125 Fax: 01462 422 754

[sales@constantpowerservices.com](mailto:sales@constantpowerservices.com)

[service@constantpowerservices.com](mailto:service@constantpowerservices.com)

Constant Power Services Ltd is certified ISO9001, ISO14001 & OHSAS18001

Constant Power Services Ltd is a wholly owned subsidiary of Riello Elettronica, Italy

Follow us on Social Networks



Product photos are purely indicative. Due to technical improvements and/or changes in regulatory standards, product specifications are subject to change without notice.