

**G2**

**C-Frame  
Double Crank Power Presses**

C型ダブルクランクプレス



110. 160. 200. 250. ton

# G2

## C-Frame Double Crank Power Presses

C型ダブルクランクプレス

**Productivity** 生産力アップ  
**Reliability** 高い信頼性  
**Operability** 容易な操作性



Stroke-Capacity Diagram ( V )  
ストローク/能力曲線図(V)

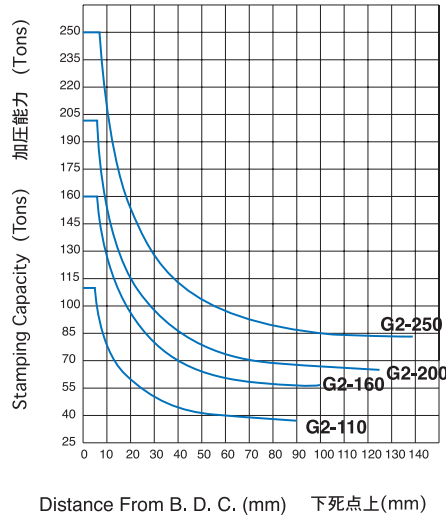

Stroke-Capacity Diagram ( H )  
ストローク/能力曲線図(H)

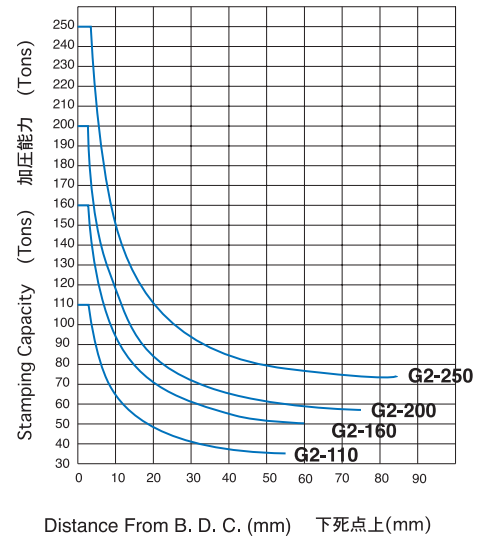

SPECIFICATIONS 仕様

機 種 TYPE	機 種 形 式	MODEL	G2-110		G2-160		G2-200		G2-250	
			V	H	V	H	V	H	V	H
Capacity	能 力	Tons	110		160		200		250	
Rated Tonnage Point (Above B.D.C.)	能力発生点	mm	5	3	6	3	6	3	7	3.5
Stroke Length	ストローク長さ	mm	180	110	200	130	250	150	280	170
Strokes Per Minute	ストローク数	S.P.M.	35-65	50-100	30-55	40-85	25-45	35-70	20-35	30-60
Die Height (S.D.A.U.)	ダイハイト	mm	400	350	450	400	500	450	550	450
Maximun Upper Die Weight	最大上型重量	kg	800		1270		1470		1560	
Slide Adjustment	スライド調整量	mm	100		100		120		120	
Bolster Area (L.R. x F.B.)	ボルスター面積	mm	1800 x 650		2000 x 760		2400 x 840		2700 x 900	
Bolster Thickness	ボルスター厚さ	mm	130		150		160		160	
Slide Plate Area (L.R. x F.B.)	スライド面積	mm	1400 x 500		1600 x 550		1850 x 650		2100 x 700	
Slide Plate Thickness	スライド板厚さ	mm	70		70		95		95	
Shank Hole	シャンク穴の寸法	mm	Ø50 x 3 x Pitch 320		Ø50 x 3 x Pitch 350		Ø50 x 3 x Pitch 375		Ø50 x 3 x Pitch 450	
Main Motor	主電動機	HP x P	10 x 6		15 x 6		20 x 6		25 x 6	
		KW x P	7.5 x 6		11 x 6		15 x 6		19 x 6	
Slide Adjusting Motor	スライド調整モーター	HP x P	1 x 4		1 x 4		2 x 4		2 x 4	
		KW x P	0.75 x 4		0.75 x 4		1.5 x 4		1.5 x 4	
Air Supply Requirement	使用空気圧	Kg/cm <sup>2</sup>	5		5		5		5	
Precision	精 度		JIS (CNS) First Class				JIS (CNS)一級			
Die Cushion	ダイクッション		2 - Pad - 2 - Cylinder 2 - パッド, 2 - シリンダ -							
Capacity	能 力	Tons	3.6 x 2		6.3 x 2		10 x 2		14 x 2	
Air Pressure	使用空気圧	Kg/cm <sup>2</sup>	6.5		7.2		6.75		9	
Stroke Length	ストローク長さ	mm	70		70		80		100	
Pad Area (L.R. x F.B.)	パッド面積	mm	350 x 235 x 2pcs		410 x 260 x 2pcs		540 x 350 x 2pcs		640 x 470 x 2pcs	

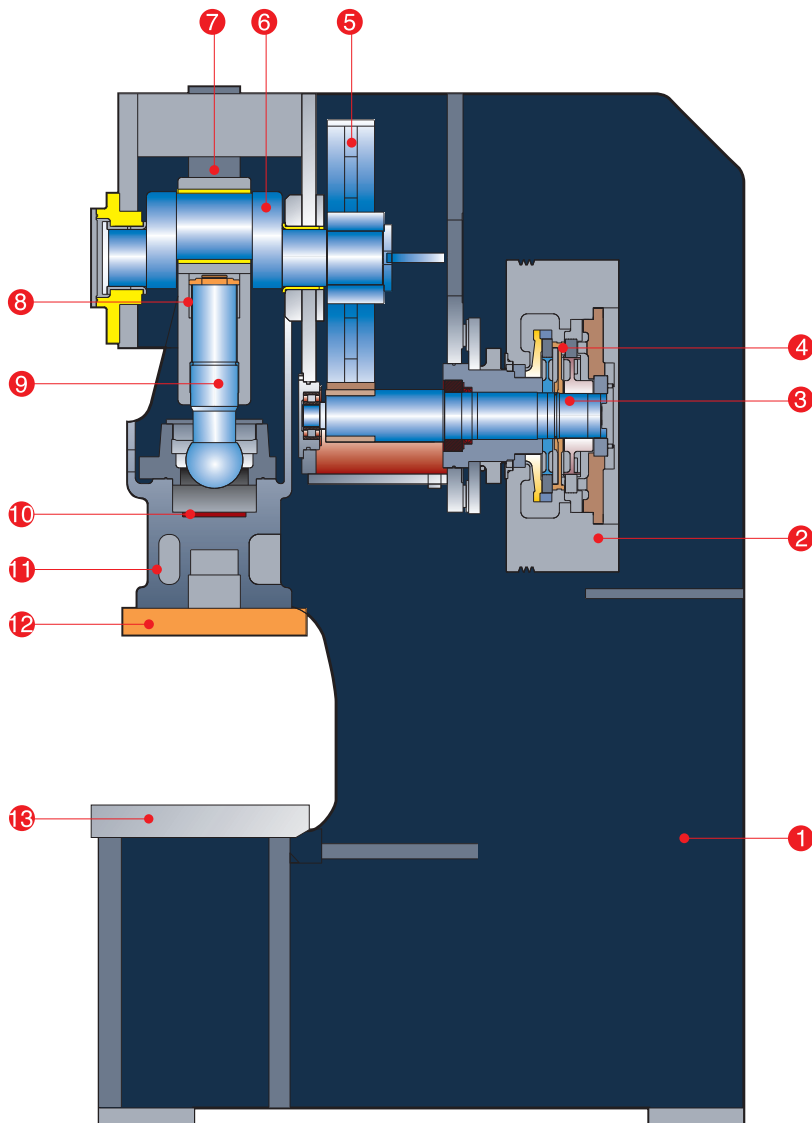

- |                              |                     |
|------------------------------|---------------------|
| 1. Frame                     | 1. フレーム             |
| 2. Flywheel                  | 2. フライホイール          |
| 3. Pinion Shaft              | 3. ピニオンシャフト         |
| 4. Wet Type Clutch & Brake   | 4. 湿式クラッチブレーキ       |
| 5. Main Gear                 | 5. メインギヤー           |
| 6. Crank Shaft               | 6. クランクシャフト         |
| 7. Counter Balancer          | 7. スライドバルancer      |
| 8. Connecting Rod            | 8. コンロッド            |
| 9. Adjusting Screw           | 9. スクリュー            |
| 10. Chamber of H.O.L.P.      | 10. 油圧室             |
| 11. Slide                    | 11. スライド            |
| 12. Slide Plate (detachable) | 12. スライドプレート(取外し可能) |
| 13. Bolster                  | 13. ボルスター           |

## High Performance Wet Clutch & Brake 高トルク湿式クラッチブレーキ

The CHIN FONG clutch delivers high torque at relatively low air pressure, and with a low moment of inertia. Modern, suited clutch and brake friction linings combine high performance with low vibration and noise. The linings run in an enclosed oil bath, providing very efficient heat dissipation. Together, these superior features add up to a high performance, efficient, long-lived clutch, with reduced lining wear and air consumption, even at high single-stroke rates of production.

高性能/高効率  
低イナーシャ/高トルク  
低騒音/無粉塵  
使用寿命長い/フリーメンテナンス  
メンテナンスコスト低化

## Highly Responsive Hydraulic Overload Protector (H.O.L.P.) 高敏感度オーバーロードプロテクター

高敏感度オーバーロードプロテクター  
すみやかに反応し、瞬間に油圧を開放します。

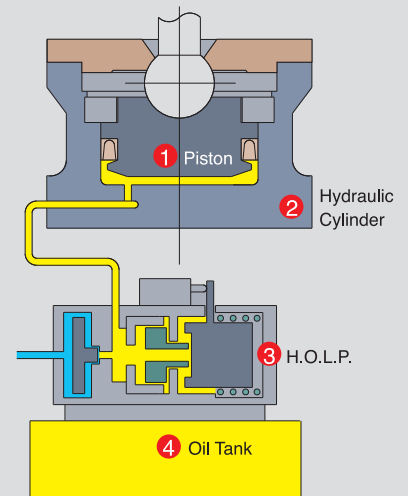

Highly responsive, with an immediate oil dump feature and a unique dual-valve/pressure switch arrangement, Chin Fong fast-acting H.O.L.P. relieves the pressure of a tonnage overload in milliseconds, and helps protect both press and tooling. If an overload occurs, even on just one side of the press, oil pressure in the cylinder is released and, simultaneously, the press stops. This reliable system can be quickly and easily reset by inching the slide back to top dead center, which automatically reactivates the pump and builds up hydraulic pressure to the pre-overload setting, and allows resumption of normal operation.

- |                  |
|------------------|
| 1. 油圧ピストン        |
| 2. 油圧シリンダー       |
| 3. オーバーロードプロテクター |
| 4. オイルタンク        |

### Super Rigid Steel Frame 高剛性フレーム

最適剛性配分のフレーム設計で、製品加工精度を大幅にアップします。

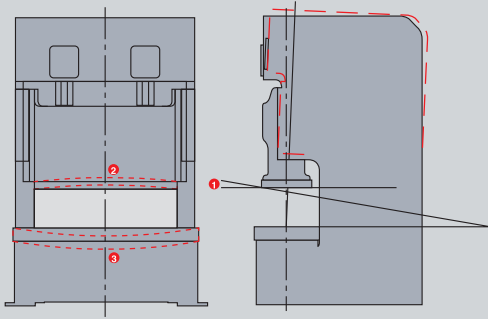

The CHIN FONG G2 Series is designed to resist deflection, and provide accurate pressings and longer die life, even at full tonnage loads. The heavy, one-piece welded steel frame is fully stress relieved and designed to provide a stable base for the G2 Series presses.

### Two-pump design offers sensitive detection for eccentric over loading. It improves the accuracy maintenance

二つのポンプがあるため、偏心荷重に速やかに反応します。スライドの平行精度を維持するには有利です。

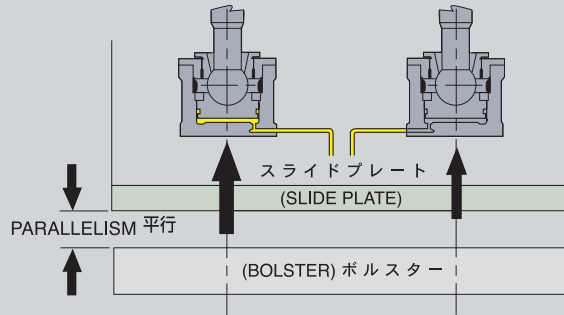

If unequal loads are applied across the slide, full oil pressure from the overload system is applied where required to retain the parallelism between slide plate and bolster for consistent quality of pressings and extended tooling life.

### Unique Slide Knockout Device スライドノックアウト装置

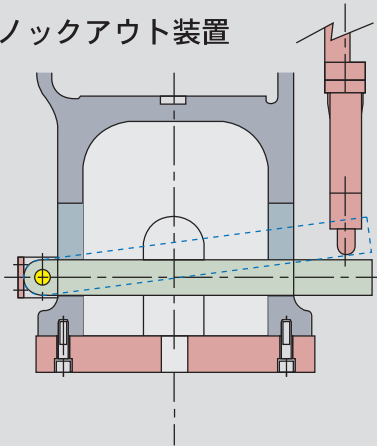

The slide plate is separated from slide. This design can vary according to the request of customers for employing slide knockout device, either mechanical or air cylinder type as option.

### Extra Long, Precise, Six-Point, Centered Box Type Gibbing

センター式六面ガイド  
高い動的精度と金型寿命の大幅アップ

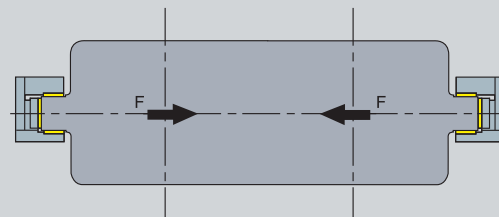

One-piece, full-length, box type centered gibs assure actuated slide guiding, and provide better control of slide alignment than rear-mounted gibs. Force is delivered vertically, minimizing lateral thrust and, consequently reducing off-center loading and friction in the gibs. Clearance settings (front to back and left to right) are accomplished by push-pull type screws, and maintained to factory tolerances by the use of laminated spacers.

(For reference only. Select the items below properly as needed. 下記の型式、仕様及び数量の選択配合は参考のみ)

## Quick Die Change System 便利な金型交換装置 (Q. D. C. S.)

### Die Clamp TX-type TX-ダイクラムパー With "U" Cut in die set 金型取付板U溝

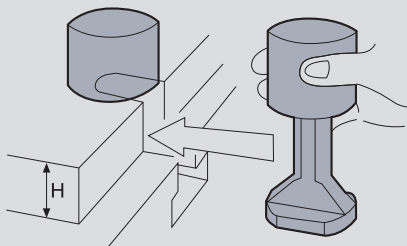

### Die Clamp TY-type TY-ダイクラムパー

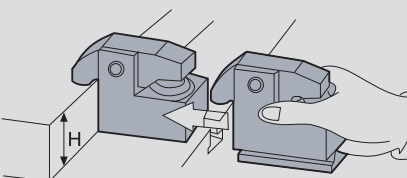

Die plate thickness, H, to be specified  
金型取付板U溝 (厚さをご確認ください)

		Qty 数量		Model 機種			
Option 選択配置				G2-110	G2-160	G2-200	G2-250
Die Clamp ダイクラムパー	Upper 上型	TX-4 or TY-4 TX-4 或いはTY-4	Clamping Force 4 tons/PCS クランプ能力4トン/個	8	8	8	8
		TX-6 or TY-6 TX-6 或いはTY-6	Clamping Force 6 tons/PCS クランプ能力6トン/個				
	Lower 下型	TX-4 or TY-4 TX-4 或いはTY-4	Clamping Force 4 tons/PCS クランプ能力4トン/個	8	8	8	8
		TX-6 or TY-6 TX-6 或いはTY-6	Clamping Force 6 tons/PCS クランプ能力6トン/個				
Die Lifter ダイリフター		DL-28-600	Pay Load 880kg/PCS 耐荷重880キロ/本	4			
		DL-28-700	Pay Load 1040kg/PCS 耐荷重1040キロ/本		4		
		DL-28-800	Pay Load 1200kg/PCS 耐荷重1200キロ/本			4	
		DL-28-900	Pay Load 1360kg/PCS 耐荷重1360キロ/本				4
Die Arm ダイアーム		RC-700-600	Pay Load 600kg/PCS 積載荷重 600 キロ/本	4	4		
		RC-800-800	Pay Load 800kg/PCS 積載荷重 800 キロ/本			4	
		RC-900-900	Pay Load 900kg/PCS 積載荷重 900 キロ/本				4
Hydraulic Power Unit FP6308U 油圧パワーユニットFP6308U						1	

# BOLSTER

ボルスタ-

Fig. 1 図面一

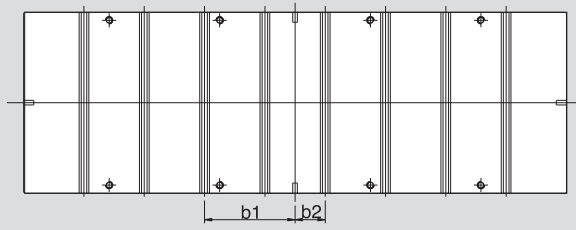

Fig. 2 図面二

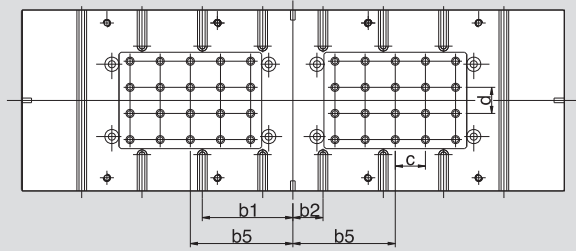

Fig. 3 (with "u"slot for die lifter) 図面三(ダイリフター用 "U" 溝含む)

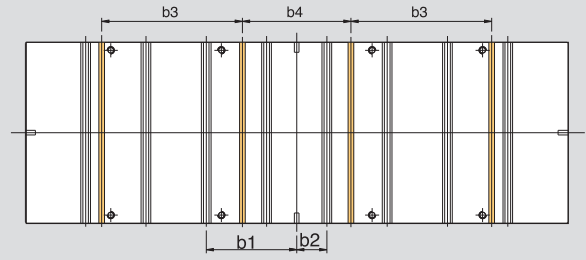
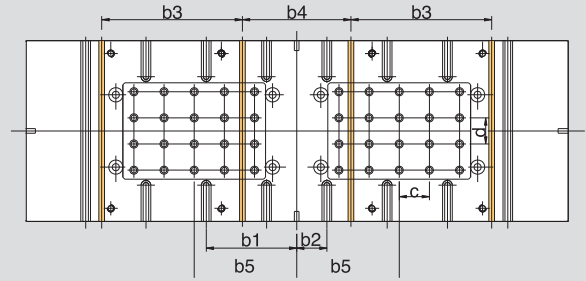

Fig. 4 (with "u"slot for die lifter) 図面四(ダイリフター用 "U" 溝含む)



unit: mm

MODEL	機種	G2-110	G2-160	G2-200	G2-250
Bolster Area (LR x FB)	ボルスタ-面積 (左右 x 前後)	1800 x 650	2000 x 760	2400 x 840	2700 x 900
Type of T-Slot	T溝型番	A	A	B	B
No. of T-Slot	T溝数	6	8	8	8
	b1	375	375	375	450
	b2	125	125	125	150
	b3	320	520	710	680
	b4	430	520	520	540
	b5	255	415	455	510
Fig 2, Fig 4	No. of Pin Hole x Dia. ダイクッションホル数 x ピン穴	30 x $\varnothing 20^{+0.5}_{+0.1}$	48 x $\varnothing 20^{+0.5}_{+0.1}$	48 x $\varnothing 28^{+0.5}_{+0.1}$	70 x $\varnothing 28^{+0.5}_{+0.1}$
図面二、四	c x d ホールピッチ	75 x 100	75 x 75	100 x 100	100 x 100

# SLIDE PLATE

スライドプレート加工図

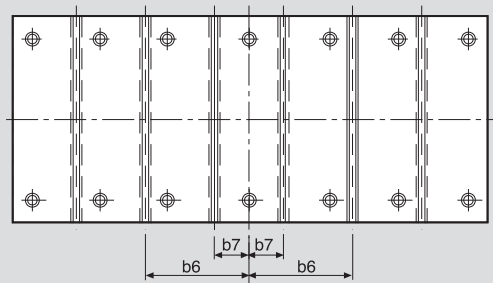

unit: mm

# T-Slot Detail

T溝詳細

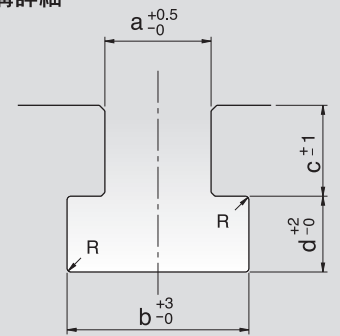

unit: mm

MODEL	機種	G2-110	G2-160	G2-200	G2-250
Slide Plate Area (LR x FB)	スライド面積 (左右 x 前後)	1400 x 500	1600 x 550	1850 x 650	2100 x 700
Type of T-Slot	T溝型番	A	A	B	B
No. of T-Slot	T溝数	4	6	6	6
	b6	375	375	375	450
	b7	125	125	125	150

Dim.寸法	Type 型番	A	B
a		22	28
b		37	48
c		24	28
d		16	20
R		1	1

## OUTLINE DIMENSIONS

外型寸法

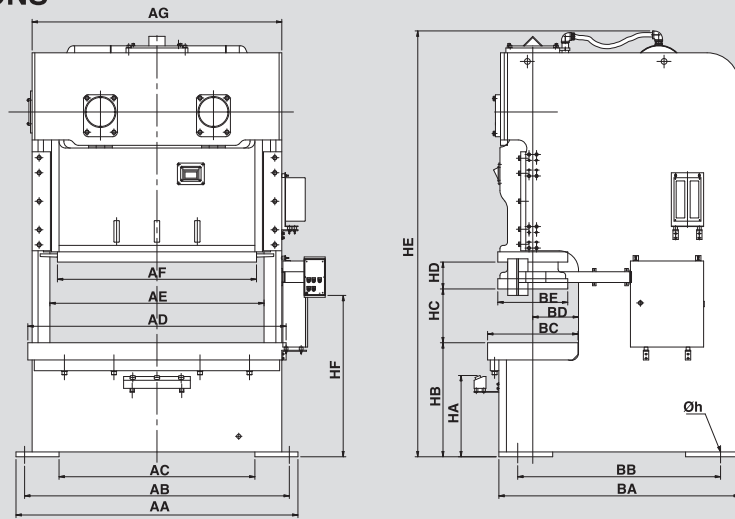

unit: mm

MODEL	機種	G2-110		G2-160		G2-200		G2-250	
TYPE	型式	V	H	V	H	V	H	V	H
AA		2000		2200		2620		3000	
AB		1900		2080		2460		2800	
AC		1360		1520		1820		2200	
AD		1800		2000		2400		2700	
AE		1510		1660		1990		2230	
AF		1400		1600		1850		2100	
AG		1780		1980		2320		2590	
BA		1745		1940		2165		2470	
BB		1295		1380		1815		2120	
BC		650		760		840		900	
BD		330		385		425		455	
BE		500		550		650		700	
HA		(630)		(690)		(790)		(820)	
HB		830		950		1060		1090	
HC		400	350	450	400	500	450	550	450
HD		180	110	200	130	250	150	280	170
HE		3220	3135	3660	3575	3960	3860	4335	4180
HF		1170		1330		1500		1610	
Øh		Ø35		Ø47		Ø54		Ø54	

## Standard Functions / Accessories

## 標準付属品

- |   |   |  |   |
|---|---|--|---|
| <ul style="list-style-type: none"> <li>▪ Fixed Type Operation Stand</li> <li>▪ E-Series Control System                     <ul style="list-style-type: none"> <li>▪ Electronic Crank Angle Display</li> <li>▪ Electronic SPM Display</li> <li>▪ LCD type Press status monitor</li> </ul> </li> <li>▪ Operation Mode Selection<br/>Off / Inching / Safety One Stroke / Continuous</li> <li>▪ Hydraulic Overload Protector (H.O.L.P.)</li> <li>▪ Overrun Detector (Brake Monitor)</li> <li>▪ Dual-safety Solenoid Valve</li> <li>▪ Digital Die Height Indicator (unit:0.1mm)</li> </ul> | <ul style="list-style-type: none"> <li>▪ Total Counter, 6 digits</li> <li>▪ Preset Counter, 6 digits</li> <li>▪ Maintenance Counter, 4 digits (unit:10K)</li> <li>▪ Life Counter, 10 digits</li> <li>▪ Electronic Rotary Cam Switch ( 6 spare channel )</li> <li>▪ Air Ejector, 3/8", one channel</li> <li>▪ Misfeed Detection Consent</li> <li>▪ Motorized Slide Adjusting Device</li> <li>▪ Inverter with main motor reversing circuit</li> <li>▪ Manual Grease pump</li> </ul> | <ul style="list-style-type: none"> <li>• 固定式両手押しボタン操作盤</li> <li>• Eシリーズコントロールシステム (HMI操作盤付きPLC)                     <ul style="list-style-type: none"> <li>• 電子式クランク角度指示計</li> <li>• 電子式運転スピード指示計</li> <li>• 運転状態LCD監視装置</li> </ul> </li> <li>• 運転モード選択スイッチ<br/>切/寸動/安全-行程/連続</li> <li>• 油圧オーバーロード保護装置</li> <li>• 二度落ち検知回路</li> <li>• ダブルソレノイドバルブ</li> </ul> | <ul style="list-style-type: none"> <li>• デジタルダイハイト指示計 (単位0.1mm)</li> <li>• トータル カウンター6桁</li> <li>• プリセットカウンター6桁</li> <li>• メンテナンスカウンター4桁(単位: 万)</li> <li>• 寿命カウンター10桁</li> <li>• 電子式ロータリカム(予備6連)</li> <li>• エアーエジェクター3/8"1回路</li> <li>• ミスフィード検知コンセント二回路</li> <li>• 電動式スライド調整装置</li> <li>• インバーター及びメインモーター正逆転装置</li> <li>• 手動式グリース潤滑給油装置</li> </ul> |
|---|---|--|---|

## Optional Functions / Accessories

## オプション

- |  |   |   |  |
|--|---|---|--|
| <ul style="list-style-type: none"> <li>▪ Die Cushion</li> <li>▪ VS Motor<br/>(Not Applicable to E-Series Control System)</li> <li>▪ Safety Light Curtain</li> <li>▪ Slide Knockout Device</li> <li>▪ Motorized Grease Pump</li> <li>▪ Portable T- Stand Two-hand "RUN" Pushbutton Panel</li> <li>▪ Safety Die Block with Plug</li> <li>▪ Dual Valve with Detector</li> <li>▪ Cut counter(3 digits)</li> <li>▪ Flywheel Brake Device</li> </ul> | <ul style="list-style-type: none"> <li>▪ Power Take-off Shaft</li> <li>▪ Crankshaft Front-end Extension</li> <li>▪ Left-hand-side Frame Extension<br/>(Feed Direction: Left to Right)</li> <li>▪ Quick Die Change System</li> <li>▪ Anchor Bolts &amp; Foundation Plates</li> <li>▪ Anti-vibration Rubber mounts</li> <li>▪ Die area Light</li> <li>▪ Control System(MPC Series)</li> <li>▪ Power receptacle<br/>(Single phase,110V or 220V power source wiring by user)</li> </ul> | <ul style="list-style-type: none"> <li>• ダイクション</li> <li>• VSモーター<br/>(Eシリーズ電気制御では使用できません)</li> <li>• 光線式安全装置</li> <li>• スライドノックアウト装置</li> <li>• 電動式グリース潤滑給油装置</li> <li>• ポータブル式両手操作盤</li> <li>• 安全ブロック&amp;プラグ</li> <li>• ソレノイドバルブ検知付き</li> <li>• カットカウンター(3桁)</li> <li>• フライホイールブレーキ</li> </ul> | <ul style="list-style-type: none"> <li>• 自動化取出軸                     <ul style="list-style-type: none"> <li>• クランク前端タイプ</li> <li>• フレーム左側タイプ<br/>(送り方向左→右)</li> </ul> </li> <li>• 金型交換装置(Q.D.C.S.)</li> <li>• 基礎ボルト&amp;プレート</li> <li>• 防振装置</li> <li>• ダイライト</li> <li>• コントロールシステム(MPCシリーズ)</li> <li>• 電源コンセント110V/220V単相<br/>(電源はお客様手配とする)</li> </ul> |
|--|---|---|--|



INNOVATION、SERVICE、COMMITMENT

沖壓機械專業製造廠

**金豐機器工業股份有限公司**

**CHIN FONG MACHINE INDUSTRIAL CO., LTD.**

**HEAD OFFICE & FACTORY:**

總公司：台灣省彰化市彰水路186號  
186 Chang Shui Road, Chang Hua, Taiwan  
<http://www.chinfong.com.tw>  
E-mail: [sales@chinfong.com.tw](mailto:sales@chinfong.com.tw)  
TEL: +886-4-752-4131  
FAX: +886-4-761-1920, 761-2814

北區營業所 **TAIPEI OFFICE**

TEL: +886-3-435-5058

FAX: +886-3-463-9648

南區營業所 **KAOSHIUNG OFFICE**

TEL: +886-7-238-5689~90

FAX: +886-7-238-5691

**金豐（中國）機械工業有限公司**  
**CHIN FONG (CHINA)**  
**MACHINE INDUSTRIAL CO., LTD.**

寧波市鎮海經濟開發區金豐路3號  
3 Chin Fong Road, Zhenhai Economic  
Development Zone, Ningbo, China  
<http://www.chinfong.com.cn>  
E-mail: [ge0107@chinfong.com.cn](mailto:ge0107@chinfong.com.cn)  
TEL: +86-574-8630-1222  
FAX: +86-574-8630-3709

**STAMTEC**

**U.S.A.: STAMTEC INC.**

4160 Hillsboro Highway Manchester, TN 37355, U.S.A.  
<http://www.stamtec.com>  
E-mail: [Sales@stamtec.com](mailto:Sales@stamtec.com)  
TEL: +1-931-393-5050  
FAX: +1-931-393-5060

**OVERSEAS BRANCHES**

**THAILAND: CHIN FONG (THAILAND) CO., LTD.**

E-mail: [t1451@chinfong.com.tw](mailto:t1451@chinfong.com.tw)

TEL: +66-2-919-6820~2 FAX: +66-2-919-6823

**INDONESIA: PT. CHIN FONG INDONESIA**

E-mail: [hay\\_hsu@chinfong.web.id](mailto:hay_hsu@chinfong.web.id)

TEL: +62-21-450-7422 FAX: +62-21-458-44197

**MALAYSIA: CHIN FONG MACHINE (M) SDN BHD**

E-mail: [chinfongmachine@gmail.com](mailto:chinfongmachine@gmail.com)

TEL: +60-3-3290-6827~9 FAX: +60-3-3290-6830



The contents disclosed in this catalogue, including pictures, data, wordings & drawings, are exclusive property of Chin Fong Machine Industrial Co., Ltd. Unauthorized duplication or use part or whole of this catalogue is prohibited. Chin Fong reserves rights to modify the specifications & features, due to product improvements, without further notification. optional accessories showing on this picture are for reference only.

上記資料及び挿図は当社の所有で、無断使用、真似は遠慮下さい。産品改良の為、予告なく設計変更を行う事も有ります。ご了承下さい。