

Backline

Product Overview

Materials Handling





Stainless Steel Stackers Truck
Reel, Drum, Barrel, Tool and Die Handling

The Mk5 Compac Mobile Lifter

Designed to lift, transport and position loads, the Compac has been the name associated with top quality, reliable, Stainless Steel lifters for many years and the latest model, the Mk5, has been developed following extensive market research into the lifting and handling needs of today's modern production environment.

The Compac is flexible in design, ergonomic, operator friendly, easy to use and with its range of features and functionality, it meets the needs of today's lifting requirements.

Stainless Steel Construction

Primarily manufactured from Stainless Steel, the Mk5 is ideal for industries where hygiene and resistance to chemicals is of paramount importance, including:-

- Food & Dairy
- Medical
- Chemical
- Pharmaceutical
- Cosmetic

Model Range

Available in three standard models with maximum capacities of 150kg and 300kg, along with a variety of frame configurations and a comprehensive range of attachments, the Compac is an ideal choice for most lifting applications.

Compact and Manoeuvrable

With a small footprint and easy operation, the Mk5 can be used in confined work spaces and narrow production lines.



Technical Data

Stainless Steel construction

C150 = SWL of 150kg
C300 = SWL of 300kg

Small footprint

Engineered to the latest Health & Safety Regulations



Contact Us

01202 307700
01202 722066

info@packline.co.uk
www.packline.co.uk



Technical Data

Control Panel to meet Health & Safety Regulations

Rear Castor Foot Guards

240v or 110v Charging

IP65 Kit - optional

CE Approved



Contact Us

01202 307700
01202 722066

info@packline.co.uk
www.packline.co.uk

Quality of Build and Reliability

Engineered and tested to our own exacting quality standards and using only fully approved components, the Compac has been designed to provide a low maintenance, reliable machine, that has been built to last.

The Mk5 has been designed to meet latest Health & Safety directives, CE approved with supporting risk assessment, technical files and documentation.

The Mk5 Compac has been designed to ensure ease of use, reliability and operator safety.

Safety

Great care has been taken with the design of the Compac to ensure it meets the latest Health & Safety Regulations, including features such as:-

The Control Panel

The Control Panel has been designed to house all instrumentation and information in one central area, visible to the operator at a glance, including:-

- Emergency stop
- Charging socket with dust proof cover - 240v or 110v charging systems can be offered as standard
- Battery condition meter and charging light
- Overload warning light - The provision of an integral electronic overload trip isolates the machine should its capacity be exceeded
- Information panel including capacity ratings

Castor Guards

Guards are attached to the rear castors to prevent accidental crushing of operator's feet

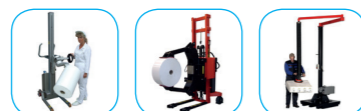

Ergonomics

To ensure operator comfort, safety and limit fatigue, the Mk5 Compac has been designed around the relevant British Standards and ergonomic guidelines. Specific areas of consideration include:-

User Friendly Handlebars

The horizontal and vertical sloping handlebars have been ergonomically designed to provide operator comfort, whilst offering maximum control.

Handheld Control Unit (Optional)

The Compac can be supplied with a handheld control unit, allowing the operator much greater flexibility when positioning loads or aligning attachments.

Interchangeable Wheels

A series of interchangeable wheels are available to cater for different applications, clearance heights and pallet types. These include:-

- Swivel Castors
- Fixed Pallet Wheel
- Rocking Pallet Wheel



Technical Data

Ergonomic Handlebars

Handheld Control Unit optional

Interchangeable Wheels



Contact Us

01202 307700
01202 722066

info@packline.co.uk
www.packline.co.uk

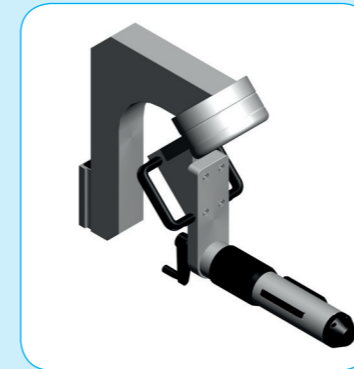

Technical Data

Lifting Capacity
200 kg / 440 lbs

76mm / 3inch Cores
152mm / 6 inch Cores
70mm Cores

Various Diameters and
Widths Catered for

Manual Rotation



Contact Us

01202 307700
01202 722066

info@packline.co.uk
www.packline.co.uk

Vertical Spindle Attachment - Manual

Used to lift and rotate reels of material by gripping the reels' core the Vertical Spindle is available in a wide range of sizes and configurations.

This attachment is used most frequently when reels of material are delivered to site stood vertically, or chimney stacked, on a pallet and need to be rotated into the horizontal to load into a machine.

As standard, a large majority of reels come with core sizes at either 76 or 152mm. This is the equivalent of 3 or 6 inches. If your reels sit outside these core sizes we can build a system to suit.

Most reel sizes can be catered for, please provide Packline with the details so that we can assess which model to offer.

To ensure that a suitable gripping force is created on the core itself there is a Built-in Torque Limiter. Once the appropriate torque has been reached the slip clutch mechanism will be activated ensuring that the operator cannot over-tighten the fingers and damage the core.

Overview

- Standard Core sizes catered for 70/76/152mm or 3 and 6 inches
- Manual Rotation
- Manual Core Gripping with 8NM Torque unit as standard
- Standard Spindle length 330mm / 13inches or 430mm / 17inches

All of the Packline Attachments are interchangeable. If you have the base stacker truck you can use it for more than one task by swapping over attachments simply and without the need for tools.

Heavy Duty Designs and Variation Available - see page 10

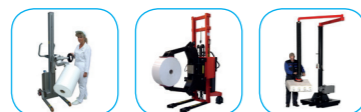

Vertical Spindle Attachment - Geared

Used to lift and rotate reels of material by gripping the reels' core, the Vertical Spindle is available in a wide range of sizes and configurations.

This attachment is used most frequently when reels of material are delivered to site stood vertically, or chimney stacked, on a pallet and need to be rotated into the horizontal to load into a machine.

As standard, a large majority of reels come with core sizes at either 76 or 152mm. This is the equivalent of 3 or 6 inches. If your reels sit outside these core sizes we can build a system to suit.

Most reel sizes can be catered for, please provide Packline with the details so that we can assess which model to offer.

To ensure that a suitable gripping force is created on the core itself there is a Built in Torque Limiter. Once the appropriate torque has been reached the slip clutch mechanism will be activated ensuring that the operator cannot over-tighten the fingers and damage the core.

Overview

- Standard Core sizes catered for 70/76/152mm or 3 and 6 inches
- Geared Rotation
- Manual Core Gripping with 8NM Torque unit as standard
- Standard Spindle length 330mm / 13inches or 430mm / 17inches

All of the Packline Attachments are interchangeable. If you have the base stacker truck you can use it for more than one task by swapping over attachments simply and without the need for tools.

Heavy Duty Designs and Variation Available - see page 10



Technical Data

Lifting Capacity
200 kg / 440 lbs

76mm / 3inch Cores
152mm / 6 inch Cores
70mm Cores

Various Diameters and
Widths Catered for

Mechanical Geared
Rotation



Contact Us

01202 307700
01202 722066

info@packline.co.uk
www.packline.co.uk

Clamp Attachment

Used to grip loads by the diameter or circumference such as reels and rotating to any position through 360 degrees as required.

This attachment is used most frequently when reels of material are delivered to site stood vertically, or chimney stacked, on a pallet and need to be rotated into the horizontal to load into a machine that has a removable mandrel.

The mandrel can then be inserted into the core of the reel when horizontal and loaded on to the machine.

As standard, there are five designs of clamp covering the following diameter ranges. If your reels sit outside these ranges we can build a system to suit.

Most reel sizes can be catered for, please provide Packline with the details so that we can assess which model to offer.

To ensure that a suitable gripping force is created on the diameter itself, there is a Built-in Torque Limiter. Once the appropriate torque has been reached when turning the clamping hand wheel, the slip clutch mechanism will be activated ensuring that the operator cannot over-tighten the rollers and damage the reel.

Overview

- Standard diameter ranges
- 200mm to 350mm / 7.5inches to 13.5inches
- 350mm to 520mm / 13.5inches to 20.5inches
- 200mm to 550mm / 7.5inches to 21.5inches
- 250mm to 650mm / 9.5inches to 25.5inches
- 450mm to 850mm / 17.5inches to 33.5inches
- Standard Roller Length 235mm / 9inches
- Manual, Geared Rotation or Motorised Rotation
- Manual or Motorised Clamping

All of the Packline Attachments are interchangeable. If you have the base stacker truck you can use it for more than one task by swapping attachments simply and without the need for tools.

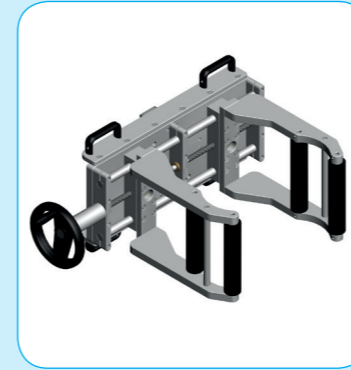

Technical Data

Lifting Capacity
230 kg / 500 lbs

Diameters
200mm to 850mm
7.5inches to 33 inches
Depending on Design

Minimum Width
235mm / 9 inches



Contact Us

01202 307700
01202 722066

info@packline.co.uk
www.packline.co.uk

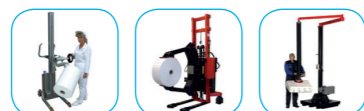

Forward Tipping Clamp Attachment

Used to grip loads by the diameter or circumference such as reels, drums or barrels and rotating forward to any position through 360 degrees as required.

This attachment is used most frequently when reels or drums are delivered to site stood vertically, or chimney stacked, on a pallet and need to be rotated forwards into the horizontal to load into a machine that has a fixed mandrel or to pour the contents into a hopper or receptacle.

If required you can also incorporate sideways rotation as well. This can be simply a manual operation, geared for better control or motorised as required.

Most reel or drum sizes can be catered for, please provide Packline with the details so that we can assess which model to offer.

To ensure that a suitable gripping force is created on the diameter itself there is a Built in Torque Limiter. Once the appropriate torque has been reached when turning the clamping hand wheel, the slip clutch mechanism will be activated ensuring that the operator cannot over-tighten the rollers and damage the reel.

Overview

- Manual, Geared Rotation or Motorised Rotation
- Manual or Motorised Clamping
- Clamping pads designed to suit

All of the Packline Attachments are interchangeable. If you have the base stacker truck you can use it for more than one task by swapping attachments simply and without the need for tools.

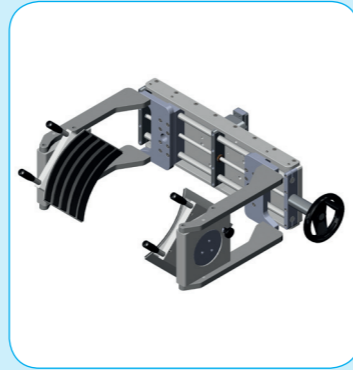

Technical Data

Lifting Capacity
200 kg / 440 lbs

Diameters
200mm to 850mm
7.5inches to 33 inches
Depending on Design

Minimum Width
235mm / 9 inches



Contact Us

01202 307700
01202 722066

info@packline.co.uk
www.packline.co.uk

Drum Clamp Attachment

Used to grip loads by the diameter or circumference such as drums or barrels and rotating to any position through 360 degrees as required.

This attachment is used most frequently when drums are stood vertically and need to be rotated to pour the contents into another drum, receptacle or hopper.

The rotation of the drum may take place manually or using a worm and wheel gearbox. The geared rotation creates a controlled operation for the operator. The worm and wheel gearbox is self-locking and so the load can be held in any position required through 360 degrees.

Most drum sizes can be catered for, please provide Packline with the details so that we can assess which model to offer.

To ensure that a suitable gripping force is created on the diameter itself, there is a Built-in Torque Limiter. Once the appropriate torque has been reached when turning the clamping hand wheel, the slip clutch mechanism will be activated ensuring that the operator cannot over-tighten the pads and damage the drum.

Overview

- Standard drum sizes catered for are 350mm to 650mm / 13.7inches to 25.5inches
- Minimum drum height 280mm / 11 inches Manual, Geared Rotation or Motorised Rotation
- Manual or Motorised Clamping

All of the Packline Attachments are interchangeable. If you have the base stacker truck you can use it for more than one task by swapping attachments simply and without the need for tools.

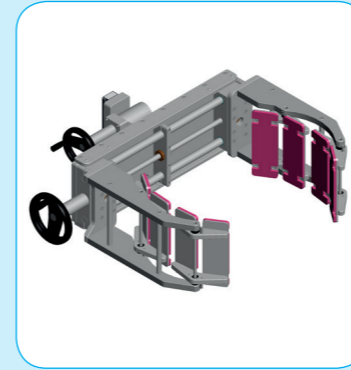

Technical Data

Lifting Capacity
200 kg / 440 lbs

Diameters
350mm to 650mm
14 inches to 22.5 inches
Depending on Design

Minimum Height
280mm / 11 inches



Contact Us

01202 307700
01202 722066

info@packline.co.uk
www.packline.co.uk



Vertical Spindle Attachment Heavy Duty and Variations up to 250 kg / 550 lbs

Used to lift and rotate reels of material by gripping the reel's core the Vertical Spindle is available in a wide range of sizes and configurations.

This attachment is used most frequently when reels of material are delivered to site stood vertically, or chimney stacked, on a pallet and need to be rotated into the horizontal to load into a machine.

As standard, a large majority of reels come with core sizes at either 76 or 152mm. This is the equivalent of 3 or 6 inches. If your reels sit outside these core sizes we can build a system to suit.

Most reel sizes can be catered for, please provide Packline with the details so that we can assess which model to offer.

Overview

- Standard Core sizes catered for 70/76/152mm or 3 and 6 inches
- Up to 250Kg / 550 lbs
- Manual, Geared or Motorised Rotation
- Manual or Motorised Gripping
- Extended Reach for Larger Diameters
- Extended Spindles for Wider Reels
- Manual or Motorised Ejection
- Fully Stainless Steel solutions

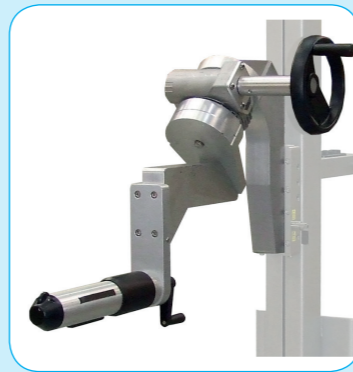

Single Spindle Attachment

The Single Spindle Attachments have been designed to provide a simple means of lifting and transporting reels using the reel's core for support.

This attachment is used most frequently when reels are delivered or stored horizontally and require lifting to height to load on to a machine line.

It may be that the operator either needs to lower the reel on to support rollers or push the reel from the Single Spindle Attachment on to another fixed mandrel on the line. Either way this is a simple solution to handle reels.

By adding the Die Block and using chains the Single Spindle Attachment can also double up as a useful aid in removing tooling from the production line.

Various lengths of spindle are available.

Constructed from stainless steel and coupled with the Compac stacker truck the attachment is suitable for food and pharmaceutical applications.

Overview

- Used to lift loads in the horizontal only
- Spindle Diameter 63.5mm / 2.5inches
- Lengths to suit
- Can add Die Block for tool handling if required

All of the Packline Attachments are interchangeable. If you have the base stacker truck you can use it for more than one task by swapping attachments simply and without the need for tools.

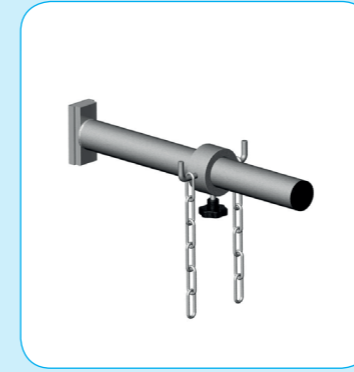

Technical Data

Lifting Capacity
200 kg / 440 lbs

Tube Diameter
63.5mm / 2.5inches

Lengths to Suit



Contact Us

01202 307700
01202 722066

info@packline.co.uk
www.packline.co.uk

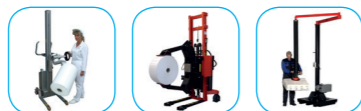

Clamp Attachment Heavy Duty and Variations up to 300 kg / 660 lbs

Used to grip loads by the diameter or circumference such as reels, drums or barrels and rotating forward to any position through 360 degrees as required.

This attachment is used most frequently when reels or drums are delivered to site stood vertically, or chimney stacked, on a pallet and need to be rotated forwards into the horizontal to load into a machine that has a fixed mandrel or to pour the contents into a hopper or receptacle.

Most cylindrical items can be catered for, please provide Packline with the details so that we can assess which model to offer.

Overview

- 100mm to 850mm Diameters
- Lifting Capacities 250 kg / 550 lbs
- Manual, Geared or Motorised Rotation
- Manual or Motorised Clamping
- Fully Stainless Steel solutions
- Removable Pads
- Square Pads
- 'V' Shaped Pads
- Low Profile Pads
- Hook support
- Chutes

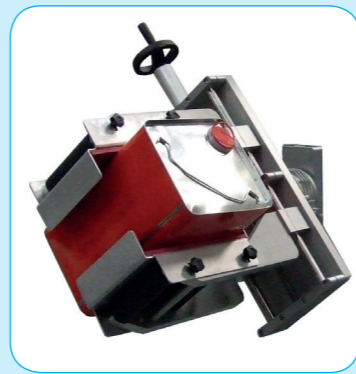
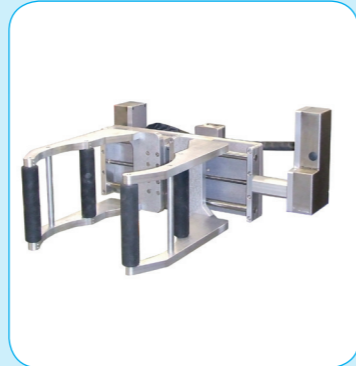
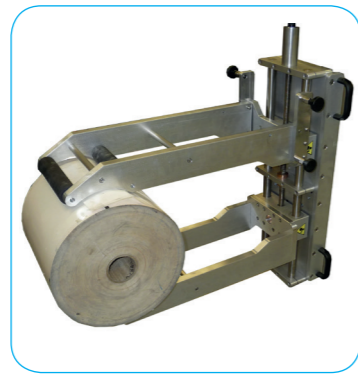

Platform Attachment

The Platform Attachments are suitable for lifting and positioning loads such as reels, drums, components, boxes, containers, tooling, or assemblies.

Applications include work positioning on assembly line and work areas.

Sliding items from shelving and taking to another area or work bench.

Supporting sacks whilst they are opened for the contents to be released into a hopper.

Any item can be handled.

Constructed from stainless steel and coupled with the Compac stacker truck the attachment is suitable for food and pharmaceutical applications.

Variations on the design can also be supplied with different shapes, sizes and styles of platform as required.

Overview

- Able to handle any items that require lifting from one area to another
- Simply slide your item on to the platform
- With the Compac Lifter you can then raise and lower the load electrically to eliminate the need for manual handling

All of the Packline Attachments are interchangeable. If you have the base stacker truck you can use it for more than one task by swapping attachments simply and without the need for tools.

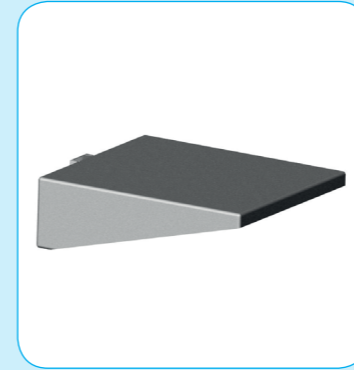

Technical Data

Lifting Capacity
50 kg / 110 lbs

Heavy Duty Designs
Available

Standard Size
400mm x 450mm
15.5inches / 17.5inches

Alternative sizes available



Contact Us

01202 307700
01202 722066

info@packline.co.uk
www.packline.co.uk



Twin Spindle Attachment

The Twin Spindle Attachments have been designed to provide a simple means of lifting and transporting reels by the reel's diameter.

This attachment is used most frequently when reels are delivered or stored horizontally and require lifting to height to load on to a machine where there is a fixed mandrel.

There needs to be room under the line for the lifter's legs to access allowing the reel to be loaded directly on to the mandrel without any need for the operator to push the reel off of the attachment.

Various lengths of spindle are available.

Most reel sizes can be catered for, please provide Packline with the details so that we can assess which model to offer.

Constructed from stainless steel and coupled with the Compac stacker truck the attachment is suitable for food and pharmaceutical applications.

Variations on the design can also be supplied with different diameter spindles or box section for square/ rectangular spindles if required.

Overview

- Used to lift loads in the horizontal only
- Spindle Diameter 63.5mm / 2.5inches
- Lengths to suit
- Varying back plate width available to handle different reel diameters

All of the Packline Attachments are interchangeable. If you have the base stacker truck you can use it for more than one task by swapping attachments simply and without the need for tools.

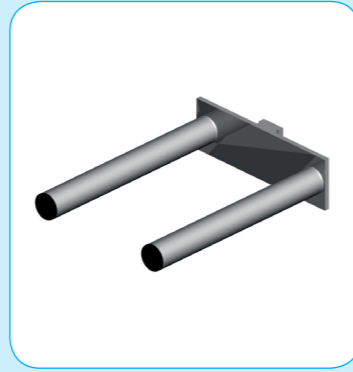

Technical Data

Lifting Capacity
125 kg / 275 lbs

Diameters
200mm to 500mm
7.5inches to 19.5 inches
Depending on Design

Lengths to Suit



Contact Us

01202 307700
01202 722066

info@packline.co.uk
www.packline.co.uk

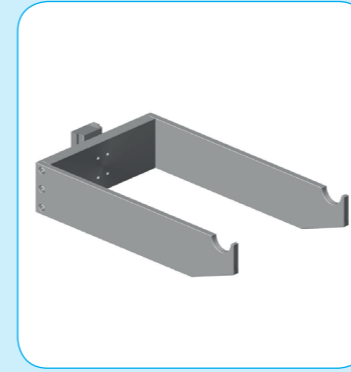

Technical Data

Lifting Capacity
75 kg / 110 lbs

Heavy Duty Designs
Available

Reel Diameters as Standard
up to 900mm / 35.5inches

Widths to suit



Contact Us

01202 307700
01202 722066

info@packline.co.uk
www.packline.co.uk

Cradle Attachment

The Cradle Attachments have been designed to lift and transport reels by supporting mandrels positioned through the reel's core.

This attachment is used most frequently when reels are delivered or stored horizontally and require lifting to a given height to load on to a machine once their mandrel has been fitted through the core.

Variations on the design can also be supplied with different shapes, sizes and styles of cradle arms as required

Most reel sizes can be catered for, please provide Packline with the details so that we can assess which model to offer.

Constructed from anodised aluminium and coupled with the Compac stacker truck the attachment is suitable for food and pharmaceutical applications.

Overview

- Handling reels with their mandrels through the core
- Reels are in the horizontal
- Various sizes can be catered for

All of the Packline Attachments are interchangeable. If you have the base stacker truck you can use it for more than one task by swapping attachments simply and without the need for tools.

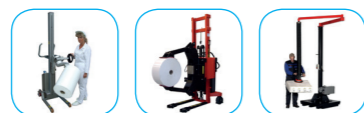

Rotating Tray Attachment

The Rotating Tray Attachments have been designed to provide a simple means of supporting loads and allowing them to rotate in the horizontal plane through 360 degrees.

Loads such as reels, drums and sacks are most commonly handled with this type of attachment.

Stop pins and index plungers can be included in the design if specific positions are required for easy loading and unloading.

This attachment is used most frequently when reels are delivered or stored horizontally and require lifting to height to load on to a machine.

By having the reel's core free the operator can either push the reel on to a fixed mandrel or insert a free mandrel through the core before loading on to the line.

Most item sizes can be catered for, please provide Packline with the details so that we can assess which model to offer.

Constructed from anodised aluminium and stainless steel, coupled with the Compac stacker truck the attachment is suitable for food and pharmaceutical applications.

Overview

- Can handle various items
- The tray rotates by 350 degrees in the horizontal plane
- Can have stop pins or index plungers incorporated into the design if required

All of the Packline Attachments are interchangeable. If you have the base stacker truck you can use it for more than one task by swapping attachments simply and without the need for tools.

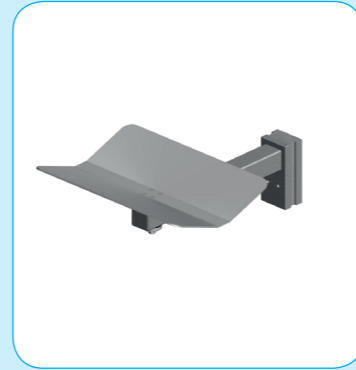

Technical Data

Heavy Duty Tray
215 kg / 473 lbs Capacity
Tray Length 500mm / 19.5inches

Standard Duty Tray
75kg / 165lbs Capacity
Tray Length 350mm / 13.5inches



Contact Us

01202 307700
01202 722066

info@packline.co.uk
www.packline.co.uk



Lifting Frame Attachment

The Packline lifting frame is designed to handle reels of film and material. It is designed so that the frame is opened and the reel is safe to manoeuvre to the required destination for unloading.

This popular solution is simple to use, turning what is often a two man operation into a one man job that is safe and efficient reducing crucial downtime to your production.

Most item sizes can be catered for, please provide Packline with the details so that we can assess which model to offer.

Constructed from anodised aluminium and stainless steel, coupled with the Compac stacker truck the attachment is suitable for food and pharmaceutical applications.

Overview

- Maximum Capacity = 65kg up to 250kg
- Load Centre = 604mm from column (for this particular design)
- Attachment mass = 24kg
- Main Materials = Stainless Steel 304, Aluminium 6082T6, Delrin

All of the Packline Attachments are interchangeable. If you have the base stacker truck you can use it for more than one task by swapping attachments simply and without the need for tools.

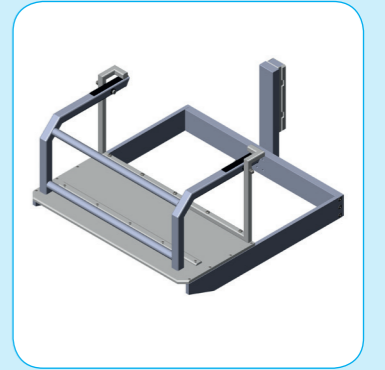

Technical Data

Lifting Capacity
65 kg upto 250kg

Load Centre = 604mm from column (for this particular design)

Attachment mass = 24kg

Main Materials = Stainless Steel 304, Aluminium 6082T6, Delrin



Contact Us

01202 307700
01202 722066

info@packline.co.uk
www.packline.co.uk







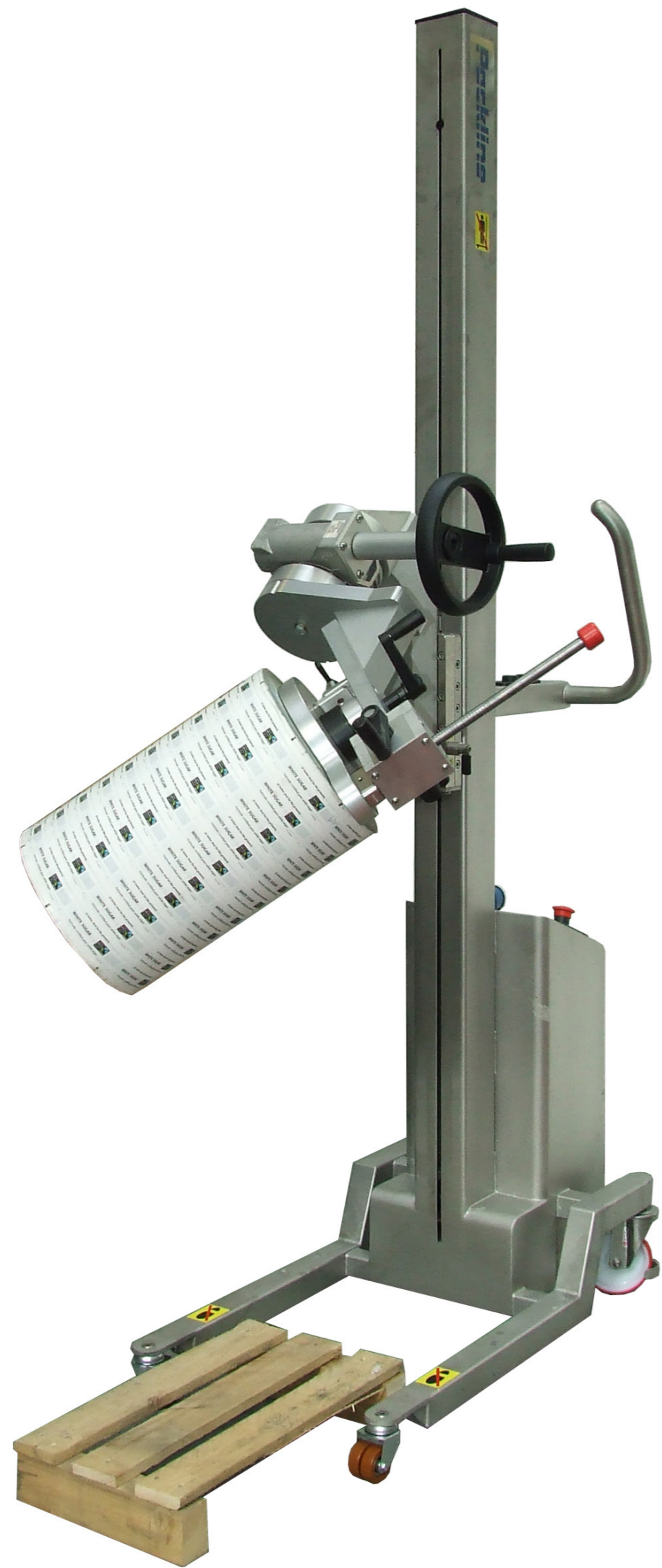



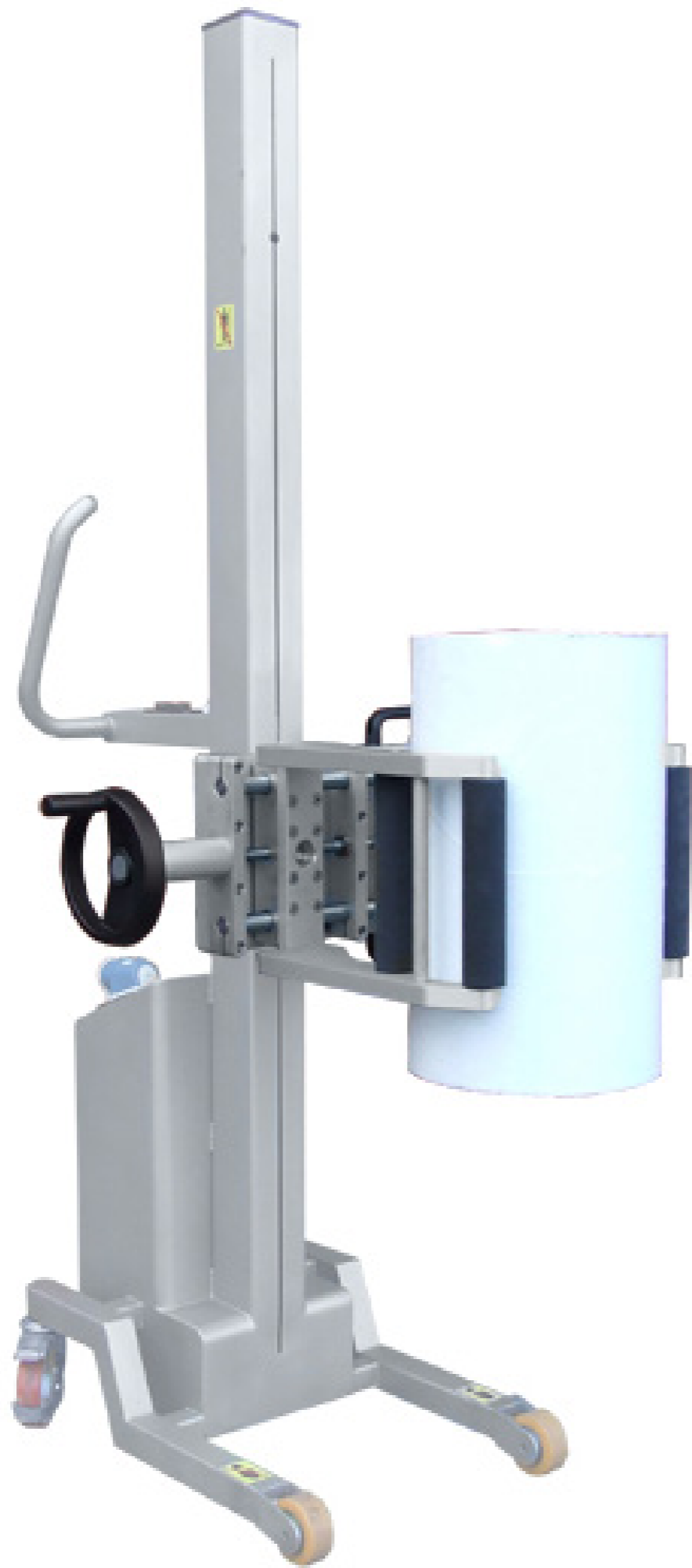

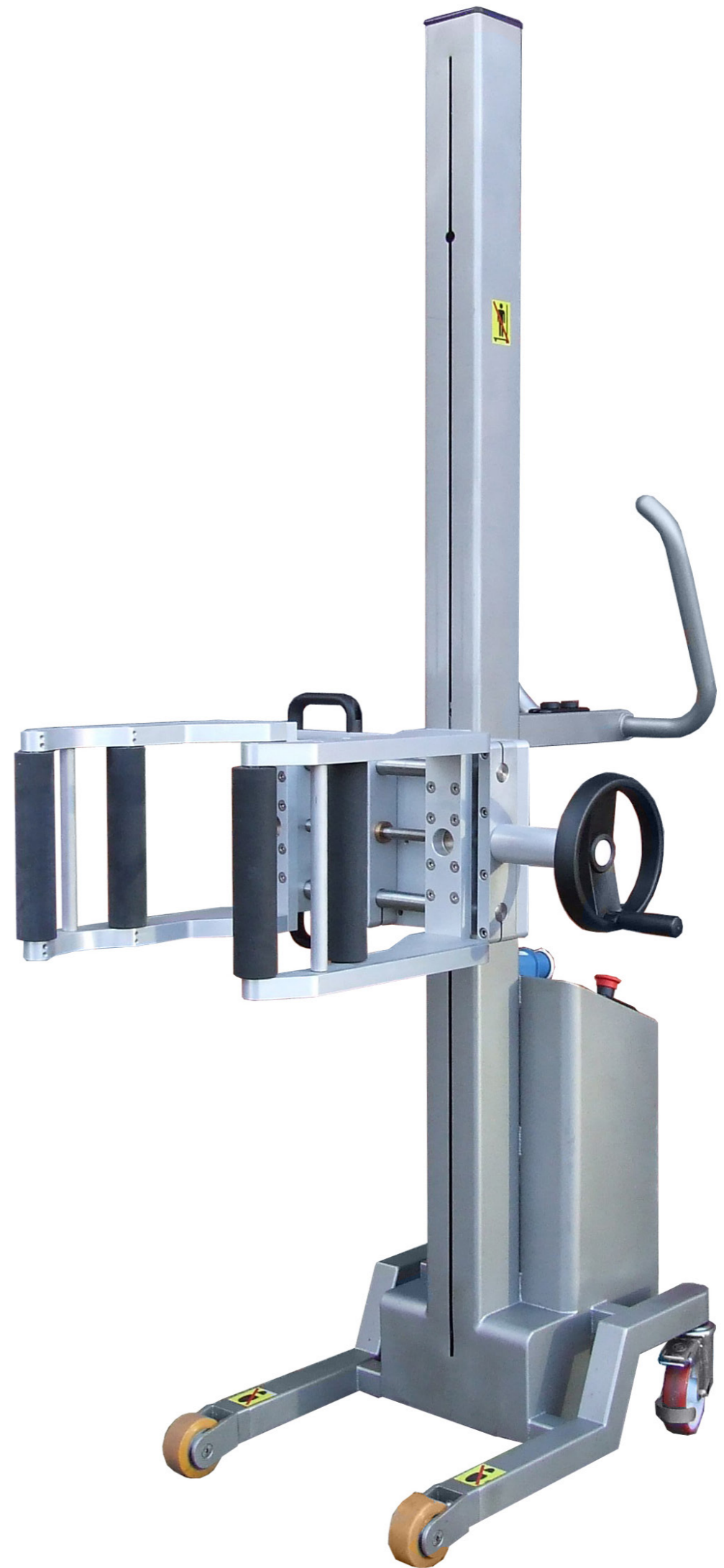













ail
mail

UK

Packline Materials Handling
Manufacture & Design of Lifting and Handling Solutions Worldwide

01202 307700
packline.co.uk

Packline
Materials Handling

Packline
Materials Handling

28

27



Packline Limited
Unit 28 Newtown Business Park
Poole
Dorset
UK
BH12 3LL

T: +44 (0) 1202 307700
F: +44 (0) 1202 722066
E: info@packline.co.uk
W: www.packline.co.uk

