

RWM 60 Heavy Duty Baler

You don't need a gigantic machine to tackle those difficult recyclables. This compact yet heavy duty RWM 60 HD can handle even the toughest of materials, including paint tins, catering cans, plastic bottles and more. Users of this robust baler can therefore benefit from waste volume reduction, site space savings, environmental efficiencies and even the generation of an additional revenue yield – all with this neat little machine!

RWM 60 HD baling press

- ✓ 12 months parts & labour warranty
- ✓ Compact design – ideal for even the most space-constrained locations
- ✓ Impressive press force capable of tackling an array of tough recyclables
- ✓ Produces bales of up to 25kg – up to 1500 drinks cans for instance!
- ✓ Convenient top-loaded feed aperture to prevent material fall out
- ✓ Multi-strapping tying system for a secure hold
- ✓ Fully-automated bale ejection for operational simplicity
- ✓ CE certified
- ✓ Can be sited indoors or outdoors
- ✓ Used by retailers, printers, homeware shops, hotels, restaurants, garden centres and organisations within industry/production, to name just a few
- ✓ Available to buy or rent.



RWM 60 Heavy Duty

TECHNICAL SPECIFICATIONS

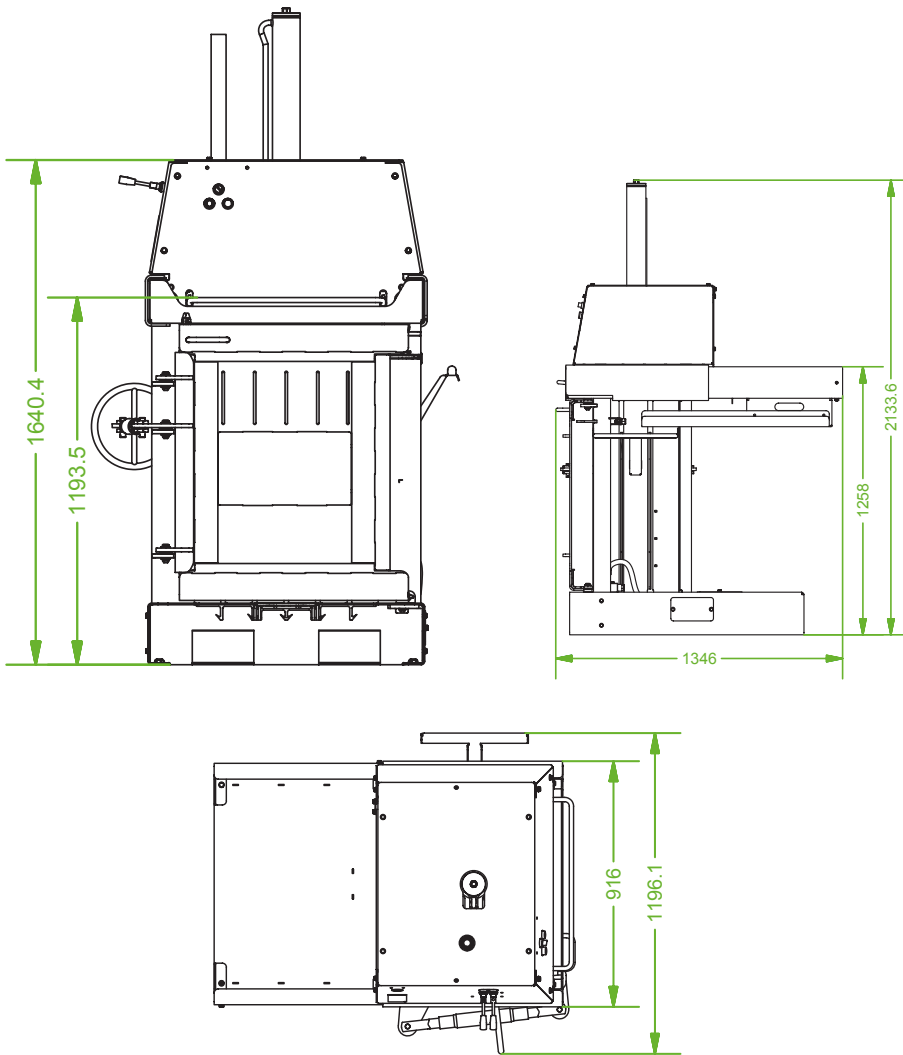

Operating Voltage – 220 - 240v.

Frequency – 50hz.

Connector plug fitted – 16amp single phase, three pin plug

MCB (Miniature circuit breaker) if fitted – Cat C or above.

Riverside Waste Machinery Ltd

Unit A, 2 Jubilee Court, Wath Lane, Copgrove, Harrogate, North Yorkshire HG3 3TB

T 01423 325 038

F 01423 340 788

W www.wastemachinery.co.uk

E sales@wastemachinery.co.uk

Telephone 01423 325 038

Press Force	13 tonnes
Loading Aperture (H x W x D)	890 x 600 x 400mm
Bale Weight	Up to 25kg
Bale Dimensions (H x W x D)	650 x 600 x 400mm
Cycle Time	24 seconds
Noise	75 decibels
Machine weight	706kg
Power Supply (kW-V-Hz)	16amp single phase 2.2kW 220-240V – 50Hz
Overall Dimensions (H x W x D)	2144 x 1267 x 1346mm