

RWM 60 Baling Press

Take control and convert your dry recyclable packing waste into manageable bales. Recyclers and industrial users of a Riverside vertical baler benefit from waste volume reduction; storage, handling and transportation savings; avoidance of ever-increasing landfill charges; the satisfaction of environmental benefits and even possibly the generation of an additional revenue yield.

RWM 60 Baling Press

- ✓ 12 month warranty
- ✓ Compact design makes this machine ideal for locations where space is at a premium e.g retail outlets, offices, pubs, restaurants, fast food outlets and garage forecourts
- ✓ Suitable for volume reduction of cardboard and plastic
- ✓ Large feed aperture for easy loading
- ✓ Can be sited outside
- ✓ 13amp single phase electrics
- ✓ 3.5 Tonne press force
- ✓ 2 Polyester bale tying for a secure bale
- ✓ Supplied with a free bale trolley
- ✓ Bale weights up to 60kg
- ✓ CE approved
- ✓ Powder coated finish for durability



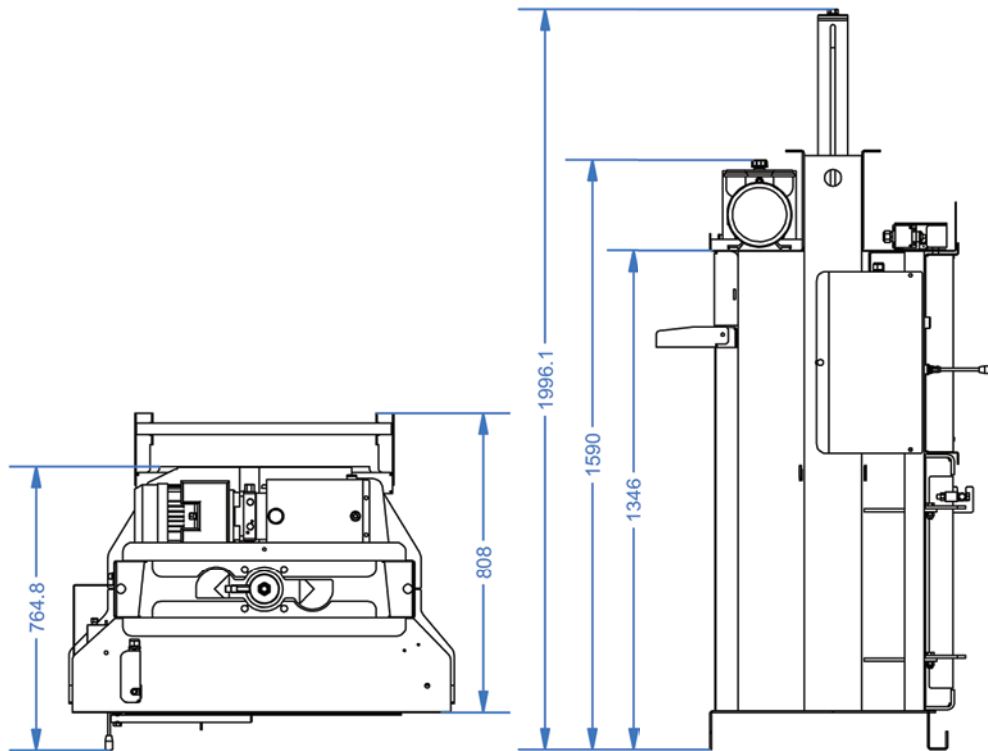

Press Force	3.5 Tonnes
Loading Aperture (H x W x D)	492 x 700 x 500mm
Bale Weight	up to 60 Kg
Bale Dimensions (H x W x D)	800 x 700 x 500mm
Cycle Time	24 seconds
Noise	72 decibels
Machine weight	230 Kg
Power Supply (kW-V-Hz)	13amp 1.5kW-230V-50Hz
Overall Dimensions (H x W x D)	1997 x 1040 x 808mm
Optional Transportation Height	1630mm

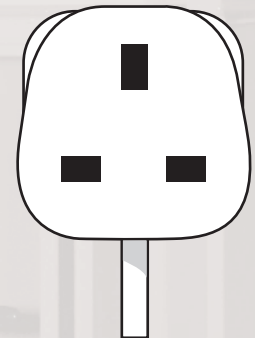

Operating Voltage – 220 - 240v.

Frequency – 50hz.

13amp single phase, standard three pin plug. MCB (Minature circuit breaker) if fitted – Cat C or above.

Riverside Waste Machinery Ltd

Unit A, 2 Jubilee Court, Wath Lane, Copgrove, Harrogate, North Yorkshire HG3 3TB

T 01423 325 038

F 01423 340 788

W www.wastemachinery.co.uk

E sales@wastemachinery.co.uk

Telephone 01423 325 038