

RWM 150 Baling Press

Take control and convert your dry recyclable packing waste into manageable bales. Recyclers and industrial users of a Riverside vertical baler benefit from waste volume reduction; storage, handling and transportation savings; avoidance of ever-increasing landfill charges; the satisfaction of environmental benefits and even possibly the generation of an additional revenue yield.

RWM 150 Baling Press

- ✓ 12 month warranty
- ✓ Suitable for volume reduction of cardboard and plastic
- ✓ 950mm wide feed aperture
- ✓ Can be sited outside
- ✓ Available in 16amp single phase, 3 phase or 110V
- ✓ 8 Tonne press force
- ✓ 3 Polyester bale tying for a secure bale
- ✓ Automatic bale ejection
- ✓ Bale weights up to 150 kg
- ✓ CE approved
- ✓ Fitted retaining claws to prevent material spring back
- ✓ Powder coated finish for durability



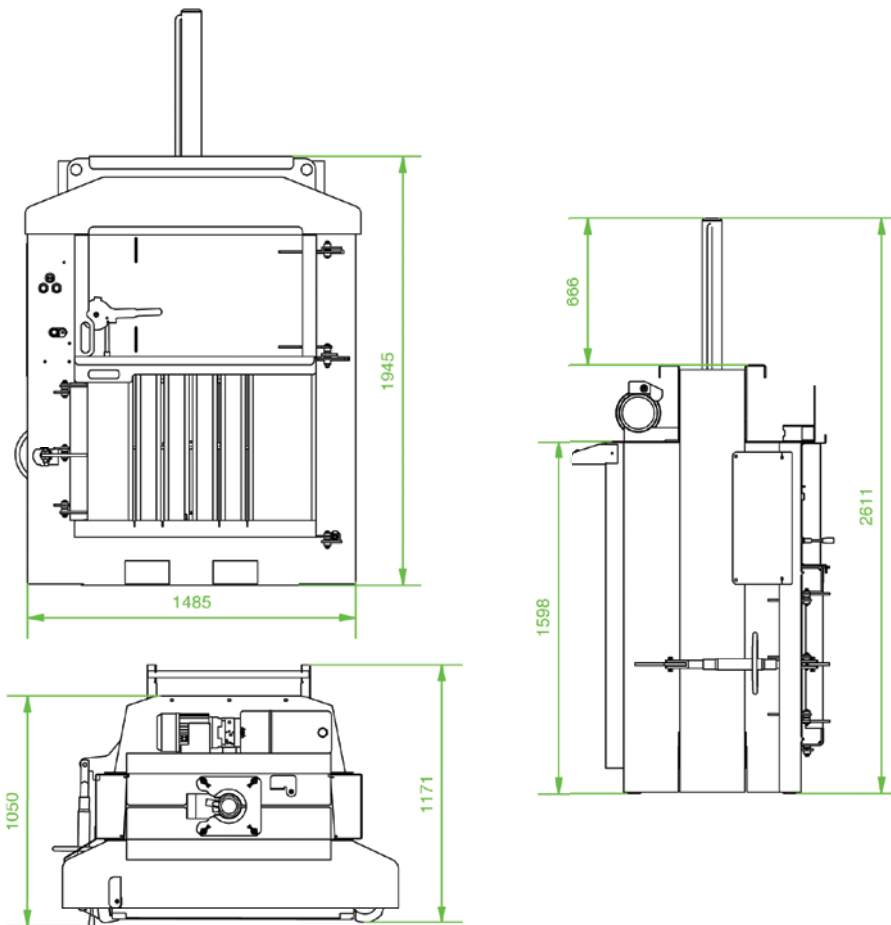

Press Force	8 Tonnes
Loading Aperture (H x W x D)	470 x 975 x 800mm
Bale Weight	up to 150 Kg
Bale Dimensions (H x W x D)	1000 x 975 x 800mm
Cycle Time	40 seconds
Noise	72 decibels
Machine weight	780 Kg
Power Supply (kW-V-Hz)	16 amp 2.2kW-230V-50Hz
Overall Dimensions (H x W x D)	2600 x 1560 x 1200mm
Optional Transportation Height	1955mm

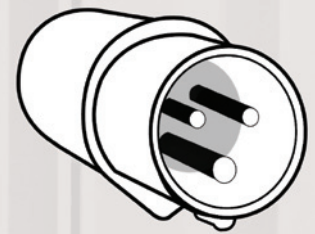

Operating Voltage – 220 - 240v.

Frequency – 50hz.

16amp single phase, three pin plug.

MCB (Minature circuit breaker) if fitted – Cat C or above.