

# RWM 250 Baling Press

Take control and convert your dry recyclable packing waste into manageable bales. Recyclers and industrial users of a Riverside vertical baler benefit from waste volume reduction; storage, handling and transportation savings; avoidance of ever-increasing landfill charges; the satisfaction of environmental benefits and even possibly the generation of an additional revenue yield.

## RWM 250 Baling Press

- ✓ 12 month warranty
- ✓ 1200mm wide feed aperture
- ✓ Can be sited outside
- ✓ Suitable for volume reduction of cardboard and plastic
- ✓ Available in 16 amp single phase, 3 phase or 110V
- ✓ 16 Tonne press force
- ✓ 4 Polyester bale tying for a secure bale
- ✓ Automatic bale ejection
- ✓ Bale weights up to 250kg
- ✓ CE approved
- ✓ Fitted retaining claws to prevent material spring back
- ✓ Powder coated finish for durability



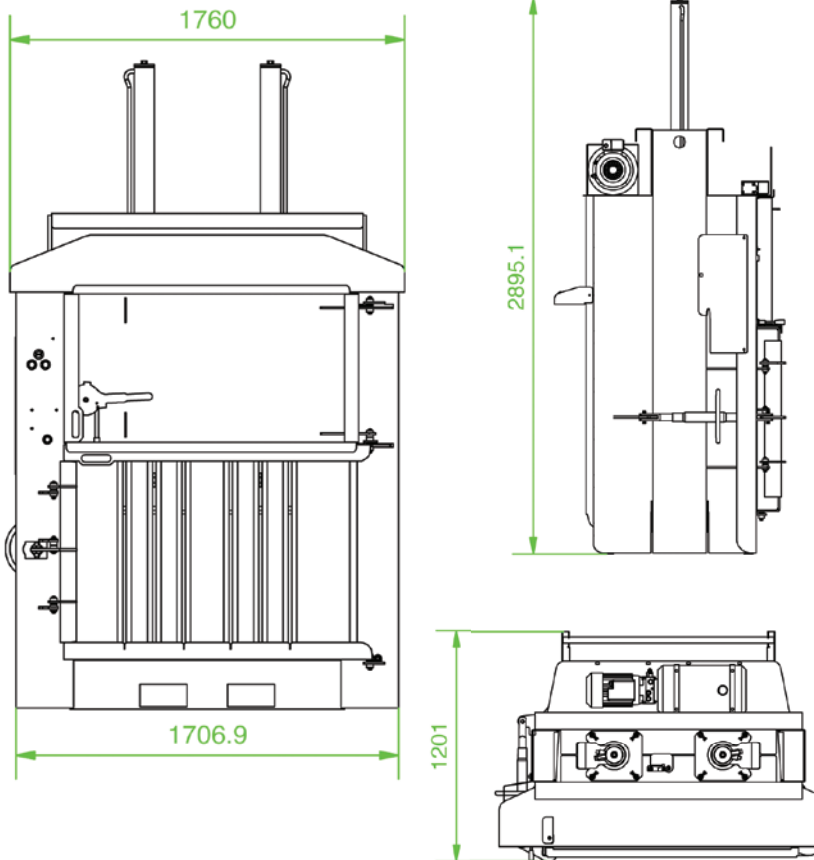

<b>Press Force</b>	16 Tonnes
<b>Loading Aperture (H x W x D)</b>	678 x 1200 x 800mm
<b>Bale Weight</b>	up to 250 Kg
<b>Bale Dimensions (H x W x D)</b>	1000 x 1200 x 800mm
<b>Cycle Time</b>	34 seconds
<b>Noise</b>	74 decibels
<b>Machine weight</b>	985 Kg
<b>Power Supply (kW-V-Hz)</b>	16amp 2.2kW-230V-50Hz
<b>Overall Dimensions (H x W x D)</b>	2900 x 1707 x 1200mm
<b>Optional Transportation Height</b>	2250mm

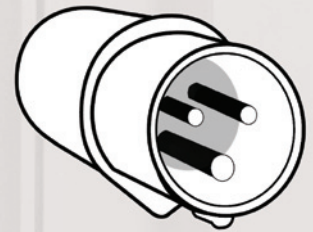

Operating Voltage – 220 - 240v.

Frequency – 50hz.

Connector plug fitted – 16amp single phase, three pin plug.

MCB (Minature circuit breaker) if fitted – Cat C or above.