

RWM 500 Low Height Baler

Organisations of all shapes and sizes are now handling more dry recyclable 'waste' than ever before, which means interest in mill size balers is high. But such balers can often be bulky, which makes the machinery hard to position on size-constrained sites with low ceiling heights. That's why we've introduced the RWM 500 LH (low height) baler, which is perfect for spaces with an elevation less than 2.3m tall. Capable of producing bales of up to 500kg with ease, this is a tidy machine with vast recycling potential.



Key Features:

- ✓ Creates mill size bales with ease
- ✓ Automatic compaction cycle for operational simplicity
- ✓ Automatic bale ejection system
- ✓ Open door bale tie-off
- ✓ Bale full light
- ✓ CE certified
- ✓ Supplied with 12 months parts and labour warranty
- ✓ Full operator training supplied
- ✓ Used by prisons and manufacturers, through to large scale recyclers, skip hire firms, distribution depots and more
- ✓ Available to buy or rent
- ✓ Suitable for indoor or outdoor use



RWM 500 Low Height Baler

TECHNICAL SPECIFICATIONS

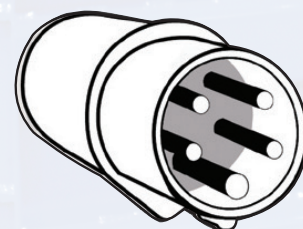
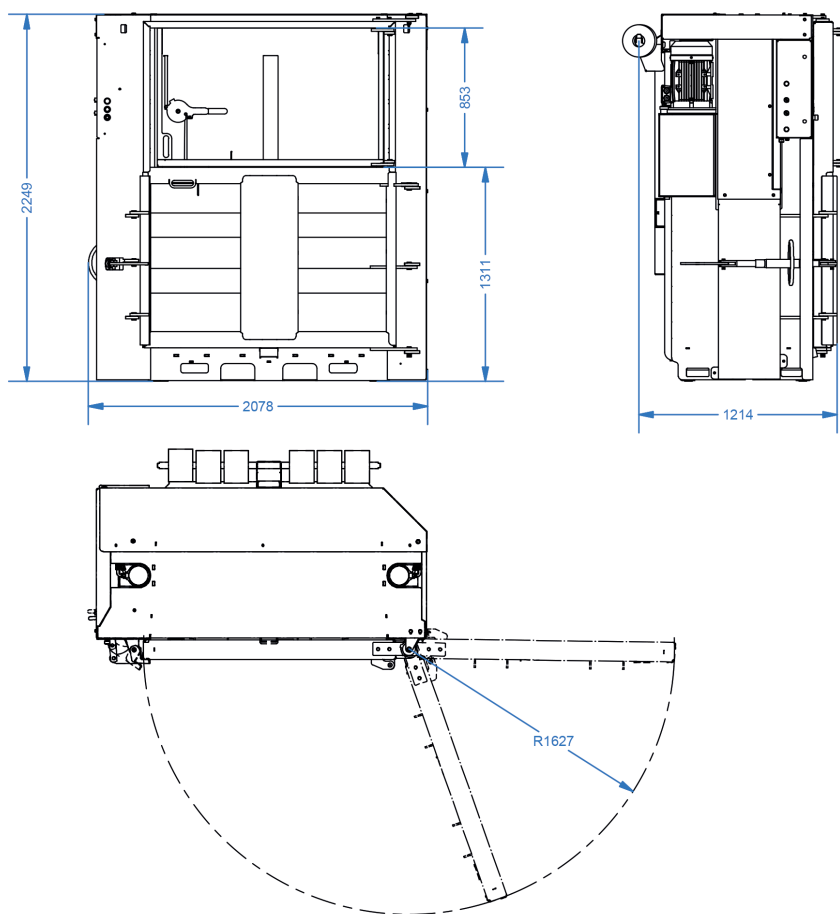

Operating Voltage – 400v.

Frequency – 50hz.

32amp three phase five pin –
A + N + PE

MCB (Miniature circuit breaker)
if fitted – Cat C or above.

Riverside Waste Machinery Ltd

Unit A, 2 Jubilee Court, Wath Lane, Copgrove,
Harrogate, North Yorkshire HG3 3TB

T 01423 325 038

F 01423 329 182

W www.wastemachinery.co.uk

E sales@wastemachinery.co.uk

Telephone 01423 325 038

Press Force

50 tonnes

Loading Aperture (H x W x D)

679 x 1400 x 800mm

Bale Weight

up to 500kg

Bale Dimensions (H x W x D)

1000 x 1400 x 800mm

Cycle Time

35 seconds

Noise

65 decibels

Machine weight

2100kg

Power Supply (kW-V-Hz)

32amp 11kW-400V-50Hz

Overall Dimensions (H x W x D)

2249 x 2041 x 1350mm