

RWM Drum Press

A modern and cost effective way of reducing your waste volumes by up to 90%. Simple to use with clear controls which are suitable for all types and sizes of business.

RWM 205 Drum Press

- ✓ 12 month warranty
- ✓ 24 Tonne press force
- ✓ Suitable for up to 210L barrels
- ✓ 30 litre residual liquid collection tray with tap connection
- ✓ Clear controls for easy operation
- ✓ Totally enclosed shell ensures high level of safety
- ✓ Can be sited outside
- ✓ 32amp 3 phase electrics
- ✓ CE approved
- ✓ Powder coated finish for durability



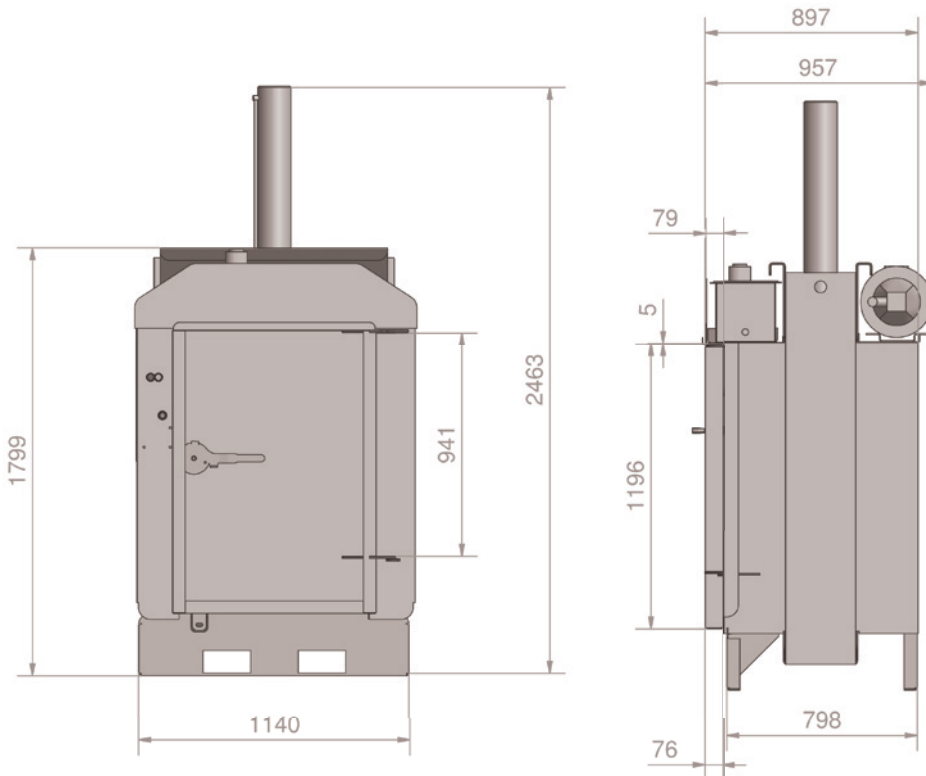

Press Force	24 Tonnes
Cycle Time	40 seconds
Noise	75 decibels
Machine weight	690 Kg
Compaction Ration	10:1
Power Supply (kW-V-Hz)	32amp 3 Phase 11kW-400V-50Hz
Overall Dimensions (H x W x D)	2463 x 1140 x 1000mm
Optional Transportation Height	1800mm

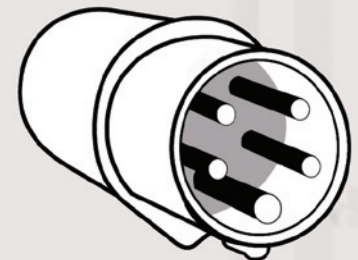

Rated Power - 11kw.

Operating Voltage – 400v.

Frequency – 50hz.

32amp three phase five pin – A + N + PE

MCB (Minature circuit breaker) if fitted – Cat D or above.