

RWM Bin Press

A modern and cost effective way of reducing your waste volumes by up to 90%. Simple to use with clear controls which are suitable for all types and sizes of business.

RWM Bin Press

- ✓ 12 month warranty
- ✓ 3.5 Tonne press force
- ✓ Clear controls for easy operation
- ✓ Can be sited outside
- ✓ A compaction ratio of 3:1 (depending on material used)
- ✓ Reduces weekly waste collections
- ✓ Incorporated bin lifter ensures bin wheels are not damaged during compaction
- ✓ Safe and Easy to use
- ✓ Adaptor available to compact 660 litre bin
- ✓ 13amp single phase electrics
- ✓ CE approved
- ✓ Powder coated finish for durability
- ✓ Two hand operation makes for a safe

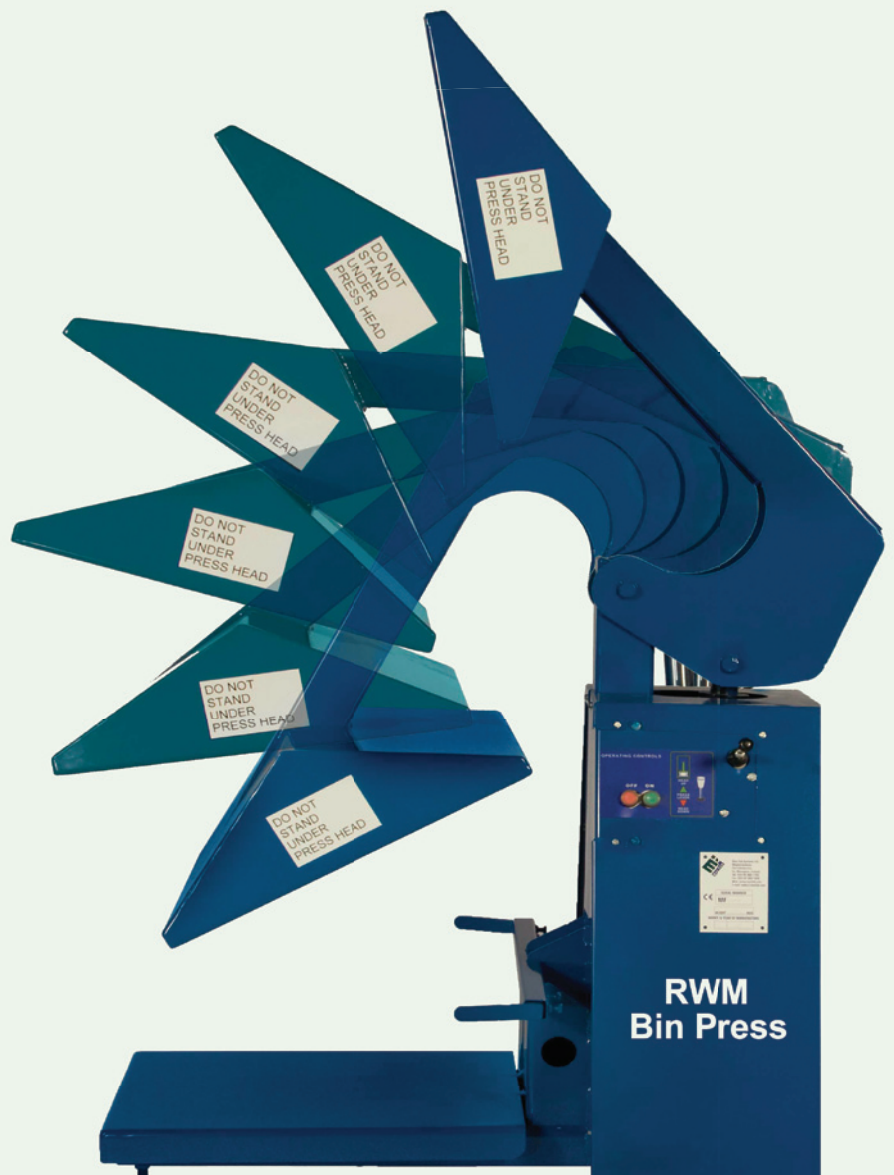

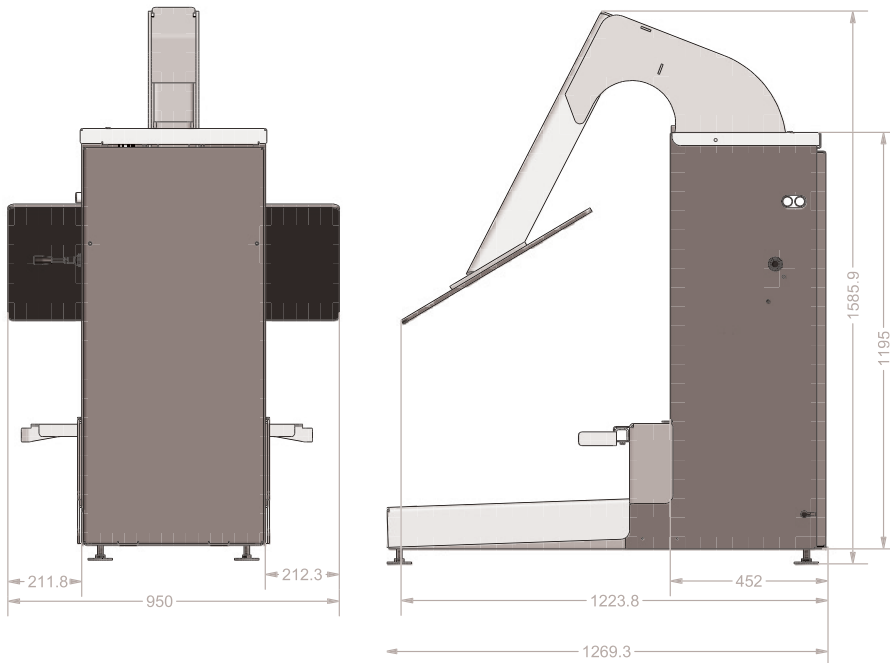

| | |
|---------------------------------------|-----------------------|
| Press Force | 3.5 Tonnes |
| Cycle Time | 20 seconds |
| Noise | 72 decibels |
| Machine weight | 270 Kg |
| Compaction Ratio | 3:1 |
| Power Supply (kW-V-Hz) | 13amp 1.5kW-230V-50Hz |
| Overall Dimensions (H x W x D) | 2120 x 950 x 1270mm |
| Optional Transportation Height | 1650mm |

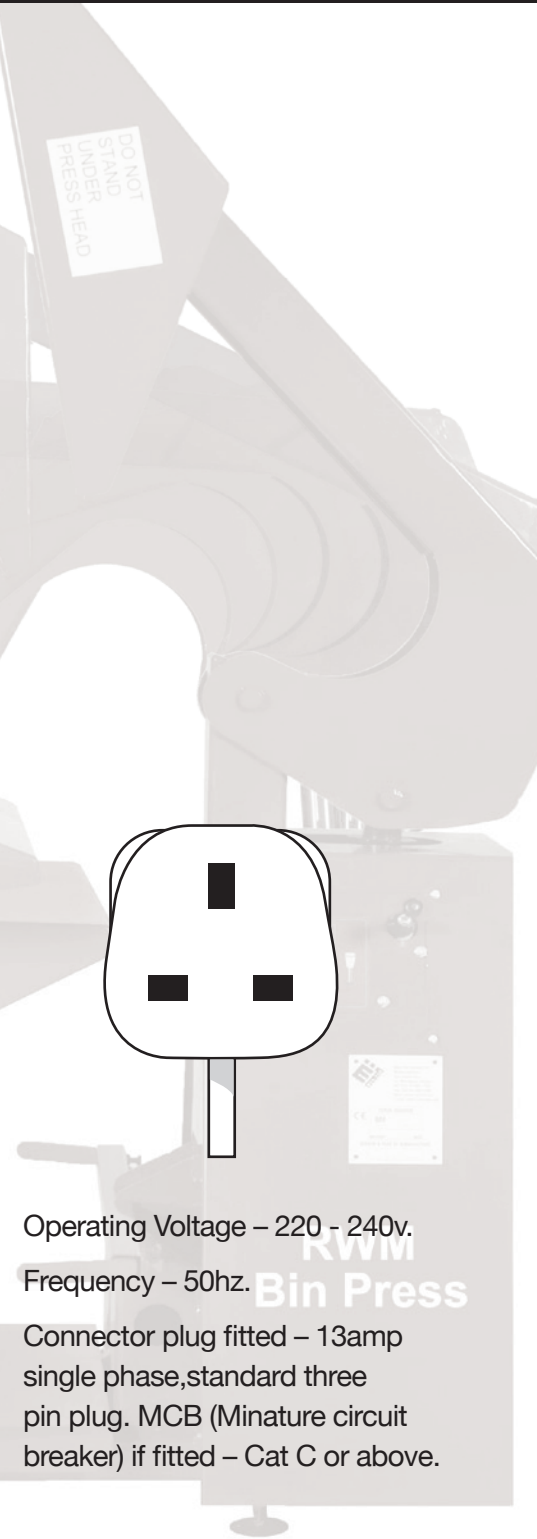

Operating Voltage – 220 - 240v.
 Frequency – 50hz.
 Connector plug fitted – 13amp single phase, standard three pin plug. MCB (Minature circuit breaker) if fitted – Cat C or above.