

# RWM CE2000

Did you know there's more to Riverside than balers? Introducing our industry-leading compactors – increasingly popular waste handling solutions for organisations with larger volumes of general waste or recyclables, who are regularly filling skips with their material arisings.

Highly configurable to suit our customers' individual requirements, the RWM CE2000 is an extremely clever yet compact and easy-to-operate static machine, which typically offers hassle-free 4:1 volume reduction of dry commercial and industrial waste.



**\*Available to hire**

## RWM CE2000

- ✓ Intelligent electronics and hydraulics for high-performance compaction
- ✓ Optimum payloads + less lifts = more savings!
- ✓ 75% and 100% full light for efficient waste collections
- ✓ State-of-the-art data management, e.g. SMS/email alerts – variable filling levels, full and machine fault status
- ✓ Perfect for general dry mixed waste and recyclables
- ✓ Automatic pin off system
- ✓ Twin hydraulic rams and 32 tonne compaction force
- ✓ Low maintenance, by design, with remote diagnostics and proactive machine monitoring
- ✓ CE certified with dual channel safety circuits and emergency stop
- ✓ Energy-efficient power packs for low electricity costs
- ✓ Can be used in isolation or alongside waste baler
- ✓ Optional auxiliary equipment available, e.g. hydraulic bin lifter system with galvanised safety cage.



**Can't find what you're looking for? Our compactor options are almost endless – with various bin lift and hopper configurations, colours and sizes available. We can practically offer bespoke! Contact us to discuss your specific needs.**

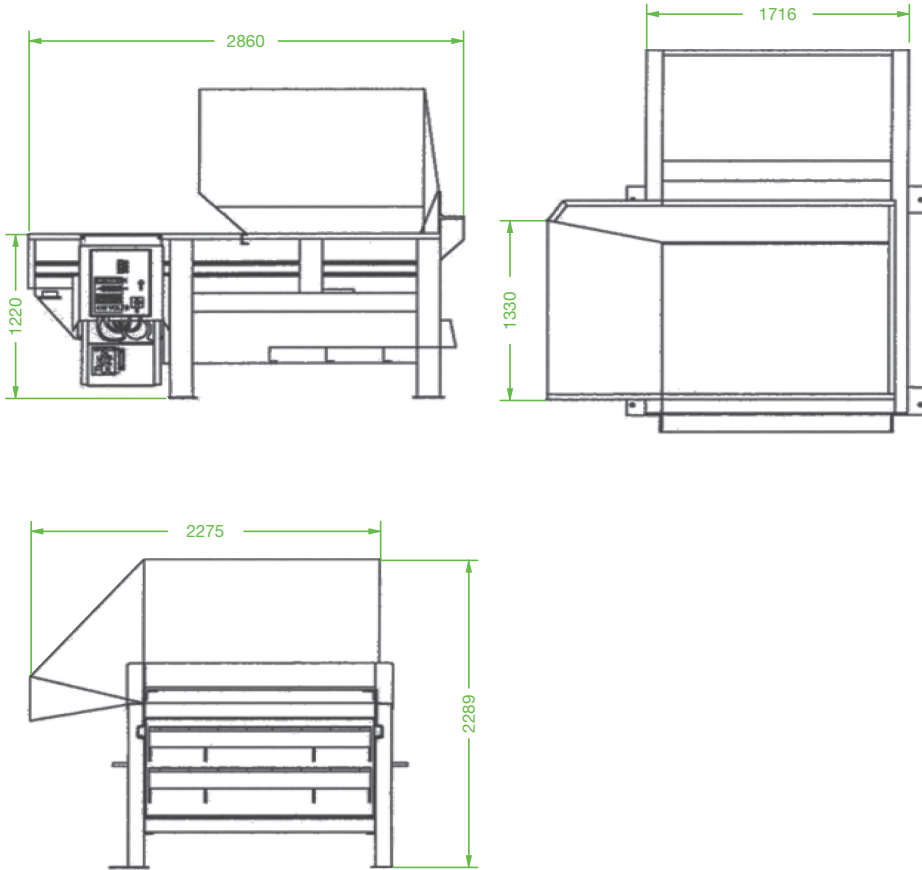

Operating Voltage – 415V  
 24V control circuit  
 20amp three phase – N + PE  
 Type D circuit breaker  
 or motor-rated fuses

<b>Compaction Force</b>	32 tonnes
<b>Loading Aperture</b>	1500 x 1200mm
<b>Loading Height</b>	1225mm
<b>Volume Per Hour</b>	142m <sup>3</sup>
<b>Charge Box Volume</b>	1.5m <sup>3</sup>
<b>Cycle Time</b>	38 seconds
<b>Motor</b>	5.5kW
<b>Ram Stroke</b>	736mm
<b>Blade Penetration</b>	320mm
<b>Overall Dimensions (H x W x L)</b>	2400 x 2035 x 2710mm

### Riverside Waste Machinery Ltd

Unit A, 2 Jubilee Court, Wath Lane, Copgrove,  
 Harrogate, North Yorkshire HG3 3TB

T 01423 325 038

F 01423 340 788

W [www.wastemachinery.co.uk](http://www.wastemachinery.co.uk)

E [sales@wastemachinery.co.uk](mailto:sales@wastemachinery.co.uk)

**Telephone 01423 325 038**