

RWM CE3000

Did you know there's more to Riverside than balers? Introducing our industry-leading compactors – increasingly popular waste handling solutions for organisations with larger volumes of general waste or recyclables, who are regularly filling skips with their material arisings.

Highly configurable to suit our customers' individual requirements, the RWM CE3000 is an extremely clever, neat and simple-to-operate static machine for up to 190m³ of dry mixed waste and recyclables per hour. Typically facilitates 4:1 volume reduction of commercial and industrial waste with ease!



***Available to hire**

RWM CE3000

- ✓ Intelligent electronics and hydraulics for high-performance compaction
- ✓ Optimum payloads + less lifts = more savings!
- ✓ 75% and 100% full light for efficient waste collections
- ✓ State-of-the-art data management, e.g. SMS/email alerts – variable filling levels, full and machine fault status
- ✓ Perfect for general dry mixed waste and recyclables
- ✓ Automatic pin off system
- ✓ Twin hydraulic rams and 32 tonne compaction force
- ✓ Low maintenance, by design, with remote diagnostics and proactive machine monitoring
- ✓ CE certified with dual channel safety circuits and emergency stop
- ✓ Energy-efficient power packs for low electricity costs
- ✓ Can be used in isolation or alongside waste baler
- ✓ Optional auxiliary equipment available, e.g. hydraulic bin lifter system with galvanised safety cage.



Can't find what you're looking for? Our compactor options are almost endless – with various bin lift and hopper configurations, colours and sizes available. We can practically offer bespoke! Contact us to discuss your specific needs.

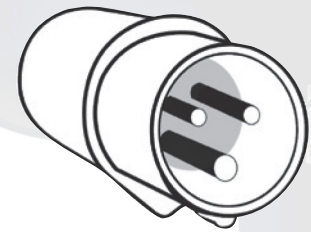
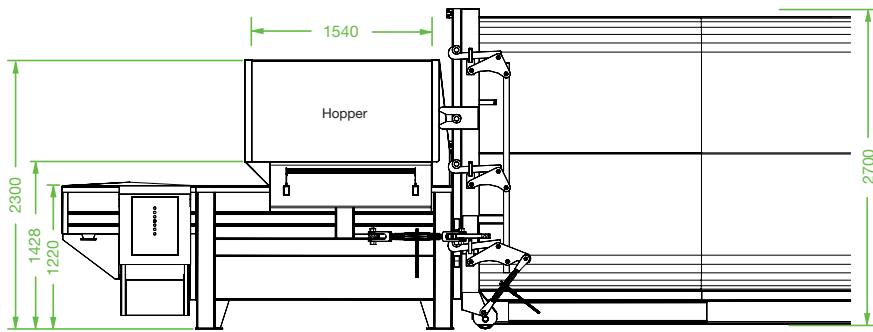
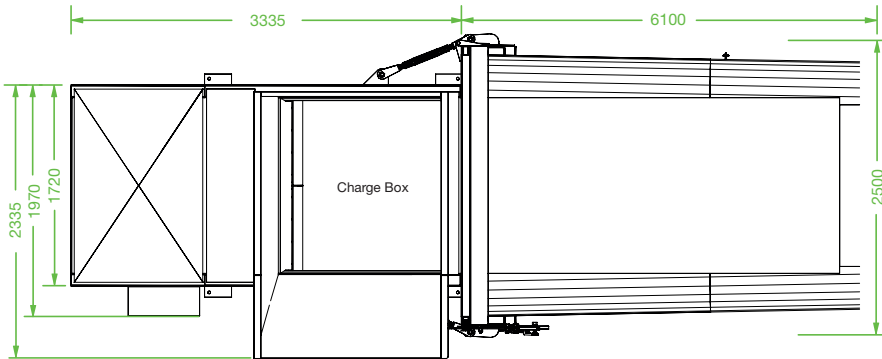

Operating Voltage – 415V
 24V control circuit
 20amp three phase – N + PE
 Type D circuit breaker
 or motor-rated fuses

Compaction Force	32 tonnes
Loading Aperture	1500 x 1500mm
Loading Height	1225mm
Volume Per Hour	190m ³
Charge Box Volume	2.0m ³
Cycle Time	44 seconds
Motor	5.5kW
Ram Stroke	736mm
Blade Penetration	350mm
Overall Dimensions (H x W x L)	2400 x 2035 x 3335mm

Riverside Waste Machinery Ltd

Unit A, 2 Jubilee Court, Wath Lane, Copgrove,
 Harrogate, North Yorkshire HG3 3TB

T 01423 325 038

F 01423 340 788

W www.wastemachinery.co.uk

E sales@wastemachinery.co.uk

Telephone 01423 325 038