

The Hiden ESPion Series

Advanced Langmuir Probes
for Plasma Diagnostics

The Hiden ESPion Series

Advanced Langmuir Probes for Plasma Diagnostics

The Hiden ESPion series are specialised tools for routine analysis of plasma characteristics, giving the user direct measurements for monitoring plasma stability and reproducibility.

Hiden's ESPionSoft software package enables the user to automatically determine a wide variety of plasma parameters in real-time.

A user-friendly interface allows non-expert users to gain valuable data about plasma conditions with a shallow learning curve.

Systems can be configured with a range of customisable options to interface with a wide variety of plasma system arrangements. For example, customised insertion length, z-motion drives, flexible and articulated probes and a range of materials and geometries can be configured to suit application requirements.

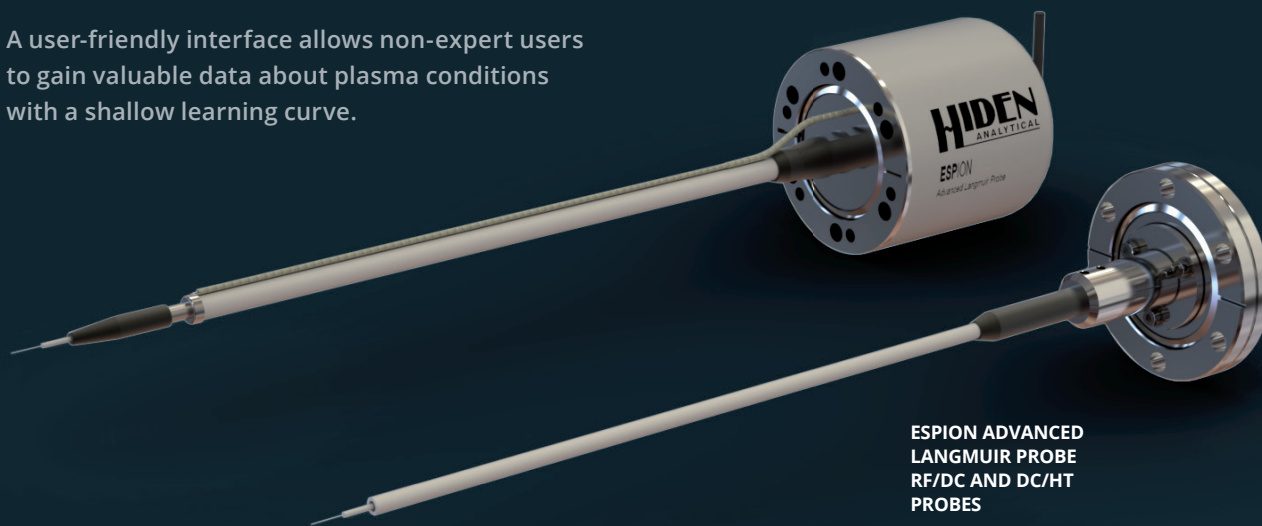

ESPION ADVANCED
LANGMUIR PROBE
RF/DC AND DC/HT
PROBES

Applications:

The Hiden ESPion series are offered with a range of standard plasma sampling options to provide a non-invasive sampling interface for a broad range of plasma applications including:

- ▶ ECR- Electron Cyclotron Resonance
- ▶ HIPIMS
- ▶ DC Magnetron Discharge
- ▶ Helicon Source
- ▶ DC Glow Discharge Plasma
- ▶ Pulsed Plasma & Laser Ablation
- ▶ Parallel Plate - RF Plasma
- ▶ ICP - Inductively Coupled Plasma

Data is gained from the direct measurement of a broad range of plasma parameters such as:

- ▶ Floating Potential, V_f
- ▶ Plasma Potential, V_p .
- ▶ Electron Energy Distribution Function, EEDF
- ▶ Debye length, λ_D
- ▶ Ion Flux, Γ_i
- ▶ Ion density, N_i , and electron density, N_e , over the range 10^{14} - 10^{19} m^{-3}
- ▶ Electron Temperature, T_e , up to 10 eV

A choice of probes are available for RF, DC and high temperature plasmas.

- ▶ RF/DC for RF and DC plasmas
- ▶ DC/HT for DC and high temperature plasmas

ESPion Series Probe Layout

ESPion Series Probe Configuration



CYLINDRICAL PROBE TIP



PLANAR PROBE TIP

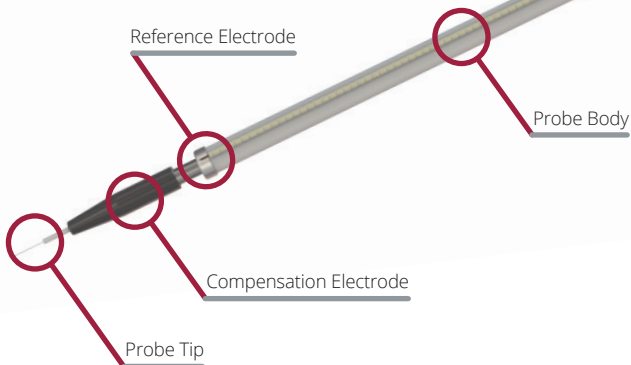
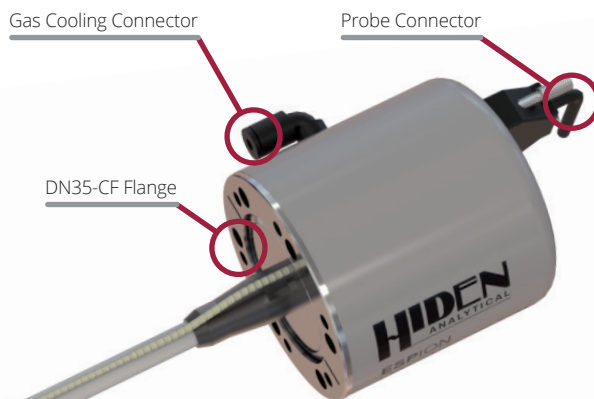

Compensation Electrode

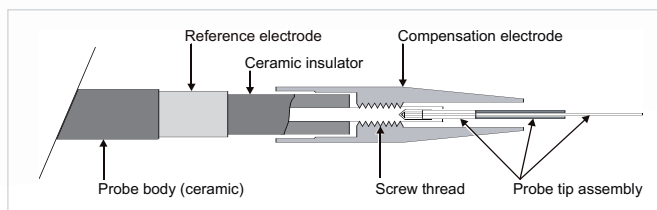

Included in the RF ESPion probe is a wide band compensation electrode, featuring the highest blocking impedance found in any commercially available Langmuir probe. RF distortion at the probe tip is removed by AC de-coupling the probe from the DC current measuring circuit, allowing the probe tip to follow the RF fluctuation and give reliable data.

Probe Tip

User replaceable probe tips are also available in different geometries to suit different plasma applications including:

- ▶ Cylindrical
- ▶ 90° for magnetically confined plasmas and plasma mapping
- ▶ Planar for Hall thruster discharges

More than 20 tip materials are available, including Tungsten, Platinum, Molybdenum and Tantalum. Tips can be automatically cleaned between scans with software-controlled cleaning regimes.

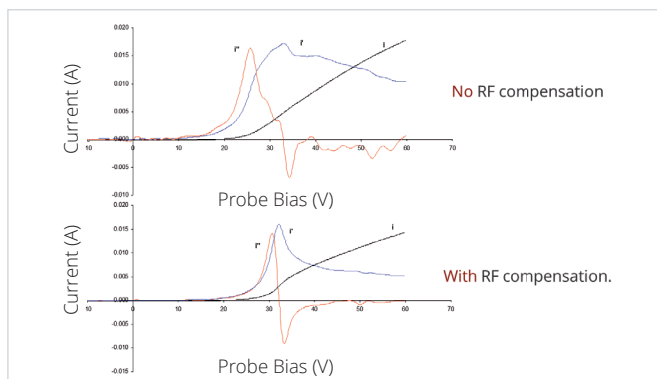

EXAMPLE RF COMPENSATION DATA

Reference Electrode

The integrated low frequency reference electrode provides an internally referenced voltage to compensate for low frequency interference effects. Examples include, shift in plasma potential due to deposition on chamber walls and external power supply noise.

Probe Body

The ESPion probe body is manufactured in alumina and available in a choice of standard lengths to suit chamber mounting and plasma geometries. 316.5 mm insertion length is offered as standard, with options available up to > 1m. Articulated and flexible probes are also available to suit customer requirements.

A variety of probe mounting choices are offered with either Conflat type, KF type or similar vacuum compatible flanges. A DN-35-CF (2¾" OD) Conflat flange is standard.

Gas Cooling

Integral gas cooling of the main body of the probe ensures optimum operation of the high impedance circuit in high temperature environments.



ESPION GAS COOLING CONNECTOR

Z-Motion Drives

A range of bellows-sealed, stepper motor driven 'z'-drives allowing spatially resolved measurements are available. Probe movement is fully software controlled enabling a suite of measurements to be pre-set to define linear motion rate, probe position and measurement period. Manual versions are also available.

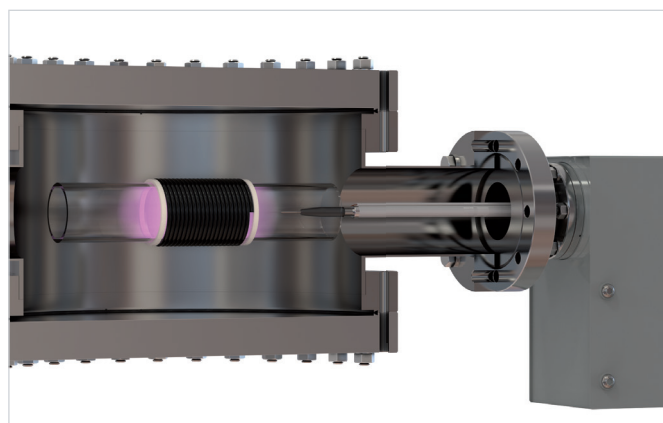

ESPION FITTED TO AUTOMATED Z-DRIVE



ESPION FITTED TO MANUAL Z-MOTION DRIVE

ESPionSoft Software Package

The Hiden ESPionSoft software package allows expert and non-expert users to carry out manual, semi-automatic and fully automatic analyses. The user-friendly interface has the following key features:

- ▶ Specific plasma probe data functions for the extraction of plasma parameters.
- ▶ Multiple graph displays and multiple files open simultaneously.
- ▶ Standard math operations on data curves (add, average, smooth, differentiate).
- ▶ Data curves may be combined mathematically, including a scan averaging feature.
- ▶ Per scan report of calculated plasma parameters including analysis statistics, slopes and intercepts.

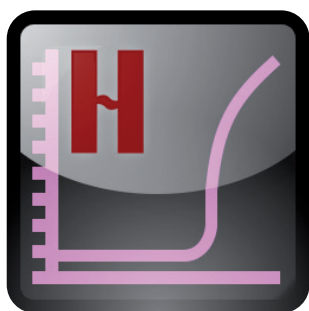

Scan set up is intuitive and uses the “Setup Wizard” where a wide range of experimental parameters can be modified, including:

- ▶ Start / stop potentials
- ▶ Data averaging and scan period
- ▶ Probe tip cleaning
- ▶ Automatic Z-motion steps and range
- ▶ Signal gating delay and increment timers

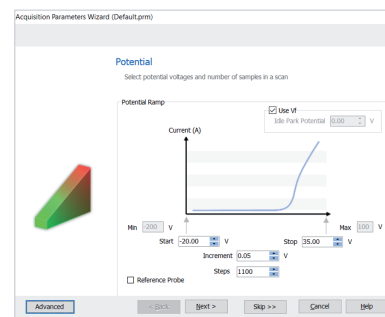
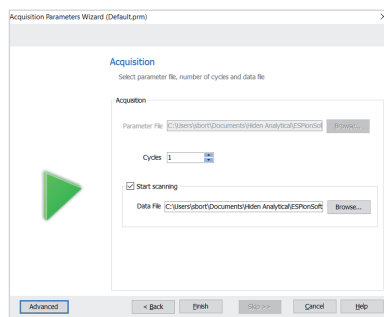

The Acquisition Wizard allows the specific scan parameters to be set, such as the scanned probe voltage, -200 V to +100 V, minimum increment 25 mV and current range, 20 μ A to 1 A.

TIP SELECTION AND AUTOMATIC CLEANING

Parameters for tip geometry can be modified, allowing the use of a range of tip geometries. Tip cleaning potential and time are also adjustable, for intra-scan cleaning.

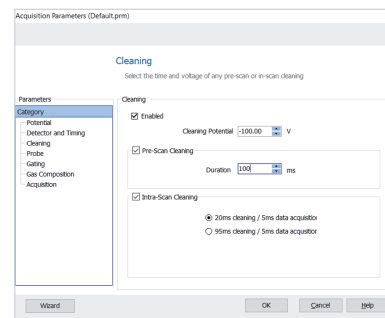
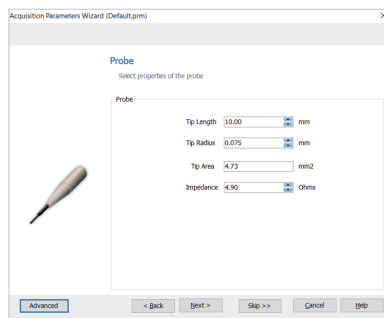

TIME RESOLVED MEASUREMENTS

ESPion systems offer a TTL input that allows measurements to be synchronised with an external TTL signal. Gate width and delay can be set, and the acquisition window can be moved automatically through the pulse to gain time resolved data from pulsed plasmas.

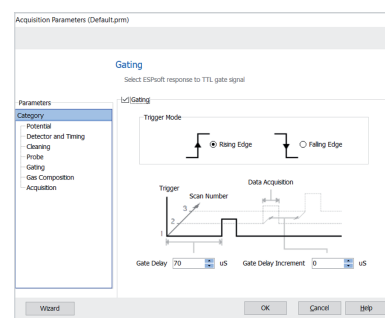

Example Data

Data Analysis

Analysis of plasma parameters can be either fully or semi-automated. Analysis is presented as a report or analysis of individual parameters. Raw data can also be exported in a number of formats for manipulation with external programs such as MS Excel, Origin etc.

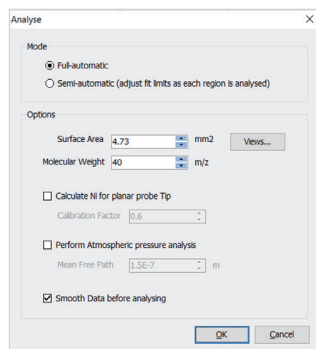

The I-V Curve

Data is presented as an I-V curve, where voltage is scanned and the resulting current drawn from the plasma is plotted. The resulting I-V curve can be used to determine the fundamental plasma parameters such as:

- ▶ Floating Potential, V_f
- ▶ Plasma Potential, V_p
- ▶ Electron Energy Distribution Function, EEDF
- ▶ Debye length, λ_D
- ▶ Ion Flux, Γ_i
- ▶ Ion density, N_i , and electron density, N_e , over the range 10^{14} - 10^{19} m^{-3}
- ▶ Electron Temperature, T_e , up to 10 eV

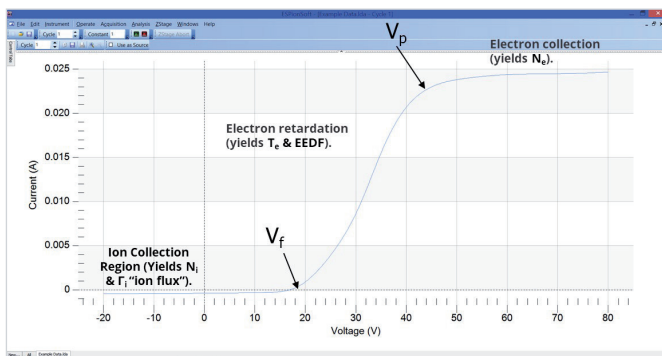

DATA SHOWING A TYPICAL I-V CURVE FROM AN RF PLASMA

Electron Energy Distribution Function, EEDF

EEDF is determined by the Druyvestyn method, using the second derivative of electron current with respect to voltage from the IV curve attained, the ESPionSoft software also provides additional measurements for T_e , N_e and EE.

$$f_E(V) = \frac{-4}{A_p e^2} \left(\frac{m_e (V_p - V)}{2e} \right)^{1/2} \frac{d^2 I_e(V)}{dV^2}$$

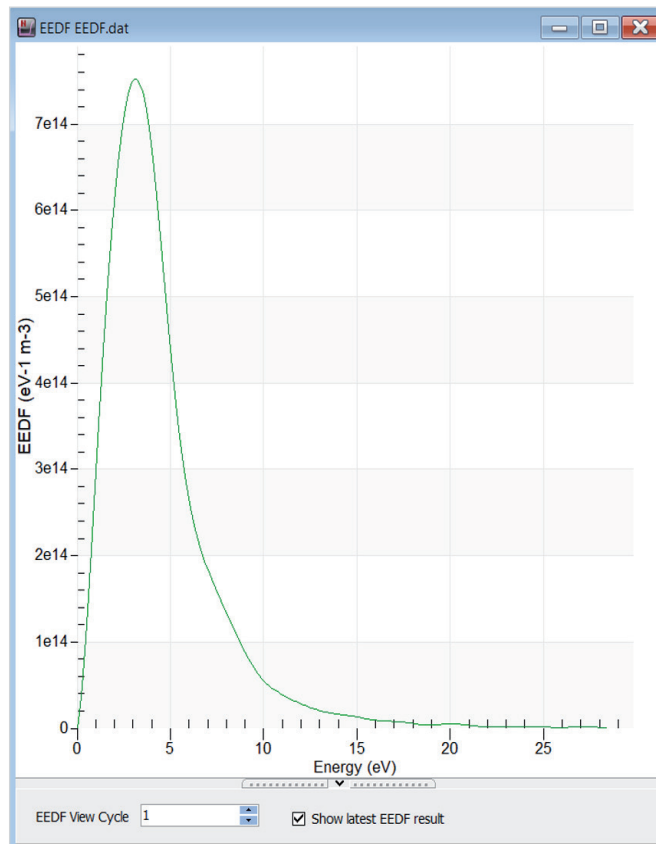

DATA SHOWING A TYPICAL EEDF CURVE FROM AN RF PLASMA

Example Data

System Configuration & Options

Data Filtering and Smoothing

The ESPionSoft software package is equipped with a Savitzky-Golay filter which allows the data to be digitally smoothed, improving the signal to noise ratio with minimal distortion.



TYPICAL DATA SHOWING A 5 POINT FILTER WIDTH

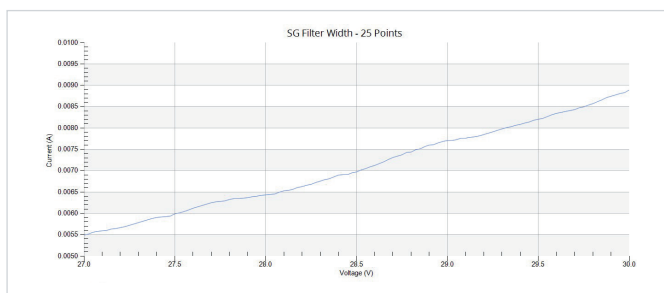

TYPICAL DATA SHOWING A 25 POINT FILTER WIDTH

The ESPion system can be configured with a wide range of customised options to suit many plasma conditions.

The end user can choose the system options to meet specific application requirements.

Option	Part No.
ESPion RF/DC complete static probe system 316.5 mm	950000
ESPion DC/HT complete static probe system 316.5 mm	950005
300 mm automatic bellows-sealed linear motion drive module	951000
600 mm automatic bellows-sealed linear motion drive module	956000
915 mm automatic bellows-sealed linear motion drive module	959150
200 mm manual movement bellow-sealed linear drive module	955200
300 mm manual movement bellow-sealed linear drive module	955201
Adjustable probe position module	955250
PC Computer with ESPionSoft Software Pre-Installed	800626
100 mm spacer nipple	952100
ESPion RF/DC probe, Insertion length 316.5 mm	952000
ESPion RF/DC probe, Insertion length 410 mm	952010
ESPion RF/DC probe, Insertion length 783 mm	952020
ESPion RF/DC probe, Insertion length 1164 mm	952030
ESPion DC/HT probe, Insertion length 316.5 mm	952005
ESPion DC/HT probe, Insertion length 410 mm	952015
ESPion DC/HT probe, Insertion length 783 mm	952025
ESPion DC/HT probe, Insertion length 1164 mm	952035
Pack of 5 cylindrical spare probe tips - Tungsten	950106
Pack of 5 cylindrical spare probe tips - Platinum	950110
Pack of 5 90 degree spare probe tips - Tungsten	950120
Pack of 5 90 degree spare probe tips - Platinum	950130
Pack of 5 planar spare probe tips	950140
ESPion RF/DC Spares Kit	950409
ESPion DC/HT Spares Kit	950415

Hidden **APPLICATIONS**

Hidden's quadrupole mass spectrometer systems address a broad application range in:

GAS ANALYSIS

- ▶ dynamic measurement of reaction gas streams
- ▶ catalysis and thermal analysis
- ▶ molecular beam studies
- ▶ dissolved species probes
- ▶ fermentation, environmental and ecological studies



SURFACE ANALYSIS

- ▶ UHV TPD
- ▶ ToF qSIMS and SIMS analysers
- ▶ end point detection in ion beam etch
- ▶ elemental imaging – 3D mapping

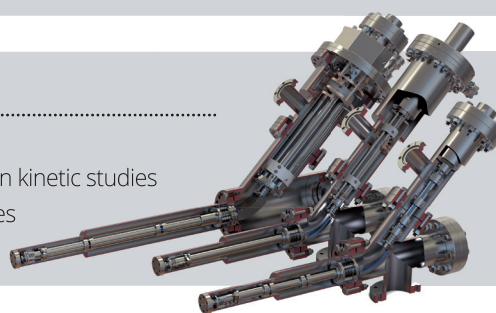

PLASMA DIAGNOSTICS

- ▶ plasma source characterisation
- ▶ etch and deposition process reaction kinetic studies
- ▶ analysis of neutral and radical species



VACUUM ANALYSIS

- ▶ partial pressure measurement and control of process gases
- ▶ reactive sputter process control
- ▶ vacuum diagnostics
- ▶ vacuum coating process monitoring

HIDEN

ANALYTICAL

Hidden Analytical Ltd.
420 Europa Boulevard
Warrington WA5 7UN England

T +44 [0] 1925 445 225
F +44 [0] 1925 416 518
E info@hidden.co.uk
W www.HiddenAnalytical.com



Sales Offices:

We have sales offices situated around the globe. **Visit our website for further information.**