

## Reliable Connections

Riveting | Joining | Roller Forming



# Then & Today

## Our history

- 1835:** M. Bräcker starts family business (textile components)
- 1968:** Bräcker launches radial riveting machine
- 1979:** Incorporation of Bräcker USA
- 1982:** Market introduction of PWS
- 1983:** Incorporation of BalTec Maschinenbau AG, MBO from Bräcker
- 1987:** Incorporation of BalTec UK
- 1990:** Takeover by Mr Fritz Bösch (from 1997 on part of Feintool)
- 1998:** Market introduction of first Process Controller
- 2000:** Discontinued production of PWS
- 2002:** Incorporation of BalTec France
- 2010:** Market introduction of HPP-25, 4<sup>th</sup> generation of Process Control
- 2011:** Spin-off from Feintool to Swiss investor group
- 2013:** Incorporation of BalTec do Brasil
- 2014:** Incorporation of BalTec Machinery (Shanghai) Ltd., P.R. China
- 2016:** 40'000 machines delivered since 1968
- 2017:** Introducing BalTec ELECTRIC
- 2018:** Incorporation of BalTec Mexico
- 2021:** Incorporation of BalTec Italy

1835

1968

1979

1982

1983

1987

1990



## We Are BalTec

### Our core competence

The core competence of the BalTec Group, headquartered in Pfäffikon, Switzerland, is in designing and manufacturing machines for radial riveting, orbital riveting, roller forming or for joining technologies.

Our products are used wherever high quality connections and joints are required in industries such as automotive, hardware industry, aerospace, and general industry. This also includes precision applications found in industries such as medical device, watch and specialty instruments.

We offer a wide range of solutions and develop processes for joining applications with demand for high quality, thanks to our extensive experience with a variety of joining technologies.

1998

2000

2002

2010

2011

2013

2014

2016

2017

2018

2021





# Worldwide Presence

## Direct operations & Many representatives

BalTec is represented worldwide with its own companies and plant locations – Switzerland, USA, Germany, France, United Kingdom, Brazil, China, Spain, Italy and Mexico – and 40 distribution partners. Due to our diversified sales & support network distributed throughout the world, we can offer professional service local to you.







## Our worldwide competence and technology centers

To find the perfect solution for your particular application, we conduct feasibility studies in regard to material, joining process, required force, forming tool design and much more.

Together with you, we develop the best process in regard to technical & economical requirements. Take advantage from this wealth of experience gathered by BalTec technicians and engineers over several decades!

- Switzerland
- Germany
- USA
- UK
- France
- Brazil
- China
- Netherlands
- Sweden
- Italy
- Czech Republic
- Poland
- Japan
- Thailand
- India
- S. Korea

# Application Examples

Automotive

Hardware industry

Electrical & Electronics

Fine mechanics & Watches

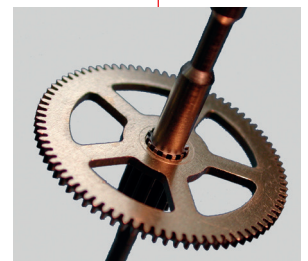
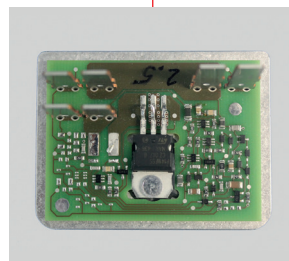
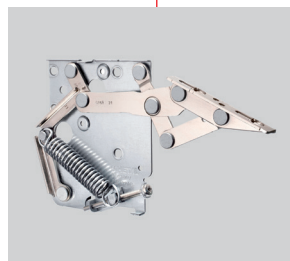
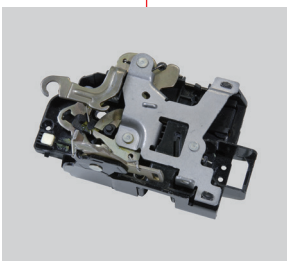
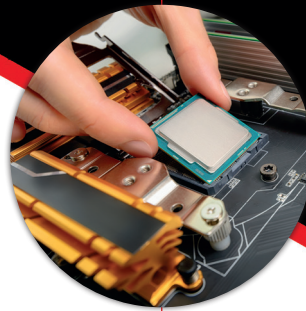



# Simply Perfectly Joined

Medical device industry

Consumable goods & Leisure

Home & Gardening

General industry

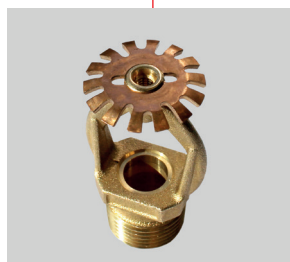
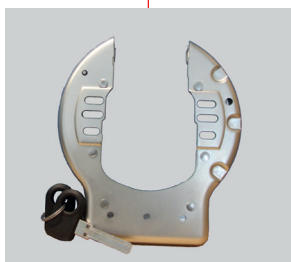
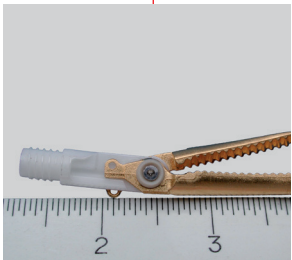
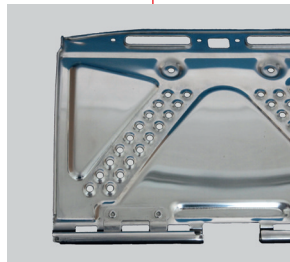
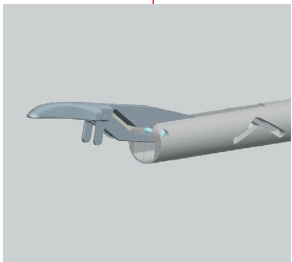



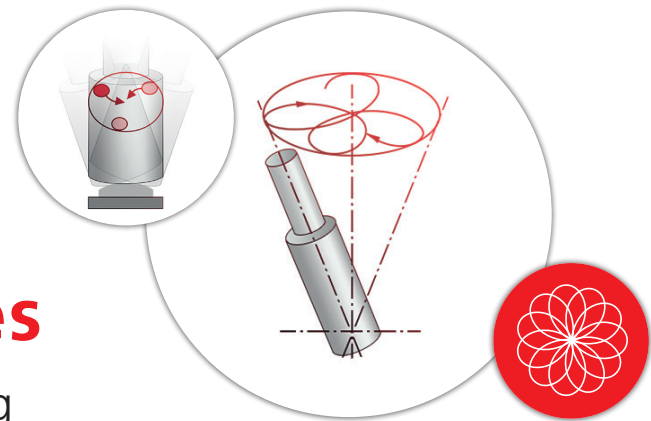

# Forming Processes

## Radial, Orbital, Roller forming

### Processes

The application determines the process. In most cases however, where high-quality joints are a requirement, the radial riveting technology is the appropriate procedure due to the low cycle time, the little force needed and the high quality results obtained.

Selection criteria are:

- Material (solid or tubular)
- Material form (round or unshapely)
- Cycle points per workpiece (one point or several points per workpiece)
- Diameter (for tubular material)
- Material hardness
- Wall thickness
- Desired result of deformation (pure forming or marking)
- Further criteria

### Radial

Process:

The forming tool describes a rose petal path which results in a flowing and gentle deformation of material with the least possible force applied to the work piece. The rivet gets deformed in three directions.

Radially outwards, radially inwards and overlapping also tangential.

- Excellent surface structure of the closing heads
- Forming tool does not rotate – minimal friction between tool and workpiece
- Low stress on the components. Allows the processing of products which contain e.g. bakelite, ceramic or other brittle materials
- Simple workpiece holding thanks to minimal lateral forces. Clamping of the workpiece not usually required
- Long lifetime of machines and tools
- Optimal cost-effectiveness over the entire lifetime (TCO)

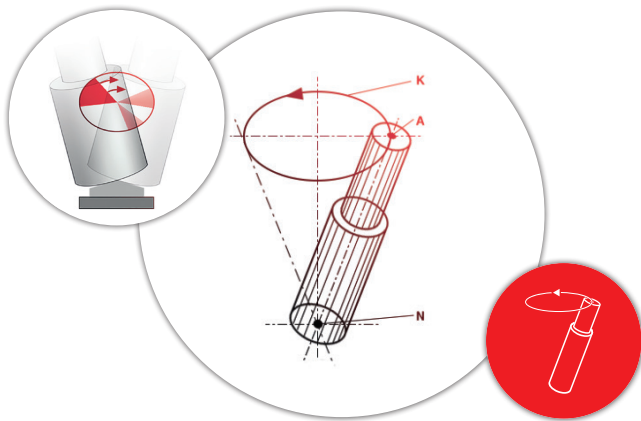

## Orbital

Process:

The center axis of the riveting peen operates in rotating path. The peen tip which contacts the rivet, signifies the pivot point, whereby the peen follows a circular motion. This motion creates a pie-like contact area on the rivet. The deformation flows around the rivet head.

- Less gentle than radial forming
- Hardening on the formed workpiece is clearly visible
- Suitable for forming pieces with larger diameters and annular forms
- Requires good workpiece holding, which absorbs lateral forces

### Tangential

Process: Tangential riveting is a form of radial riveting, except that the rivet temple path does not cross the middle. This riveting process is used in special cases. The forming tool does not rotate and there is only minimal friction between tool and workpiece.

The lifespan of machines and tools is long and total lifetime cost-effectiveness (TCO) is optimal.

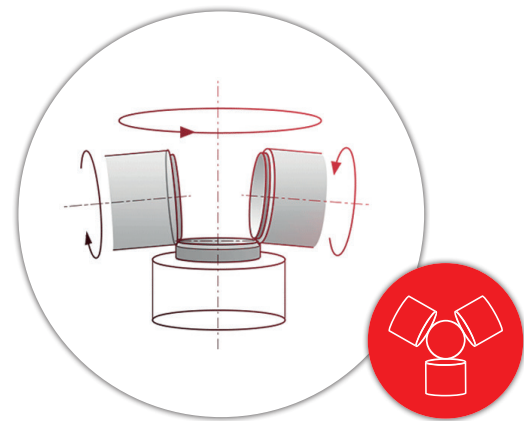

## Roller forming

Process:

The forming is achieved by profile rollers, which are mounted on a rotating spindle and roll on the formable part.

- Allows forming of tight angles
- Good sealing properties of the formed workpiece
- Minimal axial force – minimal compression of the workpiece
- Specially suitable for large diameters or thin wall applications
- Initial costs for forming workpiece are high compared with radial or orbital
- Roller forming head is manufactured specific to the application
- Design, number of rolls and rotational speed per the application
- Axial or radial forming direction possible

# Product Families

ELECTRIC, CLASSIC-HPP, CLASSIC



**ELECTRIC**



**CLASSIC-HPP**



**CLASSIC**

<b>Process</b>	Radial Orbital Roller forming	Radial Orbital Roller forming	Radial Orbital
<b>Process monitoring</b>	YES	YES	NO
<b>Rivet-/form-starting detection</b>	Integrated in the stroke movement, flexible and dynamically definable	Integrated in the stroke movement, dynamic	NO
<b>Process control</b>	Motion profiles can be totally customized. One process cycle can consist of an unlimited number of profile segments	6 control parameters 40 pre-installed programs	Time controlled
<b>Control parameter</b>	S = Stroke F = Force T = Time E = Position of spindle / stroke vl = Feed rate vr = Rotation speed B = Basic reference (with NHE) H = Rivet height (with NHE) Z = Stroke pre position	S = Stroke F = Force T = Time E = Position of spindle (stroke) B = Basic reference (with NHE-U) H = Rivet height (with NHE-H)	T = Time
<b>Minimal content of delivery</b>	Unit with control box and Software (Windows 10)	Unit with control box and integrated touch screen (HMI)	
<b>CE conformity</b>	Yes, as working station with light barrier or stroke door	Yes, as bench top working station with two-hand control	
<b>Communication protocols</b>	IP/Ethernet & UDP protocol OPC UA on request	IP/Ethernet & UDP protocol	NO



# For Every Application The Perfect Machine

thanks to flexible and modular configurations

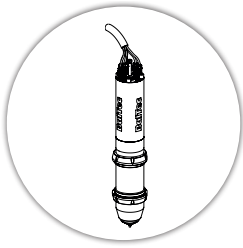

**Ex U**  
ELECTRIC unit:  
Power module inclusive  
cables and threaded rings  
for installation

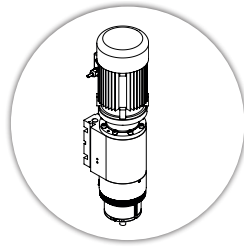

**RNE**  
Radial riveting unit: ideal for  
integration – in any desired  
position – or as combination  
with various machines

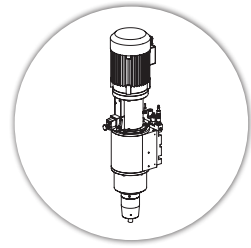

**ENE**  
Orbital riveting unit: ideal for  
integration – in any desired  
position – or as combination  
with various machines

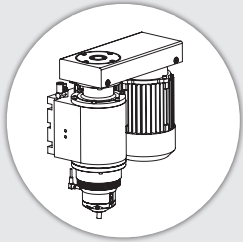

**RNE lateral**  
Unit with lateral  
mounted motor  
to reduce height  
of construction

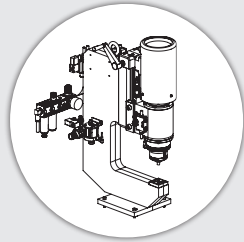

**RNE M1**  
Unit with C frame and  
height adjustment with  
crank mechanism; ideal  
for integration into  
plants

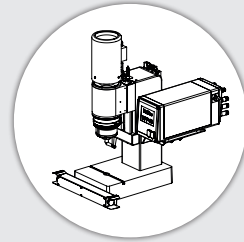

**RN**  
Bench top riveting  
machine: Unit with  
column incl. crank  
mechanism and  
table

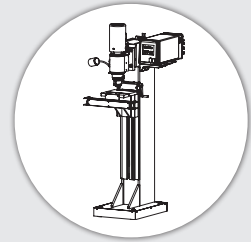

**RNS**  
Pedestal riveting  
machine: Riveting  
machine with  
adjustable working  
table. Available with  
safety enclosure

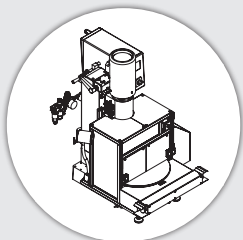

**RNR**  
Working station:  
Column and riser  
plate, electrical rotary  
indexing table with  
6 or 4 stations,  
safety enclosure

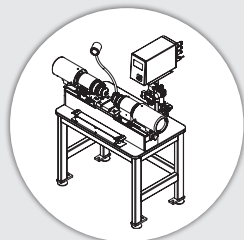

**RND**  
Bench top model /  
working station:  
Two units assembled  
on supporting table

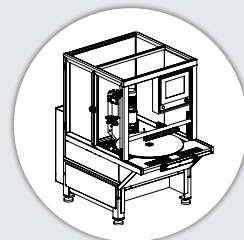

**RNC RT & TR**  
Work cells:  
Coordinate riveting  
machine with rotary  
indexing table or for  
belt transfer system

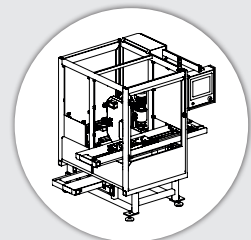

**Custom specific  
work cells**  
Complete systems  
with workpiece  
holders and control

# Process Monitoring

## Precision & Reliability

Whether in the automotive or electronics industry, the consumer goods industry, the hardware industry or medical technology – the control and monitoring of forming processes is the basis of every successful industrial production.

For over 20 years BalTec has been offering the patented process control which was especially developed for radial riveting and is now used in all joining processes of BalTec.

The basis of the process control is the monitoring of the force-stroke curves over the time track using state-of-the-art sensor technology.

Your benefit – the competitive advantage:

- Compliance and verification of predefined quality characteristics
- Proof of quality through complete documentation of the process
- Reduction of rejects and rework costs
- Reduced process times thanks to dynamic workpiece recognition (NA)
- Important for proof of process capability and productliability

### Process diagram (STF = Stroke | Time | Force)

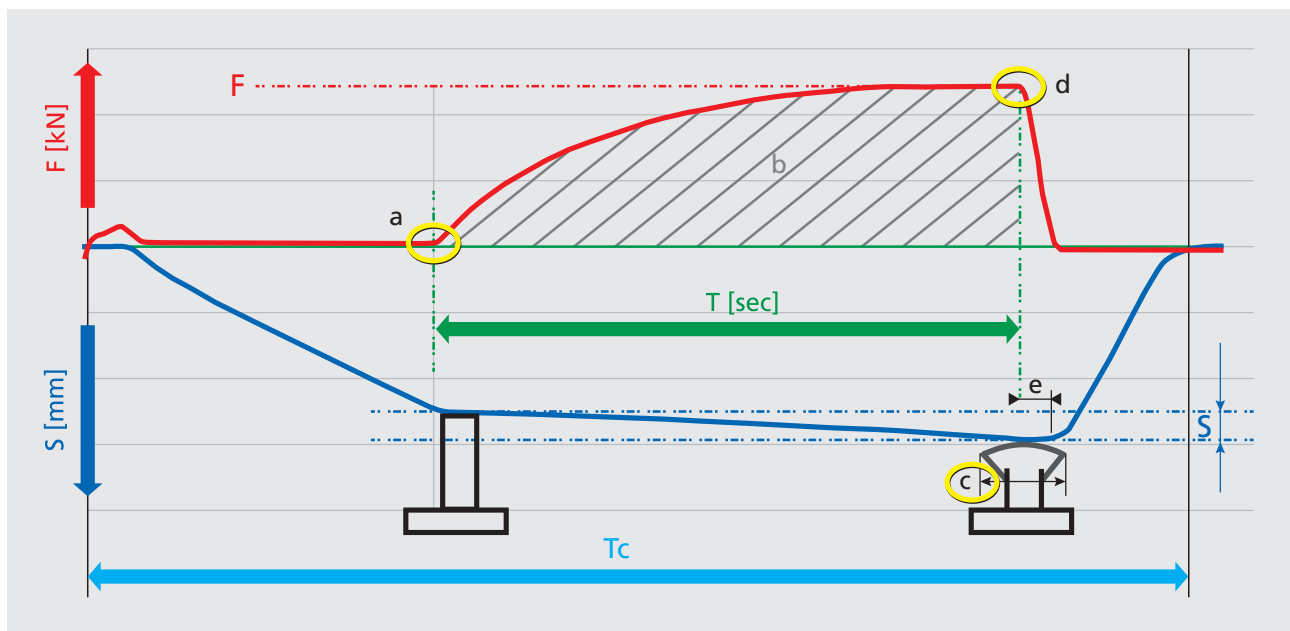

#### Legend

- |                 |  |                           |
|-----------------|--|---------------------------|
| T: Forming time | a: Rivet contact point (NA)                  | d: End of forming process |
| Tc: Total cycle | b: Forming of workpiece                      | e: Response time lag      |
| S: Stroke       | c: Achieved dimensions within specifications |                           |
| F: Force        |  |                           |

## Process Control HPPi (ELECTRIC)

The HPPi software was developed specifically for the ELECTRIC product line. This software is Windows 10 compliant and serves as an HMI (Human Machine Interface) portal for the safe, efficient and productive use of the ELECTRIC machine. The package is EMC-secured and meets the highest safety standards in mechanical engineering. Predefined motion profiles allow flexible programming and parameterization of application-specific profiles for forming and riveting processes to achieve high machine capabilities (CpM) with the world's most unique rivet start detection. The visualization and graphical presentation convince with a clear and organized structure and support process data management. With open communication channels to and from a higher-level control system, it meets the latest standards in the context of Industry 4.0.

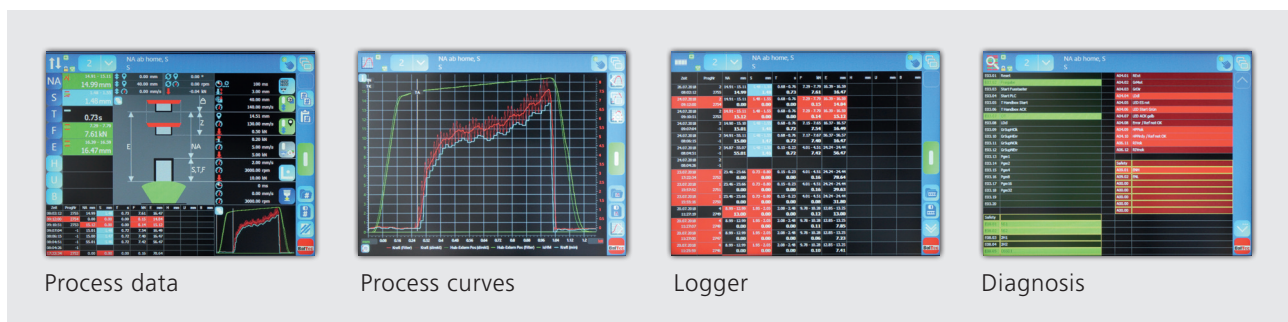

## Process Control HPP-25 (CLASSIC-HPP)

Central and unique function of the Process Control HPP-25 is the patented and fastest detection of the workpiece. The beginning of the forming process is registered without loss of speed and without previous scanning. The HPP-25 can be used for all pneumatic and hydraulic machines equipped with position and force sensors. The simple operation with 6 different control sizes and more than 40 predefined modes allows a direct, fast and flexible adaptation to new production needs. Visualization of process data and force / stroke process curves are included in the standard scope of delivery. Optionally, a PC tool (Windows 10) is available. Communication to and from a higher-level control system takes place via predefined digital I/O. For the transmission of process data via UDP, an IP/Ethernet interface is available as standard. As an alternative to the UDP protocol, an interface to Siemens PLC (S7-300 | S7-400 | S7-1200 | S7-1500) is optionally available.

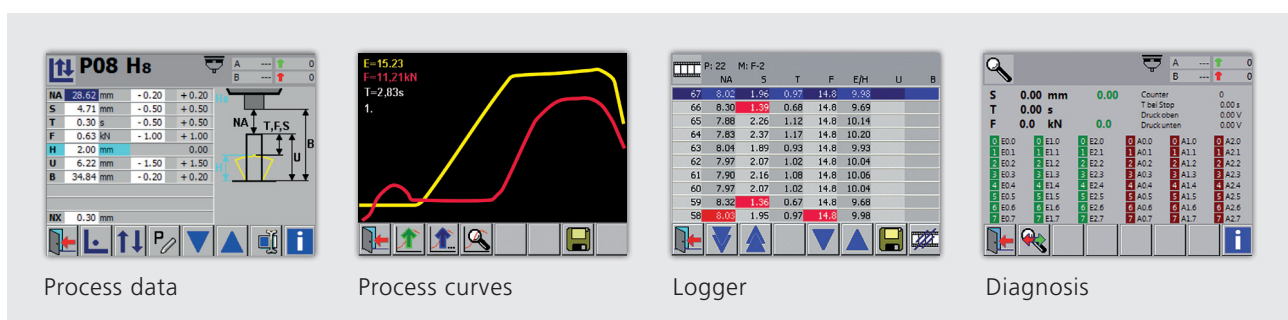



# Control & Accessories

## Time Based Control RC-30 (CLASSIC)

The forming process is controlled by time setting. The control is modular and can be used with pneumatic and hydraulic riveting machines, rivet base detection devices, rotary indexing table riveting machine and sliding tables.

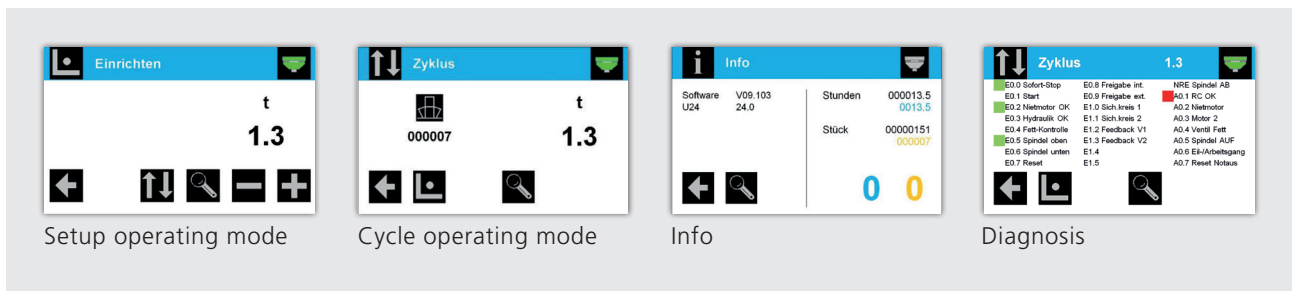

## Rivet base detection device NHE

Depending on the equipment, the NHE checks before riveting the presence of the components, the position and the rivet protrusion. Processing components out of tolerance or missing components shall be prevented.

As a result, cost for most pre- or post-inspection stations of parts can be eliminated and saved, since the HPP-25 handles quality monitoring.

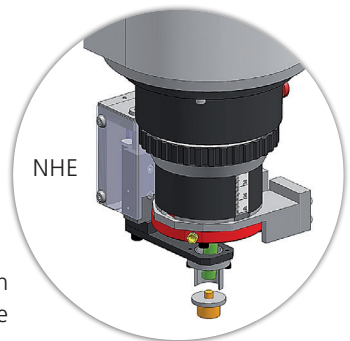

Touch probe

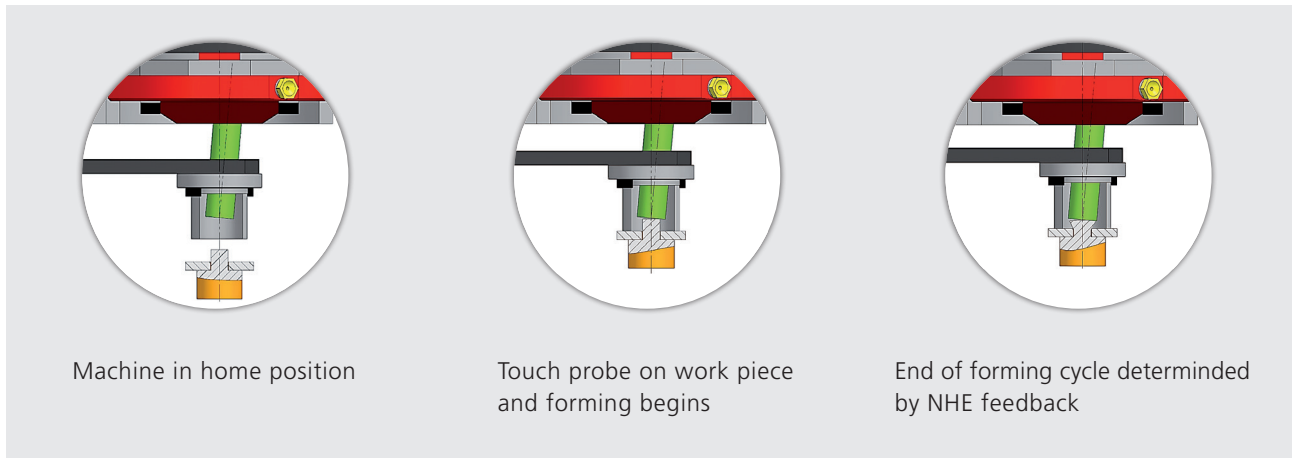

## Multiple riveting head

With the MRX multi-head riveting option, multiple rivet points can be formed within a specific center-to-center dimensional range. The generated force by the machine is distributed proportionally between all riveting tools. Riveting at varying height is possible based on specific application. The lateral movement of the riveting tool is equal to the well known Rosette pattern of the BalTec radial riveting machines.

MRX: Minimum and maximum distances between rivet positions:

Type	min.	max. standard	max. special	Force/Pos.
1	8.0 mm	60 mm	70 mm	6.0 kN
2	15.5 mm	72 mm	85 mm	8.5 kN
3	15.5 mm	106 mm	120 mm	8.5 kN

Further details see technical data sheet.

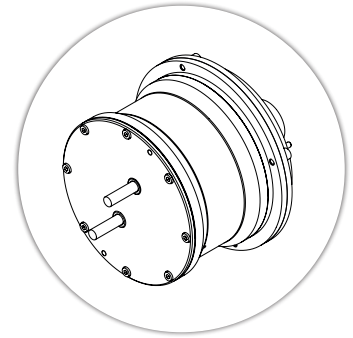

## Roller forming head

The forming is achieved via profile rollers, attached to a roller head, driven by a riveting machine. This process allows forming of diameters far larger than possible with radial or orbital process, at a much lower force. Since the profile rollers roll over the feature of the work piece, friction is at an absolute minimum, which results in greatly reduced wear & tear and typically long roller life. Normally, a roller forming head is customized in regard to design, size and concept based on the application. Additionally the number of rollers, head rotational speed and also the required force are all variables to be considered.

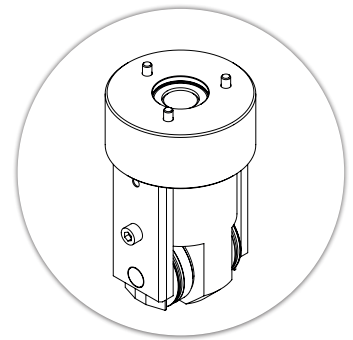

## Sliding table

Thanks to a manual or pneumatic sliding table, workpieces can be placed outside of the riveting station, making work easier. As an option, both versions (manual and pneumatic) are also available with an initiator for monitoring the sliding table in the riveting position. An additional safety enclosure also allows automatic operation without two-hand operation.

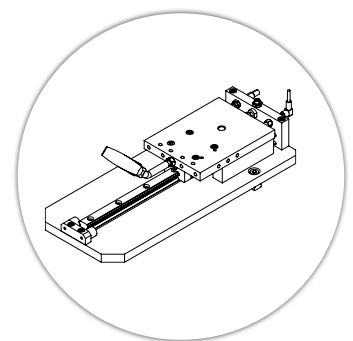

## Downholder

Used to seat, compress or insert workpieces before riveting or forming. Available for every machine model. A large force range is possible, depending on the chosen spring pack. With spiral springs, a very compact but open design is possible. Disk springs offer very high forces, within a closed housing.

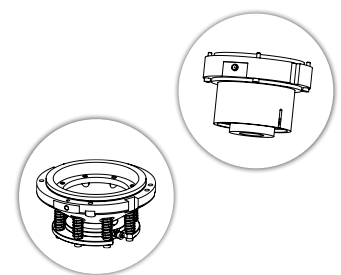



# Our Services

## Forming tools & Repair parts

- All BalTec forming tools and spare parts (pressure cup, form tool holder) are manufactured at the head office or in the BalTec USA branch to the same high standard
- Common parts such as bearing and seal kits, pneumatic control components, electric motors and critical spindle components are available from stock
- BalTec forming tools are known for their long service lives
- Depending on the application, we also offer special tool coatings for longer service life or lower friction. Take advantage of our many years of experience



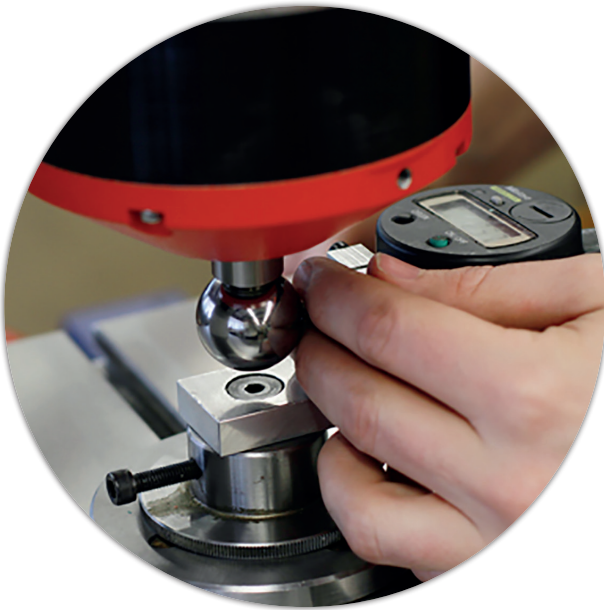

## Repair / Service

- Repair of your machine in a BalTec technology center
- Repair of your machine in your production facility with minimal loss of production
- After repairing a machine in a technology center, the machine undergoes the same performance test as a new delivery
- After evaluation / before executing the repair, a binding offer will be issued
- Telesupport or support via TeamViewer possible; depending on product
- Certificate of ability available on request

## Training

- Individual training at your location or with us in one of our technology centers:
  - Basic knowledge of operation, setup, programming, definition of quality parameters
  - Recessed operation; NHE, Smooth Finish, auto compensation
  - Evaluation & interpretation of process data, process optimization
  - Setting up for new applications
  - Preventive maintenance and repair techniques and measures
- BalTec develops application-specific tool geometries inclusive marking tool

Contact us or your local contact person also for:

- Framework agreements
- Scheduled delivery dates
- Volume discounts
- Custom offers and programs



# Models

## ELECTRIC, CLASSIC-HPP, CLASSIC

Model	Process	Shank <sup>1</sup> diameter mm	VS <sup>9</sup> mm/Sec.	VR <sup>9</sup> min <sup>-1</sup>	F <sup>9</sup> kN	S mm	G Unit <sup>2</sup> kg
ER 03 / ET <sup>0</sup> 03	Radial	2.0	0.05-140	0-3000	3.0	0-100	28.0
ER 15 / ET <sup>0</sup> 15	Radial	10.0	0.05-140	0-3000	15.0	0-100	28.0
ER 30 / ET <sup>0</sup> 30	Radial	15.0	0.05-180	0-2000	30.0	0-200	120.0
ER 50 / ET <sup>0</sup> 50	Radial	20.0	0.05-120	0-2000	50.0	0-200	120.0
EO 03	Orbital	2.0	0.05-140	0-3000	3.0	0-100	28.0
EO 15	Orbital	10.0	0.05-140	0-3000	15.0	0-100	28.0
EO 30	Orbital	15.0	0.05-180	0-2000	30.0	0-200	120.0
EB 03	Roller forming	–	0.05-140	0-1000	3.0	0-100	28.0
EB 15	Roller forming	–	0.05-140	0-1000	15.0	0-100	28.0
EB 30	Roller forming	–	0.05-180	0-800	30.0	0-200	120.0

Model	Process	Shank <sup>1</sup> diameter mm	HPP-25	RC-30	F kN	S mm	G Unit kg	G Machine <sup>3</sup> kg
RNE   RN 081	Radial <sup>0/5</sup>	4.0	–	X	2.4	2-25	20.0	41.0
RNE   RN 151	Radial <sup>0/5</sup>	2.0	X	X	1.5	5-30	30.0	80.0
RNE   RN 181	Radial <sup>0/5</sup>	6.0	X	X	6.6	5-30	30.0	80.0
RNE   RN 181R	Radial <sup>0/5</sup>	4.0	X	X	3.6	5-30	30.0	80.0
RNE   RN 231	Radial <sup>0/5</sup>	8.5	X	X	12.0	5-40 <sup>8</sup>	35.0	85.0
RNE   RN 231R	Radial <sup>0/5</sup>	6.0	X	X	6.2	5-40	35.0	85.0
RNE   RN 281	Radial <sup>0/5</sup>	12.0	X	X	17.0	5-40 <sup>8</sup>	60.0	155.0
RNE   RN 281R	Radial <sup>0/5</sup>	7.5	X	X	9.5	5-40	60.0	155.0
RNE   RN 331	Radial <sup>0/5</sup>	16.0	X	X	33.0	5-50 <sup>8</sup>	110.0	240.0
RNE   RN 381	Radial <sup>0/6</sup>	20.0	X	X	40.0	5-50 <sup>8</sup>	80.0	200.0
RNE 431	Radial <sup>0/6</sup>	24.0	X	X	60.0	5-50	80.0	–
RNE 481   RNS 481 <sup>7</sup>	Radial <sup>0/6</sup>	30.0	X	X	100.0	5-90	180.0	1030.0
ENE   EN 20	Orbital <sup>5</sup>	13.0	X	X	20.0	5-40	110.0	220.0
ENE   EN 20R	Orbital <sup>5</sup>	7.5	X	X	9.5	5-40	110.0	220.0
ENE   EN 35	Orbital <sup>5</sup>	18.0	X	X	35.0	5-50	120.0	270.0
RLE   RL 01 <sup>4</sup>	Roller forming <sup>5</sup>	–	X	–	1.5	5-30	30.0	–
RLE   RL 06 <sup>4</sup>	Roller forming <sup>5</sup>	–	X	–	6.0	5-30	30.0	–
RLE   RL 12 <sup>4</sup>	Roller forming <sup>5</sup>	–	X	–	12.0	5-40	35.0	–
RLE   RL 20 <sup>4</sup>	Roller forming <sup>5</sup>	–	X	–	20.0	5-40	110.0	–
RLE   RL 35 <sup>4</sup>	Roller forming <sup>5</sup>	–	X	–	35.0	5-50	120.0	–
RLE   RL 40 <sup>4</sup>	Roller forming <sup>6</sup>	–	X	–	40.0	5-50	80.0	–

S = Stroke

F = Max. forming force

VR = Rotational speed

VS = Linear speed

G = Weight without forming tool

<sup>0</sup> Tangential

<sup>1</sup> Steel 370 N/mm<sup>2</sup>

<sup>2</sup> Weight without adapter

<sup>3</sup> Weight without control

<sup>4</sup> Weight without roller forming head

<sup>5</sup> Pneumatic

<sup>6</sup> Hydraulic

<sup>7</sup> Only available as RNS

<sup>8</sup> Longstroke available on request

<sup>9</sup> Restrictions reserved

Machine sizes determined by specific application | Further versions (see page 11) on request  
Subject to technical changes

# Forming Tools

High quality spare parts and forming tools are made in-house – standard and customer specific applications

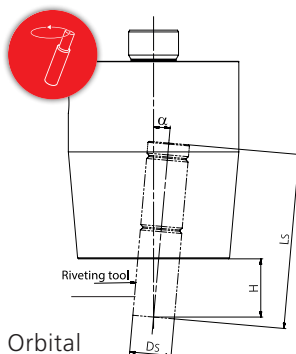
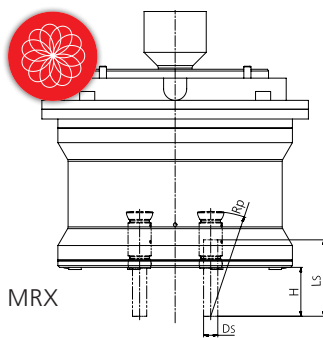
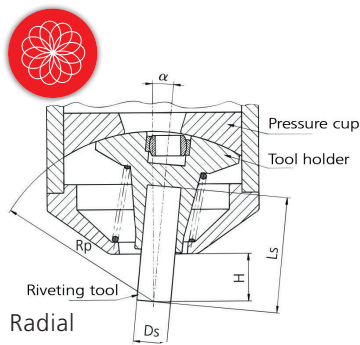

Model	Process	Radius mm Rp	Tool length mm Ls	Free height mm H	Shank diameter mm Ds	Angle of inclination α		
<b>RN/RNE</b> 081, 151, 181/R, 231/R	Radial	65	39	18.0	10	6° 02'		
		80	54	33.0	10	4° 47'		
		100	74	53.0	10	3° 44'		
		120	94	73.0	10	3° 04'		
<b>ER/ET</b> 03,15	Radial	132	106	85.0	10	2° 46'		
		100	68	28.0	20	5° 37'		
<b>RN/RNE</b> 281/R, 331, 381, 431	Radial	116	84	44.0	20	4° 47'		
		132	100	60.0	20	4° 10'		
		148	116	76.0	20	3° 41'		
		170	138	98.0	20	3° 10'		
		191	159	119.0	20	2° 49'		
<b>ER/ET</b> 30, 50	Radial	240	208	168.0	20	2° 13'		
		148	100	45.0	30	6° 15'		
		196	148	93.0	30	4° 38'		
		240	192	137.0	30	3° 45'		
<b>RN/RNE</b> 481	Radial	290	242	187.0	30	3° 04'		
		40	40	18.0	5	4° 17'		
		<b>MRX 1</b>	Radial	59	43	27.0	8	5° 23'
				78	62	36.5	8	4° 11'
88	72			41.5	8	3° 65'		
106	76			50.5	8	3° 03'		
<b>MRX</b> 2, 3	Radial	–	84	28.0	20	5°		
		–	116	60.0	20	3°		
<b>EN/ENE</b> 20/R, 35 <b>EO 30</b>	Orbital	–	54	28.0	10	5°		
		–	54	28.0	10	3°		
<b>EO</b> 03, 15	Orbital	–	54	28.0	10	5°		
		–	54	28.0	10	3°		

For further forming tool lengths (Ls) / angle (α) please contact us | The tool length (Ls) and the radius of the holder (Rp) result from your desired free height (H) | Roller forming tools are produced customer specific | Subject to technical changes

## 10 typical tool profiles

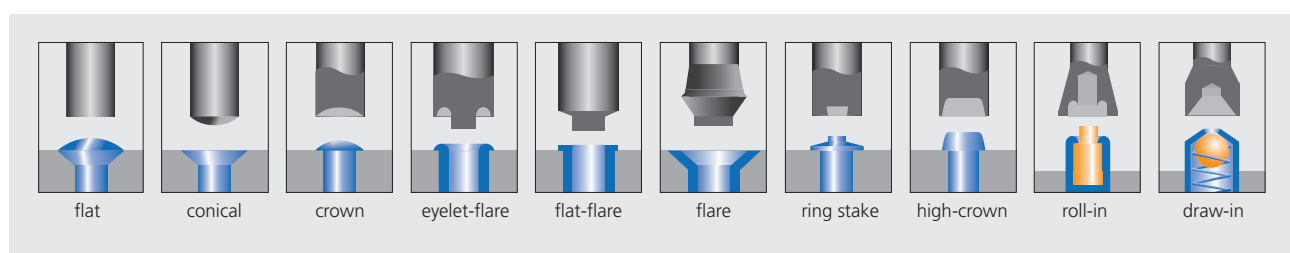

**Who we are**

With its headquarter in Pfäffikon (Zurich), Switzerland, the core competence of BalTec group is in the manufacturing of machinery for joining technology, with a focus on radial riveting process, but also orbital riveting, roller forming and joining. As early as 1968, BalTec (then still known as Bräcker) had already produced radial riveting technology, a process well known in a variety of industries. Today we are the global leader in riveting and cold forming technology. BalTec has direct operations in 7 countries with approximately 60 direct employees and is represented through over 40 sales partners around the globe.

**What we offer**

We firmly believe that the high-level of quality and customer satisfaction provided by BalTec can only be achieved by a strong local presence. Our technology and service center provide world wide support to machine builders as well as process development and testing for end users while defining the most suitable process. This competent and personal support is provided by BalTec employees or our trained representatives, close to your location.

**Where we aim to go**

Our position as a technology leader defines our focus for the future. We continuously thrive to improve this position and our offerings, in order to provide optimal and sustainable solutions to our customer in conjunction with joining technologies. With the patented HPP, a process data management system with integrated and intuitive machine control, we have created a new benchmark in process monitoring. A capability that allows the customer to achieve a clear cost advantage.

**We are BalTec**

Our strongest asset? Beyond any doubt, it is our committed and motivated employees, many of whom have gained a wealth of experience over many years. Together, we pursue a single goal with absolute dedication: customer satisfaction. Please arrange an appointment and take advantage of our experience.



SWISS MADE

**Headquarters:**

BalTec AG  
8330 Pfäffikon (ZH), Switzerland  
Tel. +41 44 953 13 33  
baltec@baltec.com  
www.baltec.com

**The BalTec group:****Switzerland / Germany**

BalTec AG

**United Kingdom**

BalTec (UK) Ltd.  
Reading, Berkshire, England

**France**

BalTec France  
Rambouillet, France

**USA / Canada / Mexico**

BalTec Corporation  
Canonsburg, PA, USA

**Brazil**

BalTec do Brasil  
Jundiaí, Brazil

**China**

BalTec Machinery (Shanghai) Ltd.  
Shanghai, P.R. China

**Italy**

BalTec Italia S.r.l.  
Schio (VI), Italy

Joining is our business – worldwide

**BalTec**