

ELECTRIC



Efficient & compact

Riveting | Cold forming | Roller forming
Servo technology

BalTec

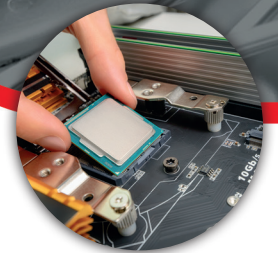

Speed, precision, flexibility

- Compact, slim design. Ideal for integration in cases of limited space.
- 100% electrically powered forming energy. No emission of oil vapor.
- Low noise emission.
- Exceptional energy efficiency, greatly reduced operating cost.
- Reduced process time yields increased output.
- Industry 4.0 ready. Process data collection, remote access to data, parameters and programs.
- 100% Real time process control AND monitoring. Linear force, speed and position are monitored at any point in the cycle.
- The power module was developed for different forming technologies – radial, orbital, and roller forming. The process head is interchangeable.
- Motion profiles can be totally customized. One process cycle can consist of an unlimited number of profile segments.
- Highest power to space ratio in regard to form factor.
- Inline force measurement.



Added value

As compared to conventional joining technologies



Increased productivity & reduced maintenance costs.



More compact design allows tighter positioning in assembly lines.



Greatly reduced operational costs compared to conventional systems.



Protected investment, as this machine is easily adaptable to new products and can meet a greater range of production requirements.



Immediate product fault and error detection by means of integrated 100% quality monitoring and traceability.



Optimal Productivity

due to innovative technology

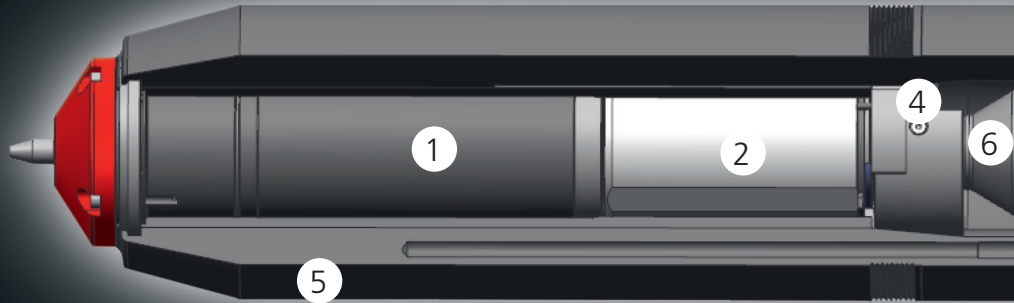

1 Process head

- Radial*
- Tangential
- Orbital
- Roller forming



* (mechanically identical to classical RN-line)

2 Rotational drive

- Variable RPM
- Electrical overload protection
- Temperature sensor

3 Linear drive

- Motion profiles totally customized
- Mechanical overload protection
- Temperature sensor

4 Motor control

- Rotary encoder
- RPM sensor

5 Linear measurement

- Direct measurement of process head
- Programmable stroke increment: 0.01 mm
- System resolution, stroke: 0.0005 mm

6 Force measurement

- Direct
- Inline

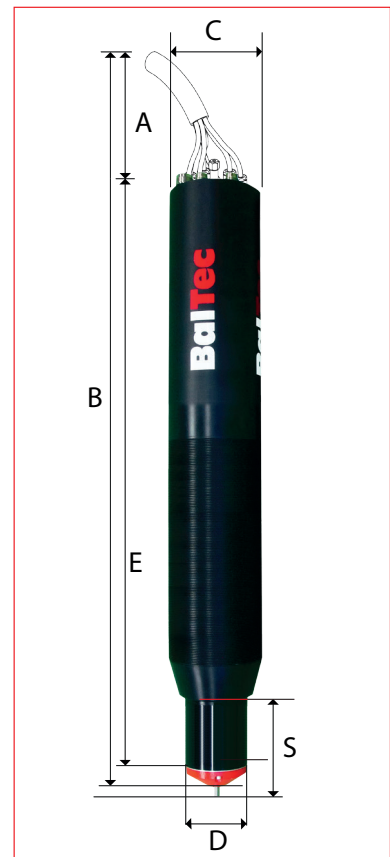



Patented

Measurements in mm

	E 03	E 15	E 30	E 50
A	min. 200	min. 200	min. 218	min. 218
B	min. 874	min. 874	min. 1283	min. 1283
C	120	120	180	180
D	80	80	140	140
E	674	674	1022	1022
S	0-100	0-100	0-200	0-200

ELECTRIC

Model	Process	Rivet ¹ max. Ø	vs ⁹ mm/Sec.	vr ⁹ min ⁻¹	F ⁹ kN	S mm	G kg
ER 03 / ET 03	Radial/Tangential	2.0	0.05-140	0-3000	3.0	0-100	28.0
ER 15 / ET 15	Radial/Tangential	10.0	0.05-140	0-3000	15.0	0-100	28.0
ER 30 / ET 30	Radial/Tangential	15.0	0.05-180	0-2000	30.0	0-200	120.0
ER 50 / ET 50	Radial/Tangential	20.0	0.05-120	0-2000	50.0	0-200	120.0
EO 03	Orbital	2.0	0.05-140	0-3000	3.0	0-100	28.0
EO 15	Orbital	10.0	0.05-140	0-3000	15.0	0-100	28.0
EO 30	Orbital	15.0	0.05-180	0-2000	30.0	0-200	120.0
EB 03	Roller forming	–	0.05-140	0-1000	3.0	0-100	28.0
EB 15	Roller forming	–	0.05-140	0-1000	15.0	0-100	28.0
EB 30	Roller forming	–	0.05-180	0-800	30.0	0-200	120.0

vs = Linear speed
vr = Rotational speed

F = Max. forming force
S = Stroke
G = Weight of unit

¹ Steel 370 N/mm²
⁹ Subject to restrictions

Machine sizes determined by specific application | Subject to technical changes

Plug & Run

in one package



Power Module

- Including cables and threaded rings for installation



Control

- Logic module
- Safety module
- Power supply & distribution
- Motor drives
- Ethernet/IP & USB
- Remote access



Radial

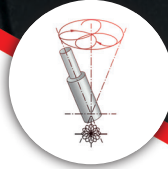

Orbital

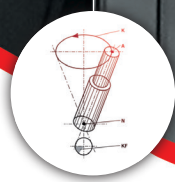

Roller forming

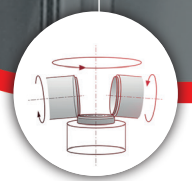

Joining Process

HPPi Software

- Runs on Windows 10
- Pre-defined, adjustable motion profiles
- Flexible programming & parameter definition of custom profiles
- Visualization / graphical display
- Customizable process data acquisition



Simple integration

for flexible operation

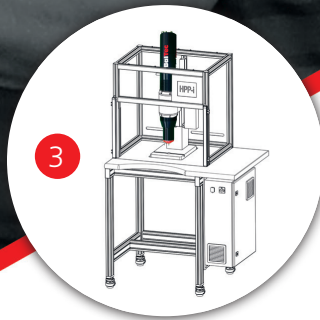
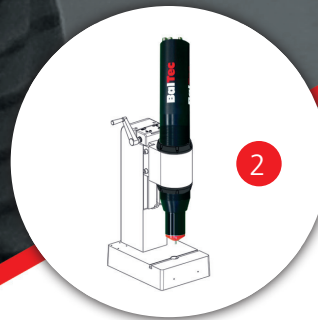

Installation Options

- Flange or side mount possible
- Retrofit in existing production lines

Configurations

- Suitable for a variety of configurations including our existing models

Complete workstation

- CE compliant or as alternative UL compliant

Downholder / Pressure pad

- With base detection

User interface

- 10.4" touch panel, pre-configured PC with HPPi
- 4" terminal for visualization
- Integrated OPC-UA license (Industry 4.0 ready)

Who we are

With its headquarter in Pfäffikon (Zurich), Switzerland, the core competence of BalTec group is in the manufacturing of machinery for joining technology, with a focus on radial riveting process, on orbital and tangential riveting or roller forming. As early as 1968, BalTec (then still known as Bräcker) had already produced radial riveting technology, a process well known in a variety of industries. Today we are the global leader in riveting and cold forming technology. BalTec has direct operations in 7 countries with approximately 60 direct employees and is represented through over 40 sales partners around the globe.

What we offer

We firmly believe that the high-level of quality and customer satisfaction provided by BalTec can only be achieved by a strong local presence. Our technology and service center provide world wide support to machine builders as well as process development and testing for end users while defining the most suitable process. This competent and personal support is provided by BalTec employees or our trained representatives, close to your location.

Where we aim to go

Our position as a technology leader defines our focus for the future. We continuously thrive to improve this position and our offerings, in order to provide optimal and sustainable solutions to our customer in conjunction with joining technologies. With the patented HPP, a process data management system with integrated and intuitive machine control, we have created a new benchmark in process monitoring. A capability that allows the customer to achieve a clear cost advantage.

We are BalTec

Our strongest asset? Beyond any doubt, it is our committed and motivated employees, many of whom have gained a wealth of experience over many years. Together, we pursue a single goal with absolute dedication: customer satisfaction. Please arrange an appointment and take advantage of our experience.

Headquarters:

BalTec AG
8330 Pfäffikon (ZH), Switzerland
Tel. +41 44 953 13 33
baltec@baltec.com
www.baltec.com

The BalTec group:**Switzerland / Germany**

BalTec AG

United Kingdom

BalTec (UK) Ltd.
Reading, Berkshire, England

France

BalTec France
Rambouillet, France

USA / Canada / Mexico

BalTec Corporation
Canonsburg, PA, USA

Brazil

BalTec do Brasil
Jundiaí, Brazil

China

BalTec Machinery (Shanghai) Ltd.
Shanghai, P.R. China

Italy

BalTec Italia S.r.l.
Schio (VI), Italy



SWISS MADE

Joining is our business – worldwide

BalTec