



Powder/ Liquid Mixers



The Silverson Principle

For over 75 years Silverson has specialised in the manufacture of quality high shear mixers for processing and manufacturing industries worldwide.

With customers in over 150 countries, and serving industries as diverse as food, pharmaceuticals, cosmetics, luboils and petrochemicals, Silverson has become the world leader in the field of high shear mixing. Time after time, companies specify Silverson mixers as the “standard” equipment for their manufacturing process.

The key to this success is based on the professionalism and commitment Silverson shows to each of its customer’s needs. Whether supplying machines from its standard range of mixers or designing equipment specifically to meet an individual customer’s requirements, quality is guaranteed.

With a customer base that includes many of the world’s largest companies, Silverson is constantly at the forefront of new technologies. Developing and applying new high shear mixing techniques to meet these needs, Silverson has the experience, knowledge and commitment to both quality and service to solve today’s mixing needs and those of the future.

A truly international company, Silverson is represented by a network of associated companies, distributors and agents in over 50 countries, serving Europe, North America, Asia, Australasia, South America and Africa.



Why Silverson?

Speed

The exceptionally rapid Silverson mixing action substantially reduces process times compared with conventional agitators and mixers and can reduce mixing times by up to 90%.

Versatility

The advantage of the Silverson approach to mixing is that any one machine can perform the duties that in the past may have required several different pieces of process equipment.

This unrivalled versatility allows any machine to perform the widest range of mixing applications:

- **Blending** - A homogeneous product is rapidly produced when blending liquids of similar or greatly varying viscosities, eliminating problems such as stratification.
- **Emulsifying and homogenising** - Emulsions (typically in the range of 0.5 to 5 microns) can be easily achieved.
- **Disintegration** - All Silverson rotor/stator mixers can disintegrate matter of animal, vegetable, mineral or synthetic origin in a single operation.
- **Particle size reduction** - Uniformly mill both solid and semi-solid materials into either solution or fine suspension.
- **Gelling and solubilising** - The high shear action of the Silverson rotor/stator can rapidly disperse gums, alginates, CMC, carbopols, etc., resulting in an agglomerate-free solution within minutes.

Flashmix

Powder/Liquid Mixer

The Silverson Flashmix takes a revolutionary approach to powder/liquid mixing. Unlike many powder/liquid mixers, which use vacuum to pull in powders, the Flashmix literally forces powder into the liquid stream.

This not only allows it to disperse and hydrate large volumes of powders, it means it can be used at higher temperatures and with higher viscosity mixes - offering the advantages of high shear mixing to a wide range of applications that were previously not possible.

The range features 3 production mixers and a laboratory model (see page 15).

Powder Incorporation Rate of up to
15,000 kilos/hour

Advantages

- Powder incorporation rates of up to 15,000 kilos/hour
- Agglomerate-free, consistent product, time after time
- Suitable for operation at higher temperature
- Suitable for higher concentrations of gums and thickeners
- Minimum aeration
- Modular construction with a range of options to suit requirements
- Hygienic design - based on an EHEDG and 3-A Certified mixer
- Low power requirement; no additional pump required
- Low level, ergonomic design
- The Flashmix is easy to install, easy to operate and easy to clean



How the Flashmix Works

Stage 1

The specially modified Silverson In-Line mixer recirculates liquid from the process vessel through the Flashmix at high velocity.

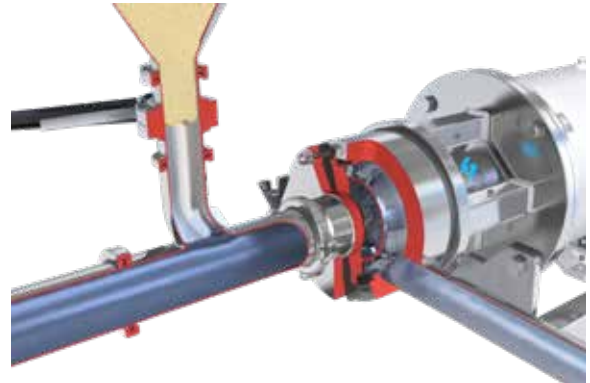

Stage 2

The powder feed valve is opened, and the high pumping action of the In-Line mixer forces the powder into the liquid stream.

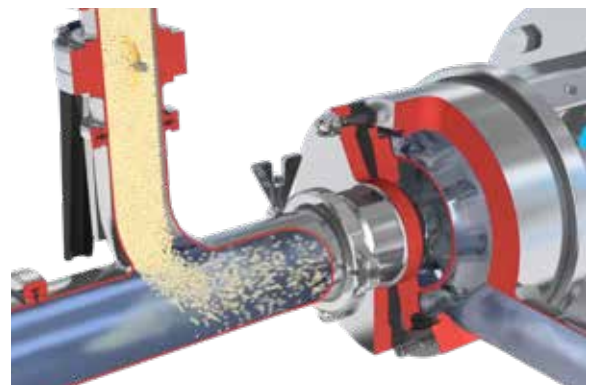

Stage 3

The powder and liquid components are introduced straight into the high shear zone of the mixer, and are instantaneously combined as they are subjected to intense mechanical and hydraulic shear. The resultant mix is passed back to the vessel by the self-pumping Flashmix.

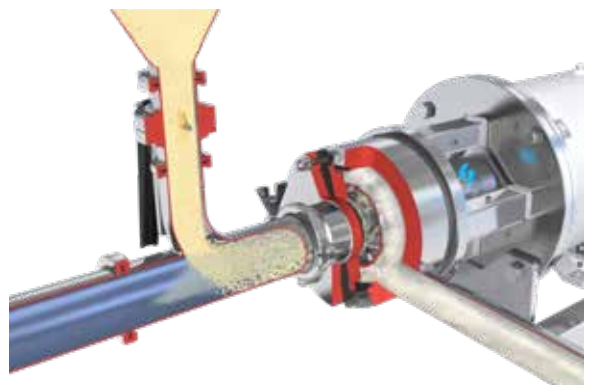

Performance

Typical liquid flow and powder incorporation rates are as follows:

Model	Liquid Flow (tonnes/hour)	Gums & Thickeners	Milk Proteins	Sugars
FMX25	20	600	1,700	1,000
FMX50	40	1,100	7,000	3,500
FMX75	90	2,600	14,000	10,000

*Powder incorporation rates shown are in kilos/hour and are for guidance only

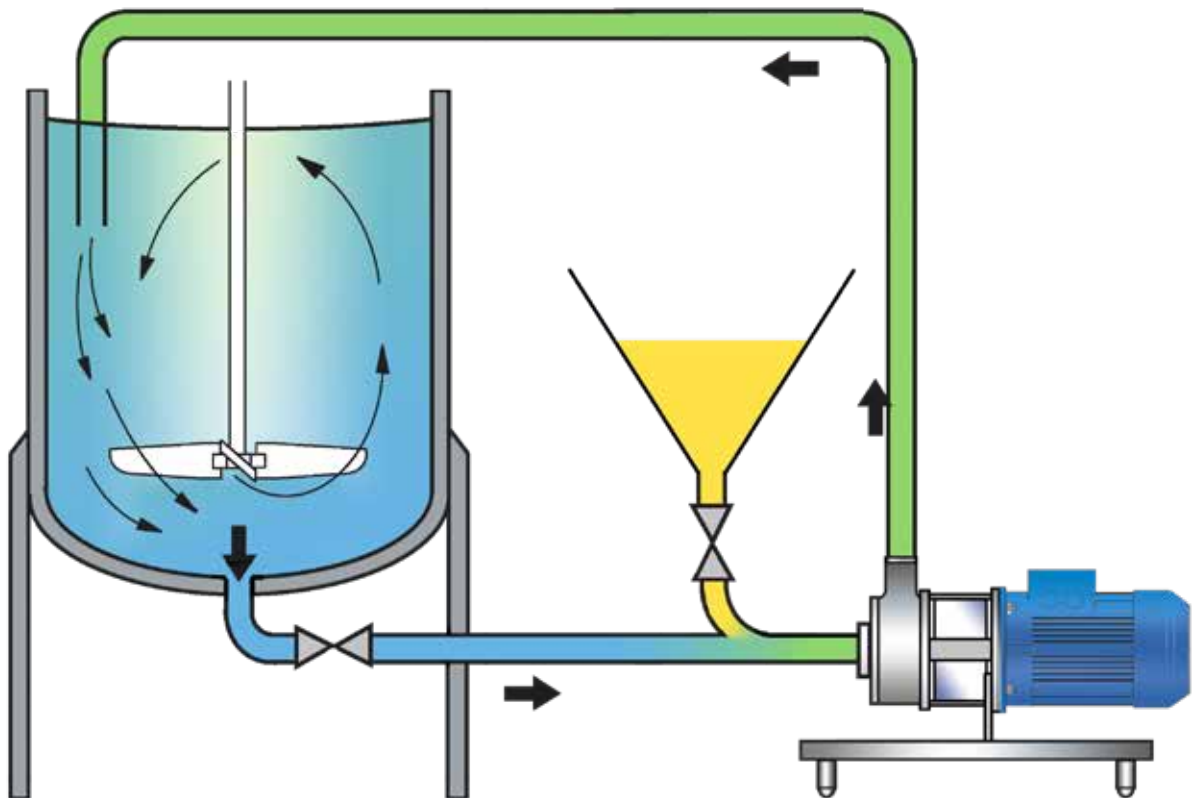

Operation

The Flashmix is designed for use in a recirculation system as shown above. Powder is rapidly incorporated by the self-pumping Flashmix, and a brief period of recirculation results in an agglomerate-free, homogeneous dispersion.

An auxiliary in-tank mixer or agitator will normally be required to maintain uniformity in the process vessel.

Technical Specifications

Materials of Construction

	Standard Unit	Chemical Duty
Wetted Parts: 316L Stainless	●	●
Wetted Parts: Special Materials	○	○
Chassis: 304 Stainless	●	●
Elastomers: Viton	●	●
Elastomers: Other	○	○
Operating Pressure	150 psi (10 bar)	150 psi (10 bar)

Motor

TEFC	●	●
Other - Stainless, Flameproof/ATEX	○	○

Inlet/Outlet Connections

Tri-Clamp	●	○
Flange	○	●
Other e.g., RJT, SMS, etc.	○	○

Sealing

Single Mechanical		●
Double Mechanical		○
Ultra-Hygienic Single/Double Mechanical	●	

Powder Feed

Manual Butterfly Valve	●	●
Other e.g., Manual Ball Valve, Pneumatic, etc.	○	○
Powder Feed Suction Hose	○	○

● Standard ○ Optional



FMX25 with 40 litre hopper



Sack table option



FMX50 with 100 litre profiled hopper



Powder feed suction hose



FMX75 with 300 litre profiled hopper

Flashblend Powder/Liquid Mixing System

The Silverson Flashblend is designed to incorporate large volumes of powders on a continuous and semi-continuous basis, at rates of up to 15,000 kilos/hour. The semi-automated system can be specified for ultra-hygienic applications and custom built to suit clients' specific requirements. There are over 500 Flashblend systems in use worldwide, throughout all sectors of the process industry.



Technical Specifications

Materials of Construction

	FLB 30	FLB 60
Wetted Parts: 316L Stainless	●	●
Wetted Parts: Special Materials	○	○
Chassis: 304 Stainless	●	●
Elastomers: Viton	●	●
Elastomers: Other	○	○

Motor

TEFC	●	●
Other - Stainless, Flameproof/ATEX	○	○

● Standard ○ Optional

Inlet/Outlet Connections

	FLB 30	FLB 60
Tri-Clamp	●	●
Other e.g., RJT, SMS, etc.	○	○

Sealing

Single Mechanical	●	●
Double Mechanical	○	○

Powder Feed

Pneumatic Butterfly Valve	●	●
Hopper	100L	300L

Operating Sequence

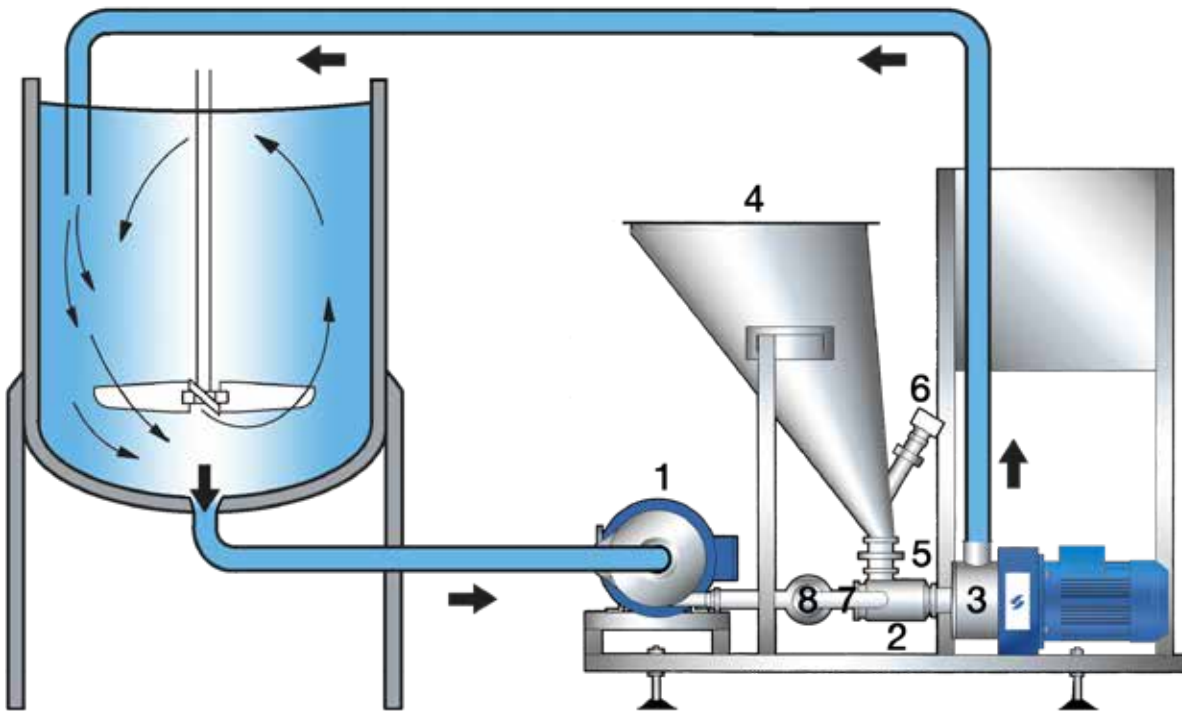

Operation

Liquid is forced through the system by the pump (1). The liquid flow through the venturi assembly (2) creates a vacuum, boosted by the pumping action of the Silverson In-Line mixer (3). When powder is present in the hopper (4), the valve (5) can be opened and powder is drawn down into the venturi by the vacuum.

The powder/liquid mix immediately passes into the high shear rotor/stator assembly of the Silverson In-Line mixer, ensuring a finely dispersed and agglomerate-free mixture. The resultant product is passed back to the process vessel by the pumping action of the machine.

Once the hopper is empty, the sensor (6) will automatically shut the valve, minimising aeration. When the powder sensor closes the powder feed valve, product flow can be diverted round a bypass line (7) by the diverter valve (8). The high flowrate in this mode ensures a scouring action of the venturi housing, keeping the area free of any build-up of partially hydrated powder. The bypass position is also used for Cleaning-In-Place (CIP), ensuring that the venturi area is cleaned to as high a standard as normal hygienic piping.

Advantages

- Suitable for large scale production
- Repeatability
- Can be incorporated into automated systems
- Speed
- Fully sterilisable units available
- Minimum aeration
- Can be customised to suit client requirements
- Improved vessel hygiene
- Agglomerate-free product

Silverson Service

Experience and Know-How

Silverson has been the leader in High Shear Mixing technology for over 75 years and has built up a detailed knowledge of mixing process requirements. This accumulated knowledge enables our technical staff and sales representatives to clearly identify a client's needs and recommend the type of mixer most suited to provide an efficient and economical solution.

Extensive Test Facilities

Available for the use of all clients, Silverson operates dedicated test facilities equipped with a wide range of laboratory and production scale machines where customers may test new products and discuss their applications with our technical staff. If preferred, Silverson mixers can be provided for on-site trials to allow evaluation under actual production conditions.

Customisation

Increasingly today's process manufacturers require equipment to be designed to meet their own particular needs. Silverson has a positive approach and flexibility which allows mixers to be custom designed and built to suit individual users' specific requirements.

Worldwide Support

A truly international company, Silverson is represented by a network of associated companies, distributors and agents in over 50 countries, serving Europe, North America, Asia, Australasia, South America and Africa.

Installation

Silverson offers expert advice and, if required, can assist with and supervise installation and start up.

After-sales service

With over 75 years of experience, Silverson realises the importance their customers place on reliable and rapid back-up service. Our large stock of manufactured parts enables us to despatch most standard spares the same day they are ordered.

Some of Our Clients



These trademarks & company logos are included with the kind permission of the owners.

United Kingdom Corporate Headquarters

Silverson Machines Ltd.
Waterside, Chesham
Buckinghamshire HP5 1PQ
England
Tel: +44 (0) 1494 786331
Email: sales@silverson.co.uk

United States

Silverson Machines, Inc.
355 Chestnut Street
East Longmeadow, MA 01028
Tel: +1 (413) 525-4825
Email: sales@silverson.com

France

Silverson France
12 Boulevard Louise Michel
91030 EVRY CEDEX
France
Tel: +33 (0) 1 60 77 91 92
Email: info@silverson.fr

Japan

Silverson Nippon Limited
Onohara Higashi 4-22-3
Mino Osaka Japan
Zip code 562-0031
Tel: +81-72-734-8003
Email: sales@silverson.co.jp



www.silverson.com

Silverson® is a registered trademark of Silverson Machines.
Square Hole High Shear Screen™ is a trademark of Silverson Machines.
Patent Pending.