

BRIDGES ♦ BOARDWALKS ♦ JETTIES

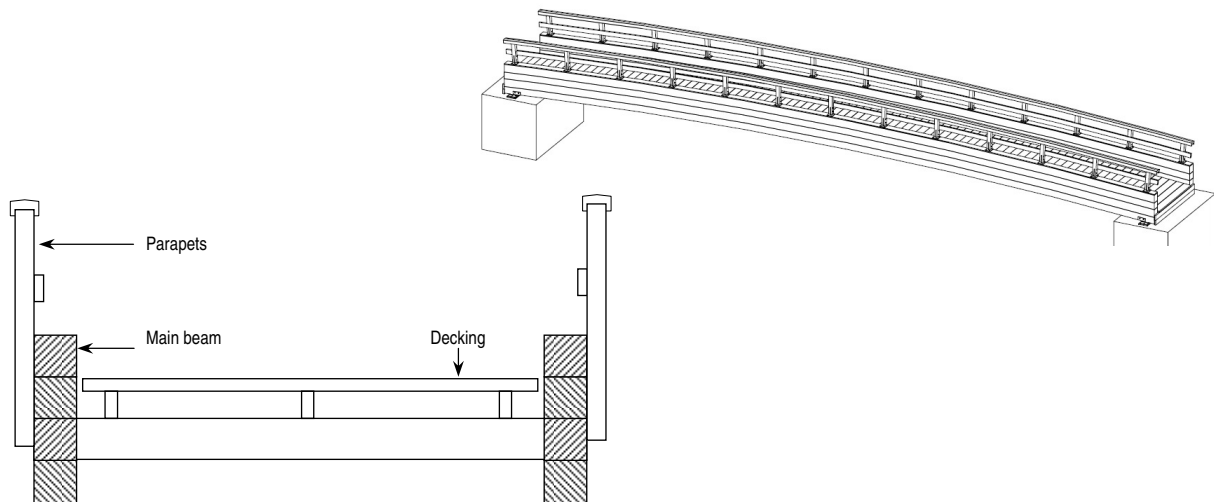

Total support from concept to installation
Designs and options to blend in with the environment
Constructed with natural hardwood



TYPE 2 THROUGH DECK LAMINATED HARDWOOD BEAMS

Where depth of construction is a limiting factor, then an SHS bridge with a through deck construction could be the solution.

Mechanically laminated main beams

Developed for spans up to 25 m

Reduced depth of construction

Designed to accommodate pedestrians & equestrian users

OPTIONS INCLUDE

Choice of parapets

Parapets can be mounted on the side or the top face of the main beams

Can be produced with a bow

Grooved slip resistant decking with optional anti-slip resin bonded aggregate inserts or surface coating

Design can incorporate other architectural materials to influence the aesthetic appearance

THE BENEFITS OF HARDWOOD

No preservative treatment required

Minimal maintenance

Excellent vandal resistance & fire retardant characteristics

Parapets

STYLES & OPTIONS

The parapet plays an important part in the aesthetic value of the bridge. Depending on the situation and purpose, a choice is made for either horizontal or vertical parapets. SHS offers a range of standard hardwood parapets and also welcomes the opportunity to quote for the design and supply of bespoke parapets in both hardwood and metal.

SHS STANDARD HARDWOOD PARAPETS

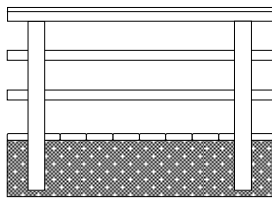

Type A parapet
Handrail + 2 intermediate rails

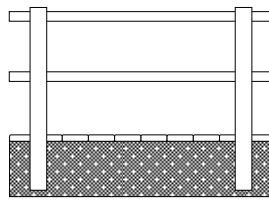

Type B parapet
2 x intermediate rails

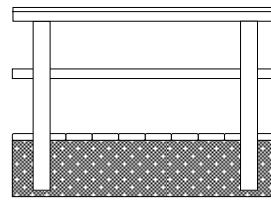

Type C parapet
Handrail + 1 intermediate rail

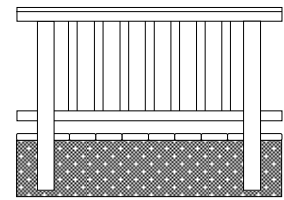

Type E parapet
Handrail + vertical infill rails

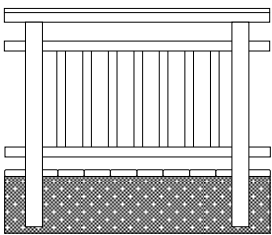

Type EE parapet
Elevated handrail + vertical infill rails

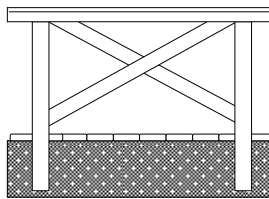

Type G parapet
Handrail + cross rails

TYPICAL HARDWOOD SECTION SIZES

- Posts 95 x 95 mm
- Hand rail 95 x 145 mm
- Intermediate rails 40 x 115 mm
- Vertical infill rails 40 x 40 mm

TYPICAL PARAPET HEIGHTS

- Pedestrian 1.15 m
- Cycleway 1.40 m
- Equestrian 1.80 m

Anti-slip decking

ANTI-SLIP OPTIONS

Walking surfaces are usually formed from timber decking, which has a grooved slip resistant finish. This resistance can be enhanced by introducing either our factory fitted anti-slip GL Insert or our factory applied anti-slip GL Coating, to the deck surface.

Anti-slip GL options are constructed from particles of aggregates embedded within a modified resin compound. When the compound is cured the resultant finish is a very hard wearing surface with high slip resistant characteristics, suitable for timber decks used in a multitude of locations.

Whichever option you choose, be it the GL Inserts or the GL Coating the resultant finish is an effective, hard wearing surface that complements the aesthetic appearance of the timber and is the ideal solution for anti-slip safety on an SHS bridge, boardwalk or jetty.

TYPICAL DECK FIXING

40 mm thick decking

- 8 mm Ø x 90 mm long screws
- 8 mm Ø x 90 mm long dowels

28 mm thick decking

- 5 mm Ø x 60 mm long screws

