

STERLING

Sterling Aluminium Extraction System (AES)

The AES is designed for use as a small centralised extractor. It works very well for prep room applications, where a central extractor collects waste from a variety of work shop machines, such as aluminium up-cut saws and small routers which require a compact high performing extractor without demand for large filter areas.

The AES has been well tried and tested over many years in a range of applications. It has tubular filters which allow for the release of coarse waste and it is accompanied by a large 150L waste collected bin.

The design is flexible and allows for the cabinet to be easily turned to suit its final destination. The inlet/motor plates can also be swapped over to allow the inlet to be located on either top side or the underside of the extractor.



Machine Features

- High performance and very compact
- Low cost
- Filters that work well with coarse wastes
- Large collection capacity for use with coarse or bulk wastes
- Available with a number of optional extras
- Tried and tested in both education and industry over many years
- 4 x main tubular filter and an after filter available in a number of filter grades (G4 is standard)

Optional Features

The AES can also be ordered with a variety of optional extras, including:

- ATEX Explosion Relief
- Auto-Shake Filter Cleaning
- 'Quiet' Arrangement which includes an enclosed base with lockable doors
- Loc Line Kit which provides extraction at the front of the blade.
- Clean Up Kit with 80mm Vacuum Hose, clean up nozzle & holster + connections

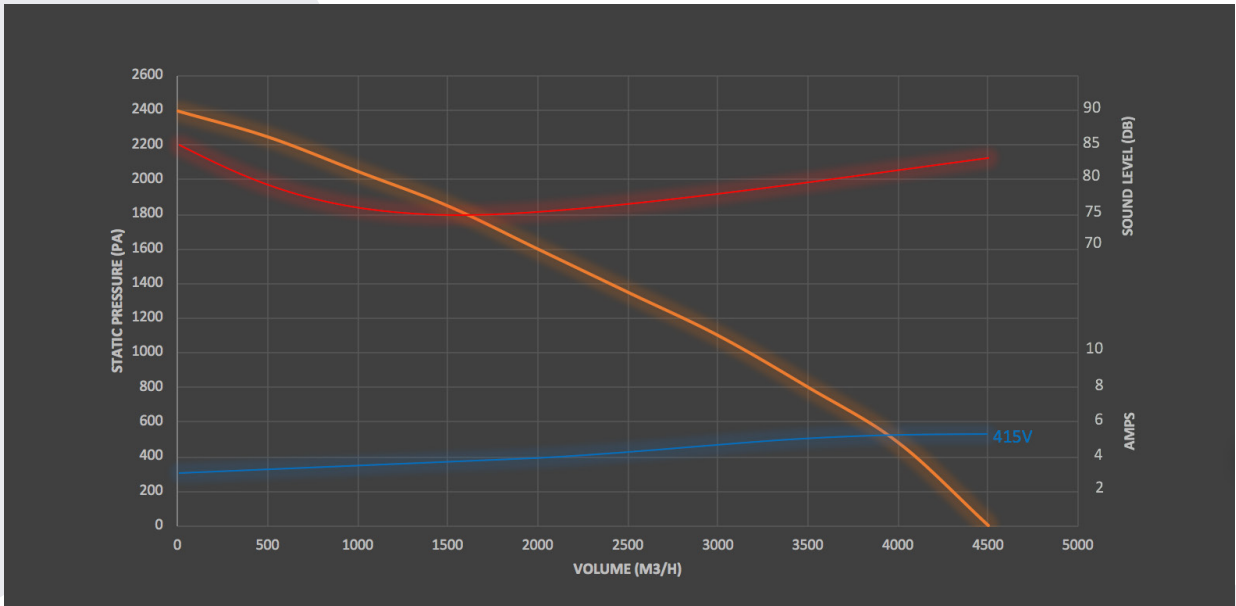

PERFORMANCE

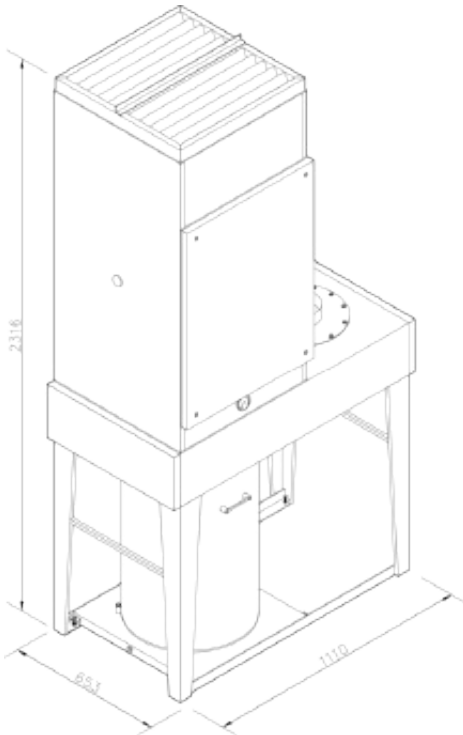

EXTRACTION UNIT MEASUREMENTS



AES - SHOWN FITTED

TECHNICAL SPECIFICATIONS

MODEL	Sterling Aluminium Extraction system
Fan Motor	2.2 kW – 2 pole – 415v 3 Phase – 5.1A or 1 Phase – 14 A
Filters	4 x Tubular Terylene Needle Felt
Filter Area	4.09 m ² (44ft ²)
Filter Cleaning	Manual Agitation
Explosion Area	Bulk Bin + Bin Liner
Operation	Top of Cabinet/Vent Area
Fan Inlet	225 mm Dia.