

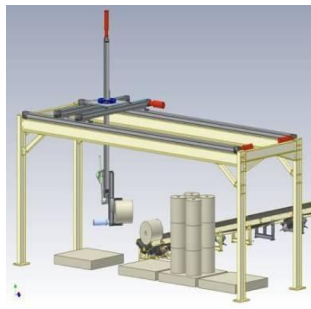

Within SCM there is a great deal of expertise in relation to flexible packaging materials handling, which is one of the company's core business specialist areas.

Our equipment is designed and built in the UK at our headquarters in Taunton, and is manufactured to a heavy-duty construction and to the highest standards.



SCM provide winder unload equipment, conveyors, transfer and up-ender units, automatic labelling, wrapping, palletising and robotic pick and place systems, bionic arm manipulators and reel turning units.



SCM have recently moved into a brand new building, which will enable increased equipment manufacturing capability.



SCM Materials Handling Ltd
Broadgauge House
Broadgauge Business Park
Westridge Way
Bishops Lydeard
Taunton
Somerset
TA4 3RU

Tele – 01823 431 838
Fax – 01823 430 806

Contacts :

- Mr Jon Boulton – Managing Director
- Mr Alan Griffiths – Sales Manager

We offer free, no obligation consultation visits, to assist with any materials handling projects

Please view our web site for company – full product range information

www.scmhandling.com