

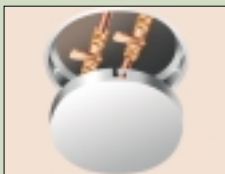

Panelcraft Access Panels

CI/SfB	(35.3)	Xh
CI/SfB	(32.7)	Xh2(K2)
CI/SfB	(32.8)	Xh
CI/SfB	(37.5)	Xh

4th Edition

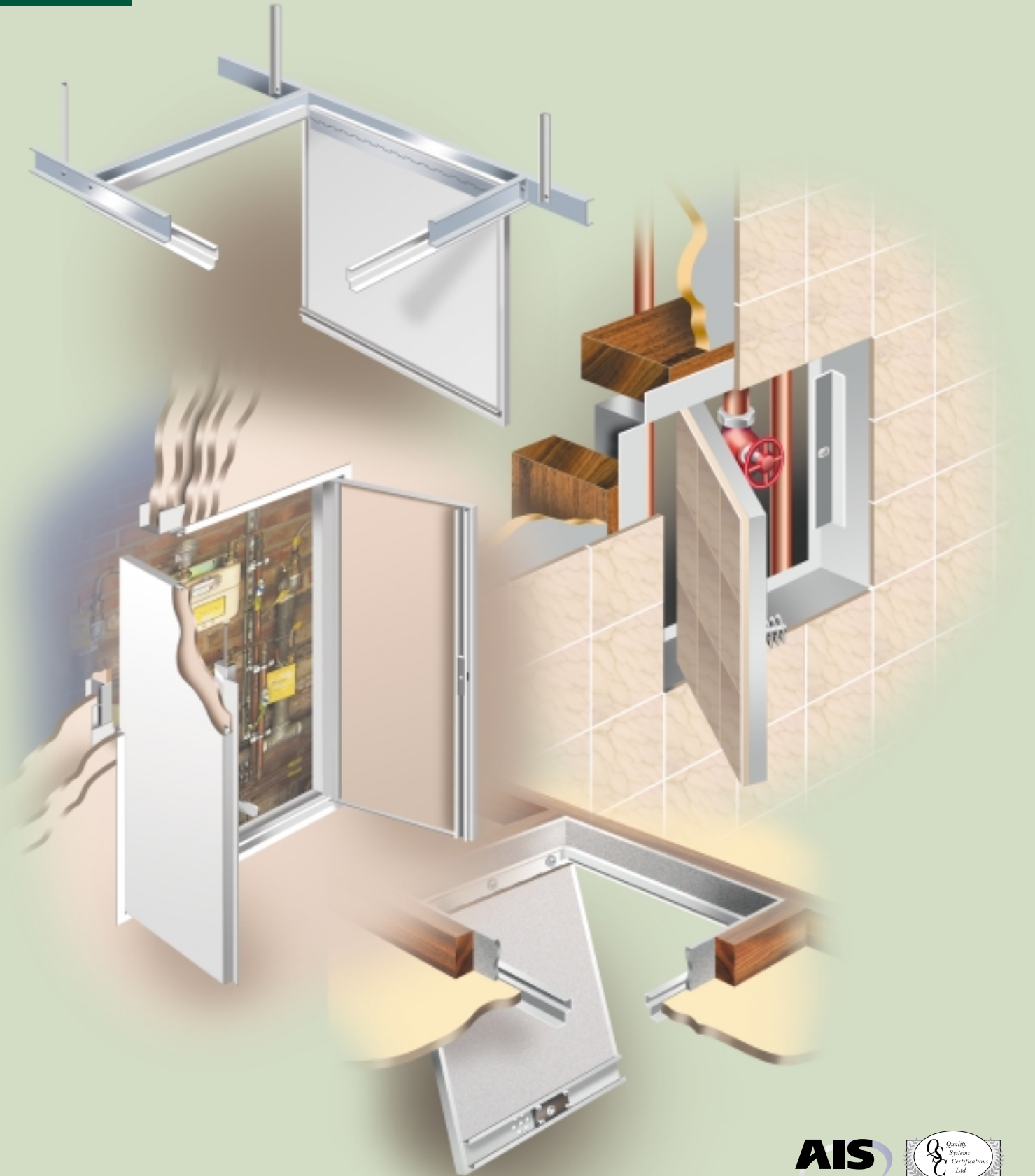

AIS
Association of
Interior Specialists





Underestimated or overlooked access requirements can prove highly disruptive should they need to be addressed at a later stage. The use of stud partition cavities in dry lining, to carry services and address concealed controls, is now a vital and fundamental part of the architectural design process.

Panelcraft personnel pioneered the concept of manufacturing functional access panels that are aesthetic in design by blending into the surrounding surface. By working closely with architects, designers and builders we can provide the most appropriate solutions.

Research and development is constantly taking place to improve designs and offer new products. We can provide solutions to new methods of construction and we are constantly improving our designs to offer higher specifications – particularly in the area of Fire Resistance and Acoustics.

We implement quality management methods to ISO 9002. Panels are monitored throughout the production process with back office procedures in place to guarantee quality that delivers on time.

contents

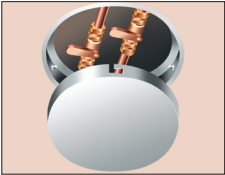

Discpan
pages 4-5

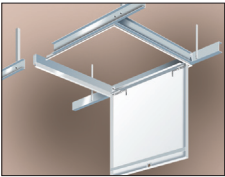

Slimpan
pages 6-7

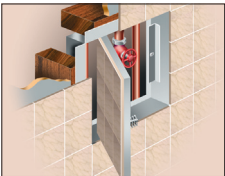

Tilepan
pages 8-9

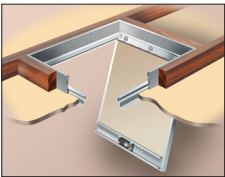

Loftpan
pages 10-11

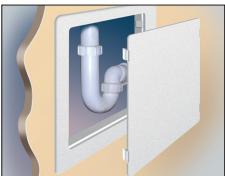

Plasticpan
pages 12-13

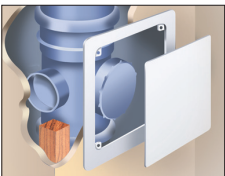

Magneticpan
pages 14-15

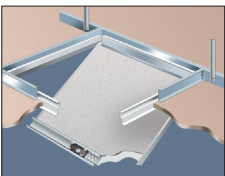

Firepan
pages 16-17

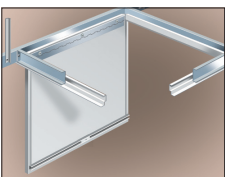

Tradpan
pages 18-19

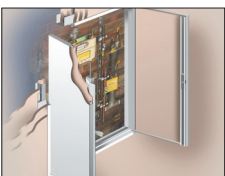

Firepan Magna
pages 20-21

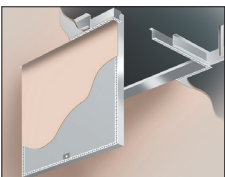

Plastapan
pages 22-23

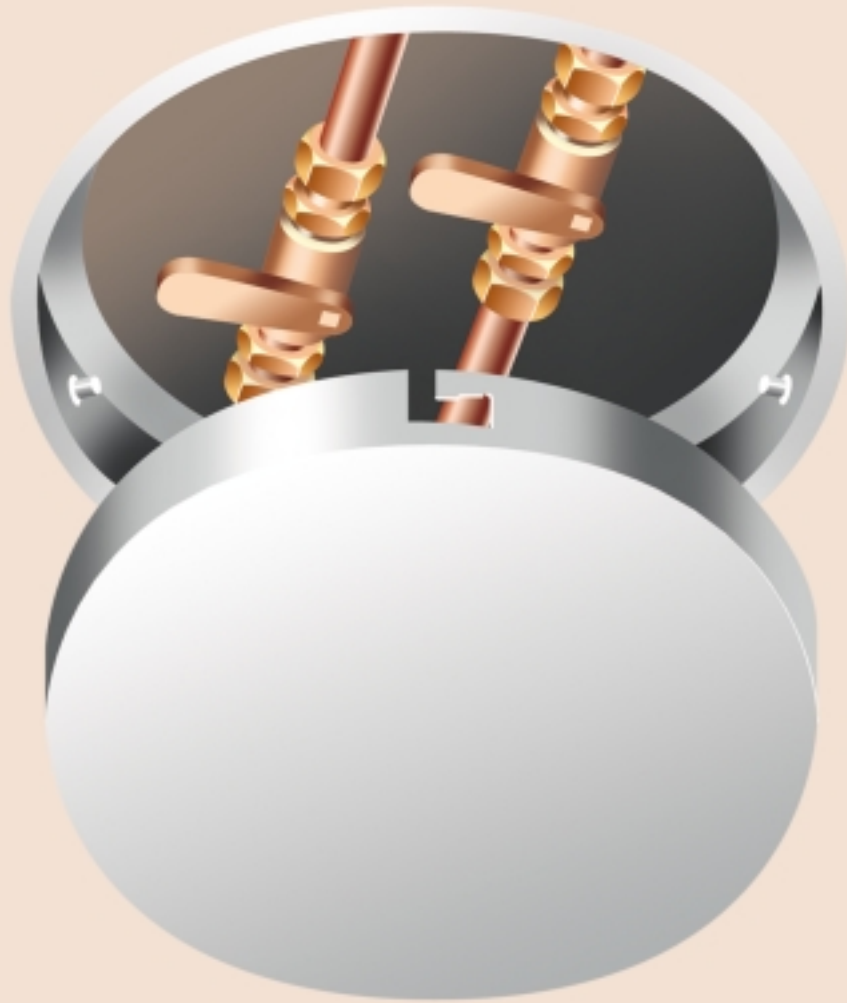

Discpan PF Discpan SBF

PANELCRAFT ACCESS PANELS have developed the DISCPAN RANGE to complement circular light fittings, speakers, smoke detectors and air grilles fitted in the ceiling, thereby maintaining an aesthetic appearance, whilst providing a cost effective solution for access to building engineering services concealed in the ceiling void.

Availability

Standard sizes EX STOCK for Next Day Delivery

Standard Sizes

Diameter
300mm
450mm
600mm

NOTE Add 15mm to above sizes for structural opening

- ❖ Non-fire rated
- ❖ Designed for ceilings only
- ❖ 35mm overall depth
- ❖ Precision manufactured in Zintec. Aluminium panels are available to order.
- ❖ Visible picture frame (PF) or simulated beaded frame (SBF) for taping and jointing to conceal the frame.
- ❖ Supplied powder coated RAL 9010 20% gloss as standard
- ❖ No on site manufacturing costs
- ❖ Easily installed in minutes straight from the box
- ❖ Suitable for on-site decoration to match the surrounding areas if required
- ❖ Door easily removed without the use of tools

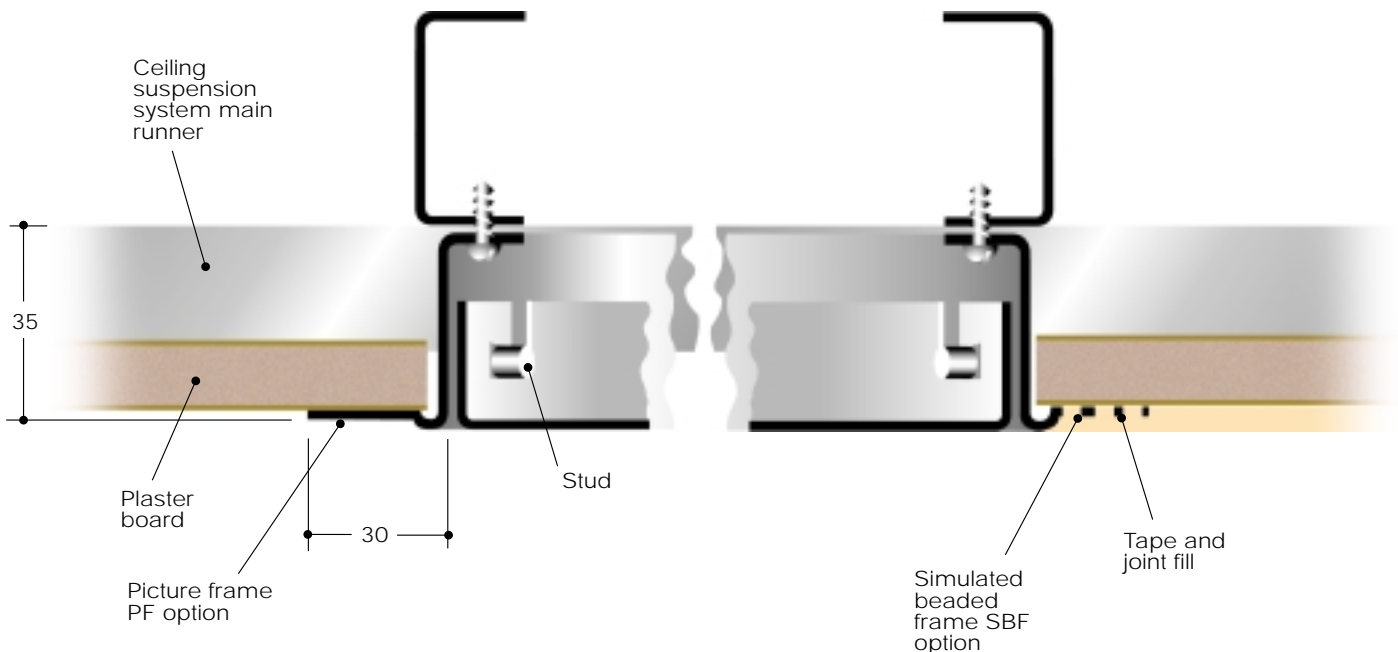



Slimpan

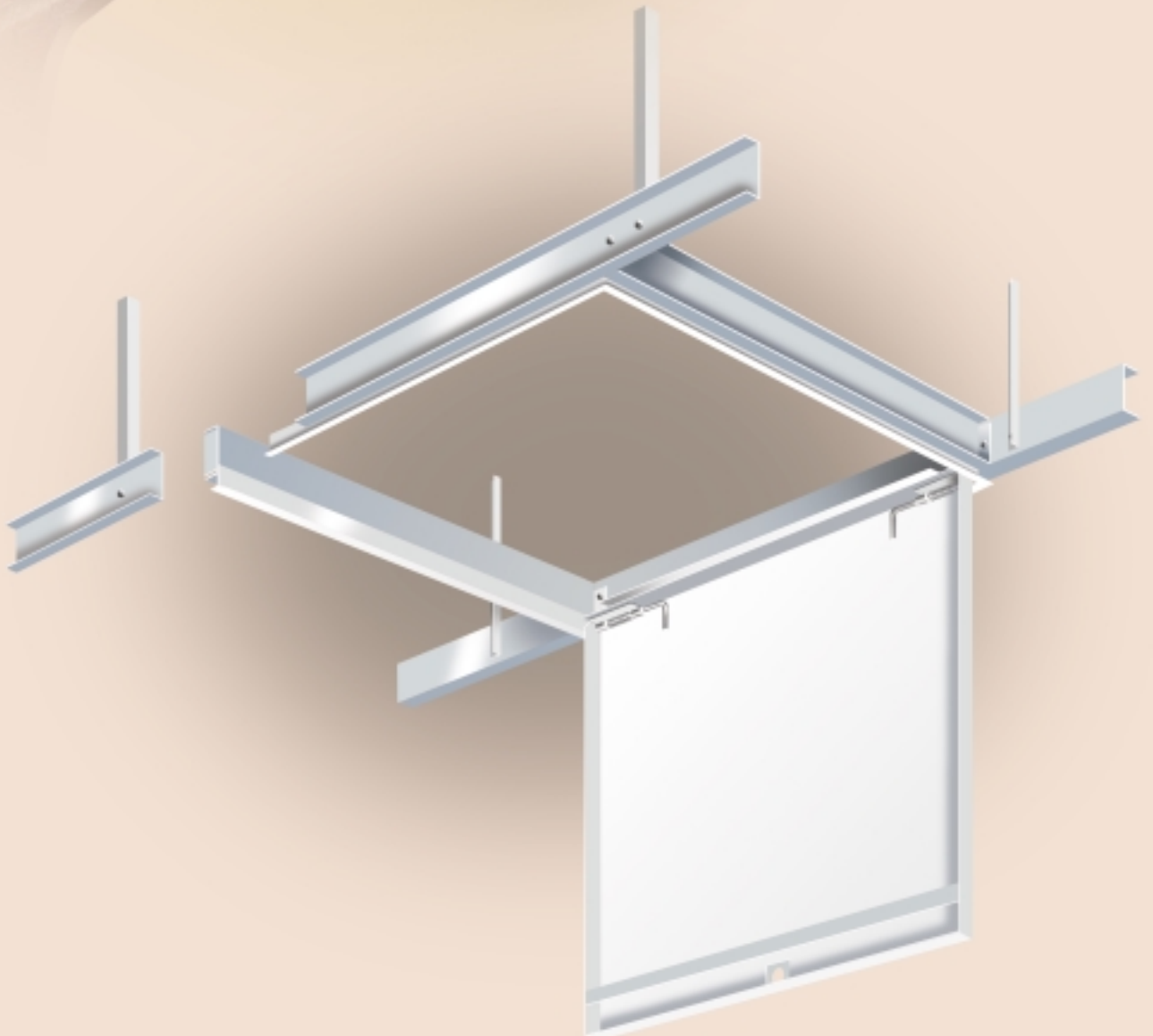

Slimpan PF Slimpan SBF

PANELCRAFT ACCESS PANELS have developed the SLIMPAN RANGE to provide a cost effective solution for access to building engineering services concealed in wall cavities or ceiling voids where the depth of frame is critical.

Availability

Available only in standard sizes
EX STOCK for Next Day Delivery

Standard Sizes

H	W	H	W
200	x 200	550	x 550*
300	x 300	600	x 300
450	x 450	600	x 600

*To fit between 600mm centre studs

NOTE Add 15mm to above sizes for structural opening

- ❖ Non-fire rated.
- ❖ 25mm overall depth, allowing insulation where space is limited
- ❖ Versatile panel suitable for walls and ceilings avoiding confusion when ordering or fitting on site
- ❖ Precision manufactured in Zintec
- ❖ Visible picture frame (PF) or simulated beaded frame (SBF) for taping and jointing to conceal the frame.
- ❖ Supplied powder coated RAL 9010 20% gloss as standard
- ❖ Budget lock as standard
- ❖ No on site manufacturing costs
- ❖ Easily installed in minutes straight from the box
- ❖ Suitable for on-site decoration to match the surrounding areas if required
- ❖ Door easily removed

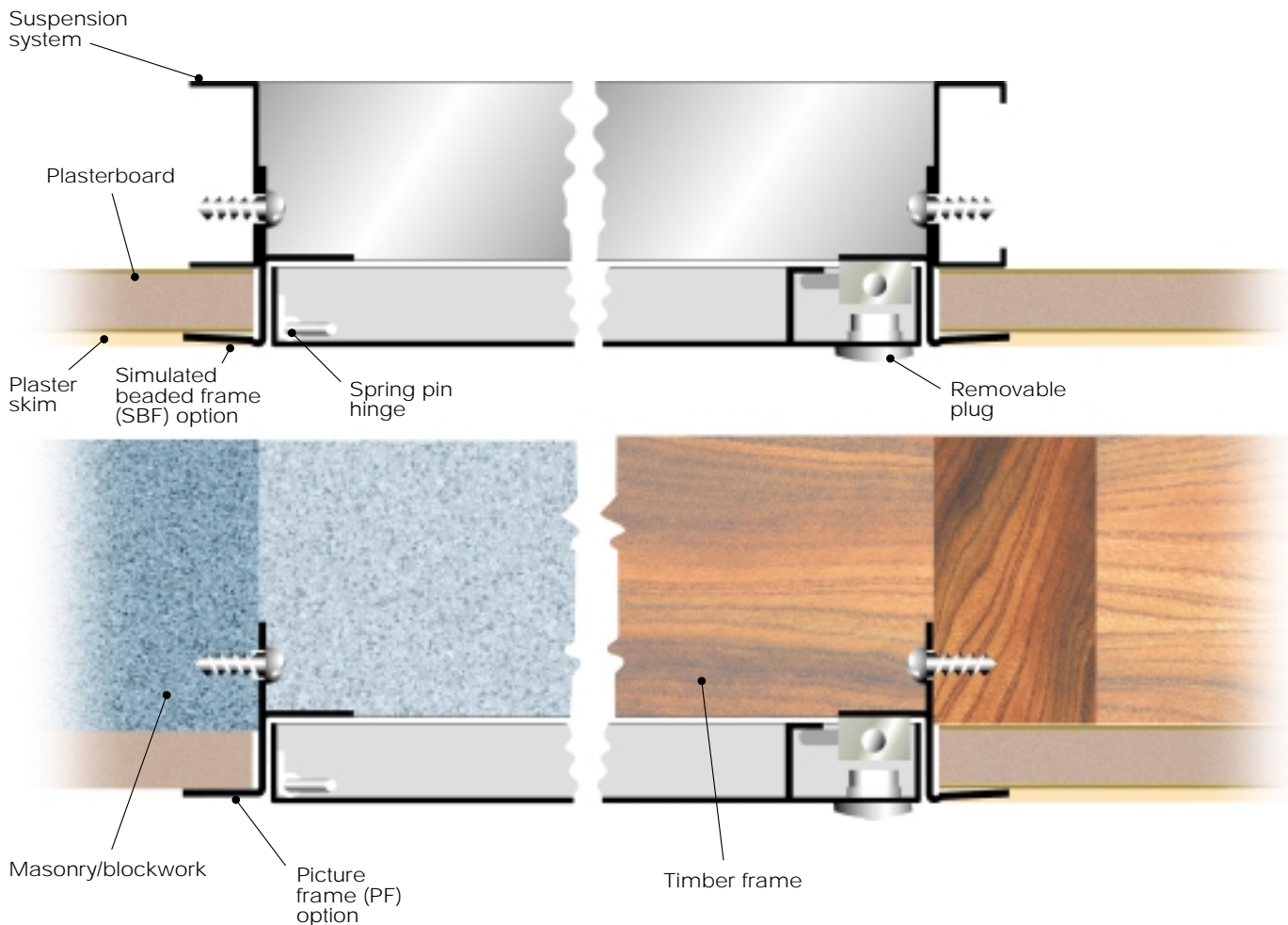

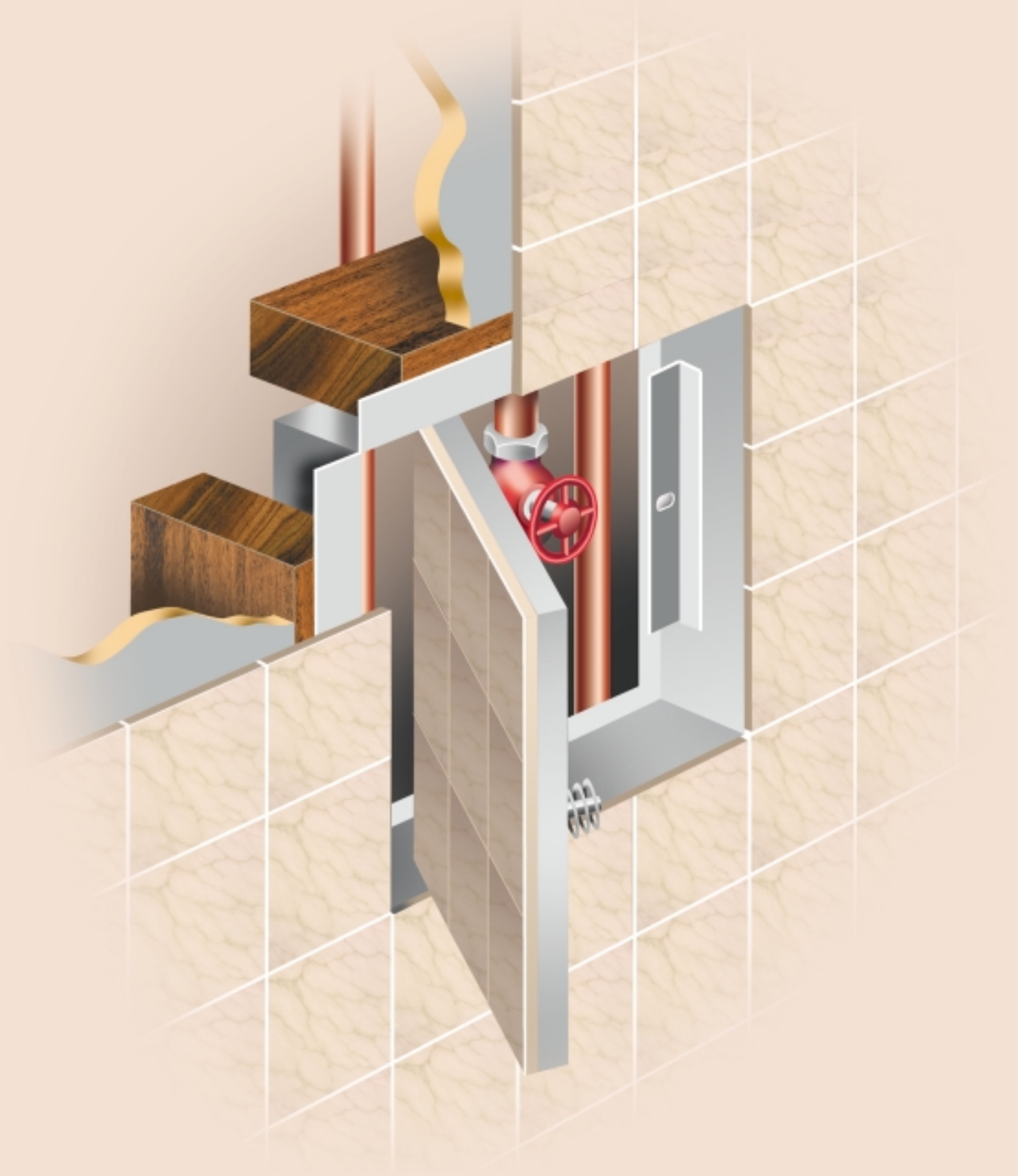

Tilepan

PANELCRAFT ACCESS PANELS have developed the TILEPAN RANGE to provide an effective solution to gain access to building engineering services concealed in ceramic, marble or slate tiled wall cavities.

Availability

As panels are made to suit individual requirements clear instructions are vital before manufacture can commence.

Panelcraft requires the following information

Width of door comprises of No. of tiles and tile width + grout line width.

Height of door comprises of No. of tiles and tile height + grout line width.

NOTE Add 23mm to above sizes for structural opening

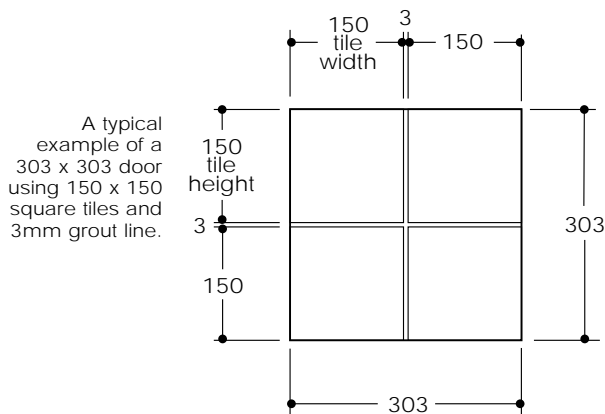

- ❖ Totally invisible
- ❖ Deflection no more than 1mm when open
- ❖ Fire Rated and Non-Fire Rated
- ❖ Designed for walls only
- ❖ Custom made to suit tile module
- ❖ Only 55mm overall depth excluding tiles
- ❖ Precision manufactured in Zintec.
- ❖ Concealed frame fixed into the wall prior to tiling
- ❖ Door faced with tiles on site up to 10mm thick to finish flush with surrounding tiles
- ❖ Supplied powder coated RAL 9010 20% gloss as standard
- ❖ Touch catch as standard
- ❖ Budget lock keylock or security lock options available depending on specification
- ❖ No on site manufacturing costs
- ❖ Easily installed in minutes straight from the box
- ❖ Door easily removed without use of tools

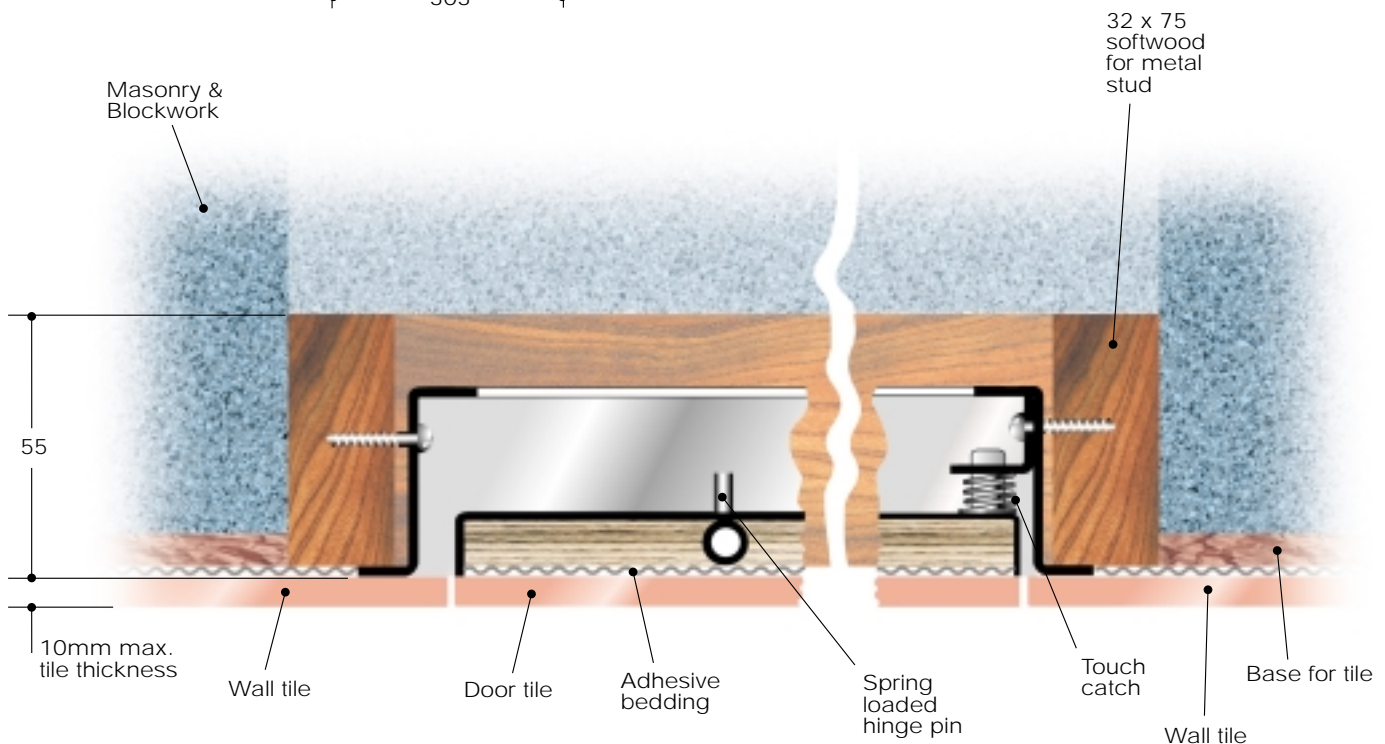

Loftpan

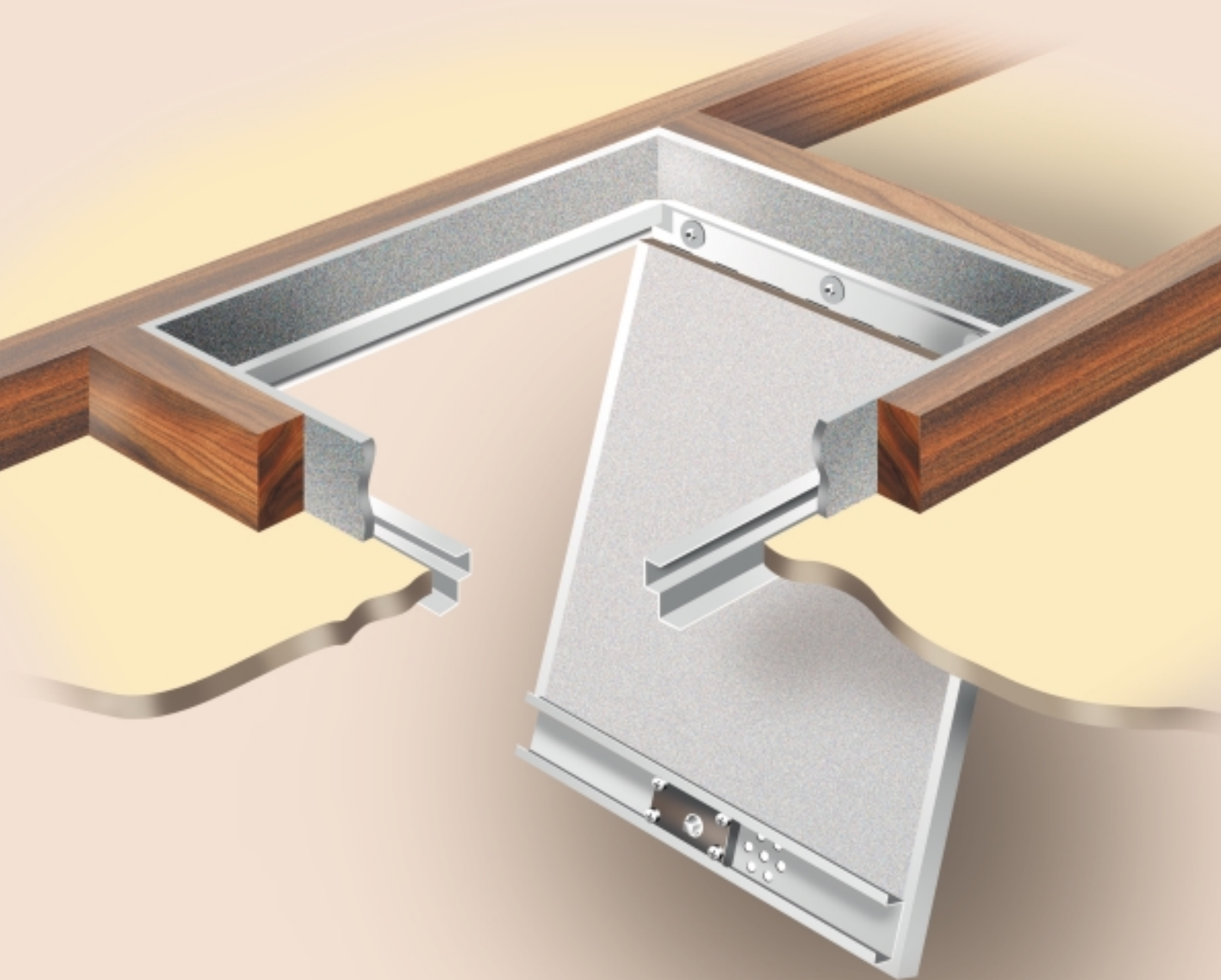

Loftpan PF60 Loftpan SBF60

PANELCRAFT ACCESS PANELS have developed the LOFTPAN RANGE to provide an effective solution to gain access to lofts and roof space

Availability

Standard sizes EX STOCK for Next Day Delivery

Standard Sizes

530mm (hinge side) x 745mm

- ❖ Fire Rated. And Non Fire Rated
- ❖ Provides 60min Fire Protection
- ❖ Conforms to Building Regulation Document L1 & L2 2002
- ❖ 50mm overall depth
- ❖ Fitted between max 47mm wide 600mm centre trusses or joists
- ❖ Precision manufactured in Zintec.
- ❖ Fully concealed full length heavy duty piano hinge
- ❖ Visible picture frame (PF) or simulated beaded frame (SBF) for taping and jointing to conceal the frame.
- ❖ Supplied powder coated RAL 9010 20% gloss as standard
- ❖ Slot Budget lock
- ❖ Keylock or security lock options available depending on specification
- ❖ Flap down door and hinged design allows for use with telescopic ladders (available on request)
- ❖ No on site manufacturing costs
- ❖ Easily installed in minutes straight from the box
- ❖ Suitable for on-site decoration to match the surrounding areas if required
- ❖ Door easily removed

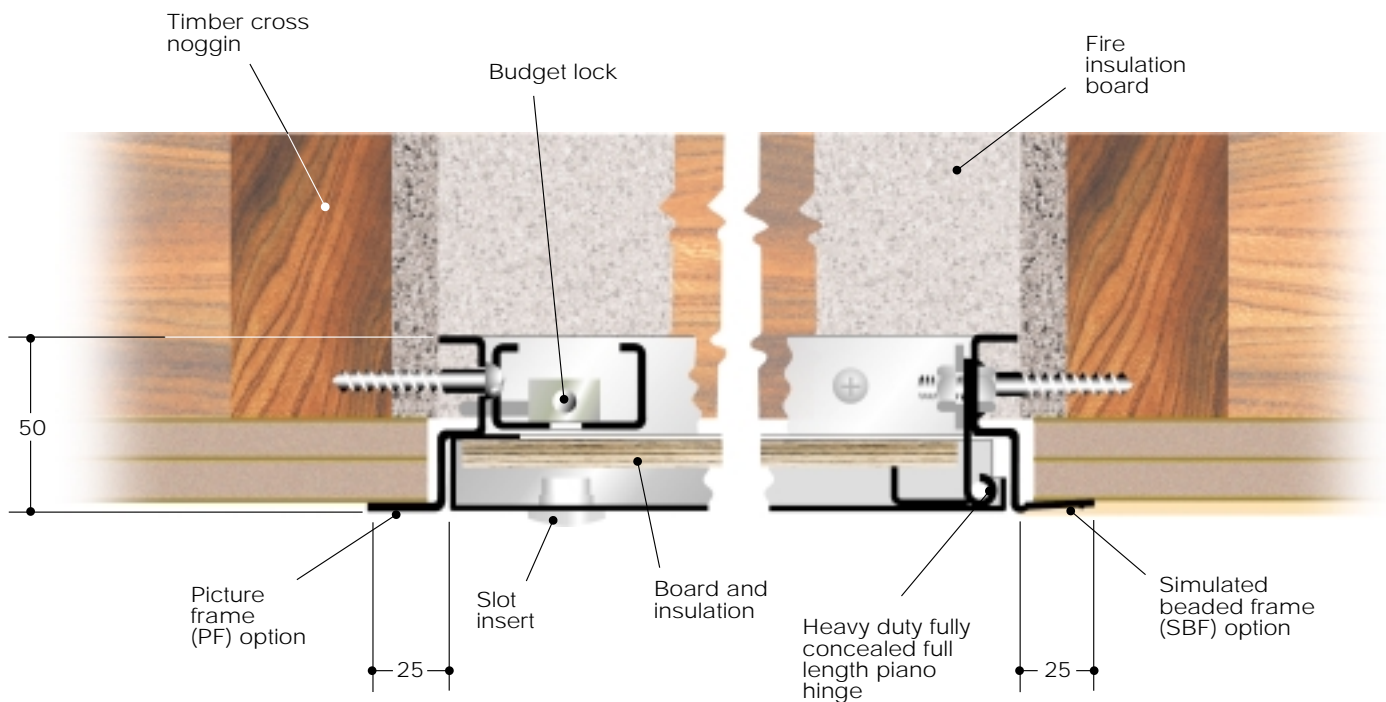



Plasticpan

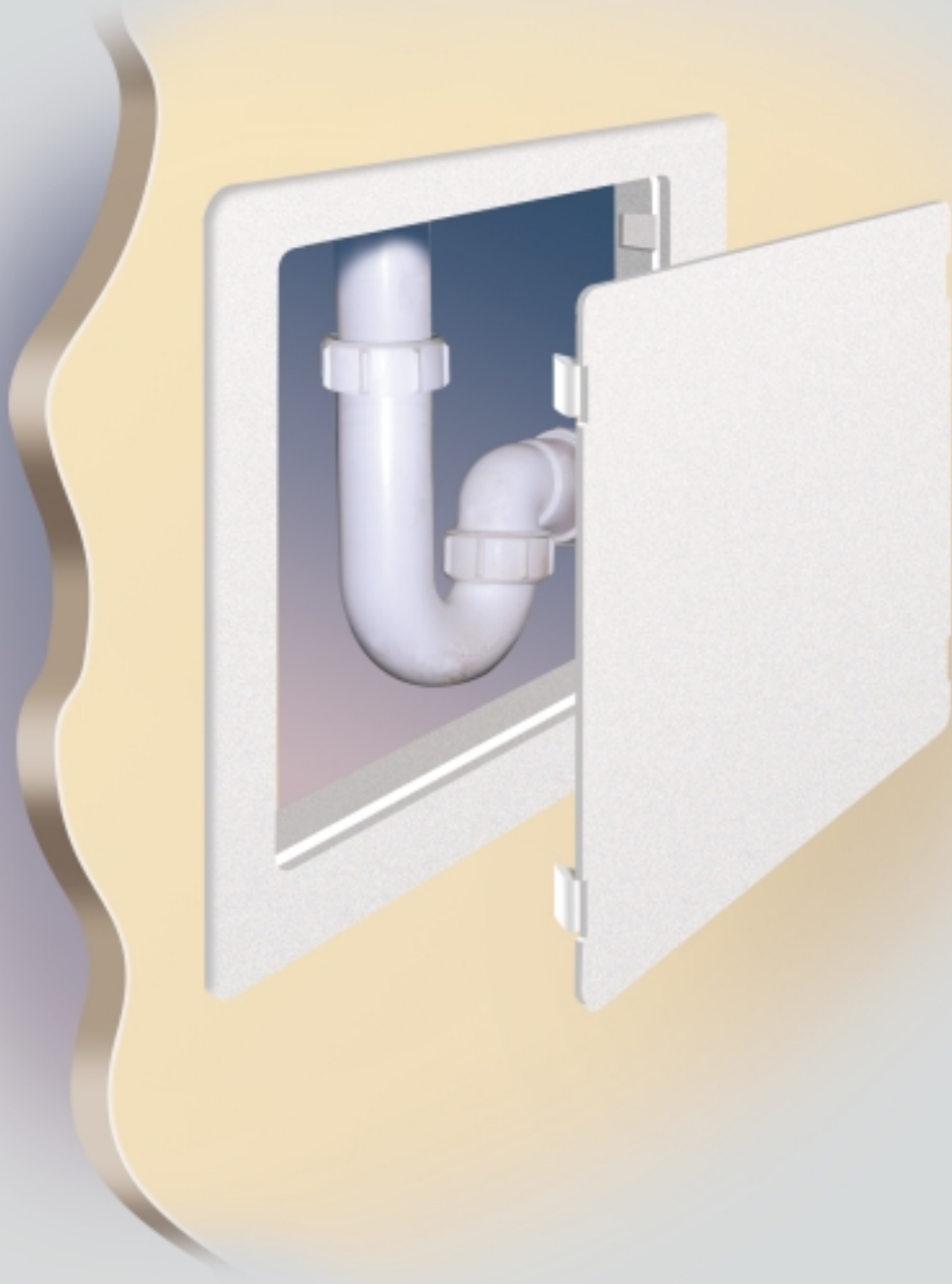

Plasticpan

PANELCRAFT ACCESS PANELS have developed the PLASTICPAN RANGE to provide a cost effective solution and versatile access to plumbing, electrical, gas, water installations etc eliminating costly wall and ceiling repair.

Availability

Available only in standard sizes
EX STOCK for Next Day Delivery

Standard Sizes

H	W
102 X	152
153 X	230
203 X	203
348 X	348
350 X	737

NOTE Add 15mm to above sizes for structural opening

- ❖ Non-fire rated.
- ❖ 21mm overall depth, allowing access where space is limited
- ❖ Versatile panel suitable for walls and ceilings avoiding confusion when ordering or fitting on site
- ❖ Made from precision moulded high impact non-corrosive ABS material
- ❖ Frame reversible for concealment
- ❖ No on site manufacturing costs
- ❖ Easily installation mounting allows for surface or flush mounting straight from the box
- ❖ No timber framing required
- ❖ Suitable for on-site decoration to match the surrounding areas if required
- ❖ Door easily removed
- ❖ Pop out cable entry points

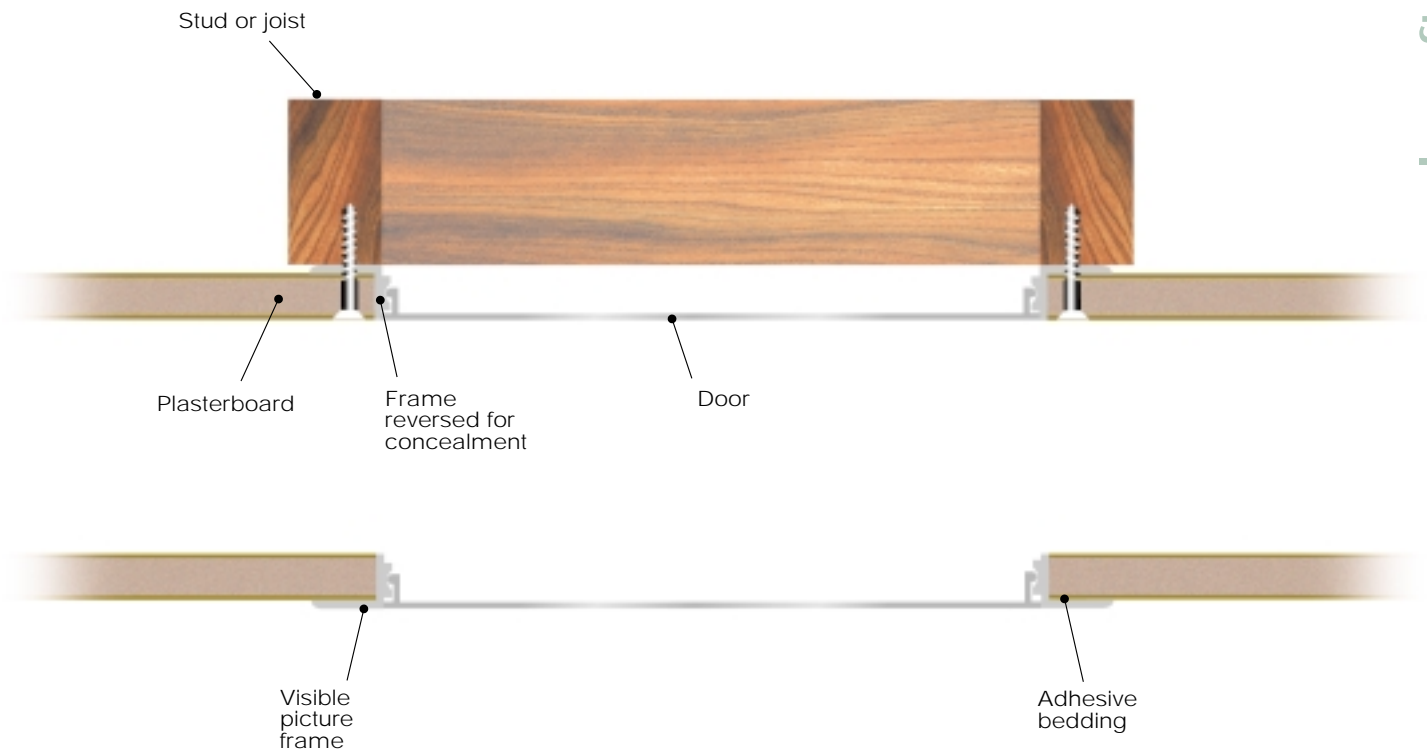



Magneticpan

**This product has been discontinued
and replaced by Plasticpan** (pages 12-13)

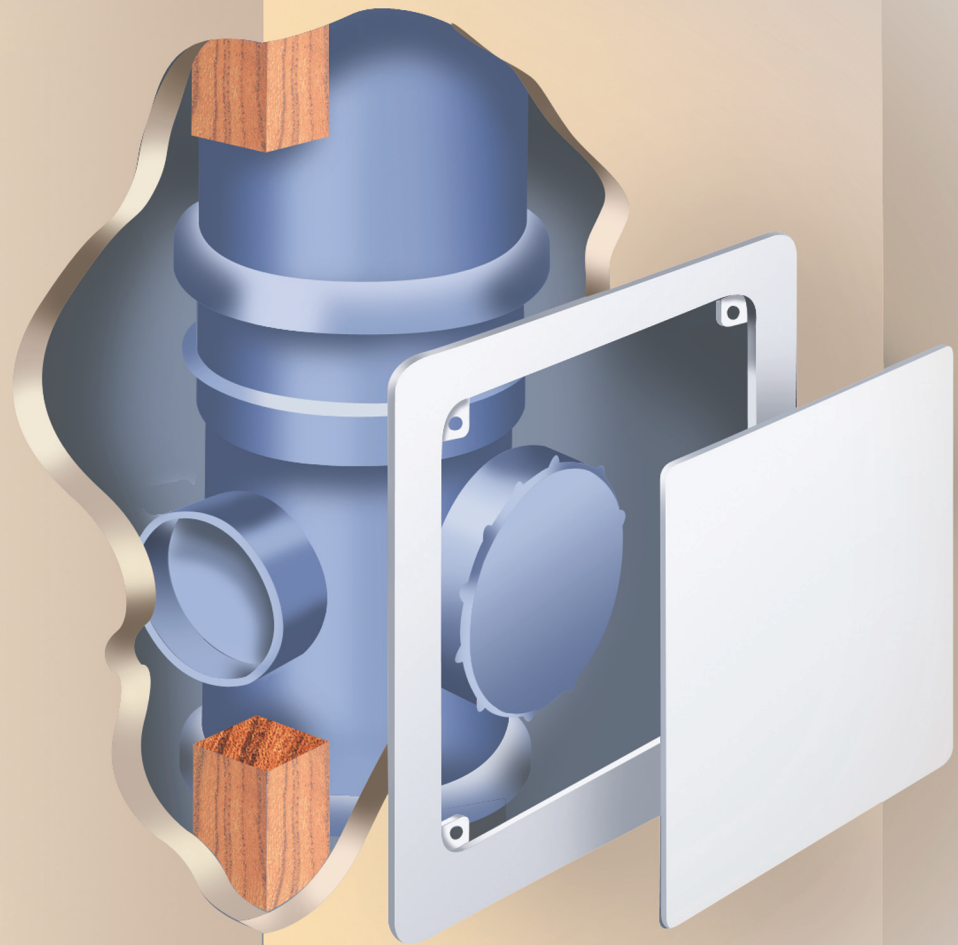

Magneticpan

PANELCRAFT ACCESS PANELS have developed the MAGNETICPAN RANGE to provide a cost effective solution and versatile access to plumbing, electrical, gas, and water installations within wall voids

Availability

Available in standard size 150 x 150 EX STOCK for Next Day Delivery

Sizes

Bespoke sizes made to order

- ❖ Non-fire rated
- ❖ Designed for walls only.
- ❖ Allows access where space is limit
- ❖ Precision manufactured in Zintec
- ❖ Picture frame
- ❖ No on site manufacturing costs
- ❖ Easily installation mounting allows for surface mounting straight from the box
- ❖ No timber framing required
- ❖ Suitable for on-site decoration to match the surrounding areas if required
- ❖ Door easily removed

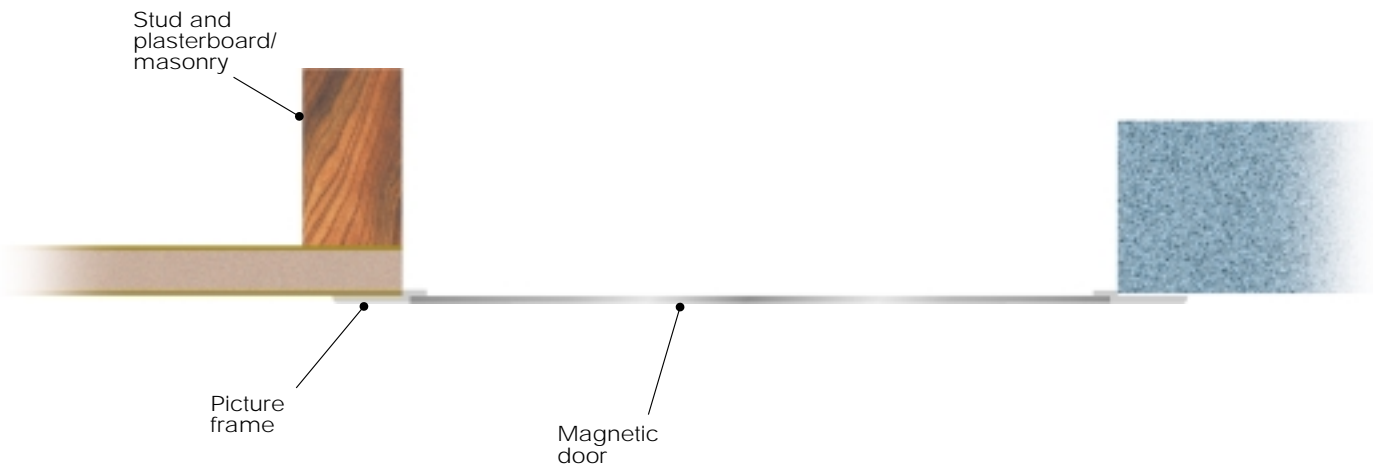



Firepan

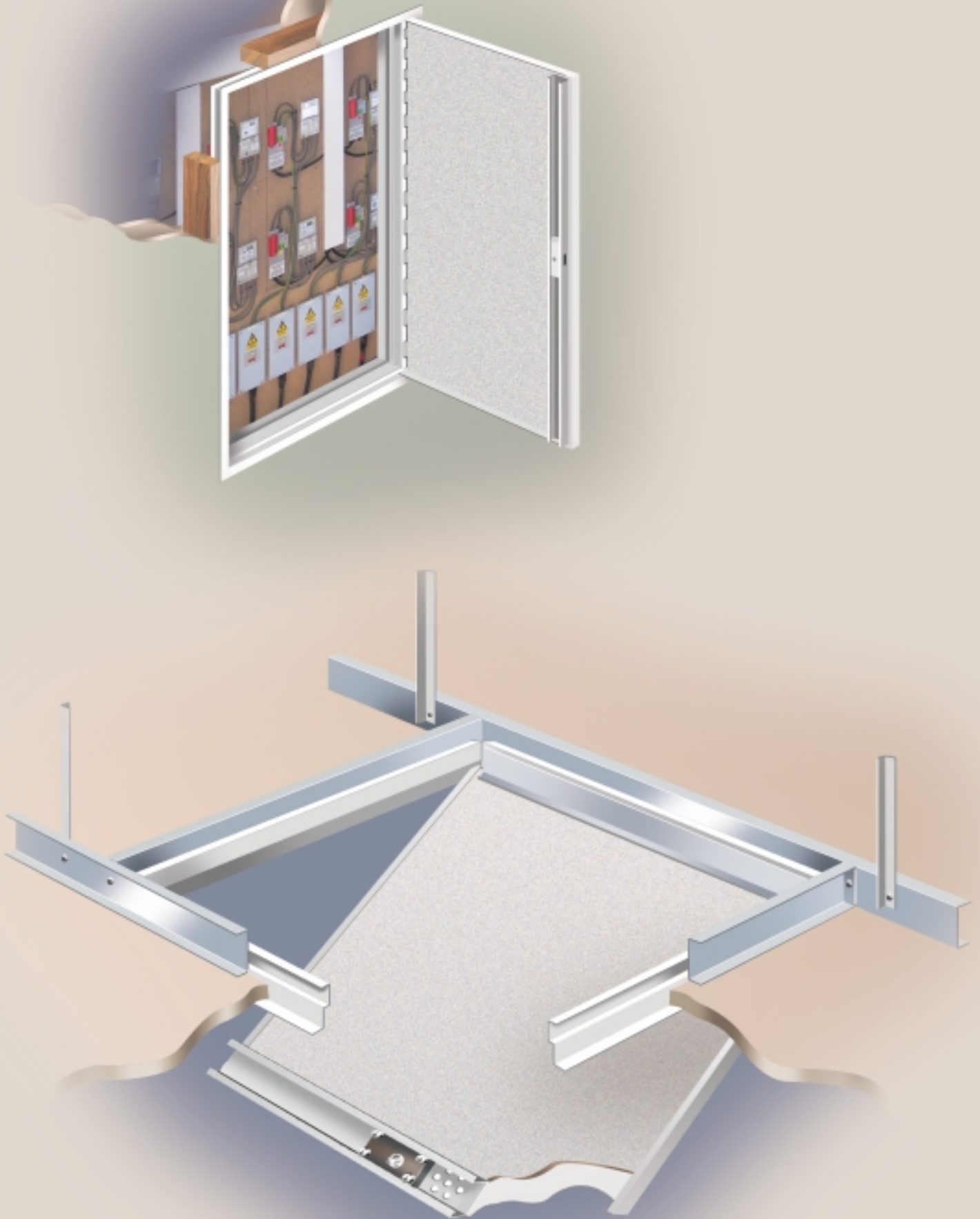

Firepan PF60 Firepan PF120 Firepan SBF60 Firepan SBF120

PANELCRAFT ACCESS PANELS have developed the TRADPAN RANGE to provide an effective solution to gain access to building engineering services concealed in drylined ceiling or wall structures which serve fire protection or separation purposes.

Availability

Standard sizes EX STOCK for
Next Day Delivery

BESPOKE SIZES MADE TO ORDER

Standard Sizes

H	W	H	W
200	x 200	600	x 600
300	x 300	800	x 800
450	x 450	900	x 550*
550	x 550*	1200	x 550*
600	x 300	2000	x 550*

*To fit between 600mm centre studs

NOTE Add 15mm to above sizes for structural opening

- ❖ Fire rated.
- ❖ Provides 30min. 60min or 120min Fire Protection for walls
- ❖ Provides 60min or 120min Fire Protection for ceilings.
- ❖ Provides 60min or 120min Fire Integrity from both sides for walls only
- ❖ Versatile panel suitable for walls and ceilings avoiding confusion when ordering or fitting on site
- ❖ 50mm overall depth
- ❖ Precision manufactured in Zintec.
- ❖ Fully concealed full length heavy duty piano hinge
- ❖ Visible picture frame (PF) or simulated beaded frame (SBF) for taping and jointing to conceal the frame.
- ❖ Supplied powder coated RAL 9010 20% gloss as standard
- ❖ Budget lock as standard
- ❖ Keylock or security lock options available depending on specification
- ❖ No on site manufacturing costs
- ❖ Easily installed in minutes straight from the box
- ❖ Suitable for on-site decoration to match the surrounding areas
- ❖ Door easily removed

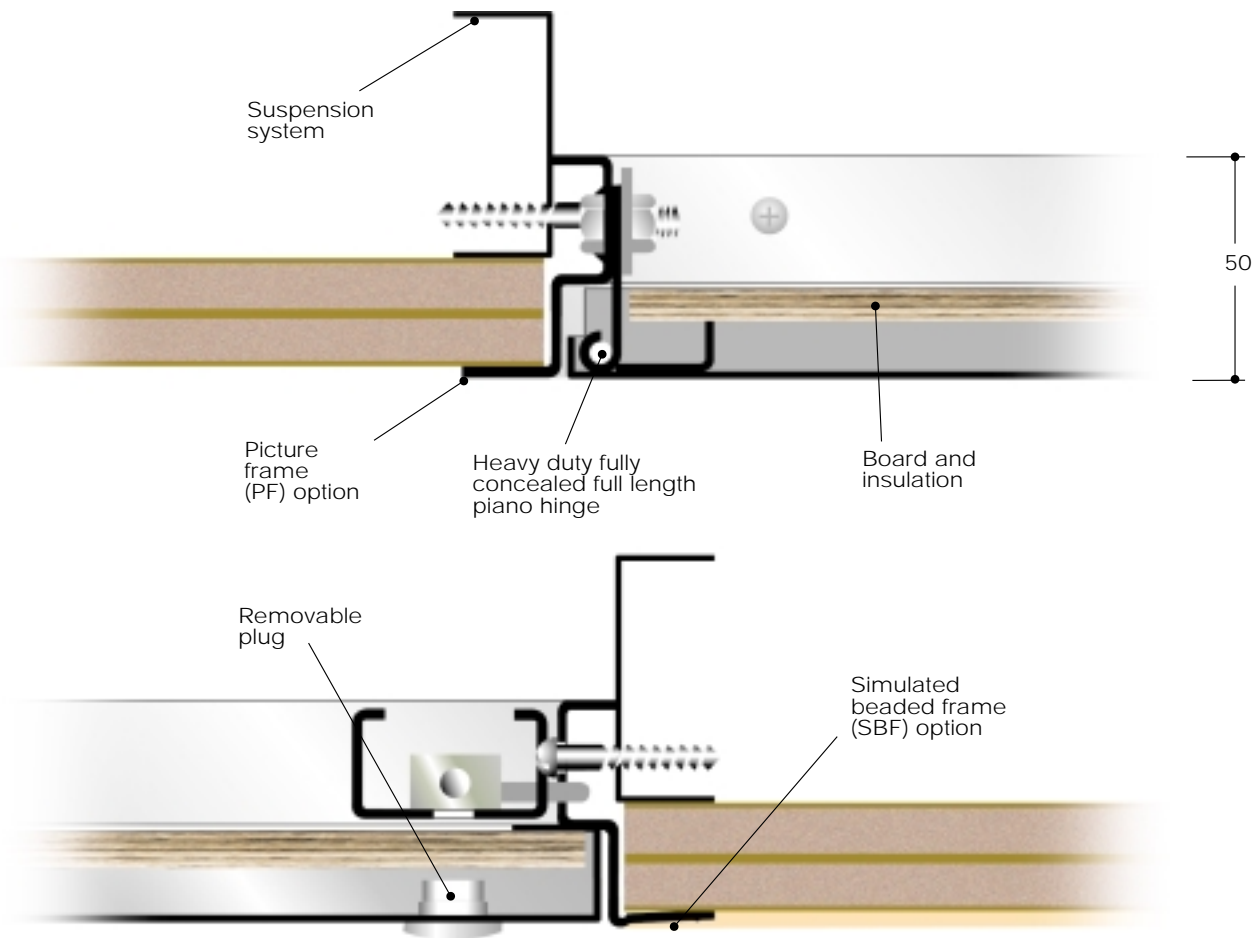



Tradpan

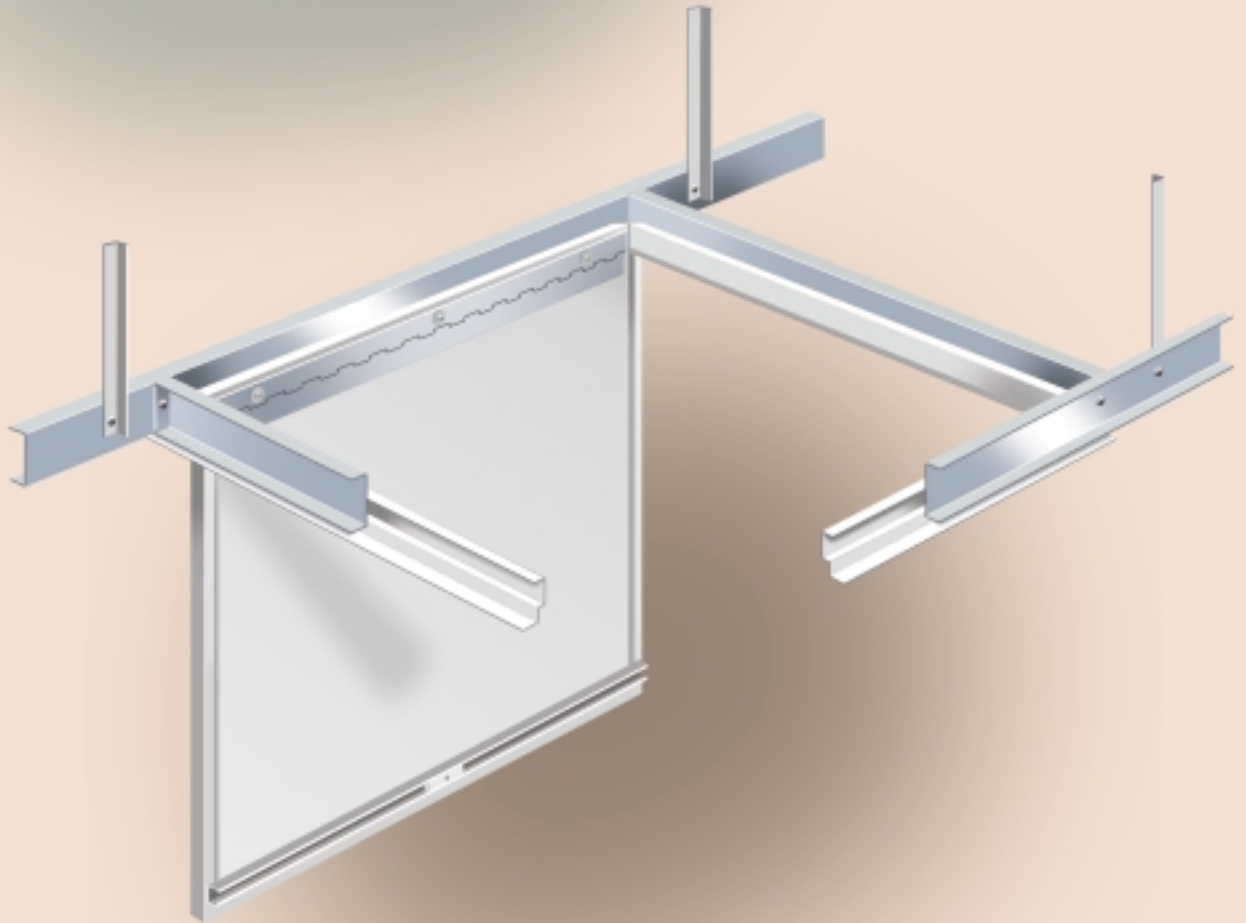

Tradpan PF Tradpan SBF

PANELCRAFT ACCESS PANELS have developed the TRADPAN RANGE to provide an effective solution to gain access to building engineering services concealed in wall cavities or ceiling voids.

Availability

Standard sizes EX STOCK for Next Day Delivery

BESPOKE SIZES MADE TO ORDER

Acoustic Panels and Air Handling Panels also available manufactured to suit specification.

Standard Sizes

H	W	H	W
200 x 200		600 x 600	
300 x 300		800 x 800	
450 x 450		900 x 550*	
550 x 550*		1200 x 550*	
600 x 300		2000 x 550*	

*To fit between 600mm centre studs

NOTE Add 15mm to above sizes for structural opening

- ❖ Non-fire rated.
- ❖ 50mm overall depth
- ❖ Versatile panel suitable for walls and ceilings avoiding confusion when ordering or fitting on site
- ❖ Precision manufactured in Zintec.
- ❖ Aluminium panels for high humidity areas available to order
- ❖ Fully concealed full length heavy duty piano hinge
- ❖ Visible picture frame (PF) or simulated beaded frame (SBF) for taping and jointing to conceal the frame.
- ❖ Supplied powder coated RAL 9010 20% gloss as standard
- ❖ Budget lock as standard
- ❖ Keylock or security lock options available depending on specification
- ❖ No on site manufacturing costs
- ❖ Easily installed in minutes straight from the box
- ❖ Suitable for on-site decoration to match the surrounding areas if required
- ❖ Door easily removed

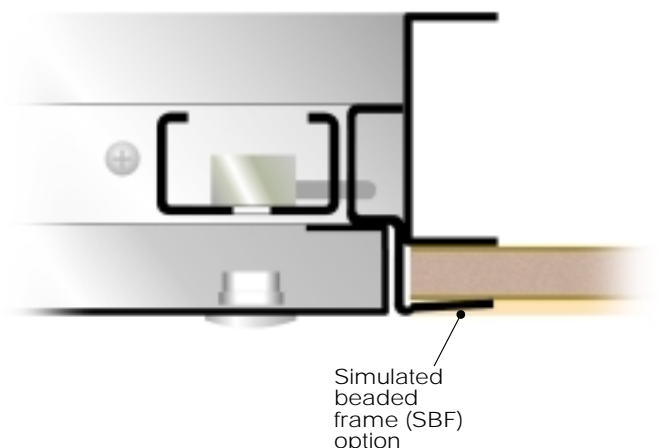
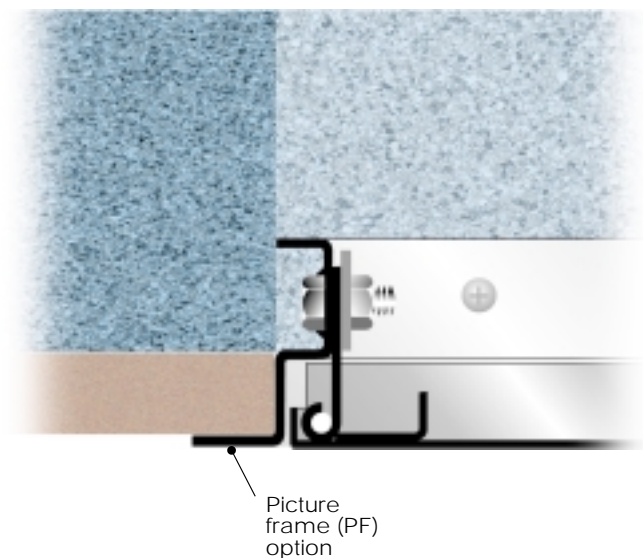
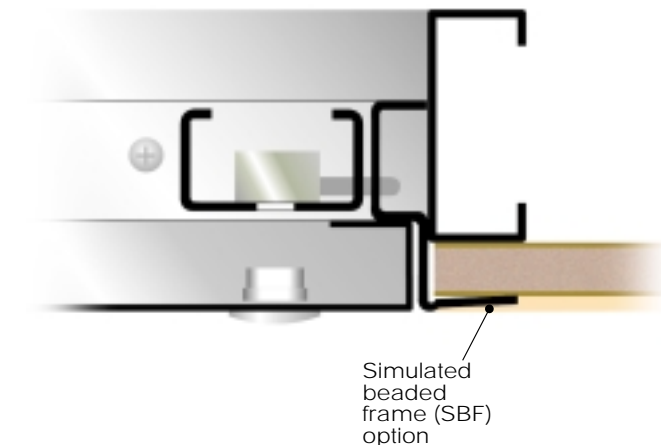
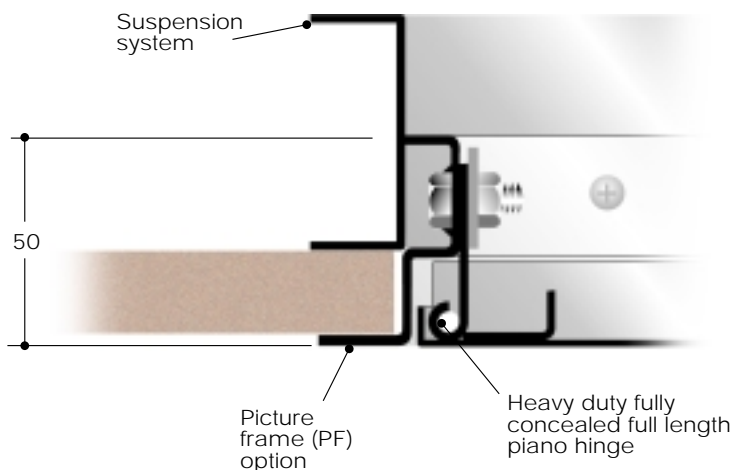



Firepan Magna

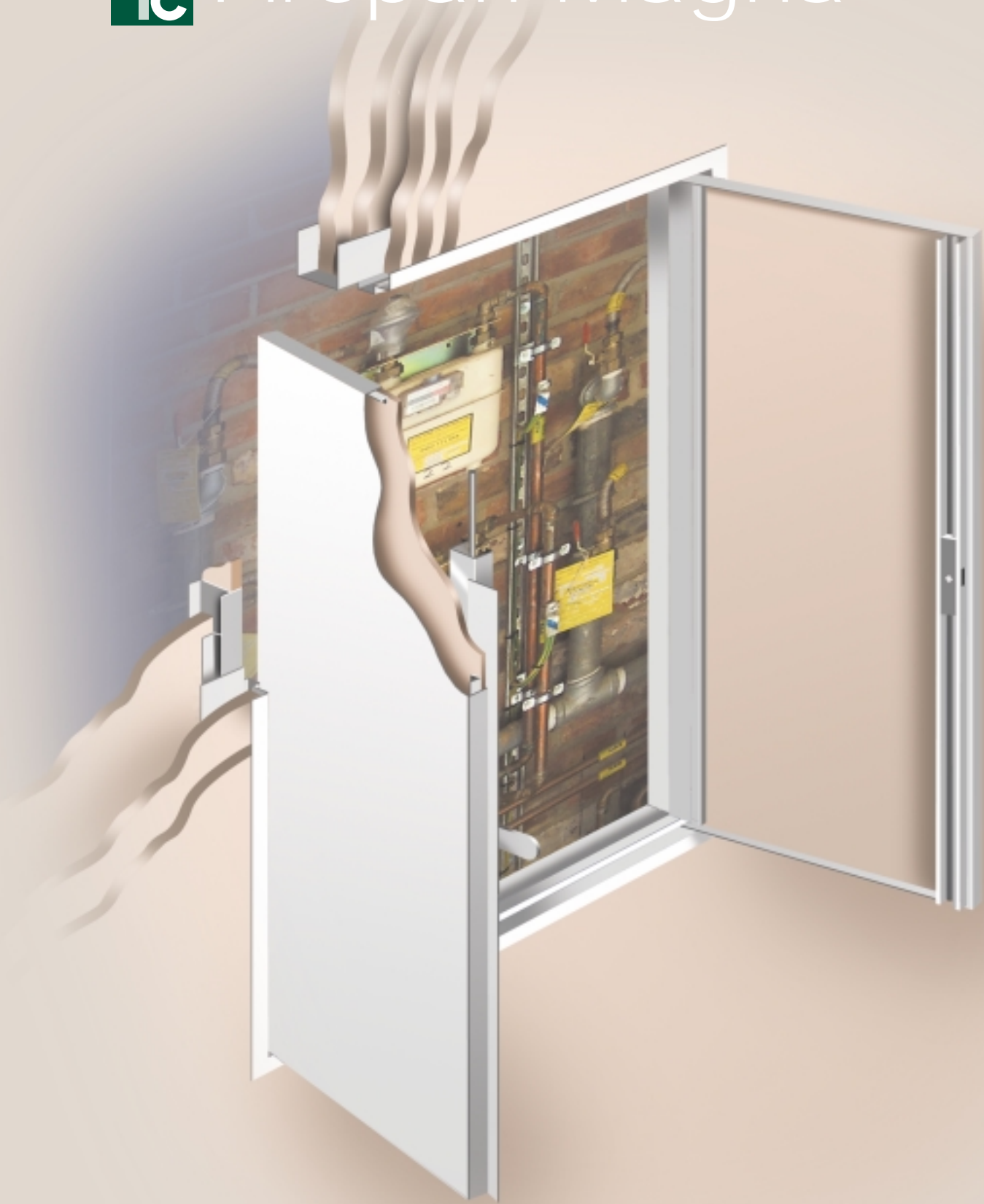

Firepan Magna PF60 Firepan Magna PF120 Firepan Magna SBF60 Firepan Magna SBF120

PANELCRAFT ACCESS PANELS have developed the FIREPAN MAGNA RANGE these are double door panels to complement the Firepan Range, providing an effective solution to gain access to building engineering services concealed in wall structures which serve fire protection or separation purposes.

Availability
Bespoke panels made to order

Sizes
Maximum Size 2000mm x 1200mm

NOTE Add 15mm to above sizes for structural opening

- ❖ Fire rated.
- ❖ Designed for walls only
- ❖ Provides 60min or 120min Fire Protection for walls
- ❖ Provides 60min or 120min Fire Integrity from both sides for walls only
- ❖ 50mm overall depth
- ❖ Precision manufactured in Zintec.
- ❖ Fully concealed full length heavy duty piano hinge
- ❖ Visible picture frame (PF) or simulated beaded frame (SBF) for taping and jointing to conceal the frame.
- ❖ Supplied powder coated RAL 9010 20% gloss as standard
- ❖ Budget lock as standard
- ❖ Key lock or security lock options available depending on specification
- ❖ No on site manufacturing costs
- ❖ Easily installed in minutes straight from the box
- ❖ Suitable for on-site decoration to match the surrounding areas if required
- ❖ Doors easily removed

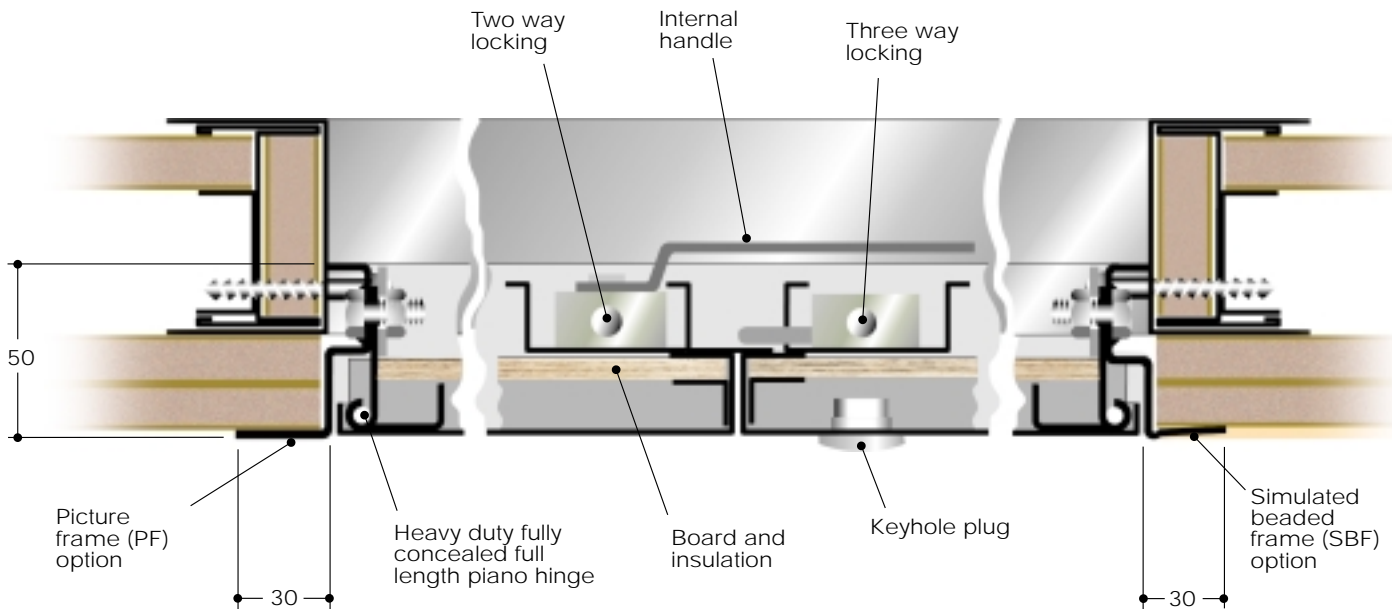

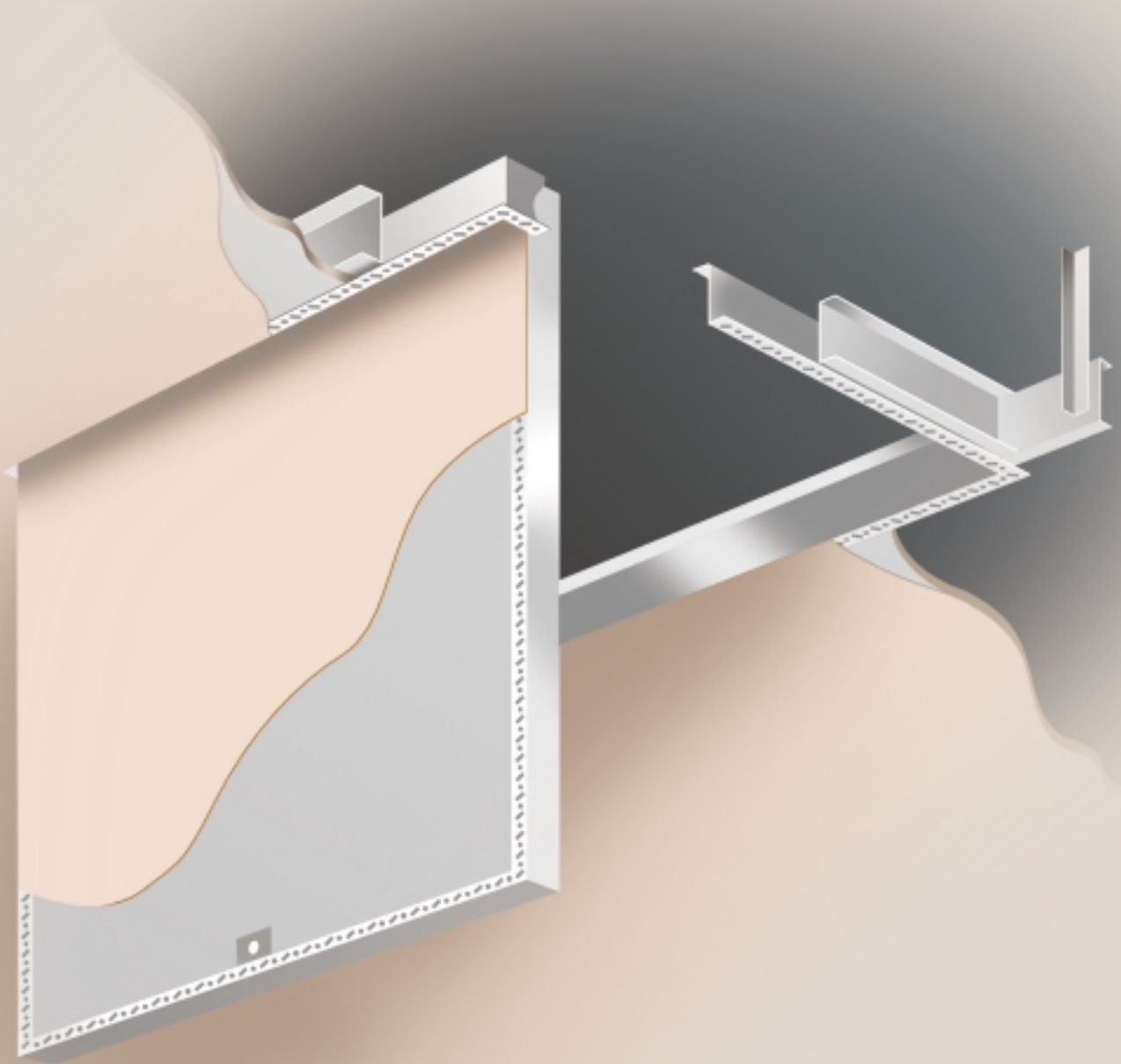

Plastapan SBF

PANELCRAFT ACCESS PANELS have developed the PLASTAPAN RANGE incorporating plasterboard-faced doors due to the preferences of some building specifiers. Designed as an effective solution to gain access to building engineering services concealed behind jointless plasterboard ceiling systems.

Availability

Standard sizes EX STOCK for Next Day Delivery

Standard Sizes

H	W
300	300
450	450
600	600

NOTE Add 15mm to above sizes for structural opening

- ❖ Fire Rated and Non-Fire Rated
- ❖ Designed for ceilings only
- ❖ 50mm overall depth
- ❖ Precision manufactured in Zintec.
- ❖ Door has integrated simulated bead for taping and jointing complete with factory fitted plasterboard
- ❖ Simulated beaded frame (SBF) for taping and jointing to conceal the frame.
- ❖ Supplied powder coated RAL 9010 20% gloss as standard
- ❖ Budget lock as standard
- ❖ Keylock or security lock options available depending on specification
- ❖ No on site manufacturing costs
- ❖ Easily installed in minutes straight from the box
- ❖ Suitable for on-site decoration to match the surrounding areas
- ❖ Door easily removed without use of tools

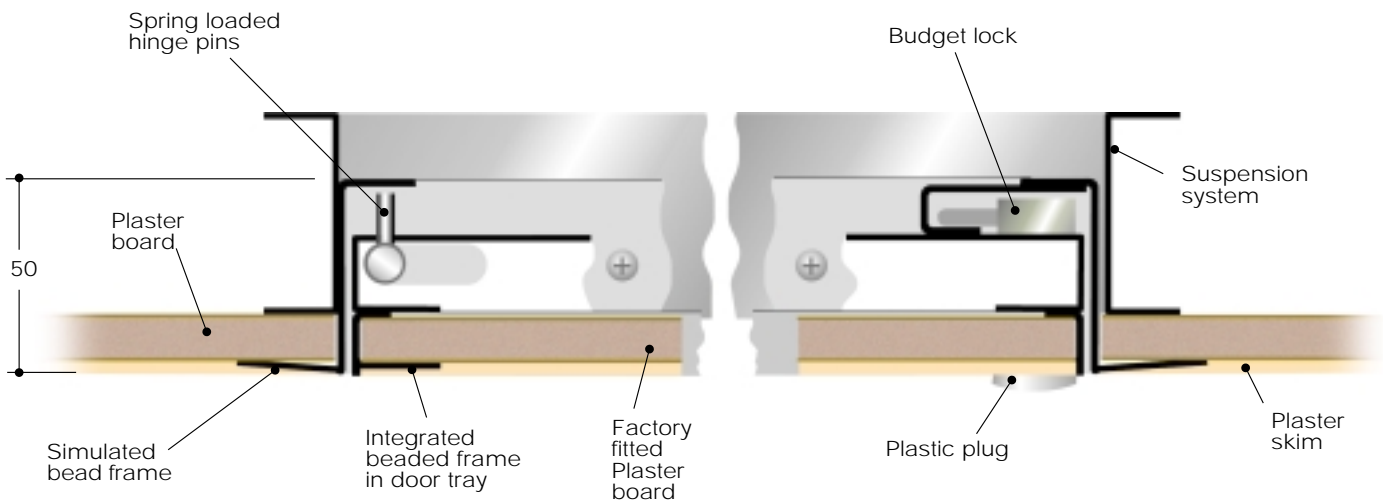



Panelcraft Access Panels Limited

UNIT H, THE PAVILIONS, ABELES WAY
HOLLY LANE INDUSTRIAL ESTATE
ATHERSTONE

WARWICKSHIRE CV9 2QZ
t: 01827 720830 f: 01827 720860
e: sales@panelcraftaccesspanels.com
www.panelcraftaccesspanels.com

BESPOKE ACCESS PANELS • BULKHEADS • LIGHT TROUGHES • ARCHITECTURAL SHEET METALWORK