

Product description

Inkoflex couplings IFK

The INKOMA-Inkoflex coupling is designed for the transmission of torque between two shafts where accuracy of alignment cannot be guaranteed, or where the alignment of the shafts can vary during operation.

The INKOMA-Inkoflex coupling compensates for both radial and angular misalignment of the shafts in operation, within the stated limiting values.

Features of the INKOMA-Inkoflex coupling:

- rigid connection of shafts with compensation of both radial and angular misalignments
- no loss of synchronicity
- dynamically balanced
- short installed length
- no radial loads on shaft support bearings
- compensates for considerable radial offset and up to 5° of angular offset
- maintenance free
- all-steel construction

The INKOMA-Inkoflex range comprises two coupling designs:

1. Type **IFK** which is a complete flexible coupling
2. Type **IFE (single disc coupling)** - an accessory for the PK coupling where misalignment exists.

Patents for the INKOMA-Inkoflex coupling have been applied for in all industrialised European countries

This brochure contains all necessary information for the selection, installation and operation of the standard range of INKOMA-Inkoflex couplings.

Special sizes and designs are possible. Please enquire.

INKOMA - GROUP
Couplings

by

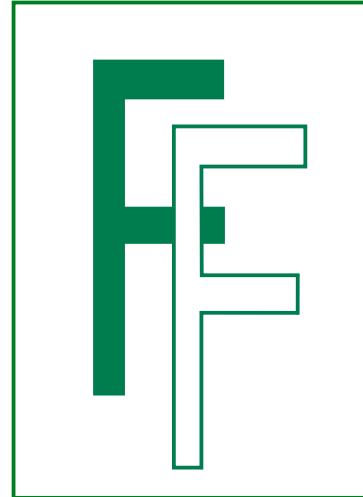

FRANCIS AND FRANCIS Ltd.
www.powertransmissions.co.uk

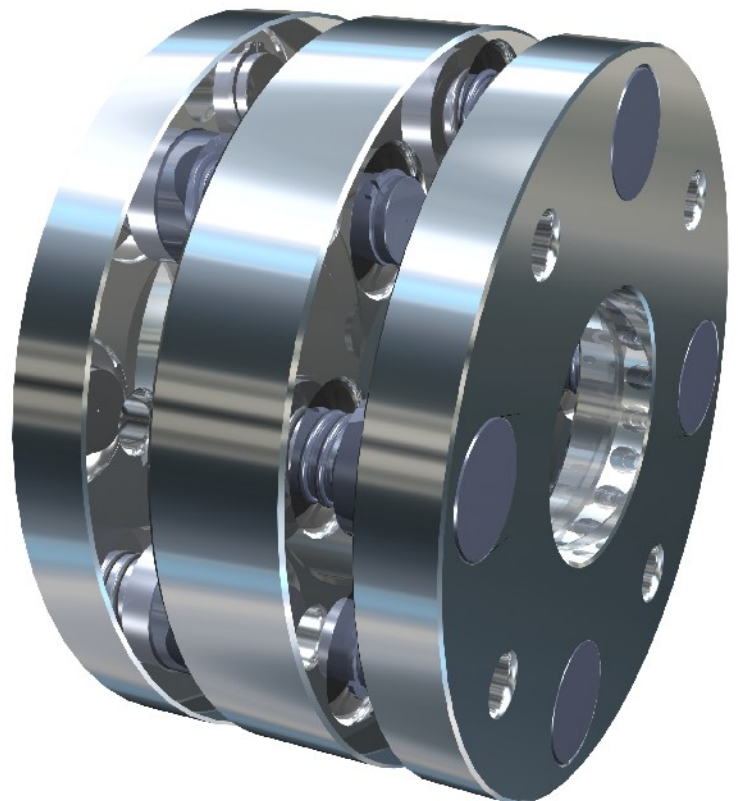

Contents list

Inkoflex couplings IFK

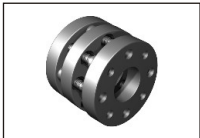
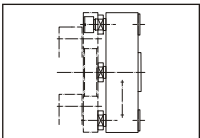
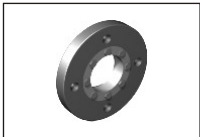
		Technical information versions A1, A2, A3, A4, A5, A6, A7	Page 003
		Calculations theoretical expected life permissible torque	Page 004 - 005
		Dimensions IFK 42 - IFK 340 Inkoflex coupling IFK (A1, A2, A3, A4, A5, A6, A7)	Page 006 - 009
		Dimensions for GFL - separable flange for versions A4 and A6	Page 010 - 011
		Dimensions for IFE 44 - IFE 460 Inkoflex single disc coupling	Page 012 - 013
		Dimensions for ISP-C - Inkofix tension flange for version A3	Page 014 - 015

Technical information

Inkoflex couplings IFK

INKOMA-Inkoflex coupling IFK is available in the following versions:

A1= Basic version:

Both outer discs have tapped holes for connecting components. The number of tapped holes on pitch circle "C":

- 3 flexing drive module= 3 × 120°
- 4 flexing drive module= 4 × 90°
- 5 flexing drive module= 5 × 72°
- 6 flexing drive module= 6 × 60°

A2= Hub version:

Both outer discs have finished bores in outward facing hubs.

A3= Tension hub version:

Basic version A1 with additional shrink disc. The shrink disc allows keyless fitting to the shaft.

For details of the tension flange see page 14.

A4= Separable hub version:

Basic version A1 with additional adaptor flanges. These flanges have hubs for shaft fitting.

For details of separable flanges see page 10.

A5= Hub version with inward facing integral hubs:

Both outer discs have finished bores in inward facing hubs. The axial length is the same as basic version A1 - A1.

A6= Separable hub version with inward facing integral hubs:

Basic version A1 with additional inward facing adaptor flanges.

For details of separable flanges see page 10.

A7= Split hub version:

This hub version has two components - a fixed and a removable part allowing radial clamping to the shaft. This version requires no axial displacement of the shaft for assembly and disassembly.

Combinations:

Each coupling can combine any of these versions. E.g. A1/A2 - one disc with tapped holes and the other with outward facing bored hub. All versions may be combined with one another, e.g. A3/A4, A1/A4, A2/A3, etc.

Special versions:

In addition to basic versions, customer specific executions are also possible e.g. incorporating sprocket, gears, shaft, etc. in the outer discs.

INKOMA-Inkoflex single disc coupling

The INKOMA-Inkoflex single disc coupling has the same number of drive modules as the related PK coupling has pairs of links. I.e. 3, 4, 5 or 6 drive modules. The drive module threaded pins are used to connect the INKOMA-Inkoflex single disc coupling with the PK coupling.

Applications for INKOMA-Inkoflex couplings:

INKOMA-Inkoflex couplings are widely used to compensate for misalignment.

They are widely used where two shafts have relatively small deviations from correct alignment (radial up to 1 mm and angular up to 5°) and torsional stiffness is essential.

Inaccuracies result from manufacturing and assembly tolerances. By using INKOMA-Inkoflex couplings wider tolerances can be accepted and the manufacturing cost reduced.

Deviations can also result during operation, if for example two rollers need minute adjustment in respect of each other.

The INKOMA-Inkoflex single disc coupling IFE was developed as an accessory to the PK coupling (see catalogue PK couplings) and is used wherever the connection is not precisely parallel. Without a suitable coupling, reactive loads would occur leading to edge loading and premature failure of the bearings in the PK coupling. When the INKOMA-Inkoflex single disc coupling is used with the PK coupling, parallel deviations up to 50 are compensated, leading to trouble-free operation of the PK coupling. There are specific IFE couplings matched to PK couplings. I.e. for each PK coupling there is a suitable INKOMA-Inkoflex single disc coupling.

Notes for installation and operation

Axial length "A" is the assembly dimension for the coupling. The tolerances for this dimension are dependent on the coupling size as shown:

for coupling type	IFK 42, 64....and IFK 78... ± 0,5 mm,
	IFK 104....and IFK 124... ± 1,0 mm,
	IFK 146.... ± 1,5 mm,
	and IFK 220....and IFK 340... ± 2,5 mm.

for coupling type	IFE 44, 74....and IFE 101... ± 0,5 mm,
	IFE 134....and IFE 155... ± 1,0 mm,
	IFE 196.... ± 1,5 mm,
	and IFE 280....and IFE 460... ± 2,5 mm.

In addition the assembly dimensions for the PK coupling must be observed. (see catalogue PK couplings)

The dimension "W" listed in the brochure and dimensions for keyways are preferred dimensions.

Couplings having other bore dimensions are available. Please enquire.

INKOMA-Inkoflex couplings transmit only torque and can carry no axial load component. I.e. Any axial load element must be compensated for in the design.

INKOMA-Inkoflex couplings are lubricated for life. Under normal operational and environmental conditions no further lubrication should be necessary. The IFE coupling is, however, provided with greasing points should re-lubrication be necessary due to unusual loading or exceptional environmental or operational conditions.

When installing INKOMA-Inkoflex coupling IFK version A3 (Tension hub version) the installation must be carried out according to the following procedure.

1. Position the components
2. Assemble the tension flange to the shaft
3. Fix the tension flange to the coupling end disc

Calculations

Inkoflex couplings IFK

The theoretical expected life L_h [h] and the permissible torque T_{per} [Nm] depend on the angular misalignment α [°], the speed n [1/min] and the load factor [-]. The relevant factor can be found in the adjacent diagram and table. The input torque T_{kN} [Nm] should always be less than the permissible torque T_{per} [Nm].

Nominal input torque:

$$T_{kN} [\text{Nm}] = \frac{P_A [\text{kW}]}{n_A [1/\text{min}]}$$

Theoretical expected life:

Couplings should be fitted with a protective sleeve. This sleeve serves to avoid the loss of lubricant and to prevent the ingress of dust and other contamination to the INKOMA-Inkoflex coupling.

Theoretical expected life:

$$L_h [\text{h}] = 30000h \cdot f_\alpha^2 [-] \cdot f_R^2 [-] \cdot f_n^2 [-]$$

Permissible torque:

$$T_{per} [\text{Nm}] = T_{kN} [\text{Nm}] \cdot K [-] \cdot f_\alpha [-] \cdot f_R [-] \cdot f_n [-]$$

Load factor	K
no shock	1,0
moderate shock	1,8
heavy shock	2,5
heavy reversing shock	3,0

Factor for the applied angular misalignment f_α [-]

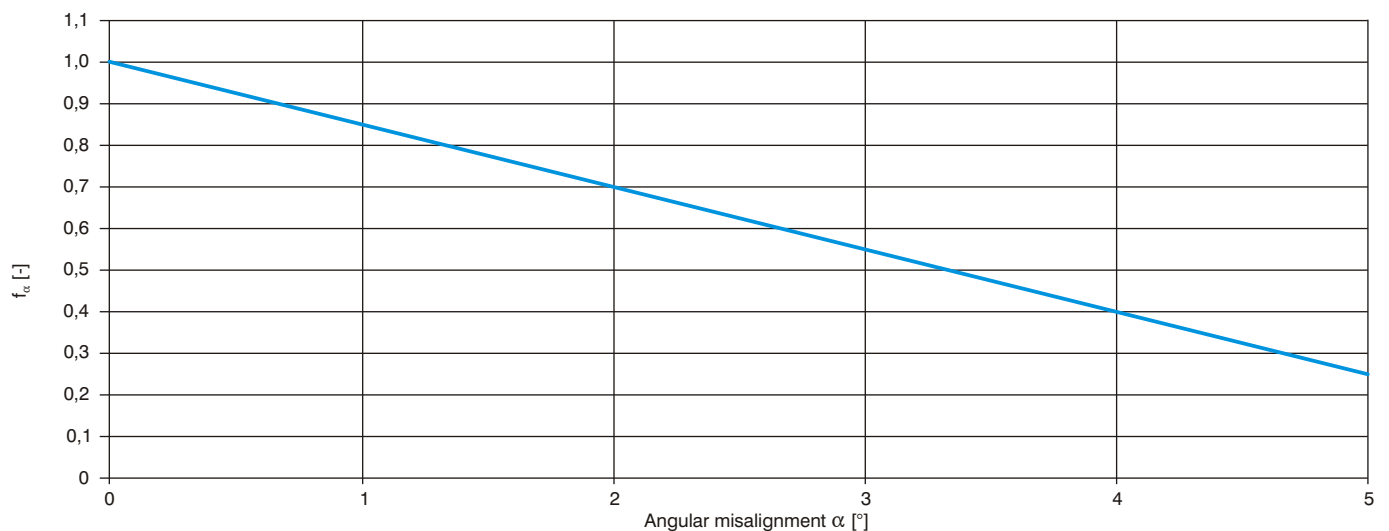

Factor for the applied radial offset f_R [-]

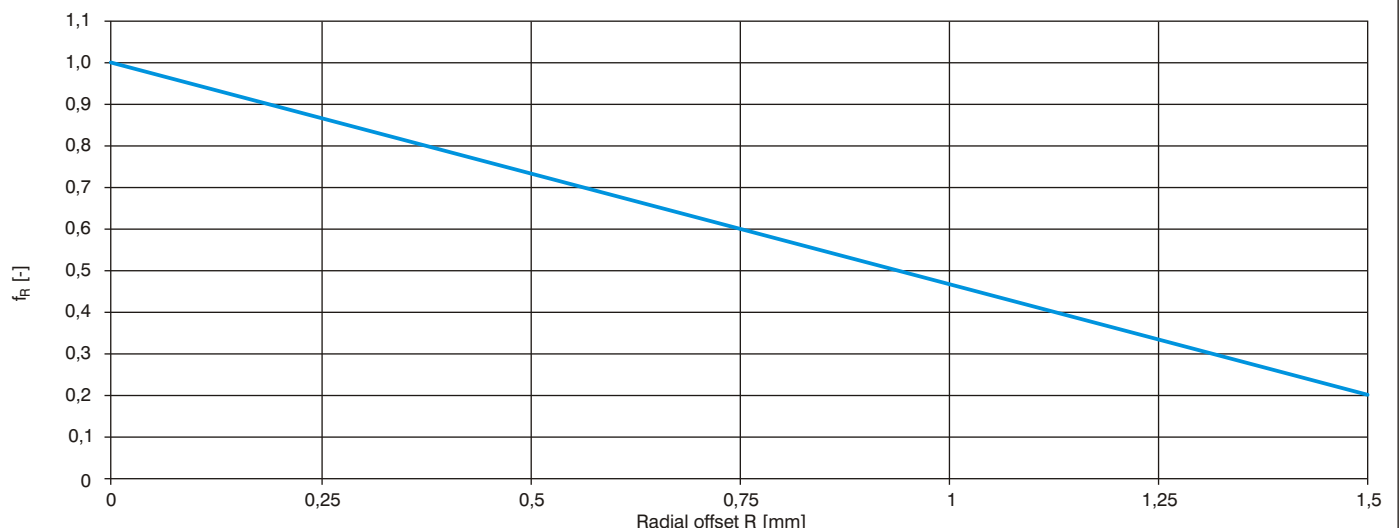

Calculations

Inkoflex couplings IFK

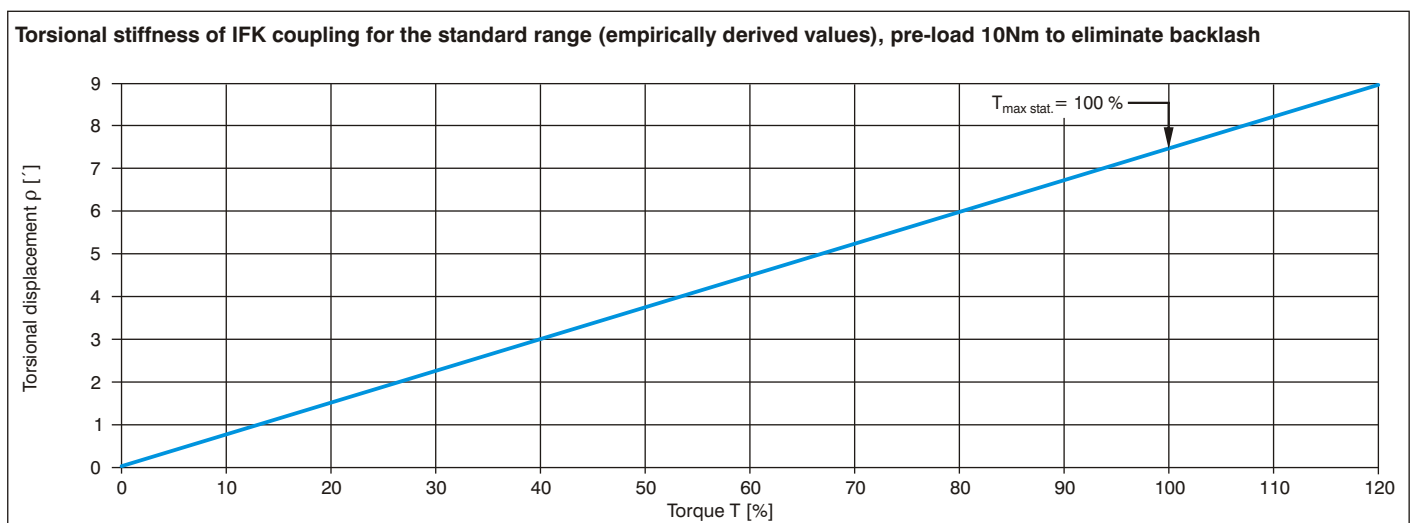
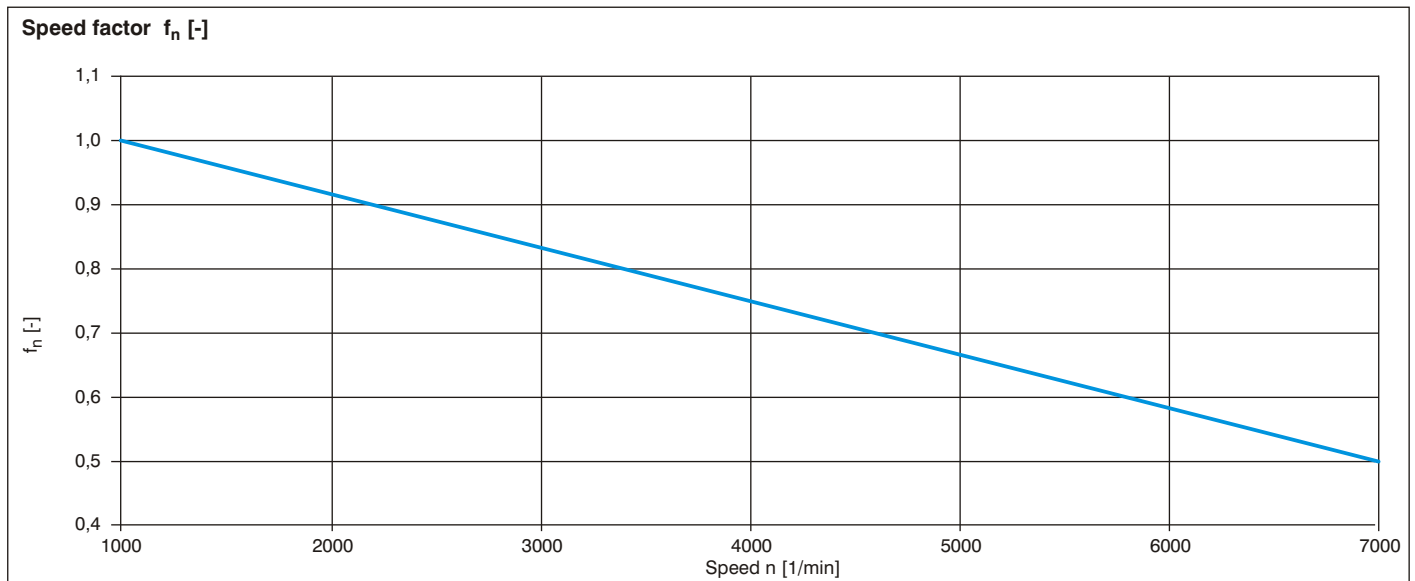

Example:

IFK 104.140/4

$T_{\text{stat.}} = 2600 \text{ Nm}$

$T_{\text{kN}} = 795,8 \text{ Nm}$

$T [\%] = 100\% \frac{T_{\text{kN}}}{T_{\text{stat.}}}$

$T [\%] = 100\% \frac{795,8 \text{ Nm}}{2600 \text{ Nm}} = 30,6\% \rightarrow \text{Torsional displacement } \rho = 2,2'$

Explanation:

- $T_{\text{stat.}}$ [Nm] = max. static torque
- T_{kN} [Nm] = nominal input torque
- T [%] = torque in %
- $T_{\text{per.}}$ [Nm] = permissible torque
- P_A [kW] = input power at the coupling
- n_A [1/min] = input speed
- L_n [h] = required life
- K [-] = load factor

Dimensions IFK 42 - IFK 340

Inkoflex coupling IFK (A1, A2, A3)

INKOMA-Inkoflex coupling IFK is normally available in the versions:

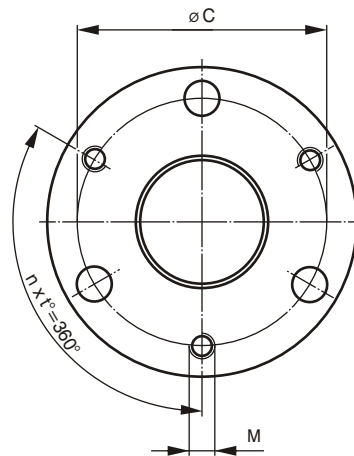
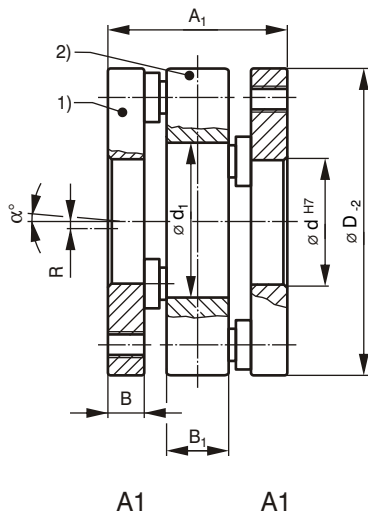

- 1) Outer disc
- 2) Centre disc
- 3) Outer disc with integral hub
- 4) Separable flange with hub
- 5) Outer disc with tension flange
- 6) Outer disc with split hub

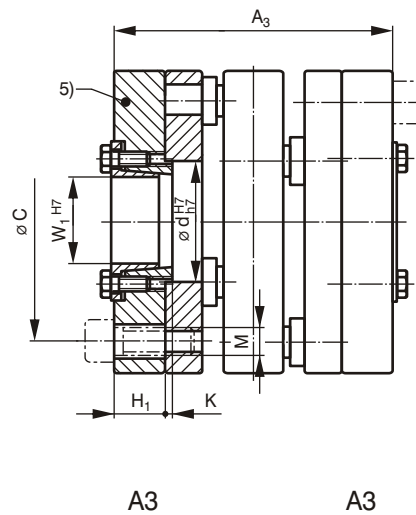
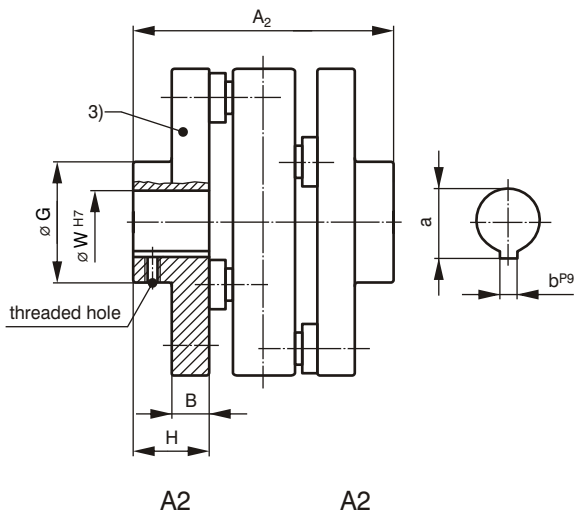

$$A3 = A1 + \text{ISP-C}$$

For further details see page 14 tension flange.

Ordering example:

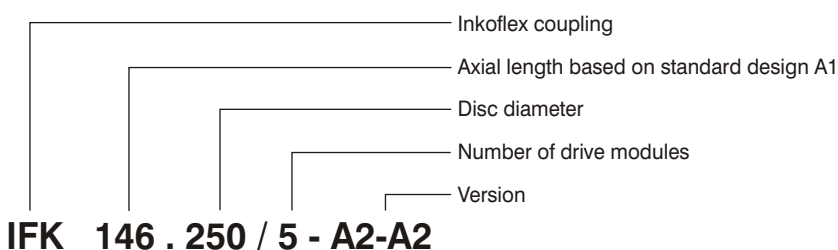

Dimensions IFK 42 - IFK 340

Inkoflex coupling IFK (A4, A5, A6, A7)

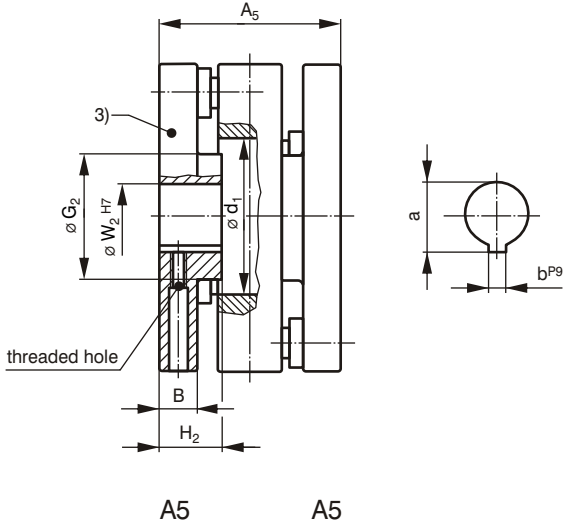
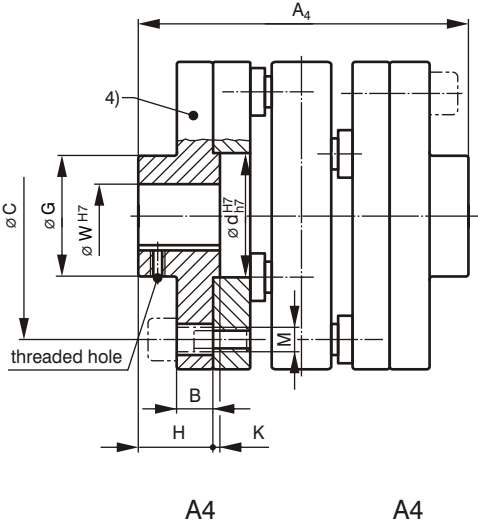

$A_4 = A_1 + GFL$

For missing dimensions and designations for GFL see page 10.

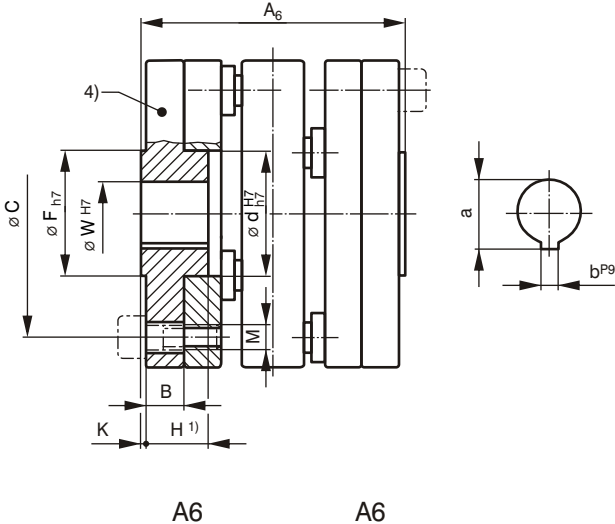

$A_6 = A_1 + GFL$

For missing dimensions and designations for GFL see page 10.

¹⁾ H_2 for IFK 64...

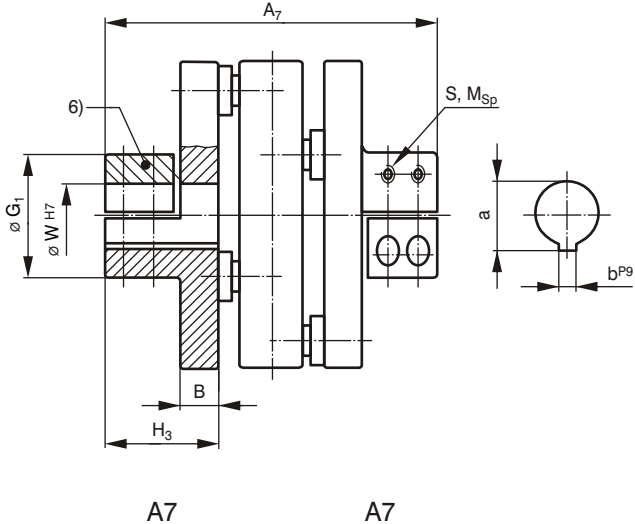

Dimensions IFK 42 - IFK 340

Inkoflex coupling IFK (A1, A2, A3, A4, A5, A6, A7)

Order code	Dimensions [mm]																									
	A ₁	A ₂	A ₃	A ₄	A ₅	A ₆	A ₇	B	B ₁	C	D	G	G ₁	G ₂	H	H ₁	H ₂	H ₃	K	W ₁	W ₁ ¹⁾	W ₂ ¹⁾	a	b	d	d ₁ max.
IFK 42.50/3	42	66	⁴⁾	82	42	62	74	8	15	35	52	28	46	16	20	12	20	24	2	14	⁴⁾	10 ²⁾	16,3	5	22	19
IFK 42.70/4	42	66	66	82	42	62	92	8	15	56	72	35	40	33	20	12	20	33	2	16	16	16	18,3	5	25	36
IFK 64.70/3	64	83	⁴⁾	104	64	89	114	10,5	20	48	72	35	37,5	20	20	14	20	35,5	2	16	16	12 ²⁾	18,3	5	25	24
IFK 64.90/4	64	117	92	138	64	91	124	10,5	20	70	93	55	50	40	37	14	30	40,5	3	25	25	25	28,3	8	45	45
IFK 64.120/4	64	127	96	148	64	91	134	10,5	20	98	122	60	60	55	42	16	30	45,5	3	30	30	30	33,3	8	50	70
IFK 78.120/4	78	131	128	162	78	115	158	16	22	90	120	65	65	60	42	25	37	56	3	30	30	30	33,3	8	50	65
IFK 78.140/4	78	151	138	182	78	115	168	16	22	110	140	70	70	65	52	30	37	61	3	35	35	35	38,3	10	55	70
IFK 78.160/4	78	151	138	182	78	115	178	16	22	130	160	70	80	70	52	30	37	66	3	40	40	40	43,3	12	60	75
IFK 104.140/4	104	163	174	208	104	155	204	22,5	30	100	140	70	75	55	52	35	49	72,5	3	35	35	35	38,3	10	55	60
IFK 104.160/4	104	163	174	208	104	155	214	22,5	30	120	160	85	80	75	52	35	49	77,5	3	40	40	40	43,3	12	60	80
IFK 124.160/4	124	178	204	228	124	180	234	25	40	115	160	75	90	65	52	40	52	80	3	40	40	40	43,3	12	60	70
IFK 124.180/4	124	198	214	248	124	180	244	25	40	135	180	90	100	70	62	45	58	85	3	45	45	45	48,8	14	70	80
IFK 124.200/4	124	218	224	268	124	180	244	25	40	152	200	100	100	80	72	50	58	85	3	50	50	50	53,8	14	80	90
IFK 146.200/4	146	226	266	286	146	216	³⁾	30	50	150	200	100	³⁾	80	70	60	68	³⁾	5	50	50	50	53,8	14	80	90
IFK 146.200/5	146	226	266	286	146	216	³⁾	30	50	150	200	100	³⁾	80	70	60	68	³⁾	5	50	50	50	53,8	14	80	90
IFK 146.250/4	146	246	286	306	146	216	³⁾	30	50	200	250	120	³⁾	115	80	70	68	³⁾	5	60	60	60	64,4	18	100	125
IFK 146.250/5	146	246	286	306	146	216	³⁾	30	50	200	250	120	³⁾	115	80	70	68	³⁾	5	60	60	60	64,4	18	100	125
IFK 146.250/6	146	246	286	306	146	216	³⁾	30	50	200	250	120	³⁾	115	80	70	68	³⁾	5	60	60	60	64,4	18	100	125
IFK 146.310/5	146	276	296	336	146	216	³⁾	30	50	260	310	160	³⁾	160	95	75	75	³⁾	5	80	80	80	85,4	22	150	180
IFK 146.310/6	146	276	296	336	146	216	³⁾	30	50	260	310	160	³⁾	160	95	75	75	³⁾	5	80	80	80	85,4	22	150	180
IFK 146.310/8	146	276	296	336	146	216	³⁾	30	50	260	310	160	³⁾	160	95	75	75	³⁾	5	80	80	80	85,4	22	150	180
IFK 220.350/4	220	354	³⁾	450	220	326	³⁾	48	³⁾	272	350	180	³⁾	³⁾	115	³⁾	³⁾	³⁾	5	80	80	80	85,4	22	180	³⁾
IFK 220.350/5	220	354	³⁾	450	220	326	³⁾	48	³⁾	272	350	180	³⁾	³⁾	115	³⁾	³⁾	³⁾	5	80	80	80	85,4	22	180	³⁾
IFK 220.400/5	220	394	³⁾	490	220	326	³⁾	48	³⁾	320	400	200	³⁾	³⁾	135	³⁾	³⁾	³⁾	5	80	80	80	85,4	22	200	³⁾
IFK 220.400/6	220	394	³⁾	490	220	326	³⁾	48	³⁾	320	400	200	³⁾	³⁾	135	³⁾	³⁾	³⁾	5	80	80	80	85,4	22	200	³⁾
IFK 340.480/4	340	³⁾	³⁾	³⁾	340	³⁾	³⁾	80	³⁾	350	480	³⁾	³⁾	³⁾	³⁾	³⁾	³⁾	³⁾	³⁾	³⁾	³⁾	³⁾	³⁾	³⁾	³⁾	³⁾
IFK 340.560/4	340	³⁾	³⁾	³⁾	340	³⁾	³⁾	80	³⁾	432	560	³⁾	³⁾	³⁾	³⁾	³⁾	³⁾	³⁾	³⁾	³⁾	³⁾	³⁾	³⁾	³⁾	³⁾	³⁾
IFK 340.560/5	340	³⁾	³⁾	³⁾	340	³⁾	³⁾	80	³⁾	432	560	³⁾	³⁾	³⁾	³⁾	³⁾	³⁾	³⁾	³⁾	³⁾	³⁾	³⁾	³⁾	³⁾	³⁾	³⁾
IFK 340.620/6	340	³⁾	³⁾	³⁾	340	³⁾	³⁾	80	³⁾	490	620	³⁾	³⁾	³⁾	³⁾	³⁾	³⁾	³⁾	³⁾	³⁾	³⁾	³⁾	³⁾	³⁾	³⁾	³⁾

¹⁾ preferred bore dimension, also available in other diameters

²⁾ keyway to BS 4235 (DIN 6885/1)

³⁾ hub length, diameter, bore to customer's specification

⁴⁾ version A3 cannot be supplied

For special sizes please enquire.

Operational data IFK 42 - IFK 340

Inkoflex coupling IFK (A1, A2, A3, A4, A5, A6, A7)

Order code	Mounting holes			Clamping screws A7		Operational data						Mass ⁶⁾	CAD-No:
	Thread M	Number n	Hole pitch t [°]	S	Tightening torque M _{Sp} [Nm]	Radial Offset R [±mm]	Angular misalignment α [°]	Power P n [kW /1/min]	Torque T _{stat.} [Nm]	Inertia ⁶⁾ J [kg cm ²]	max. speed ⁵⁾ n [1/min]		
IFK 42.50/3	M6	3	120	2xM5	6	0,5	5	0,008	66	3	3000	0,36	41001
IFK 42.70/4	M6	4	90	4xM5	6	0,5	5	0,014	206	5	3000	0,64	41011
IFK 64.70/3	M8	3	120	4xM5	6	0,5	5	0,026	252	13	3000	0,96	41201
IFK 64.90/4	M8	4	90	4xM6	10,5	1	5	0,051	490	35	3000	1,44	41211
IFK 64.120/4	M8	4	90	4xM8	25	1	5	0,071	686	118	2500	2,81	41221
IFK 78.120/4	M12	4	90	4xM8	25	1	5	0,109	1044	218	2500	4,28	41401
IFK 78.140/4	M12	4	90	4xM10	50	1	5	0,134	1275	324	2500	4,28	41411
IFK 78.160/4	M12	4	90	4xM10	50	1	5	0,158	1508	562	2500	7,83	41421
IFK 104.140/4	M16	4	90	4xM10	50	1	4	0,272	2600	402	2500	7,20	41601
IFK 104.160/4	M16	4	90	4xM12	87	1	4	0,330	3120	679	2500	9,45	41611
IFK 124.160/4	M16	4	90	4xM12	87	1	4	0,385	3680	778	2000	10,8	41801
IFK 124.180/4	M16	4	90	4xM12	87	1	3	0,452	4320	1194	1800	12,8	41811
IFK 124.200/4	M16	4	90	4xM12	87	1	3	0,509	4860	1927	1800	16,6	41821
IFK 146.200/4	M20	4	90	³⁾	³⁾	1	3	0,628	6000	3037	1800	20,8	42001
IFK 146.200/5	M20	5	72	³⁾	³⁾	1	3	0,785	7500	3037	1800	20,8	42011
IFK 146.250/4	M20	4	90	³⁾	³⁾	1	3	0,837	8000	6296	1800	32,8	42021
IFK 146.250/5	M20	5	72	³⁾	³⁾	1	3	1,047	10000	6296	1800	32,8	42031
IFK 146.250/6	M20	6	60	³⁾	³⁾	1	3	1,256	12000	6296	1800	33,8	42041
IFK 146.310/5	M20	5	72	³⁾	³⁾	1	3	1,361	13000	12585	1800	45,6	42051
IFK 146.310/6	M20	6	60	³⁾	³⁾	1	3	1,633	15600	12585	1800	45,8	42061
IFK 146.310/8	M20	8	45	³⁾	³⁾	1	3	2,170	20800	12585	1800	46,3	42071
IFK 220.350/4	M20	4	90	³⁾	³⁾	1	2	1,983	19040	39456	1700	96,4	42201
IFK 220.350/5	M20	5	72	³⁾	³⁾	1	2	2,492	23800	39456	1700	96,4	42211
IFK 220.400/5	M20	5	72	³⁾	³⁾	1	2	3,518	33600	74542	1700	149,0	42221
IFK 220.400/6	M20	6	60	³⁾	³⁾	1	2	4,617	44100	74542	1700	149,0	42231
IFK 340.480/4	³⁾	4	90	³⁾	³⁾	1	2	7,454	71225	211350	1000	316	42401
IFK 340.560/4	³⁾	4	90	³⁾	³⁾	1	2	9,158	87505	357240	1000	412	42411
IFK 340.560/5	³⁾	5	72	³⁾	³⁾	1	2	11,453	109384	357240	1000	412	42421
IFK 340.620/6	³⁾	6	60	³⁾	³⁾	1	2	15,547	148500	573088	1000	524	42431

³⁾ hub length, diameter, bore to customer's specification

⁵⁾ for speeds in excess of 1500 1/min and according to version
the couplings must be statically and dynamically balanced

⁶⁾ for version A1

Dimensions for GFL

GFL - separable flanges

For versions A4 and A6.

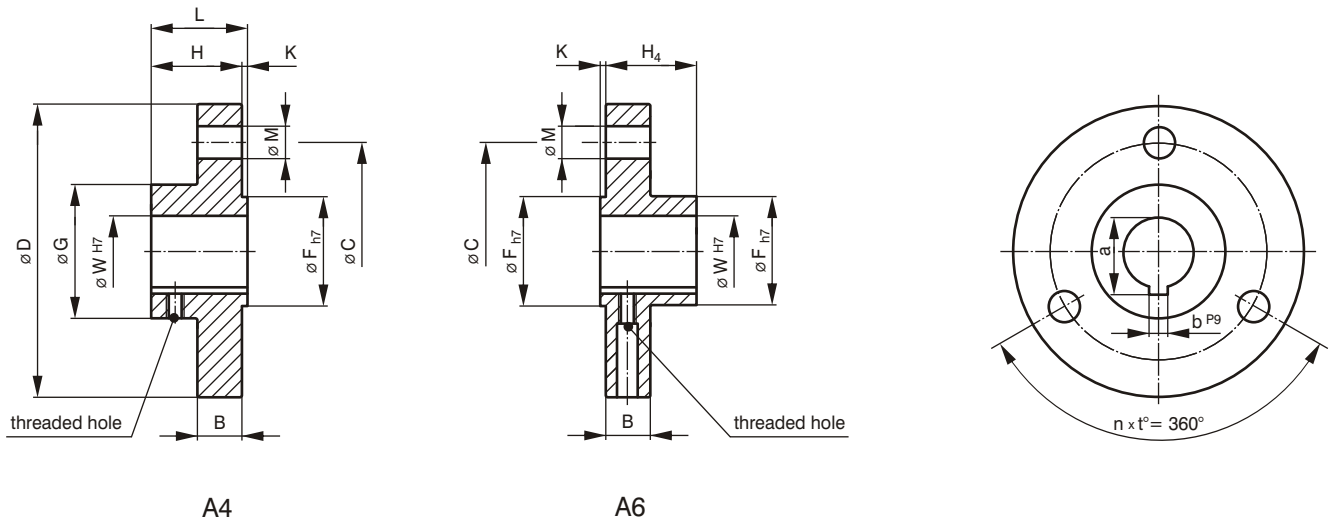

A4

A6

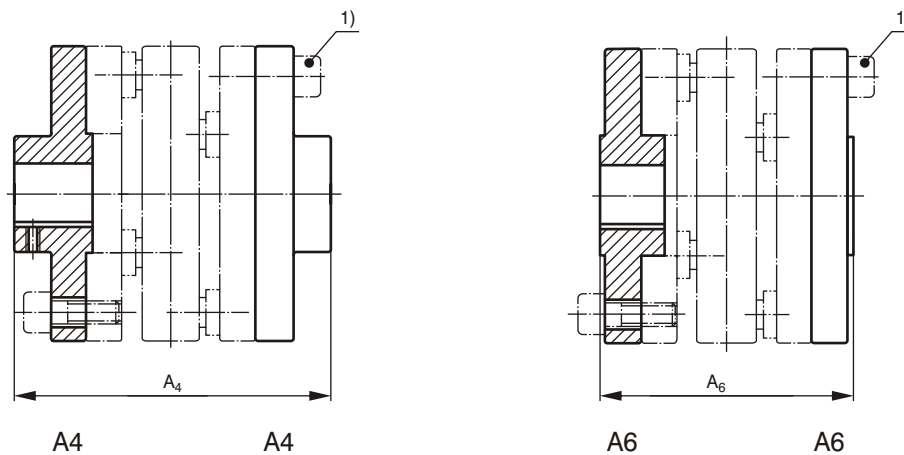

A4

A4

A6

A6

1) Mounting screws are not supplied.

Ordering example:

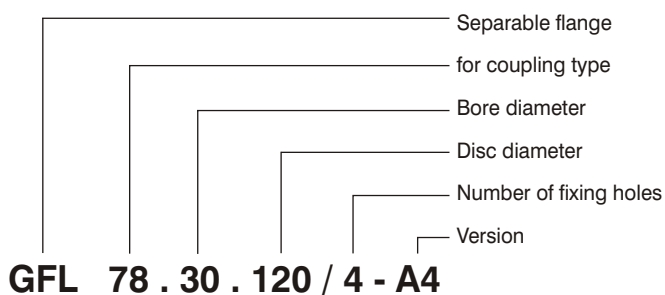

Order code	Dimensions [mm]													Mounting holes			Inertia J [kg cm ²]	Mass [kg]	CAD-No.:	
	B	C	D	F	G	H	H ₄	K	L	W ¹⁾	W _{max.}		a ²⁾	b ²⁾	Bore M [mm]	Number n				Hole pitch t [°]
											A4	A6								
GFL 42.14.50/3	8	35	50	22	24	20	20	2	22	14	14	14	16,3	5	6,6	3	120	5	0,16	43001
GFL 42.16.70/4	8	56	70	25	35	20	20	2	22	16	22	16	18,3	5	6,6	4	90	8	0,22	43002
GFL 64.16.70/3	10,5	48	70	25	35	20	20	2	22	16	22	16	18,3	5	9	3	120	10	0,38	43101
GFL 64.25.90/4	10,5	70	90	45	55	37	30	3	40	25	40	33	28,3	8	9	4	90	30	0,68	43102
GFL 64.30.120/4	10,5	98	120	50	60	42	30	3	45	30	45	38	33,3	8	9	4	90	80	1,1	43103
GFL 78.30.120/4	15,5	90	120	50	65	42	42	3	45	30	45	38	33,3	8	14	4	90	114	1,5	43301
GFL 78.35.140/4	15,5	110	140	55	70	52	52	3	55	35	50	40	38,3	10	14	4	90	208	2,0	43302
GFL 78.40.160/4	15,5	130	160	60	70	52	52	3	55	40	55	45	43,3	12	14	4	90	345	2,57	43303
GFL 104.35.140/4	22,5	100	140	55	70	52	52	3	55	35	50	40	38,3	10	18	4	90	290	2,78	43501
GFL 104.40.160/4	22,5	120	160	60	85	52	52	3	55	40	55	45	43,3	12	18	4	90	495	3,64	43502
GFL 124.40.160/4	25	115	160	60	75	52	52	3	55	40	55	45	43,3	12	18	4	90	495	3,97	43701
GFL 124.45.180/4	25	135	180	70	90	62	62	3	65	45	60	53	48,8	14	18	4	90	875	5,1	43702
GFL 124.50.200/4	25	125	200	80	100	72	72	3	75	50	70	65	53,8	14	18	4	90	1365	6,5	43703
GFL 146.50.200/4	30	150	200	80	100	70	70	5	75	50	70	65	53,8	14	22	4	90	1595	7,5	43801
GFL 146.50.200/5	30	150	200	80	100	70	70	5	75	50	70	65	53,8	14	22	5	72	1595	7,5	43802
GFL 146.60.250/4	30	200	250	100	120	80	80	5	85	60	80	80	64,4	18	22	4	90	3985	12,3	43803
GFL 146.60.250/5	30	200	250	100	120	80	80	5	85	60	80	80	64,4	18	22	5	72	3985	12,3	43804
GFL 146.60.250/6	30	200	250	100	120	80	80	5	85	60	80	80	64,4	18	22	6	60	3985	12,3	43805
GFL 146.80.310/5	30	260	310	150	160	95	95	5	100	80	100	100	85,4	22	22	5	72	13460	25,3	43806
GFL 146.80.310/6	30	260	310	150	160	95	95	5	100	80	100	100	85,4	22	22	6	60	13460	25,3	43807
GFL 146.80.310/8	30	260	310	150	160	95	95	5	100	80	100	100	85,4	22	22	8	45	13460	25,3	43808
GFL 220.80.350/4	48	272	325	180	180	115	115	5	120	80	120	120	85,4	22	22	4	90	24060	38,2	43901
GFL 220.80.350/5	48	272	325	180	180	115	115	5	120	80	120	120	85,4	22	22	5	72	24060	38,2	43902
GFL 220.80.400/5	48	320	375	200	200	135	135	5	140	80	140	140	85,4	22	22	5	72	42590	51,6	43903
GFL 220.80.400/6	48	320	375	200	200	135	135	5	140	80	140	140	85,4	22	22	6	60	42590	51,6	43904

1) Dimension "W" for the bore is a preferred value.

2) Value for dimension "W", in addition key to BS 4235 (DIN 6885/1)

Dimensions for IFE 44 - IFE 460

Inkoflex single disc coupling IFE

The INKOMA-Inkoflex single disc coupling has the same number of drive modules as the related PK coupling has pairs of links. I.e. 3, 4, 5 or 6 drive modules. The drive module threaded pins are used to connect the INKOMA-Inkoflex single disc coupling with the PK coupling.

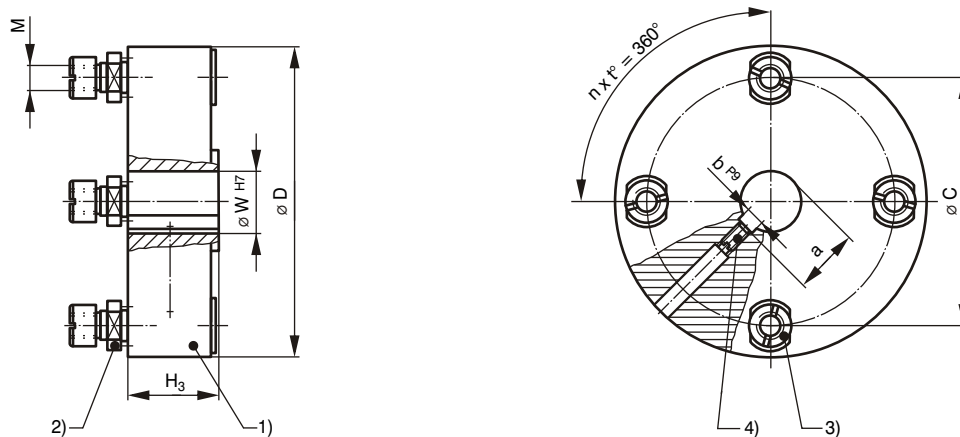

- 1) Coupling disc
- 2) Drive module
- 3) Locknut to DIN 546
- 4) Locking screw

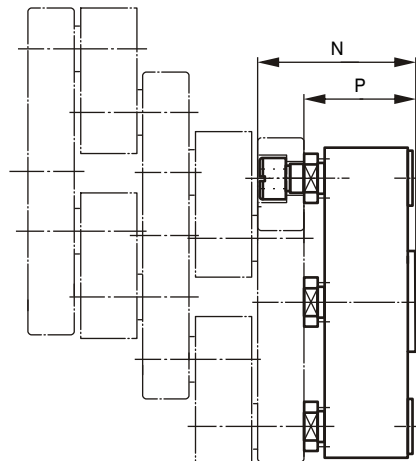

Ordering example:

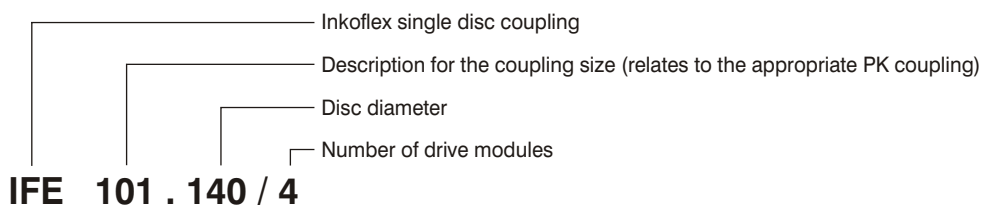

Order code	Dimensions [mm]									Mounting holes			Operational data					Mass [kg]	CAD-No.:
	P	N	H ₃	D	C	W	W _{max.}	a ²⁾	b ²⁾	Thread M	Number n	Hole pitch t [°]	Angular misalignment α [°]	Power P/n [kW / 1/min]	Torque T _{stat.} [Nm]	Inertia J [kg cm ²]	max. speed n [1/min]		
IFE 44.50/3	32	40	25	50	35	12	16	13,8	4	M6	3	120	2	0,008	66	2	3000	0,23	44001
IFE 44.70/6	32	40	25	70	56	14	30	16,3	5	M6	6	60	2	0,020	206	3	3000	0,40	44002
IFE 74.70/3	48	58,8	40	72	48	16	20	18,3	5	M8	3	120	2	0,026	252	8	3000	0,58	44101
IFE 74.90/3	48	58,8	40	93	70	25	35	28,3	8	M8	3	120	2	0,038	368	22	2500	0,90	44102
IFE 74.90/4	48	58,8	40	93	70	25	35	28,3	8	M8	4	90	2	0,051	490	22	2500	0,90	44103
IFE 74.120/3	48	58,8	40	120	98	30	50	33,3	8	M8	3	120	2	0,053	510	74	2500	1,75	44104
IFE 74.120/4	48	58,8	40	120	98	30	50	33,3	8	M8	4	90	2	0,071	686	74	2500	1,75	44105
IFE 74.150/4	48	58,8	40	150	128	30	80	33,3	8	M8	4	90	2	0,082	789	162	2500	2,60	44106
IFE 101.120/3	54	69,5	45	120	90	30	50	33,3	8	M12	3	120	2	0,081	783	117	2500	2,78	44301
IFE 101.120/4	54	69,5	45	120	90	30	50	33,3	8	M12	4	90	2	0,109	1044	117	2500	2,78	44302
IFE 101.140/3	54	69,5	45	140	110	30	60	33,3	8	M12	3	120	2	0,089	845	203	2000	3,68	44303
IFE 101.140/4	54	69,5	45	140	110	30	60	33,3	8	M12	4	90	2	0,134	1275	203	2000	3,68	44304
IFE 101.160/3	54	69,5	45	160	130	35	80	38,3	10	M12	3	120	2	0,118	1131	366	2000	5,10	44305
IFE 101.160/4	54	69,5	45	160	130	35	80	38,3	10	M12	4	90	2	0,158	1508	366	2000	5,10	44306
IFE 134.140/3	65	87,5	55	140	100	30	40	33,3	8	M16	3	120	2	0,204	1990	261	2000	4,68	44501
IFE 134.160/3	65	87,5	55	160	120	35	45	38,3	10	M16	3	120	2	0,245	2340	442	1800	6,15	44502
IFE 134.160/4	65	87,5	55	160	120	35	45	38,3	10	M16	4	90	2	0,330	3120	442	1800	6,15	44503
IFE 155.160/3	75	100	60	160	115	40	50	43,3	12	M16	3	120	2	0,289	2760	511	1800	7,10	44601
IFE 155.180/3	75	100	60	180	135	45	55	48,8	14	M16	3	120	1,5	0,339	3240	832	1800	8,92	44602
IFE 155.180/4	75	100	60	180	135	45	55	48,8	14	M16	4	90	1,5	0,452	4320	832	1800	8,92	44603
IFE 155.200/3	75	100	60	200	152	50	60	53,8	14	M16	3	120	1,5	0,377	3600	1242	1800	10,70	44604
IFE 155.200/4	75	100	60	200	152	50	60	53,8	14	M16	4	90	1,5	0,509	4860	1242	1800	10,70	44605
IFE 196.200/3	90	120	75	200	150	50	80	53,8	14	M20	3	120	1,5	0,471	4500	1971	1800	13,50	44701
IFE 196.200/4	90	120	75	200	150	50	80	53,8	14	M20	4	90	1,5	0,628	6000	1971	1800	13,50	44702
IFE 196.250/4	90	120	75	250	200	60	130	64,4	18	M20	4	90	1,5	0,837	8000	4089	1800	21,30	44703
IFE 196.250/5	90	120	75	250	200	60	130	64,4	18	M20	5	72	1,5	1,047	10000	4089	1800	21,30	44704
IFE 196.250/6	90	120	75	250	200	60	130	64,4	18	M20	6	60	1,5	1,256	12000	4089	1800	21,30	44705
IFE 196.310/6	90	120	75	310	260	70	160	74,9	20	M20	6	60	1,5	1,633	15600	8197	1800	29,70	44706
IFE 280.350/4	132	180	105	350	272	1)	1)	1)	1)	M20	4	90	1	1,983	19040	20803	1700	58,60	44801
IFE 280.350/5	132	180	105	350	272	1)	1)	1)	1)	M20	5	72	1	2,492	23800	20803	1700	58,60	44802
IFE 280.400/5	132	180	105	400	320	1)	1)	1)	1)	M20	5	72	1	3,846	36750	33634	1700	66,00	44803
IFE 280.400/6	132	180	105	400	320	1)	1)	1)	1)	M20	6	60	1	4,671	44100	33634	1700	66,00	44804
IFE 280.500/6	132	180	105	500	420	1)	1)	1)	1)	M20	6	60	1	5,167	51000	67545	1500	108,0	44805
IFE 460.425/3	194	274	155	425	300	1)	1)	1)	1)	1)	3	120	1	4,720	45100	65294	1300	118,5	44901
IFE 460.480/3	194	274	155	480	350	1)	1)	1)	1)	1)	3	120	1	5,583	53350	105321	1000	155,8	44902
IFE 460.480/4	194	274	155	480	350	1)	1)	1)	1)	1)	4	90	1	7,454	71225	105321	1000	155,8	44903
IFE 460.560/4	194	274	155	560	432	1)	1)	1)	1)	1)	4	90	1	9,158	87505	189211	1000	215,7	44904
IFE 460.560/5	194	274	155	560	432	1)	1)	1)	1)	1)	5	72	1	11,453	109384	189211	1000	215,7	44905
IFE 460.620/6	194	274	155	620	490	1)	1)	1)	1)	1)	6	60	1	15,547	148500	314158	1000	279,5	44906

¹⁾ Hub version and bore to customer requirements

²⁾ Value for dimension "W", in addition key to BS 4235 (DIN 6885/1)

For special sizes please enquire.

Dimensions for ISP-C

ISP-C - Inkofix Tension flange

For version A3.

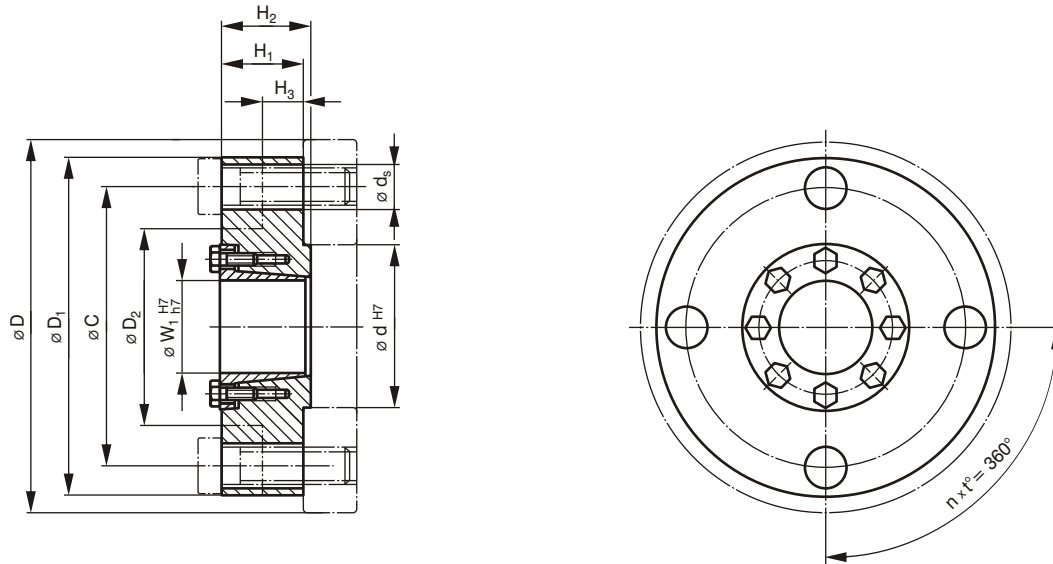

Explanation:

- $T_{stat.}$ = maximum transmissible torque for tension flange
- F_{ax} = maximum transmissible axial force for tension flange
- T_A = required tightening torque for the tension screws

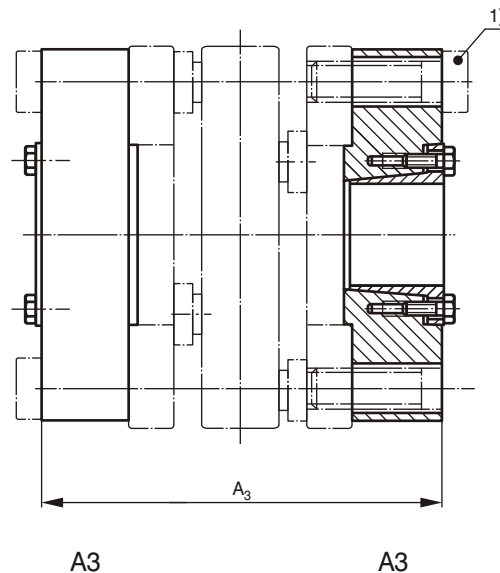

1) Mounting screws are not supplied.

Ordering example:

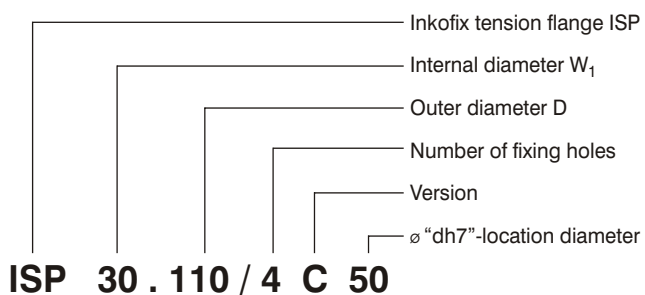

Order code Coupling	Order code Tension flange	Dimensions [mm]									Mounting holes			Tension screw		Operational data				Mass [kg]	CAD-No.:
		d	C	D	D ₁	D ₂	H ₁	H ₂	H ₃	W ₁ ¹⁾	d _s	n	t [°]	ISO 4017 (DIN 933) 10.9	Tightening torque T _A [Nm]	Torque T _{stat.} [Nm]	F _{ax} max. axial force [kN]	J Inertia [kg cm ²]			
IFK 42.70/4	ISP 16.66/4C25	25	56	72	66	-	12	14	-	16	6,6	4	90	6xM5x10	7	90	13	1,7	0,30	53601	
IFK 64.90/4	ISP 25.82/4C45	45	70	93	82	-	14	17	-	25	9	4	90	8xM5x16	7	340	27	4,9	0,53	53604	
IFK 64.120/4	ISP 30.115/4C50	50	98	122	115	-	16	19	-	30	9	4	90	8xM5x16	7	680	45	21,5	1,22	53609	
IFK 78.120/4	ISP 30.110/4C50	50	90	120	110	-	25	28	-	30	14	4	90	8xM5x16	7	982	65	28	1,73	53607	
IFK 78.140/4	ISP 35.130/4C55	55	110	140	130	-	30	33	-	35	14	4	90	8xM6x16	12	1195	68	66	2,90	53631	
IFK 78.160/4	ISP 40.150/4C60	60	130	160	150	-	30	33	-	40	14	4	90	8xM6x16	12	1920	96	117	3,90	53618	
IFK 104.140/4	ISP 35.125/4C55	55	100	140	125	-	35	38	-	35	18	4	90	8xM6x16	12	1385	79	57	2,60	53632	
IFK 104.160/4	ISP 40.145/4C60	60	120	160	145	-	35	38	-	40	18	4	90	8xM6x16	12	2220	111	119	4,19	53616	
IFK 124.160/4	ISP 40.140/4C60	60	115	160	140	-	40	43	-	40	18	4	90	8xM6x16	12	2460	123	118	4,44	53630	
IFK 124.180/4	ISP 45.160/4C70	70	135	180	160	-	45	48	-	45	18	4	90	10xM6x16	12	3000	133	226	6,54	53620	
IFK 124.200/4	ISP 50.180/4C80	80	152	200	180	120	50	53	20	50	18	4	90	10xM6x20	12	4100	164	402	9,21	53622	
IFK 146.200/4	ISP 50.185/4C80	80	150	200	185	116	60	65	28	50	22	4	90	10xM6x20	12	5200	208	538	11,73	53624	
IFK 146.200/5	ISP 50.185/5C80	80	150	200	185	116	60	65	28	50	22	5	72	10xM6x20	12	5200	208	538	11,73	53633	
IFK 146.250/4	ISP 60.230/4C100	100	200	250	230	-	70	75	-	60	22	4	90	10xM6x20	12	9800	327	1500	21,27	53625	
IFK 146.250/5	ISP 60.230/5C100	100	200	250	230	-	70	75	-	60	22	5	72	10xM6x20	12	9800	327	1500	21,27	53626	
IFK 146.250/6	ISP 60.230/6C100	100	200	250	230	-	70	75	-	60	22	6	60	10xM6x20	12	9800	327	1500	21,27	53627	
IFK 146.310/5	ISP 80.290/5C150	150	260	310	290	-	75	80	-	80	22	5	72	10xM8x25	32	13600	340	4061	35,90	53634	
IFK 146.310/6	ISP 80.290/6C150	150	260	310	290	-	75	80	-	80	22	6	60	10xM8x25	32	13600	340	4061	35,90	53628	
IFK 146.310/8	ISP 80.290/8C150	150	260	310	290	-	75	80	-	80	22	8	45	10xM8x25	32	13600	340	4061	35,90	53635	

1) Dimension "W" is a preferred dimension for the bore.