



MEGADYNE

0011



POLYURETHANE MULTIGRIP BELTS

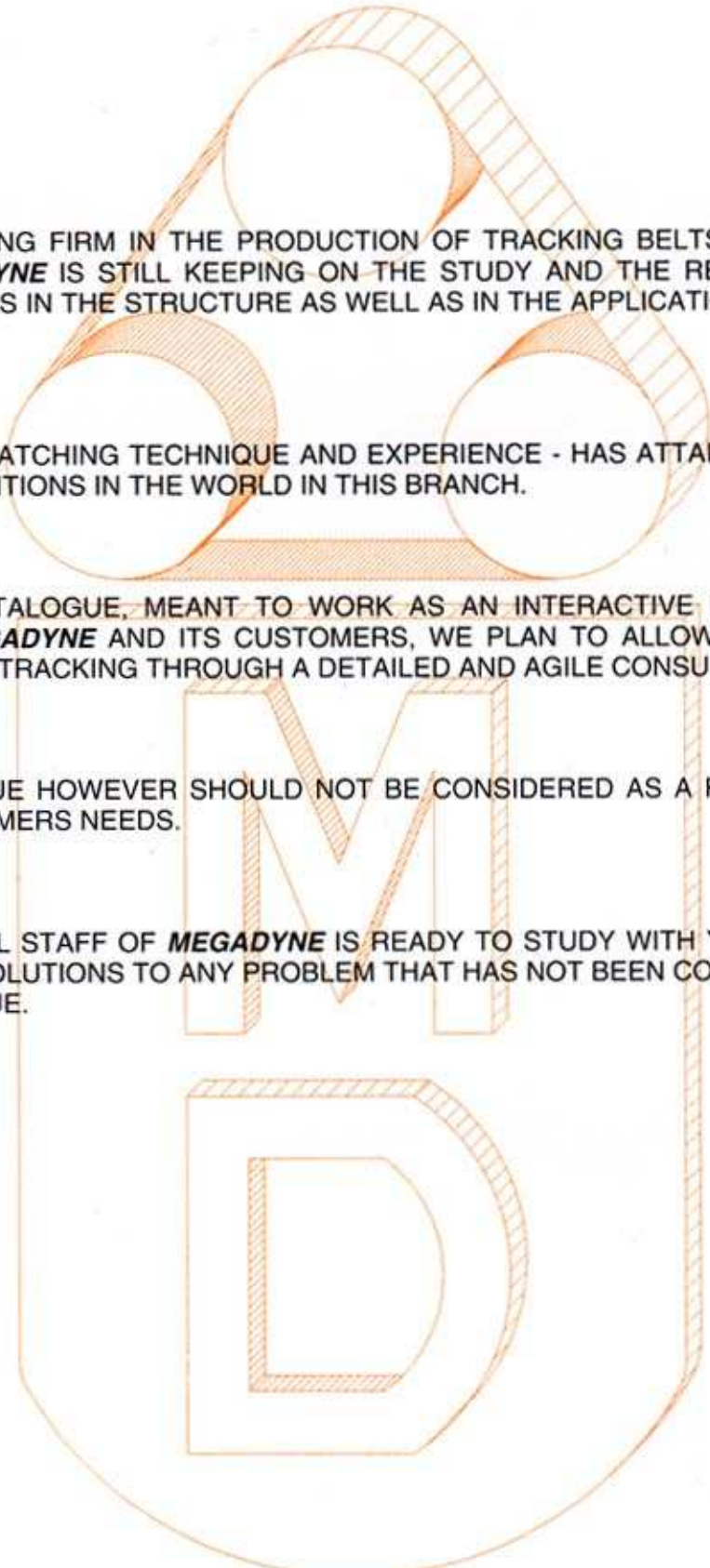

BEING A LEADING FIRM IN THE PRODUCTION OF TRACKING BELTS SINCE THE 1950's, **MEGADYNE** IS STILL KEEPING ON THE STUDY AND THE RESEARCH OF NEW SOLUTIONS IN THE STRUCTURE AS WELL AS IN THE APPLICATIONS OF NEW MATERIALS.

MEGADYNE - MATCHING TECHNIQUE AND EXPERIENCE - HAS ATTAINED ONE OF THE FIRST POSITIONS IN THE WORLD IN THIS BRANCH.

WITH THIS CATALOGUE, MEANT TO WORK AS AN INTERACTIVE INSTRUMENT BETWEEN **MEGADYNE** AND ITS CUSTOMERS, WE PLAN TO ALLOW A CAREFUL STUDY OF THE TRACKING THROUGH A DETAILED AND AGILE CONSULTATION.

THE CATALOGUE HOWEVER SHOULD NOT BE CONSIDERED AS A RESTRICTION OF THE CUSTOMERS NEEDS.

THE TECHNICAL STAFF OF **MEGADYNE** IS READY TO STUDY WITH YOU ALL THE NECESSARY SOLUTIONS TO ANY PROBLEM THAT HAS NOT BEEN CONSIDERED IN THE CATALOGUE.

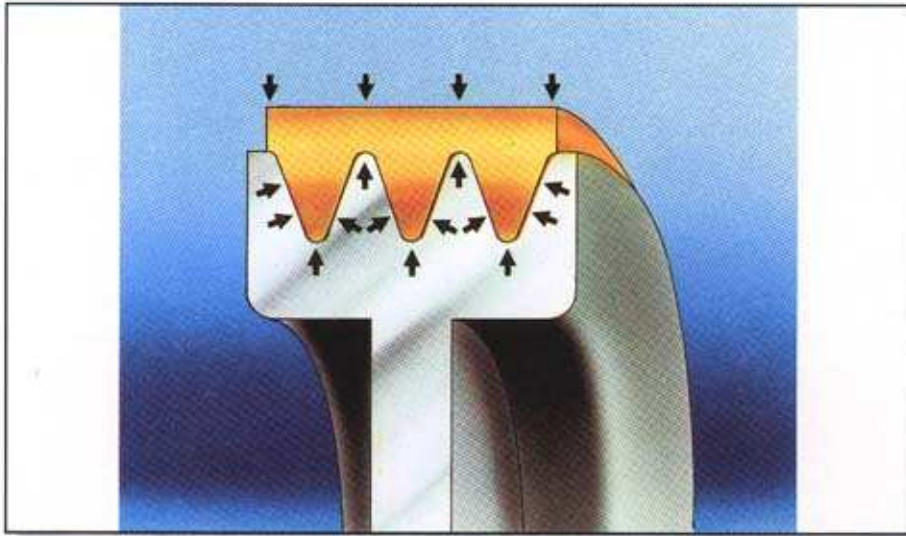

Megadyne Polyurethane Belts are the result of the high experience in the production of **Flat Belts** with the **high technology** in the **Polyurethan** treatment.

Multigrip combine the **high flexibility** of flat belts with the **power transmission** of a **V-Belts**.

The **longitudinal relieves** are studied in order to permit the **best connection** into the **grooves** of the pulleys.

Compared with the traditional types of belts they present the **following advantages**:

- **Dimensional Stability**
- **Maximum Stillness**
- **Optimum Flexibility**
- **Little Diameter of Pulleys**
- **Very High Speed**
- **Excellent Resistance at oils and ozone**

The **Structure** of the belt consist in two different components:

- **Polyurethan with Hardness 85 ± 4 (shore A)**
- **Poliester high tenacity Cord**

The belts can work from -15° to $+80^{\circ}$.

Very good Resistance to oils and gasoline, to ozone and water.

Sector of application:

- **Food Processors**
- **Grass Cutters**
- **Electrical Household Appliances**
- **Washing Machines**
- **Elettrical Tools**
- **Wood Working Machines**

MULTIGRIP SE

A new Multigrip Belts have been developed by Megadyne with semi-elastic traction cord that can permit to be used on fixed inter-axes reducing possible vibrations and noise.

For Special Executions please contact **MEGADYNE TECHNICAL STAFF**.

BELT DATA

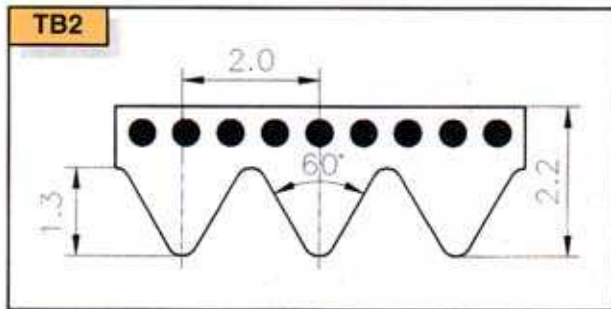

Standard Lengths [mm]
156
170
200
220
231
248
266
295
310
327
330
345
360
380
400
430
480
510
526
535
598
630
660
675
725
770
1186

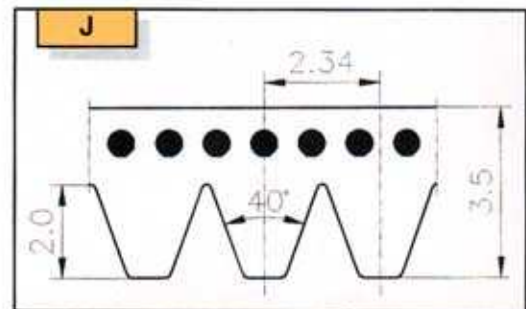

Standard Lengths [mm]	Standard Lengths [mm]
271	610
275	660
278	681
283	711
288	762
304	864
330	914
345	953
356	1010
381	1086
392	1120
406	1163
431	1202
444	1239
457	1245
483	1268
508	1397
558	

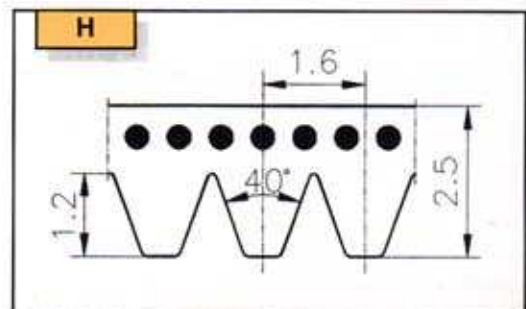

Standard Lengths [mm]	Standard Lengths [mm]
178	650
223	768
227	935
229	1000
295	1086
340	1120
375	1163
507	1203
588	1240
602	1775
609	

BELT CODE		
Width n° of ribs	Type	Length [mm]
6	TB2	330
8	J	406
10	H	1120

PULLEY DATA AND BELT TOLERANCES

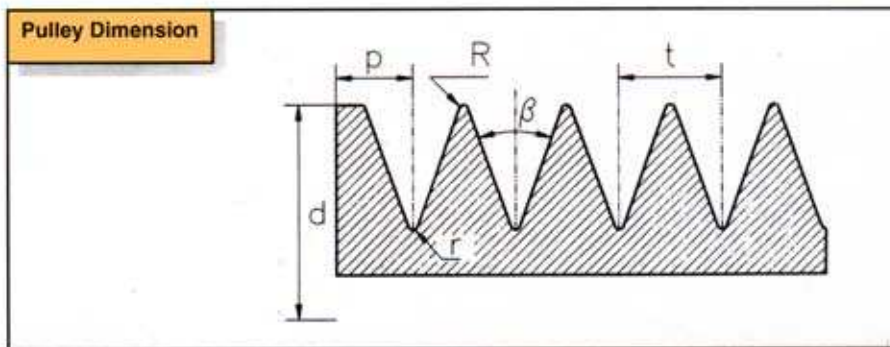

Type	TB2	J	H
Minimum Top radius R [mm]	0,30	0,20	0,15
Maximum Bottom radius r [mm]	0,15	0,40	0,30
Groove pitch t [mm]	2,00	2,34	1,6
Groove angle β [degrees]	60°	40°	40°
Permissible tolerance for t [mm]	$\pm 0,03$	$\pm 0,03$	$\pm 0,03$
Sum of permissible tolerances for t [mm]	$\pm 0,30$	$\pm 0,30$	$\pm 0,30$
p [mm]	1,3	1,8	1,3
Minimum diameter d [mm]	15	20	13

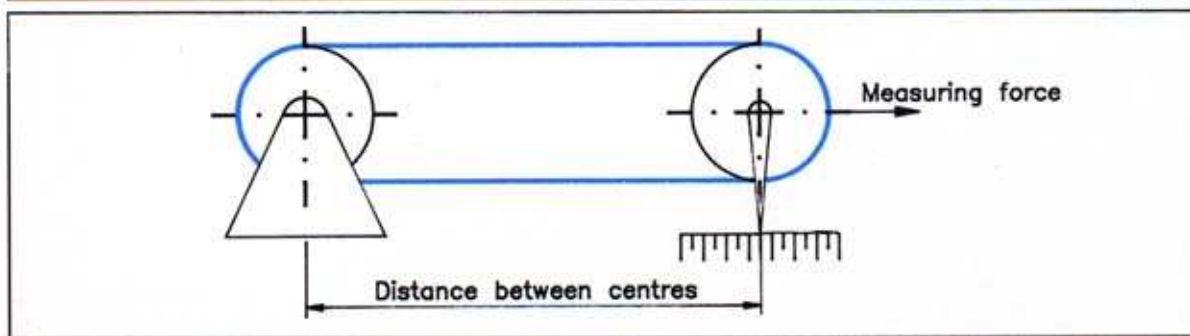

The effective length is verified placing the belt on two equal pulleys (diameter = 30 mm) having same groove profile.
The specified measuring tension F is applied to the shaft of one pulley.

Type	TB2		J		H
Tension F per rib	30 N		40 N		25 N
Belt Length Tolerances	<1000 +3 -5	>1000 +5 -10	<1000 +3 -5	>1000 +5 -10	+5 -10



Multigrip belt drives calculation

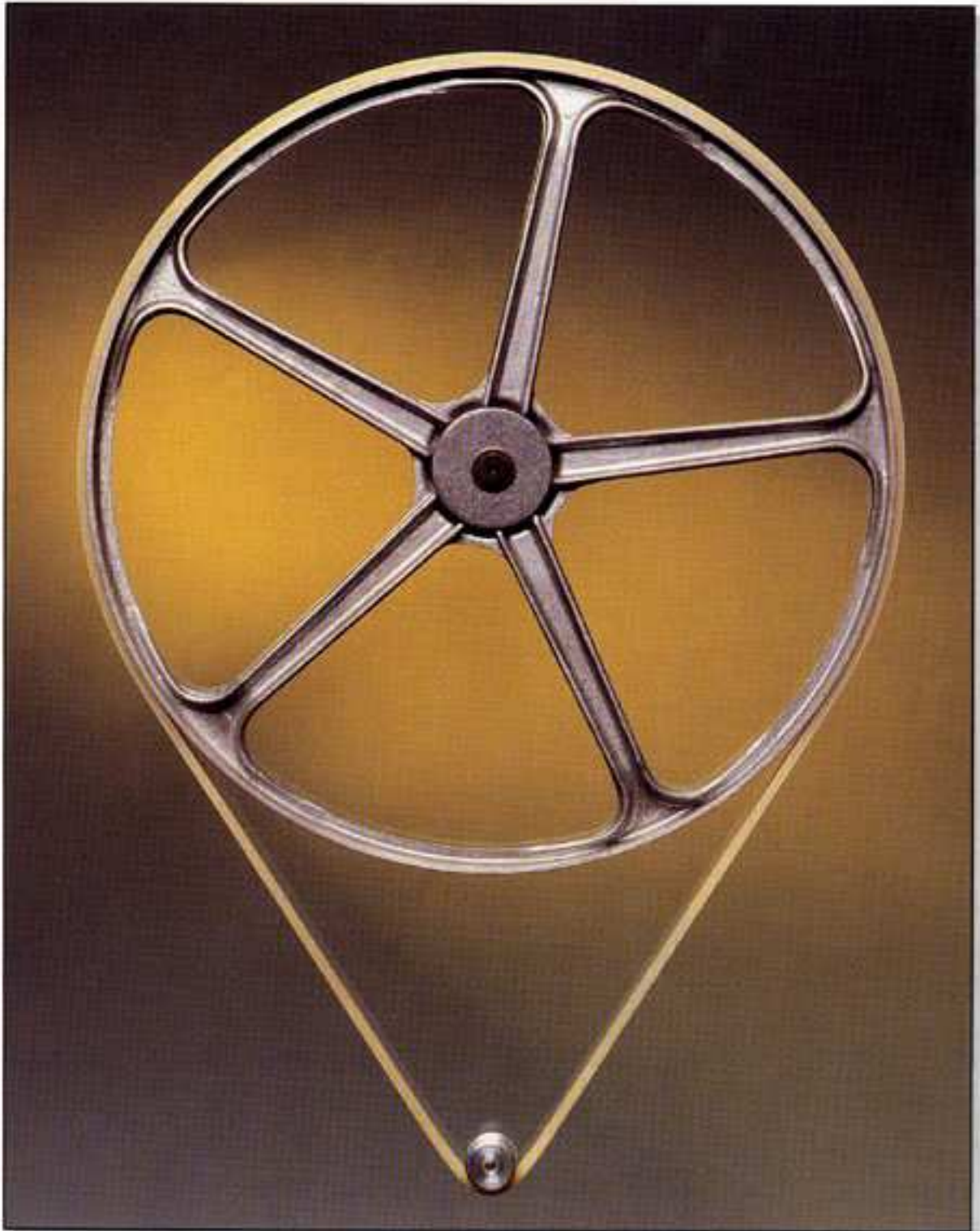

TRANSMISSION CALCULATION



The perfect efficiency of the power transmissions is influenced by several factors. That's why we have designed this catalogue section, fully dedicated to the transmission calculation, in order to allow a simple and easy consultation of the data.

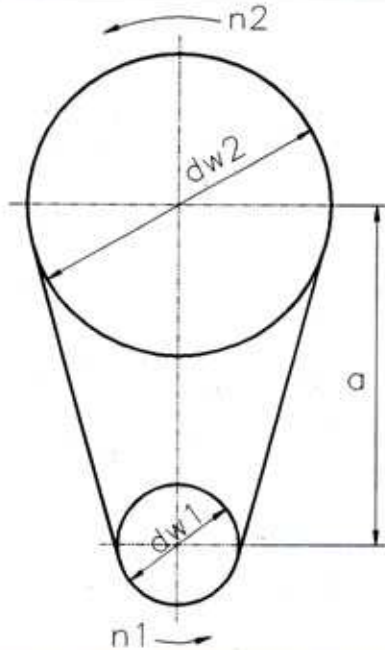

Legend

Symbol	Unit	Definition
a	mm	centre distance
c_1		service factor
c_2		correction factor for arc of contact
d_1	mm	pitch diameter of driver pulley
d_2	mm	pitch diameter of driven pulley
i		speed ratio
L	mm	belt length
n_1	min^{-1}	r.p.m. of driver pulley
n_2	min^{-1}	r.p.m. of driven pulley
P	kW	power to be transmitted
P_R	kW	power rating of the belt
v	m/s	belt speed
z		number of ribs
β	$^\circ$ (degrees)	arc of contact on small pulley
F_U	N	effective pull
F	N	traction load per rib

FORMULAE

$$a \sim 0.25 \cdot [L_w - \pi / 2 \cdot (d_{w1} + d_{w2}) + \sqrt{[L_w - \pi \cdot (d_{w1} + d_{w2}) / 2]^2 - 2 \cdot (d_{w2} - d_{w1})^2}] \text{ [mm]}$$

$$L_w \sim 2 \cdot a + \pi / 2 \cdot (d_{w1} + d_{w2}) + [(d_{w2} - d_{w1})^2 / 4 \cdot a] \text{ [mm]}$$

$$\beta = 2 \cdot \arccos [(d_{w2} - d_{w1}) / 2 \cdot a] \text{ [}^\circ\text{degrees]}$$

$$v \sim (\pi \cdot n \cdot d_{w1}) / (60 \cdot 10^3) \text{ [m/s]}$$

$$z = (P \cdot c_2) / (P_R \cdot c_1)$$

$$F_U = (P \cdot 10^3) / v \text{ [N]}$$



TRANSMISSION CALCULATION

Service factor

C₁	1 Light duty	- no peak load; up to 6 working hours a day
	1,2 Medium duty	- peak loads or starting loads 150% of full load; up to 16 working hours a day
	1,4 Heavy duty	- peak loads or starting loads 250% of full load; up to 24 working hours a day

Correction factor for arc of contact

C₂	Arc of contact on the driver pulley															$\beta = 2 \cdot \arccos [(d_2 - d_1) / 2 \cdot a]$ [°degrees]															
	90°	100°	110°	120°	130°	140°	150°	160°	170°	180°	190°	200°	210°	220°	230°	240°	0,61	0,67	0,71	0,76	0,79	0,84	0,88	0,92	0,97	1	1,03	1,07	1,09	1,12	1,15

Power Rating of the belt [kW per rib]

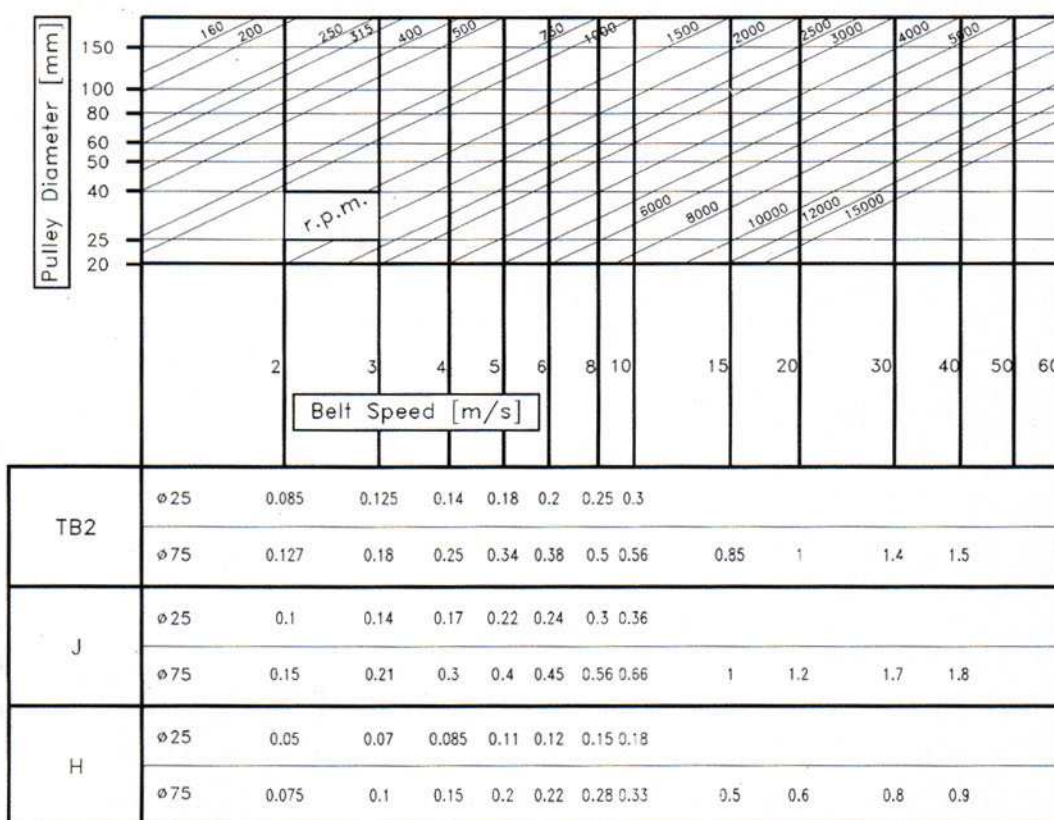

**Recommended installation tension per cm belt width for the endless form 300 N
Length elongation with recommended tension 0,7%**