

HAMILTON

THE MEASURE OF EXCELLENCE™

Digital Syringe™

Congratulations! You have purchased the finest quality precision fluid measuring device available today. We at Hamilton Company combine top quality materials with skilled workmanship, ensuring the highest possible performance level of every precision fluid handling device we manufacture. With proper care and handling, the Digital Syringe will provide unsurpassed performance in precision liquid handling year after year.

The Digital Syringe is a calibrated device composed of a serialized syringe and a serialized digital electronic holder. A certificate of calibration accompanies the unit. A digital readout allows enhanced syringe volume readability, while an adjustable plunger stop assures accurate, reproducible sample injections. The device also reduces the possibility of plunger bending. Suggested uses of the Digital Syringe include standard and sample preparation, GC injection, HPLC partial loop filling, titration, and calibration of gas analyzers.

Hamilton's Digital Syringe is available with 700 series MICROLITER™, 1700 series GASTIGHT™, and 7000 series MODIFIED MICROLITER™ syringes. The Digital Syringe is factory calibrated for precision measurements, and operates with a standard 3 VDC battery.

CALIBRATION OF THE DIGITAL SYRINGE

The syringe model you selected when ordering your digital syringe is installed onto the digital electronic holder, and the unit is calibrated at the factory. A certificate of calibration, indicating accuracy, is shipped with the Digital Syringe.

While it is physically possible to make syringe changes and syringe repairs on site, any syringe alterations other than RN needle replacement (or plunger replacement for GASTIGHT syringes), will necessitate recalibration of the Digital Syringe.

The Digital Syringe must be returned to the factory for periodic calibration and syringe replacement.

WARRANTY STATEMENT

Hamilton Company unconditionally guarantees its products to be free of defects in materials and workmanship. Any product which fails due to such defects will be repaired or replaced at our discretion without cost, provided the device is returned with an explanation. It is the responsibility of the purchaser to determine the suitability of application and material compatibility of the products based on the published specifications of the products.



Syringes and needles manufactured by Hamilton Company are intended for scientific research and laboratory use only and are not intended for human in vivo use.

FEATURES OF THE DIGITAL SYRINGE

Digital Display - The digital display consists of an LCD that shows information from the current display mode (see Figure 1). There are six descriptive parts to the LCD: **series** indicates the syringe series in use; **size** indicates total syringe volume; **hold** freezes the current volume display; **■** indicates that the battery voltage is low and the battery needs to be replaced; **μl** indicates that the displayed information is in units of microliters (μL); and **a negative sign** indicates plunger travel beyond the display zero.

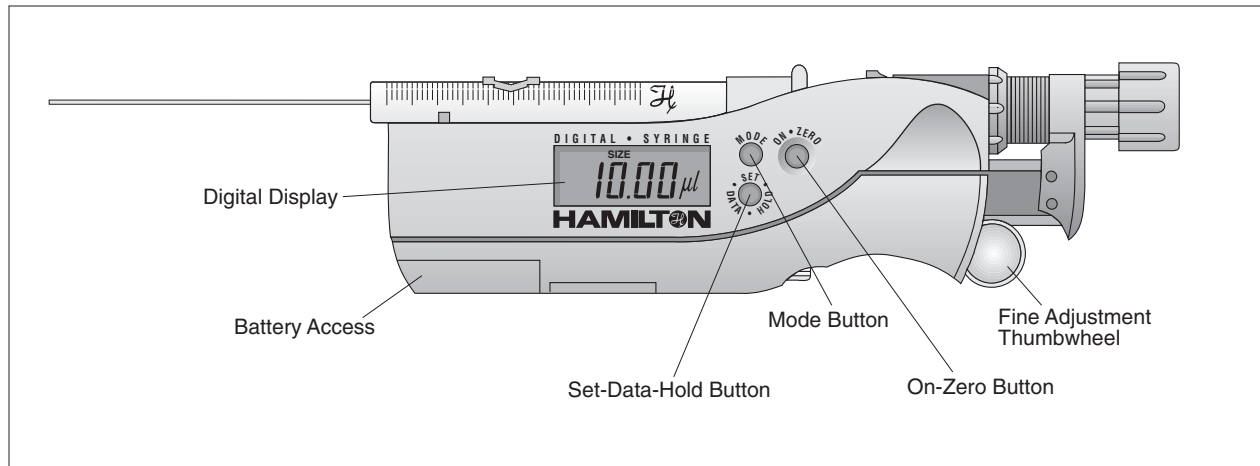

Figure 1

On - Zero Button - Turn on the unit by pressing the on-zero button (see Figure 1). This will activate the digital display. If the display is already on, pressing the on-zero button will zero the digital readout, regardless of the position of the plunger. Any subsequent movement of the plunger will result in a changing digital readout. If dispensing starts immediately after pressing the on-zero button, the display will indicate a negative volume.

Mode Button - Use the mode button to gain access to three descriptive functions of the digital display. Mode 1 (volume display) is the primary display mode, indicating the current volume dispensed or to be dispensed (Figure 2a). Press the mode button to view mode 2 or syringe series (Figure 2b). The syringe series shown should match that marked on the syringe barrel. Press the button again to view mode 3 or total syringe volume (size) (Figure 2c). Any time the battery is removed or replaced, you will need to reset the values in modes 2 and 3 to match your syringe. Change the mode settings using the set-data-hold button described below. When the LCD indicates an error message, the mode button is not functional.

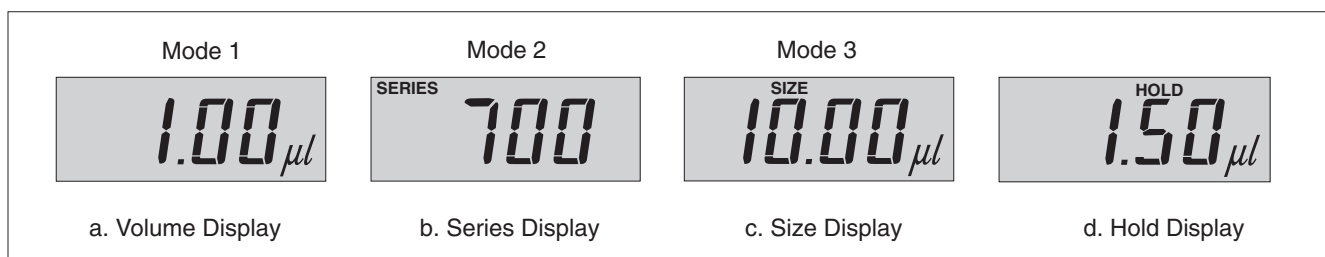

Figure 2

Set - Data - Hold Button - Change mode settings using the set-data-hold button. Press the mode button until the desired mode appears on the LCD. Then press the set-data-hold button until the desired setting appears on the display. Press this button repeatedly to scroll through available syringe series and syringe volumes. Pressing this button while in mode 1 freezes the current volumetric display and the word **HOLD** will appear on the LCD (Figure 2d). As an example, after you fill your syringe to the desired volume, press this button to freeze the display. You may then dispense the sample, and the volume dispensed still appears for recording. Press the button again to release the hold function.

Battery and Battery Access - Two +3 VDC batteries (Hamilton P/N 6509006) are supplied with the Digital Syringe, each having a life of about 1,000 active hours. After about 850 hours of operation, the low battery icon (■) appears in the upper right-hand corner of the digital display. The battery will continue to work for about 150 hours. The unit goes into an automatic battery idle mode after five minutes of no operation. All memory is retained unless the battery is removed. The battery is held in place on a slide-out tray located below the left-hand side of the digital display (see Figure 1). Only one battery is required for operation of the Digital Syringe, and it is installed during calibration at the factory. Should you have to replace the battery, you will have to reset the values in modes 2 and 3 (syringe series and size).

To install the battery, turn the Digital Syringe so that the Hamilton serial number plate faces you. Pull out the battery tray. Place the tray on a flat surface, and place the battery into the tray with the printed side down. Replace the tray with the battery into the Digital Syringe body. Make sure the syringe plunger is bottomed out in the syringe barrel, and turn on the unit by pressing the on-zero button.

Fine Adjustment Thumbwheel - Move the plunger in fine increments for a better position or volume control.

Plunger Drag Adjustment and Plunger Brake - Change the force or drag needed to actuate the syringe plunger. Turn the slotted plunger drag adjustment and plunger brake button (see Figure 3) clockwise to increase tension; turn the button counterclockwise to decrease tension. Press the button to activate the plunger brake at any time during the dispense operation.

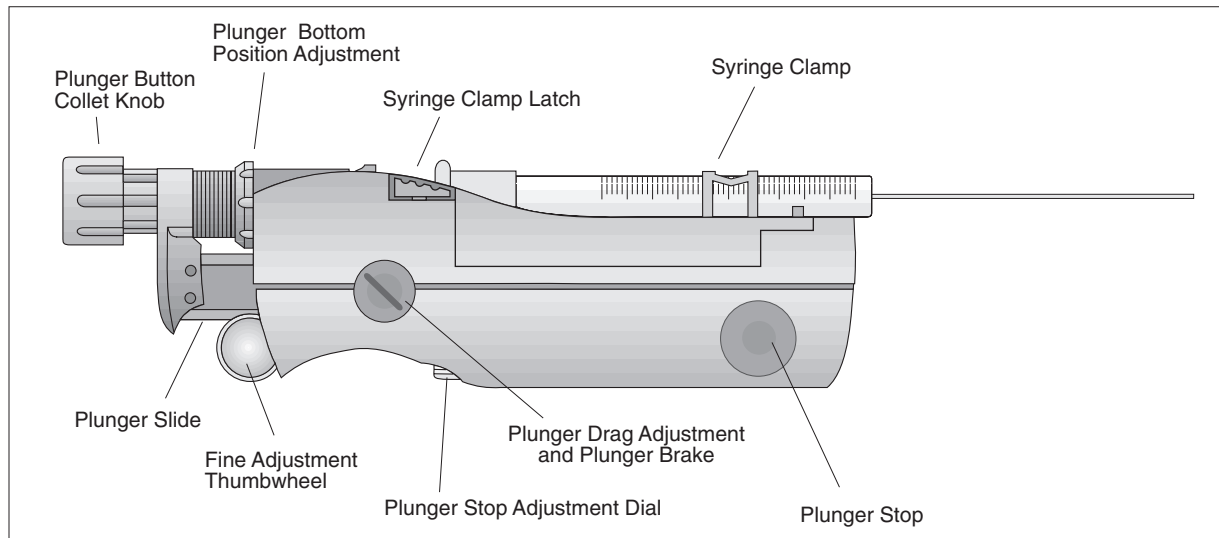

Figure 3

Plunger Stop and Plunger Stop Adjustment Dial - Repeat exact-volume filling of your syringe by pressing the plunger stop while pulling out the plunger slide until it stops at a preset value. Or, if you prefer, repeat exact-volume dispensing by first pulling out the plunger slide to the maximum syringe volume. Then press the plunger stop while advancing the plunger slide. The plunger will stop at the preset value. See "Operation of the Plunger Stop and Plunger Stop Adjustment Dial" on page 4 for more detail.

Syringe Clamp and Syringe Clamp Latch - The syringe clamp firmly holds the syringe barrel in place. Press the syringe clamp latch to remove the syringe for cleaning.

Plunger Bottom Position Adjustment - The plunger bottom position adjustment (Figure 3) allows you to position the plunger so that it will not bottom in the barrel, thereby avoiding potential damage to the syringe.

Plunger Button Collet Knob - Secure the plunger button by tightening the plunger button collet knob (Figure 3). Loosen this knob when removing the syringe from the digital electronic device.

OPERATION OF THE PLUNGER STOP AND PLUNGER STOP ADJUSTMENT DIAL

The Plunger Stop and Plunger Stop Adjustment Dial are used to set a volume for repeated dispensing, and to increase the precision of the Digital Syringe. To use this feature, choose method 1 for the most precise results; use method 2 for larger volumes and only after priming the syringe by aspirating and dispensing several times.

Method 1

1. Determine the volume at which the Plunger Stop is set.
 - a. Pull the plunger beyond maximum volume, and push and hold the Plunger Stop.
 - b. While holding the Plunger Stop, push the Plunger Button Collet Knob until the plunger stops.
 - c. Release the Plunger Stop, and read the digital display.
2. If the Plunger Stop is not at the desired volume, rotate the Plunger Stop Adjustment Dial (+/-) in the desired direction. One increment of turn is about equal to 1% of full syringe scale. Repeat step 1 to determine the new setting. Repeat steps 1 and 2 as many times as necessary to achieve the desired setting.

Note: As you turn the dial, the reading on the digital display will not change. Only when you repeat step 1 will you get a reading for the new setting.

3. Dispense the sample:
 - a. Aspirate a volume of sample greater than that to be used, and push and hold the Plunger Stop.
 - b. While holding the Plunger Stop, push the Plunger Button Collet Knob, dispensing the excess sample, until the plunger stops.
 - c. Release the Plunger Stop, and dispense the remaining volume.

Method 2

1. Determine the volume at which the Plunger Stop is set.
 - a. Push and hold the Plunger Stop.
 - b. While holding the Plunger Stop, pull the Plunger Collet Knob until the plunger stops.
 - c. Release the Plunger Stop, and read the digital display.
2. If the Plunger Stop is not at the desired volume, rotate the Plunger Stop Adjustment Dial (+/-) in the desired direction. One increment of turn is about equal to 1% of full syringe scale. Repeat step 1 to determine the new setting. Repeat steps 1 and 2 as many times as necessary to achieve the desired setting.

Note: As you turn the dial, the reading on the digital display will not change. Only when you repeat step 1 will you get a reading for the new setting.

3. Dispense the sample:
 - a. Push and hold the Plunger Stop.
 - b. While holding the Plunger Stop, aspirate the sample until the plunger stops.
 - c. Release the Plunger Stop, then dispense the syringe contents.

ERRORS

The message "ERR#" is displayed on the LCD when an error occurs. Errors may be caused by moving the plunger too rapidly, moisture or dirt on the surface of the plunger slide, or incorrect syringe installation.

To correct errors, clean and dry the plunger slide, and press the on-zero button.

If the unit does not respond, reinstall or replace the battery. If the battery is removed, you will need to reset syringe series and size using the mode and set-data-hold buttons.

SYRINGE REMOVAL AND INSTALLATION

To remove the syringe:

1. Release the plunger button by turning the Plunger Button Collet Knob counterclockwise.
2. Release the Syringe Clamp Latch by pressing down on it until the clamp snaps free. Lift the clamp and remove it if necessary.
3. Pull the plunger slide back to its maximum position, and remove the syringe.

To install the syringe:

1. Pull back on the Plunger Button Collet Knob to the maximum plunger slide position.
2. Release the Syringe Clamp and lift.
3. Position the syringe (with plunger fully inserted) over the slot above the LCD so that the syringe scale faces the same direction as the LCD. Push the syringe barrel into the slot making sure the barrel flange is captured between the flange pocket and the flange spring.
4. Press down the Syringe Clamp Latch until it catches.
5. Unscrew the Plunger Button Collet Knob, and push down the Plunger Slide so that the collet surrounds the plunger button.
6. Tighten the Plunger Button Collet Knob until it grabs the plunger button snugly. Do not overtighten.
7. Set the Plunger Bottom Position Adjustment so that it comes in contact with the Digital Syringe body just as the plunger bottoms out.

CLEANING AND MAINTENANCE OF THE DIGITAL SYRINGE

Clean the syringe after each use. Remove it from the Digital Syringe if necessary following the removal instructions provided.

To clean syringes it is best to use solvents known to be effective in dissolving the sample and preferably those that are non-alkaline and non-phosphate based. A biodegradable, non-phosphate, organic cleaning concentrate is available from Hamilton (P/N 18311). Rinse the syringe thoroughly with either high quality water or acetone.

To clean the plunger for 700 Series MICROLITER and 1700 Series GASTIGHT syringes, remove it from the syringe barrel and gently wipe it with a lint-free tissue. Reinsert the plunger. Remember to wet the PTFE plunger tip of a GASTIGHT syringe before inserting the plunger into the barrel.

To clean 7000 Series MODIFIED MICROLITER syringes, do not remove the plunger assembly. Flush the syringe several times with cleaning solvent, and several times with high quality water.

An alternate cleaning method for any of the syringes is Hamilton's Syringe Cleaner . This is a dry method of cleaning that is normally sufficient to vaporize most common liquid samples. You may include a vacuum source, if necessary, to remove suspected residuals.

Whenever needed, wipe the digital electronic device with a soft cloth wetted with water, a dilute bleach solution, or other compatible decontamination solution. Thoroughly dry the device before reinstalling a syringe or operating the unit.

Periodically clean the Plunger Slide by gently wiping it with a soft cloth moistened with water or isopropyl alcohol. Thoroughly dry the plunger slide before operating the unit. Occasionally you may need to lubricate the plunger slide by wiping it with a soft cloth moistened with a light oil. Do not leave excess oil on the slide surface that would tend to accumulate dirt. After applying the lubricant, wipe the surface of the Plunger Slide with a dry cloth, leaving only a very thin film of the oil.

Refer other maintenance questions, concerns, or problems to Hamilton Company.

DIGITAL SYRINGE STORAGE

Store the Digital Syringe in a location that is free of vibration. The Digital Syringe goes into an automatic battery idle mode (the digital display is no longer active) after five minutes of no operation. However, low level, high frequency vibrations can cause the device to remain on. This reduces battery life.

If you are in doubt about vibrations in your storage location, check the Digital Syringe after 5 to 10 minutes of no operation to make sure the digital display is no longer active.

DIGITAL SYRINGE RECALIBRATION

Hamilton Company recommends annual recalibration of the Digital Syringe. However, it can be calibrated as often as your procedures require.

To have your Digital Syringe recalibrated, complete the information on the Recalibration Card enclosed with the shipping documents, and return the unit to Hamilton Company. If the Recalibration Card is missing, contact Hamilton Company.

REGULATORY INFORMATION

The Digital Syringe generates and uses radio frequency energy, and may interfere with radio and television reception. The Digital Syringe complies with Class B limits as specified in Subpart J of Part 15 of FCC Rules, which provide reasonable protection against such interference.

In the unlikely event there is interference to radio or television reception, try reorienting the receiving antenna or relocating the Digital Syringe relative to the receiver.

The Digital Syringe complies with EN55011 (1998 A2: 2002), "Electromagnetic Emissions" and EN 61326-1 (1997 A2: 2001), "Radiated Susceptibility."

Return of Goods

Hamilton Company's return and repair policy is written to protect its employees from potentially hazardous materials (e.g., serum, radioactive materials, carcinogenic chemicals, etc.) or any substance that may cause them partial or permanent disability during the inspection or repair process. In returning a product, the customer acknowledges that the product is free from any hazardous materials. Furthermore, the customer assumes responsibility should the returned product be determined to be hazardous.

Trademarks:

GASTIGHT, MICROLITER, MODIFIED MICROLITER, and Digital Syringe are trademarks of Hamilton Company.



HAMILTON
THE MEASURE OF EXCELLENCE™

Hamilton Company
4970 Energy Way
Reno, Nevada 89502 USA
Toll-Free: 800-648-5950
Telephone: +1-775-858-3000
Fax: +1-775-856-7259
e-mail: oem@hamiltoncompany.com

Hamilton Bonaduz AG
Via Crusch 8
CH-7402
Bonaduz/Switzerland
Telephone: +41-(0)81-660-60-60
Fax: +41-(0)81-660-60-70
e-mail: marketing@hamilton.ch

www.hamiltoncompany.com

Doc. No. 69191 (Rev. F) © Hamilton Company 4/08 Printed in U.S.A.