



Levelstate Systems Ltd.



**INSTALLATION, OPERATION & MAINTENANCE  
MANUAL FOR  
ELECTRONIC DRUM LEVEL INDICATOR  
TYPE – 201**

ISSUE I : MARCH 2009

Little Kitfield, Gradwell Lane, Four Marks, Hampshire GU34 5AS, U.K.

Tel: +44 (0) 1962 773829 Fax: +44 (0) 1962 773849

E-mail: [info@levelstate.com](mailto:info@levelstate.com)

Web: [www.levelstate.com](http://www.levelstate.com)

© 2009 Levelstate Systems Ltd.

All rights reserved

With technical progress the company reserves the right to change specifications without notice.

***Solution at all levels***

## TABLE OF CONTENTS

<u>Section</u>	<u>Page</u>
Boiler Codes or Standards – Summary of Requirements	3
<b>1. Operating Principle</b>	4
<b>2. General Configuration</b>	6
2.1 Trip Circuits	11
2.1.1 Low Level Trip	12
2.1.2 High Level Trip	13
2.1.3 Alarm Circuits	13
<b>3. Installation &amp; Cabling</b>	14
3.0 General	14
3.1 Water Column & Probe	15
3.2 System Cabling	18
3.3 Electronic Unit	21
3.4 Remote Display	24
<b>4. Commissioning</b>	25
4.1 Probes	25
4.2 Electronic Unit	26
4.3 Water Column	27
<b>5. Maintenance &amp; Fault Identification</b>	28
5.1 Pressure Parts	28
5.2 Electronic Unit	31
5.3 Fault Identifications Procedure	32
<b>6. Electronic Unit</b>	34
6.1 201 EDLI Parts List	39
<b>7. System Specification</b>	40

<b><u>Figs</u></b>		<b><u>Page</u></b>
1.1	Sensing Element	4
1.2	Water Level Monitoring	4
1.3	Conductivity Chart	5
1.4	Conductivity Graph	5
2.0	System Configuration	8
2.1	Side Arm Water Column	9
2.2	Probe Types 801, 802 and 803	10
3.1.1	Water Column Installation	16
3.1.2	Water Column Support Structure	17
3.2.1	System Cabling	19
3.2.2	Probe Routing on Water Column	20
3.2.3	Cable Gland Allocation	20
3.3	Electronic Enclosure Fixings	23
3.4	Remote Display Fixings	24
5.3.3	Fault Identification Procedure	33
6.0	Electronic Enclosure Layout	35
6.1	PCB1 Component Layout	36
6.2	PCB2 Component Layout	37
6.3	PCB3 Component Layout	38

## **Boiler Codes or Standards – Summary of requirements**

### **ASME Boiler Code**

Boilers must have one gauge glass. Above 400psi operation two gauge glasses shall be provided. For boilers with safety valves set at or above 900psi two independent remote level indicators may replace one of the two gauge glasses. If both remote indicators are in reliable operation the remaining gauge glass may be valved off but must be maintained in serviceable condition.. **If gauge glasses are not visible to the operator two dependable Indirect Indicators shall be provided.** The lowest visible level of the gauge shall be at least 2” above the lowest permissible water level where there is no danger of overheating any part of the boiler. Each water gauge glass shall be equipped with a top and bottom shutoff valve of through flow construction to prevent stoppage by deposits of sediment. Straight run globe valves shall not be used. Connections from the boiler to the remote level indicator shall be at least 0.75” pipe size including isolation valves. For gauge glasses connected to the boiler the steam and water connections shall not be less than 1” pipe size. There shall be no sag or offset in the steam pipe and no part of the water connection shall be above the point of connection to the gauge.

It is recommended that each boiler have two independent low water cut-offs. The permanent installation of cutout devices for low water cut-offs should not be provided: temporary devices can be installed for testing.

### **British Standard BS759. Part 1. 1984**

Boilers shall have two independent gauge glasses each capable of being isolated from the boiler. One water level gauge is permitted for boilers of less than 145kg/h evaporative capacity. For boilers with safety valves set at or above 60bar in two independent manometric remote level indicators may replace one of the gauge glasses. One gauge glass with its isolating valves shall be connected directly to the boiler. **Remote level indicators that have been approved by an “Inspection Authority” may replace gauge glasses.**

The lowest visible level of the gauge shall be at least 50mm above the lowest permissible water level where there is no danger of overheating any part of the boiler. Steam and water isolating valves if straight pattern globe type shall be mounted with the spindle horizontal.

The bore of steam and water connections shall be not less than 25mm. local to fittings not less than 20mm. The level gauges shall be mounted as close as is practical to the boiler shell or drum.

Automatic controls shall effectively shut off the fuel supply in the event of low water level.

There is a reasonable degree of commonality between the above requirements and this is generally reflected in other National regulations. Accepted or recognized standards must be used for the design material selection welding and inspection of pressure containing components.

## 1.0 Operating Principle

The Levelstate type 201 System is an electronic alternative to the gauge glass providing a significant improvement in accuracy, visibility, reliability and safety, enabling transmission of the water level condition to a remote display and the application of alarm and control functions.

The discrimination between water and steam is based on the significant difference in resistivity between the two states over the saturation range. The sensing element is a Probe with an insulated tip inserted in a side-arm water column FIG 1.1. If a voltage is applied to the tip, conduction occurs between the tip and the inside wall of the column. The dimensions are selected to provide a resistance typically less than  $100\text{K}\Omega$  when the Probe is immersed in water, which results in a resistance greater than  $5\text{M}\Omega$  for the steam condition. An electronic discrimination circuit is arranged to sense whether the Probe resistance is less than  $100\text{K}\Omega$  representing water or greater than  $100\text{K}\Omega$  representing steam.

With 12 Probes spaced vertically in a side-arm vessel attached to the boiler FIG 1.2 and with each Probe connected to its own sensing and water/steam indication circuit a vertical display of 12 Green/Red indicators provides sufficient resolution for water level indication. The spacing between Probes is chosen to cover the required Sight-Range.

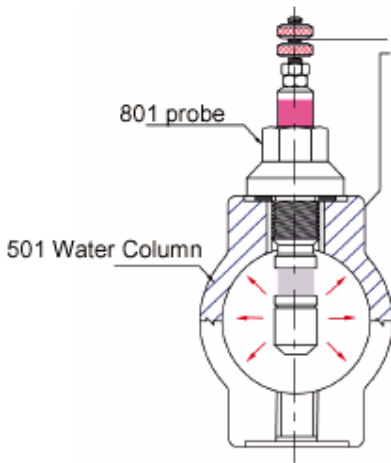


Fig. 1.1

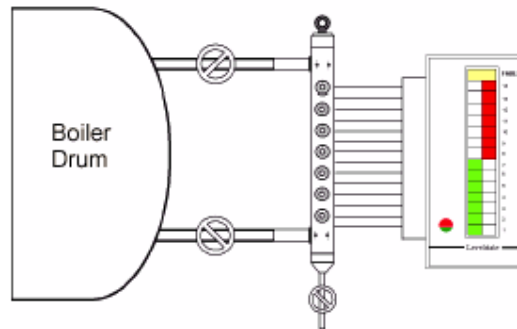


Fig. 1.2

Typical water conductivities are shown in Fig 1.3. The definition of the various categories is indicated at the top.

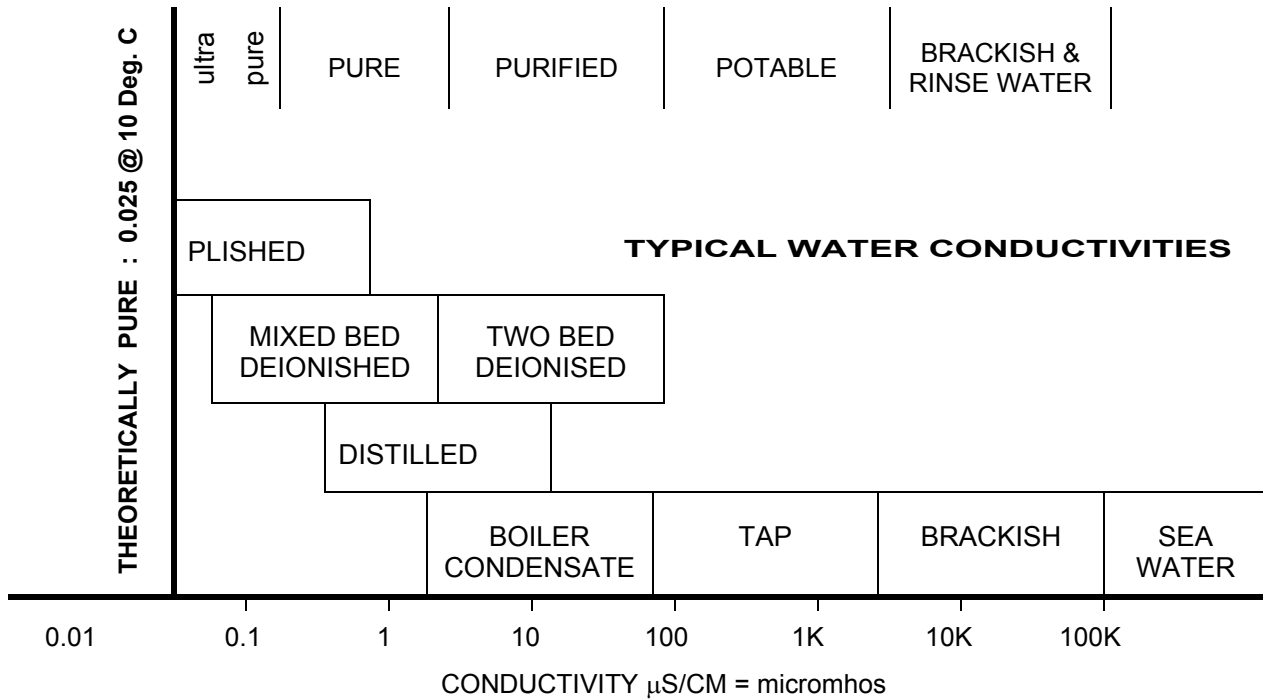


Fig. 1.3

Fig 1.4 below shows the relationship between boiler water resistivity (the inverse of conductivity) and boiler drum pressure. The side-arm column purposely stimulates condensate flow and this flushing effect result in the column water being purer than the water in the drum. As the pressure increases, the water resistivity increases and it is essential that the water/Steam switching threshold lies above the side-arm water resistivity for the maximum boiler pressure encountered. On the other hand it is advisable to use as low a resistivity-switching threshold as possible to render the system less susceptible to switching due to moisture and water droplets.

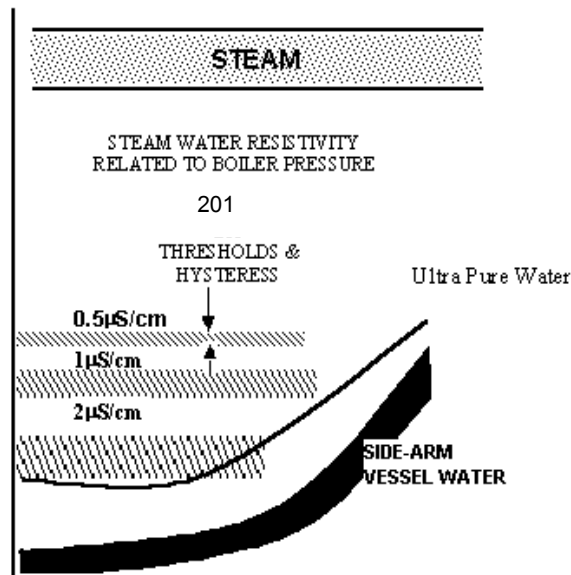


Fig. 1.4

## 2.0 General Configuration Fig 2.0

The 12 Probes are installed in a side-arm water column in two staggered vertical rows, numbered from the bottom; the ODD numbered probes are located on one side of the column and the EVEN numbered probes on the opposite side. Or in the same side of water column. A typical Water Column is shown in Fig 2.1 and the Probe detail in Fig. 2.2.

Two printed circuit boards contained in an IP65 (NEMA 4X) wall mounted enclosure provide 12 discrete water/steam discrimination circuits, LED display, relay alarm outputs, and terminals for the connection of a Remote Display Unit.

Generally the water column is aligned for Normal Water Level (NWL) located between Probes 6 and 7, with the lower six probes *normally sensing water* and the upper six *normally sensing steam*.

As the steam condition presents a high resistance to the sensing circuit, which is indistinguishable from an open circuit connection, two wires are used on the probe channels normally sensing steam. If either wire is disconnected the sensing circuit indicates the Water State thus declaring the fault. For the single wire connection to the lower probe channels and open-circuit connection obviously indicates the Steam State at the channel output again declaring the fault.

For this standard arrangement a 20 core PTFE cable is provided for probe connections. For other situations terminals are provided on the 201 Unit for 2 Wire connections on channels 1 to 6.

To avoid galvanic action at the probe and variations in sensing voltage due to changing electrolytic potentials, an alternating voltage source is applied to the probe and the sensing circuit responds only to an alternating waveform. Two low frequency oscillators are provided for the source voltage, one driving the odd numbered channels and the other the even numbered channels. The voltage applied to the probe is less than 6 volts current limited to 50 microamps and presents no risk to personnel.

Collectively the discrimination or sensing channels may be set to one of three sensitivity selections for water conductivity.

Each channel output drives a Green LED for Water detected or a Red LED for Steam detected.

Two alarm relays RL1, RL2 with integral delays, may be programmed to any channel except 6 and 7. If more than one channel is linked to the RL1 or RL2 delay circuit either channel will initiate the delay relay action.

If a channel from 1 to 5 is linked and a channel from 8 to 12 linked to the same relay circuit the low channel will initiate relay action when steam is indicated (Lo Alarm) and the high channel will initiate action when water is indicated (Hi Alarm). This can provide a single Alarm contact for a combined Lo / Hi Level Alarm.

Additional two relays RL3, RL4 are included for instantaneous relay action whereby a 2 out of 3 probe channel voting logic is applied.

Relay action can be selected for **normally energized** or **normally de-energised** depending on the alarm/trip policy required..

A link –programming feature allows selected display LED's to flash on initiation of alarm relays. Any illuminated Red LED (Lo Water Level) on channels 1 to 5 and any illuminated Green LED (Hi Water Level) on channels 8 to 12 may be selected to flash when initiated by the delay circuit, which operates RL1 & RL2. An identical linking facility is also provided to flash LED's on the Remote Display Unit.



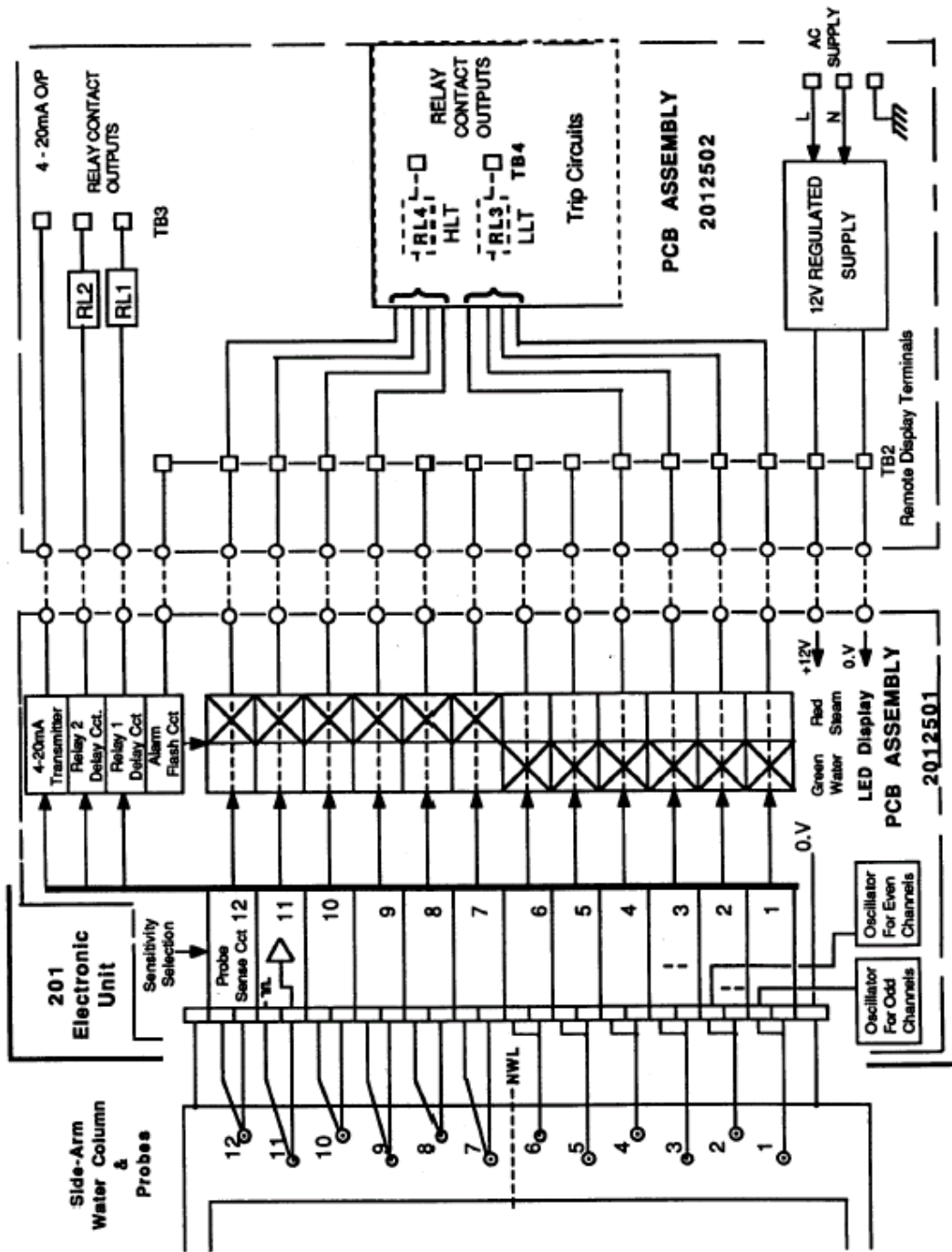
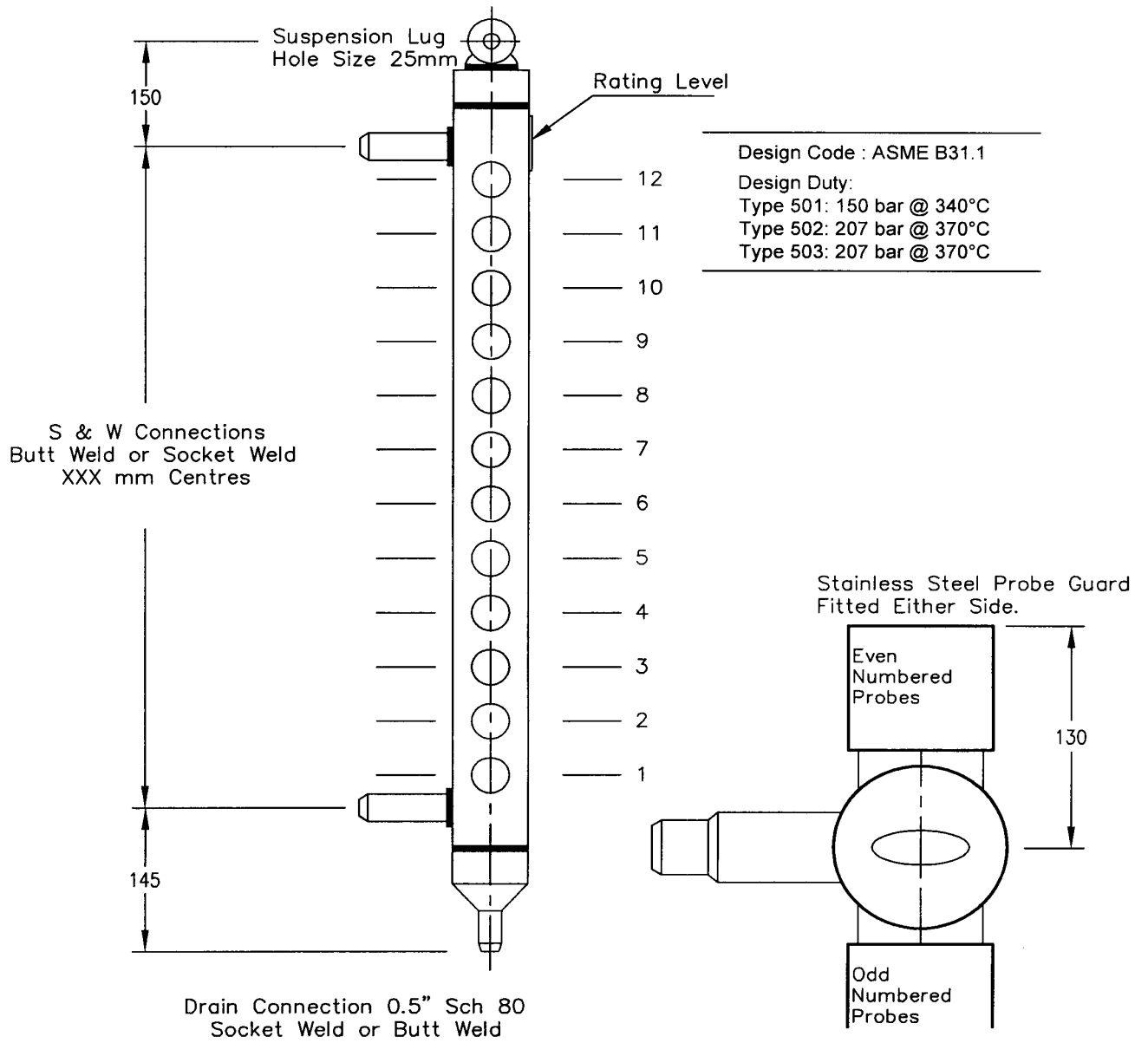


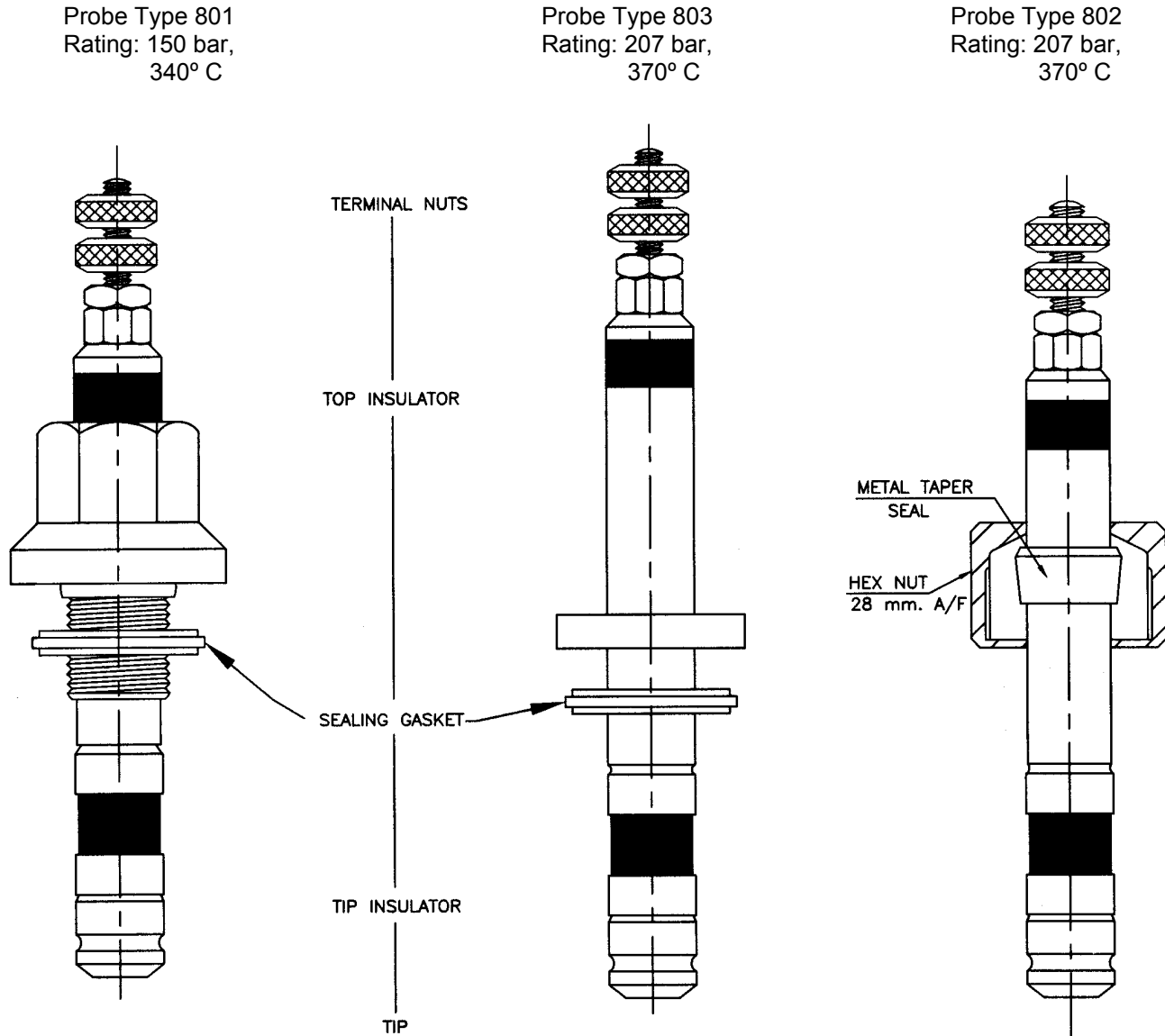
Fig. 2.0 System Configuration



**Fig. 2.1 Side-Arm Water Column**

**Probe Details :-**

The 201 system employs multiple probes installed in a vertical column, usually in two diametrically opposite rows. Three types of probes are available: (i) Type 801 – for pressure upto 150 bar; it is screwed directly into the Type 501 water column and is gasket sealed (ii) Type 802 – for pressure upto 207 bar; compression fitted to Type 502 water column and sealed by metal to metal contact and (iii) Type 803 – for pressure upto 207 bar; gasket sealed clamp plate type mounting onto Type 503 water column held in position by four studs and nuts. Both 801 and 803 probes use SS-grafoil Metaflex gasket seals as shown in Fig. 2.2



**Fig. 2.2 Probe Type 801, 803 and 802**

## 2.1 Boiler shut-down or trip circuits

Two low water level shutdown devices are a stipulated requirement in the regulations for the protection of steam raising boilers. Two remote level indicators may replace on gauge-glass; if a trip circuit is derived from each remote level indicator system the requirements may be satisfied.

For the practical application of shutdown systems the consequences of malfunction of the protection circuit must be considered when deciding which method of implementation is the most appropriate. If a relay is normally energised in the healthy state of the plant, supply failure or relay coil open circuit will obviously induce a spurious trip; if the relay is normally not energised, supply failure or relay coil open circuit prevents initiation of a required trip action. Similarly if a normally closed relay contact is used and a wire disconnection occurs a spurious trip is initiated. If a normally open contact is used a wire disconnection is not apparent and a trip requirement cannot be initiated.

The economics of Power Plant boiler operation dictates that spurious trips due to protection system fault must be minimised and the required degree of shut-down system "availability" must be achieved by duplication of protection devices. For smaller boilers the 'Recommendations' or 'Codes of Practice' specify that the boiler should be automatically shut down in the event of faults on low water level protection devices.

The protection system policy must first be established and the duplication and interconnection of the trip circuits organized to suit the requirements in terms of Reliability and Availability. When discussing industrial equipment performance the mere mention of 'failures' although rare in occurrence evokes Murphy's Law. It must be accepted that even with an extremely small failure rate of one in a million hours (probability of failing once in 114 years) if could happen tomorrow so however remote the probability the consequential effects of failures should be considered.

For the 201 System the prime failures which affect reliability are the following:-

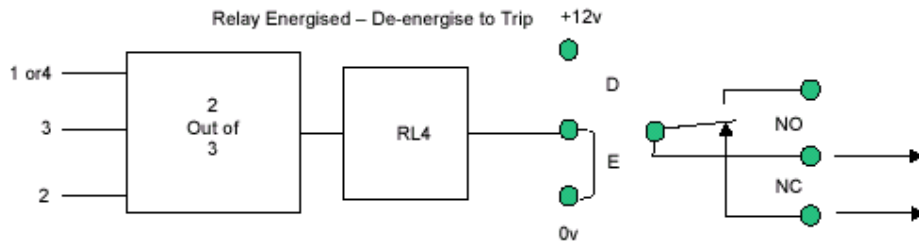
1. Mains Supply Source. If a highly secure instrumentation supply is available this should be used. If two Water Level Indicators are fitted they should be supplied from separate mains supplies.
2. Steam leaks from valves can cause level indication errors.
3. The prime failure of the Probe is to the water state due to the possibility of insulator contamination caused perhaps by poor control of boiler water quality. The water column intentionally simulated condensate flow through the system to reduce density errors but this also improves the water purity in the column preventing contamination. Failure of the pressure seal at the ceramic insulator generally causes the Water State to be indicated. For probes normally immersed in water at the lower levels this failure is not apparent and is only discovered when a low level occurs where a trip may be required. It is recommended that a test for this type of failure be performed at least every 6 months.

### 2.1.1 Low/High Level Alarm/Trip

For boilers many 'Operating Guidelines' or 'Codes of Practice' recommend that for low level tripping devices any equipment fault should initiate a boiler trip. This presumably applies to single element devices and does not reflect the fault tolerant approach of multi channel devices or the duplication of equipment.

With the prime failure mode of the Probe to the Water State and, for the lower Probes, a wire disconnection inducing the Steam State, there is some conflict in conforming to the above 'Guidelines'. For the 201 system a secure fault tolerant approach has been implemented whereby any 2 out of 3 Probe channels indicating the Steam condition will initiate a trip.

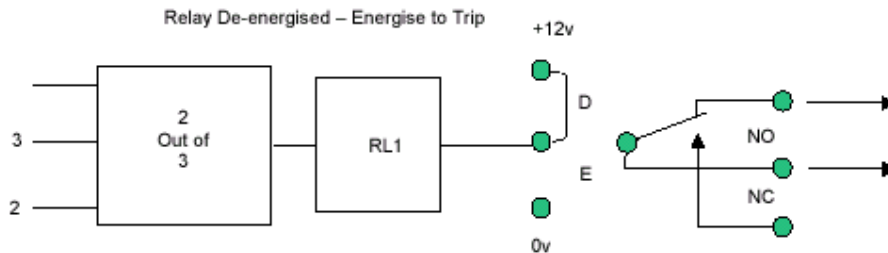
To satisfy the 'Guidelines' a normally energised relay with normally closed contacts should be used.



Spurious action of relay will be initiated for the following remotely possible failures.

- (a) Mains Supply failure or relay coil open circuit.
- (b) A disconnection in the wiring to the shutdown device.

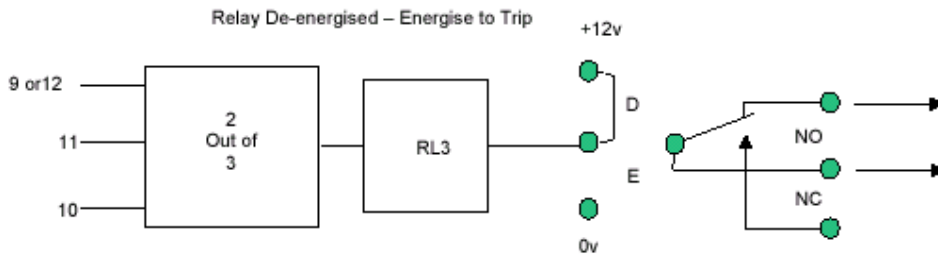
To avoid these spurious relay action the following circuit should be implemented where the relay is not energised and a normally open circuit connection to the shutdown device.



The problem here is the possibility of missing a necessary relay action if faults (a) and (b) ever occur, if a second water level indicator is fitted and supplied from a separate Mains Source and separately connected to the shutdown device the possibility of both systems failing simultaneously is so remote that it can be discounted provided any faults are corrected within a reasonable time.

### 2.1.2 High Level Trip

There are no 'guidelines for high level trips as the risks involved are not as disastrous - except for associated plant. However the 201 Unit also provides the security of the 2 out of 3 arrangement for the high level trip which is particularly important when applied to Feedwater Heater Level Monitoring.



RL1 and RL2 may be connected for two separate Lo or Hi alarms or one Lo and one Hi. More than one channel may be connected to each relay; this feature allows a configuration whereby a Lo and a Hi Probe channel connected to one relay provides a single output contact for a combined Lo / Hi Alarm.

**NOTE: Internal Test Switches SW1, SW2 do not inhibit operation of relays RL3, RL4. Inadvertent operation of these switches would induce a Trip Action. The Trip Circuits should be disarmed externally Before opening the 201 Enclosure.**

### 2.1.3 Alarm Circuits

Two relays RL1 and RL2 provide Alarm signaling and have integral delay action preset over the range 1 to 30 seconds. RL1 and RL2 may be connected for two separate Lo or Hi alarms or one Lo and one Hi. More than one channel may be connected to each relay; this feature allows a configuration whereby a Lo and a Hi Probe channel connected to one relay provides a single output contact for a combined Lo/Hi Alarm.

### **3 Installation & Cabling**

#### **3.0 General**

For Boiler applications the installation must conform to the accepted Regional or National Standards. Pipework connections must be welded, tested and inspected to the relevant procedures. Ensure that the appropriate Regulations are adhered to and procedures documented.

A typical Water Column Installation is shown in Fig. 3.1.1 and 3.1.2 but special versions may be required for particular applications. In all cases it is essential to achieve the minimum length of connecting pipework to the water column, this is to minimise density errors caused by heat loss. This produces a temperature difference and therefore a density difference between the water in the column and the water in the boiler or heat exchanger. In particular the lower water connection should be as straight as possible with a slight downward slope from the column to achieve good water circulation, preventing the accumulation of dissolved solids and avoiding the possibility of level indication errors. The top equalising connection should project inside the boiler shell to prevent surface condensate cascading down the pipework to the column, excessive water flow in the column causes a pressure drop resulting in level indication errors. Both steam and water shell tapping should terminate internally away from localized turbulence, which causes pressure differences, and therefore level indication errors.

For boiler applications where the inclusion of steam and water isolation valves is mandatory Fig. 2.1 provide connections for a side-arm arrangement similar to gauge glasses. With the inclusion of isolation valves the distance of the column from the boiler drum required the assembly to be supported by the top suspension lug of the column ensuring there is no differential expansion between the support structure and the boiler drum Fig 3.1.2.

If a boiler low or high water level trip circuit is connected to the 201 Electronic Unit it is recommended that all isolation valves are lockable in the open position and the drain valve lockable in the closed position to prevent spurious tripping by inadvertent valve operation.

The 201 Electronic Unit enclosure is usually sited adjacent to the Water Column within a distance suitable for the 4m length of special high temperature PTFE cable supplied. If longer cable lengths are required terminate the PTFE cable in a suitable water tight junction box and extend with standard 20 core stranded conductor instrumentation cable; ensure extension cable is protected from heat sources.

Siting of the 201 enclosures must consider adequate visibility of the display, the routing of other cables away from heat sources and the minimum risk of damage from surrounding plant or activities.

### 3.1 Water Column – Installation – general Requirements

- 3.1.1 For boiler side-arm columns Figs 3.1.1, 3.1.2 the support structure should be installed, the column attached by the top suspension lug and, in most cases, aligned with the drum NWL between Probes 4 and 5, Fig. 3.1.1. The support structure should be sufficient to take the weight of the column plus steam and water isolation valves, drain valves and pipework.

Parallel slide or gate valves should be used particularly for waterside isolation as they allow full bore opening without restricting water flow. Straight run globe stop valves **shall not be used (ASME)** but if permitted by other codes they must be mounted horizontally as shown. If the 201 System low and / or high water boiler trip circuit is used it is recommended that all isolation valves are lockable in the open position and the drain valves lockable in the closed position to prevent spurious tripping by inadvertent valve operation.

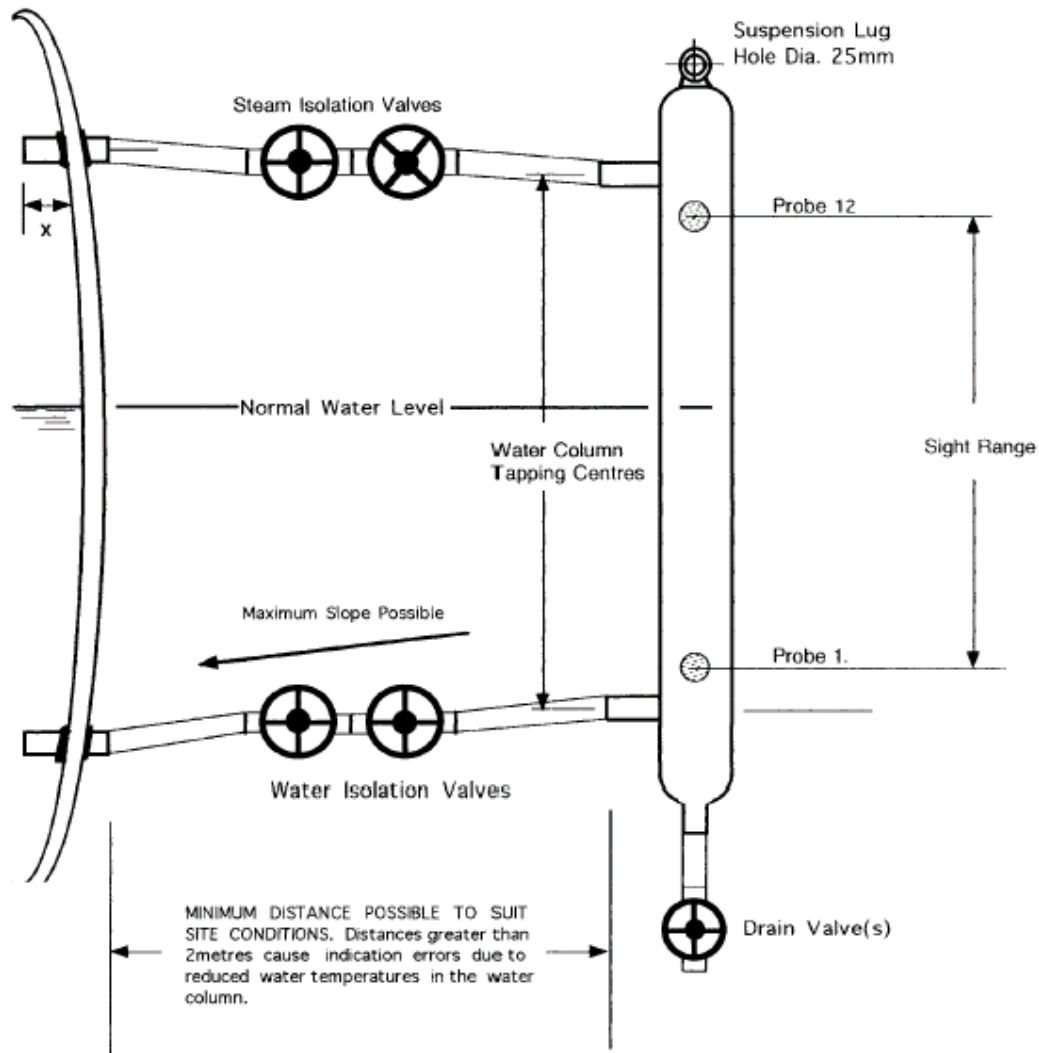
It is essential to ensure there is a continuous downward slope of at least 1:50 from the Water Column to the Boiler Drum to enhance water circulation. (ASME Code: No part of this water connection shall be above the point of connection at the Water Column. For the steam connection to the boiler there shall be no sag or offset in the piping, which shall permit the accumulation of water).

The column connections are profiled for butt weld fitting to pipework. If socket weld fittings are to use the 40° profile should be removed and the fittings supported to allow 2mm (0.08”) spacing to the fully seated position. After welding to documented procedures any temporary supports should be removed and alignment to NWL checked prior to weld inspection. Fit Guards to protect probe seating. Lag steam and water pipework and valves.

Before commissioning install Probe cable and shown in Fig. 3.2.2

**As a precaution ensure steam and water isolation valves are closed and drain valve open.**

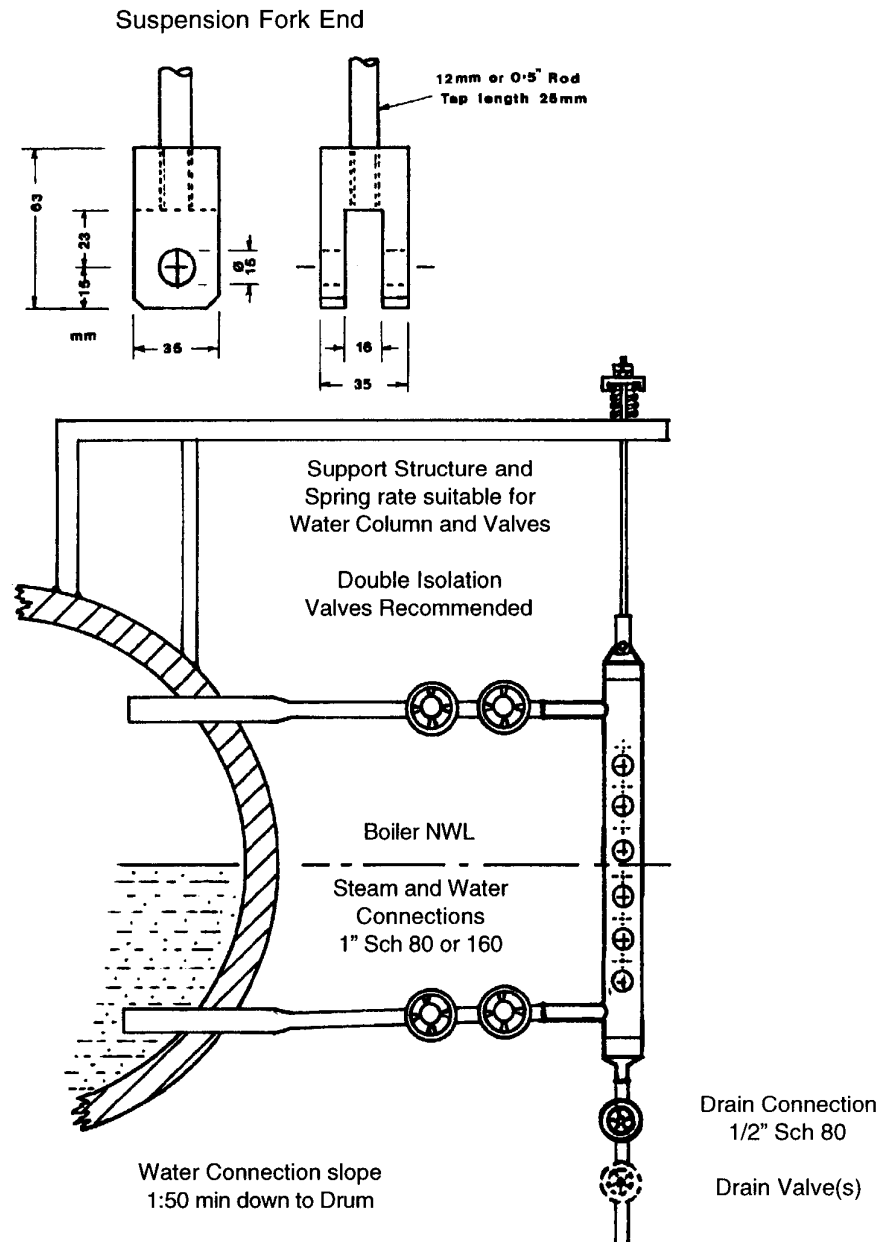




**Fig. 3.1.1 Water Column Installation**

1. The Water Column should be suspended such that there is no differential vertical movement between the Boiler Drum and the Column. Generally a spring suspension should be provided where the spring rate includes column, isolation valves, drain valves and associated pipework.
2. The lower water connection to the Column must be above the level of the connection to the Drum to prevent air locks. For the same reason the steam connection to the Column must be below the connection to the Drum. Preference should be given to the continuous slope of the water connection with no restrictions, to aid water circulation.
3. The water connection inside the Boiler Drum should avoid turbulence from down-comers, feedwater inlets etc. The steam connection should protrude sufficiently (X) to avoid drum surface condensate following to the Column
4. Procedures for site welding of pipework and valves must conform to the National or Accepted Standards for boiler applications.

5. Connection pipework and valves should be lagged to prevent heat loss.
6. Guards should be provided to prevent accidental contact with the Water Column; these should not restrict convection cooling of the Column.
7. Probes should not be fitted to the Column until mechanical installation and Drum cleaning processes are completed.



Water and Steam connections to be as short as possible to minimise heat losses and resistance to water flow

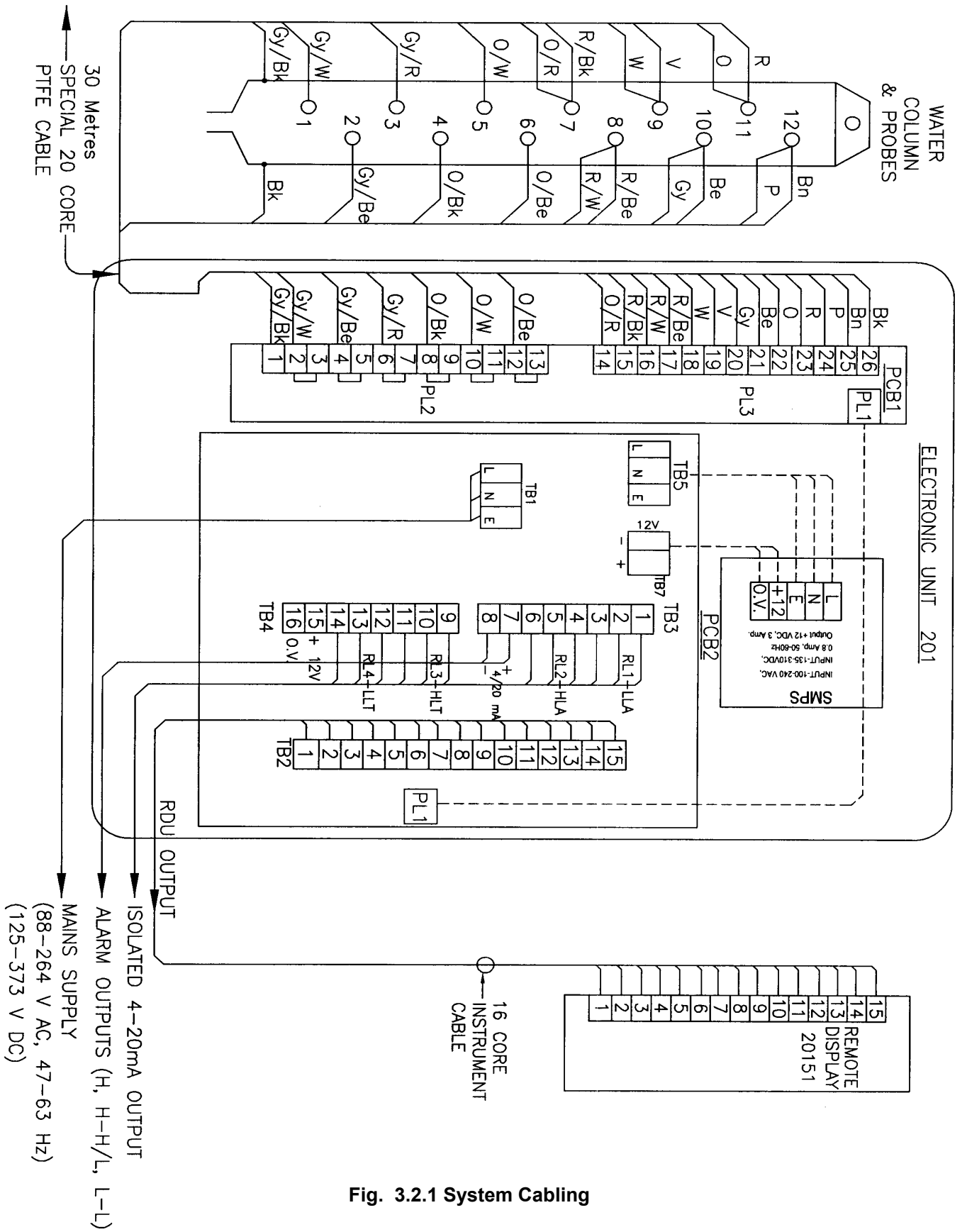
**Fig. 3.1.2 Water Column Support Structure**

### 3.2 System Cabling

Fig 3.2.1 shows the System Cabling requirements. Fig 3.2.2 shows Probe Cable Fixing on the water column and Fig. 3.2.3 Cable Gland allocation on 201 Unit.

A 4 metre (12") sheathed length of special 20 core high temperature PTFE cable is provided for Probe to 201 Unit connections. This cable is pre-formed for the standard vessel arrangement where NWL is between Probes 6 and 7. For longer cable lengths a junction box and standard PVC multi-strand instrument cable should be interposed in the run to the 201 Electronic Unit. The Water Column looming has been arranged for the cable to be clamped on the right hand side with the ODD numbered Probes on the left hand side and the EVEN numbered Probes on the right hand side. It is recommended that the cables are taped to the 6mm (1/4") vertical Tie Rods using 12 mm PRFE Thread Seal Tape (as used in pipe sealing Rs.512-238).

Cable for the Mains Supply, 20 Core Remote Display, Alarm and 4-20mA circuit are fitted as required using standard instrumentation cable through the 201 Unit Cable Glands as shown.



**Fig. 3.2.1 System Cabling**

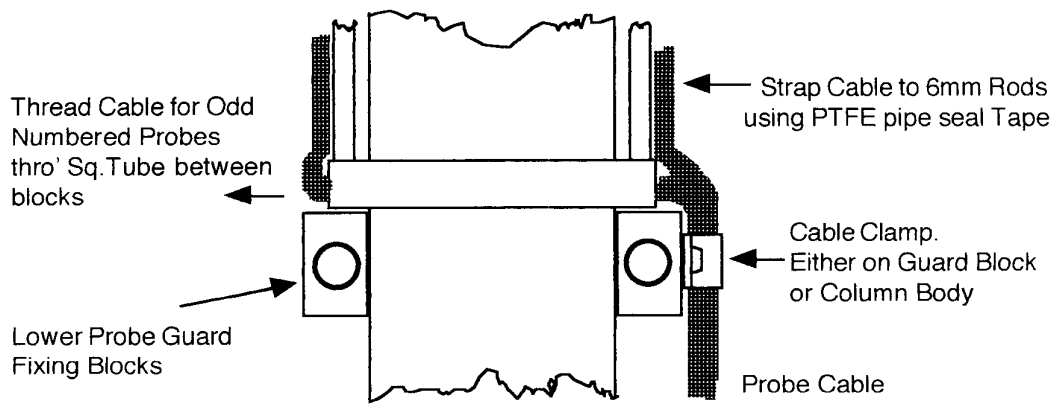
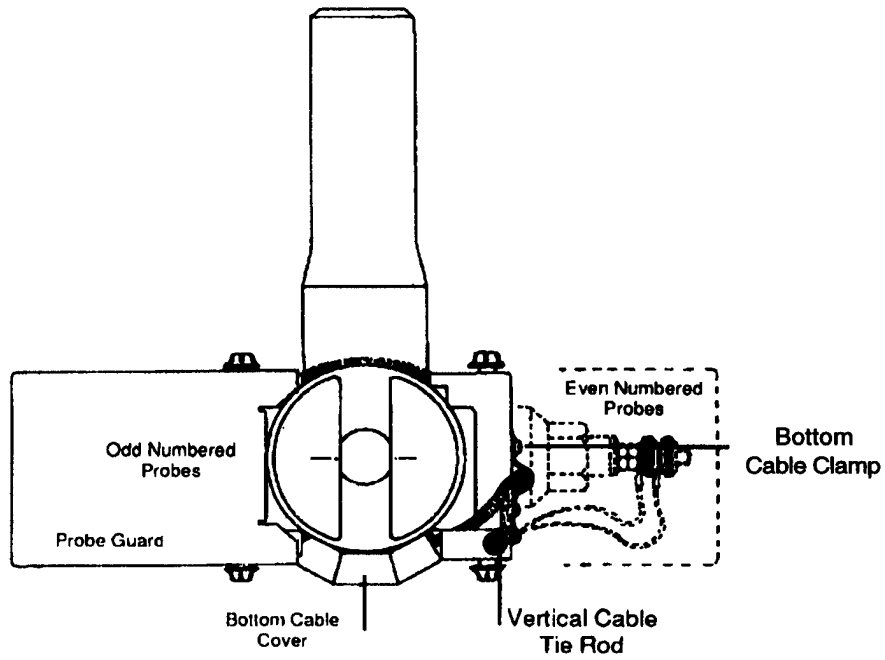


Fig. 3.2.2 Probe Cable Routing on Water Column

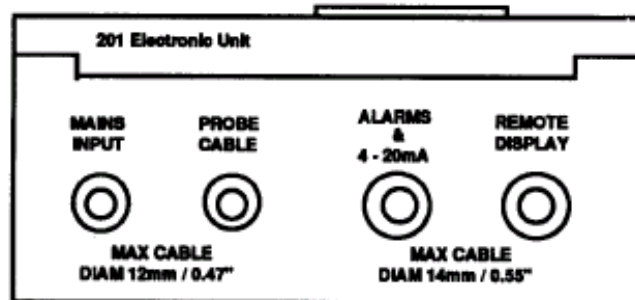


Fig. 3.2.3 Cable Gland Allocation

### **3.3 Installation of 201 Electronic Unit**

**3.3.1** Before installation remove the front cover assembly and PCB2 with chassis plate from the enclosure and store in a safe place. Refer to Figs 3.3, 6.0 and proceed as follows:

1. Open front cover by loosening the two top captive plastic screws.
2. Disconnect ribbon cable from PCB 1 by pressing the two ejection levers on PL1 in an outward direction and ease out the plug/cable assembly. Presses the two-bottom covers hinge pins inwards and removes the complete cove assembly.
3. Unscrew the four M6 cheese head fixings at the corners of the base unit and remove PCB2 and chassis assembly. Refit M6 chassis plate screws into corner inserts to avoid loss.

**3.3.2** Mount the base of the enclosure with cable glands facing downward at the site chosen using 4-corner fixing screws, M6 or 0.25".

Strip cable sheaths so that they do not project beyond the inside of the cable gland. PTFE Probe cable is performed for correct length. Insert cables through glands, trim ends to template supplied and fit crimped ferrules where required.

Test cable continuity as required.

**3.3.3** At a convenient time before Commissioning, program the required mode of operation of the PCB's as follows:-

#### **PCB1 – Refer to Section 6.1**

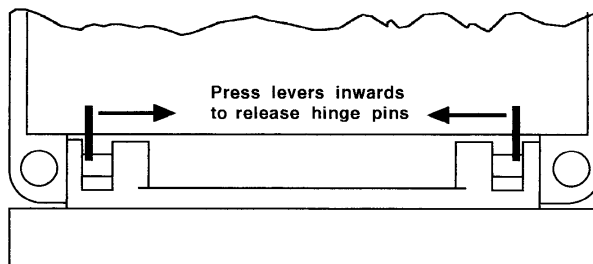
1. Remove thin glass fibre cover.
2. Solder split pad links A1, A2 etc. (LHS of PCB as determined by normal probe state).
3. Solder split pad link (centre of PCB for the selected channel outputs (middle pad) to "B" for operation of RL1 or "C" for operation of RL2.
4. Solder the appropriate split pad link "F" for the selected LED to flash to indicate alarm conditions.
5. Solder split pad links T1, T2 (bottom RHS) if the time delay required is below 15 seconds.

6. Solder split pad links E or D for RL1, RL2 (bottom RH edge) for the relay to the energised or de-energised in the normal or healthy state of the plant.
7. Solder split pad links S or W to the middle pad (top RH corner) to define whether the "all steam" or "all water" state is to represent the 4mA current output for the 4 to 20 mA transmission signal.
8. The split pad link, middle pad to Sa or Sb (bottom LHS) should only be made after evaluation of system performance.

**PCB2 – Refer to Section 6.2**

1. Set the correct mains source voltage in TB1 (85 to 264V AC, Frequency – 47 to 63 Hz. Or 120 to 370V DC).
2. Wire link selected channel outputs to operate RL3 and RL4. (i.e. PL1/PL2.)
3. Solder the split pad links D, E for selected mode of operation of RL3, RL4.

To remove Front Cover Assembly, unplug TB1, TB2, PL3 and release hinge pins attached to the front of the unit.



### Spring Hinge Cover Removal

Fig. 3.3 Electronic Enclosure



### 3.4 Installation of Remote Display Unit 20151

This unit is intended for panel mounting with cutout size 138mm x 67mm (5.43" x 2.64") and panel thickness to 6 mm (0.25")

Before fitting, solder link the appropriate split pads 'F' as on the 201 unit, PCB1.

#### Method of fitting:-

1. Remove the rear cover by unplugging the terminal block and removing the four corner hexagonal nuts.
2. Insert the bezel assemblies from the front of the panel, fit the cover at the rear and tighten the four hexagonal nuts.
3. Terminate the cable ends on the free terminal block and insert the block into Display Unit plug. Clamp the cable as shown in Fig. 3.3(a) or (b).

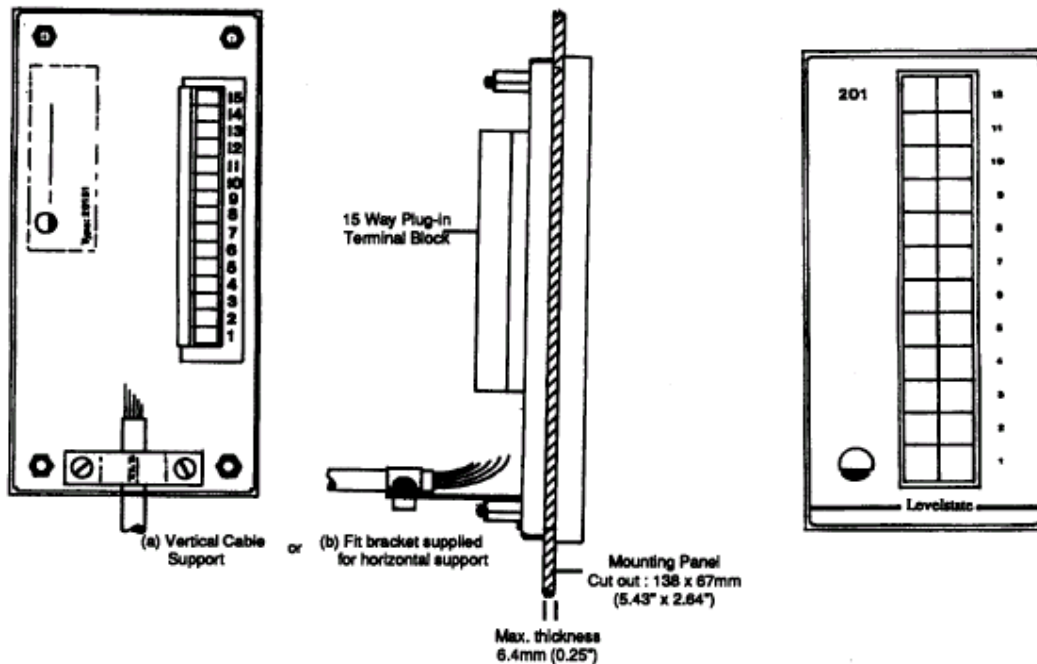


Fig. 3.4

## 4.0 Commissioning

It is essential that Probes are not installed until acid or steam purging of the plant has been completed. The water column may be valved off during this procedure or special Probe position blanking plugs can be inserted (Part No. 80151 for 501 Water Column, 80251 for 502 and 80351 for 503).

### 4.1 Probe Installation.

**Caution:** Handle Probes with care. Do not remove from packing until required for insertion. The Probe insulators are high quality ceramic material, which is liable to crack if subjected to impact – Do not use if dropped.

#### Type 801 :

1. First clean the vessel seating ensuring it is dry and free from radial score marks. Do not use any form of release coating or jointing compound on the seating face; the spiral wound gasket has exfoliated graphite filler, which does not stick to seating faces.
2. Use a Moly Disulphide anti scuffing paste on threads avoiding contact with seating face and Probe insulators.
3. Screw in each Probe and tighten. Do not exceed 70Nm (52 lb.ft.).
4. Connect wires to Probe terminals, tighten knurled nuts using finger pressure only Refit Guards for Probe protection.

#### Type 802 :

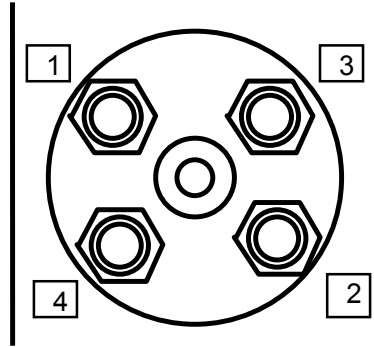
1. Inspect the column seating taper ensuring it is clean, dry and free of radial score marks.
2. Use a Moly Disulphide anti-scuffing paste on threads.
3. Fit Probe and tighten retaining nut until Probe body is just nipped, i.e. where it just cannot be rotated.
4. Apply 27mm A/F long socket and initially tighten just beyond one hex flat (75° to 80° ).
5. Subsequent insertion of Probes should only require 10° to 20° rotation using torque wrench.
6. Connect wires to Probe terminals tighten knurled nuts using finger pressure only.
7. Refit Insert End Cap for Probe connection.

#### Type 803 :

1. Inspect the vessel seating recess ensuring it is clean dry and free of radial score marks. Clean butting faces of Clamp Plate and Vessel.
2. Insert Gasket and Probe to Vessel and carefully fit Clamp Plate over Probe and Studs.
3. Apply a thin film of Copper or Molybdenum based grease to exposed ends of studs.
4. Fit nuts finger tight; adjust nuts to obtain clamp plate parallel to vessel face (approx. 1mm gap).

5. Set Torque Wrench fitted with 17mm A/F long socket to 20Nm.

Initially tighten each nut equally through 45° or subsequently where wrench 'clicks' at torque setting, in the sequence 1, 2, 3, 4 until clamp plate is flush with vessel face. If the torque wrench 'clicks' without nut rotation this indicates that the Clamp Plate is not parallel to Vessel Face; before proceeding adjust nuts for parallel faces.



6. Set Torque Wrench to 25Nm and tweak each nut until the Wrench clicks at the torque Limit.

DO NOT ROTATE WRENCH BEYOND THE POINT WHERE IT BREAKS (CLICKS)

DO NOT EXCEED 25Nm TORQUE SETTING

7. Connect wires to Probe terminals, tighten knurled nuts using finger pressure only. Refit Guards for Probe protection.

## 4.2 Electronic Unit.

- 4.2.1 Fit chassis plate + PCB2 to base to enclosure.
- 4.2.2 Fit cover + PCB1 to enclosure by springing hinges inwards before locating on base hinge holes.
- 4.2.3 Connect ribbon cable to PCB1 via PL1 ensuring hinged retainers on PCB1/PL1 are first hinged outwards.
- 4.2.4 Ensure mains cable is not live and connect mains supply to PCB2/TB1 checking that mains jumper links are correctly installed.
- 4.2.5 Do not fit other terminal blocks to PCB's at this stage.
- 4.2.6 Switch on Mains Supply. Check the Red & Green LED's by pressing the SW1 & SW2. All the Red/Green LED's become illuminated.
- 4.2.7 Connect Probe wires to PCB1 by inserting TB2 and TB3. If the column is empty all Probe channels should have Red LED's illuminated. Short out each Probe in turn by touching a wire between the knurled nuts and probe body and check that the corresponding Green LED,s becomes illuminated.

In some instances condensation in the column or Probe assembly may cause the Green LED's to be illuminated, which cannot be cleared until steam heating is applied to the column. In this case a check can be made by disconnecting the wire on the Probe, when open circuit, the Red LED should be illuminated (when shorted to probe body the Green LED should be illuminated). If two wires are connected to the Probe these must be held together for the above test.

4.2.8 If a Remote Display is fitted insert PCB/TB2 and check correct illuminator of LED's by operation of SW1 & SW2.

4.2.9 Insert PCB2/TB3/TB4 and check and various operation states of external alarm circuits etc. by open circuiting or shorting the relevant Probe wires as above.

4.2.10 If any problems arise during the above procedures check above connections and refer to Fault identification and Maintenance, Section 5.2.

4.2.11 It is advisable to keep the Enclosure Cover closed at all times except for test and maintenance. Generally plant locations have sulphurous atmospheres which in the presence of moisture can cause serious corrosion problems with electronic equipment particularly terminals and contact connections.

### **4.3 Water Column Bringing on-line.**

4.3.1 Notify personnel for the intention to commission the Water Level Monitoring System.

4.3.2 Ensure Probe Guards are in place.

4.3.3 Close Drain Valves.

4.3.4 Slightly cracks open the Steam Isolating Valve and observe by the Display that the column fills slowly due to condensation (15 minutes +).

4.3.5 After 15 minutes crack open the Water Isolating Valve and check with Display that the water level falls to the expected NWL in approximately 2 minutes.

4.3.6 Check valves and Probes for steam leaks tighten Probes if necessary.

If steam leaks from the Probe top insulator replace Probe using Fault Repair Procedure Section 5.1.

4.3.7 Open Water Isolation Valves fully.

4.3.8 Open Steam Isolation Valves fully.

4.3.9 The System is now operational. Where valve locks are fitted these should be locked if the system is to remain in service.

Isolation valves locked in the OPEN position.

Drain valves locked in the CLOSED position.

The above method allows the Column to fill slowly and to be heated at a controlled rate and avoids subjecting the Probes to any significant thermal shock which could adversely affect the pressure sealing interfaces within the Probe assembly.

**CAUTION: DO NOT BLOW-DOWN THE WATER COLUMN WITH PROBES INSERTED.**

## **5.0 Maintenance and Fault Identification.**

The following section outline fault identification and rectification procedures. No routine maintenance is required apart from periodic dusting of Probe external insulators using a small paintbrush to remove the possible accumulation of flyash.

It is recommended in the interests of preventative maintenance that all Probes are replaced every 4 years, or at least replace the lower Probes, which are continuously immersed in within 4 years as some dissolution of the ceramic insulator does occur.

A check on the condition of the lower Probes normally immersed in water is recommended every six months to ensure they correctly switch to the steam condition when the Water Column is drained. With the system at operational temperature isolate Column, Procedure 5.1.3. When fully drained check that all Probe channels indicate the steam condition (Red). If any channel indicates water (Green) check that the Electronic Unit and Probe connections are functioning correctly by removing the Probe connection and verify that the indication changes from Green to Red, in which case the Probe is faulty and must be replaced. If a fault has occurred on the Electronic Unit rectify this first then replace the Probe connection before determining whether Probe is faulty.

## **5.1 Pressure Parts.**

The large bore thin wall Water Column permits heat loss which stimulates condensate flow preventing the build-up of sediment which obviates the need for vessel blow-down. As periodic blow-down is not necessary the system reliability is enhanced due to reduced valve operation. The high purity condensate keeps the Probes clean and the flow maintain the Water Column temperature near the Drum water temperature which minimises density errors. Any flow restriction or pressure loss, due to valve or Probe leaks can cause errors in water level indication.

If a serious Probe leak occurs the Water Column should be isolated immediately otherwise gasket seat erosion may entail re-machining of the Column seating faces.

**For damaged seat faces on the Type 501, Type502 and Type 503 Water Columns**

For the 501and 503 Water Columns, re-cut seating face to an N8C finish which must be accurately machined at 90° to the center line of the opening.

For damaged seating face of type 502, inserts re-cut taper seat at 40° included angel ensuring a surface finish which must be better than N5C ensuring it is concentric with bore.

5.1.1. Valve stem leaks – requires replacement of stem gland packing. Drain valves not sealing properly requires seat replacement or re-grinding. Rectification should follow the normal practices for the particular valve types.

5.1.2. Probe leaks – it is difficult to distinguish between Probe internal seal failure or Probe to Column seal failure unless the leak is small. Steam emanating from the Probe top ceramic insulator indicates internal seal failure and requires Probe replacement. Steam emanating from the Column/Probe seating area may be rectified by further tightening of the Probe but DO NOT EXCEED 70Nm (52 lb. ft) Probe tightening torque – otherwise replace Probe or gasket using the following procedures.

5.1.3. Column Isolation Procedure.

- (i) Ensure Operators are informed that erroneous indications and alarms are to be expected.
- (ii) If shutdown or trip circuits are connected to the system ensure they are disarmed.
- (iii) Close the Steam and Water Isolation Valves.
- (iv) Slowly open the Drain Valve(s) and leave open.
- (v) Check at Drain outlet that the Isolation Valves are sealing properly.

5.1.4. Probe Replacement Procedure

- (i) Isolate Column as 5.1.3 above, ensuring Drain Valve is open with Steam and Water Isolation Valves closed and sealing properly.
- (ii) Remove Probe Guard and disconnect Probe wire(s).
- (iii) Replace Probe as procedure Section 4.1 for Type 801 or 811.

5.1.5. Column Recommissioning Procedure.

- (i) Close Drain Valve(s).
- (ii) Cracks open the Steam Isolation Valve(s) and check with the display that the Column fills slowly due to condensate (10 to 15 minis).
- (iii) Cracks open the Water Isolation Valve(s) and check that the water level falls to the expected level.
- (iv) Check Probes for steam leaks using procedure of 5.1.2.
- (v) After approximately 20 minutes fully open Water then Steam Valves.

- (vi) Ensure all Valves are correctly set (and locked).
- (vii) Inform Operators that the Indication System is now in service.
- (viii) Check that approximately normal water level is displayed before rearming any shutdown or trip circuits connected to the System.

The above procedure allows the Column and Probes to be heated at a controlled rate to prevent the Probes being subjected to excessive thermal shock, which could damage the ceramic insulators.

#### **5.1.6. Column of Pipework Blockage**

If the column and pipework installation complies with the recommendations of Section 4 and with the intentional stimulation of condensate flow through the Column pipework, blockage should not occur. This is provided that the boiler water treatment conforms to recommended practices such as ASME “Consensus on Operating Practices for the Control of Feedwater and Boiler Water Quality in Modern Industrial Boilers” or BS 2486 “Recommendations for treatment of water for land boilers”.

If a partial blockage is suspected by the slow response times of the level indicator isolate the Water Column as procedure 5.1.3. With the Drain Valve open, slowly open the Steam Isolating Valve until there is free flow of steam at the Drain outlet then close the Steam Valve. Slowly open the Water Isolating Valve until there is free flow at the Drain outlet then close the Water Valve. Close the Drain Valve(s) and open Steam and Water Valves. Ensure all valves are correctly set (and locked) and rearm trip circuits if fitted. If the response time is still sluggish suspect problems with Isolation Valves not opening fully.

## 5.2 Electronic Faults

Electronic faults can be diagnosed using the procedures for Fault Identification Section 5.3.

If a circuit board is defective it is preferable to replace with a spare. For a local board repair ensure precautions are taken to avoid STATIC, as some components are MOS devices.

5.2.1 Check 201 Electronic Unit. Open enclosure cover by releasing the two top captive plastic screws.

Depress Green Push Button SW1 at top of Display PCB (10 Secs.) – all Green LED's should be illuminated – no Reds.

Release SW1 and depress Red Push Button SW2 (10 Secs.) – all Red LED's should be illuminated – No Green.

If O. K. check for loose Probe connections PL2, PL3 on PCB1.

Close enclosure cover.

5.2.2 Check Probe Connections. Remove Probe Guards. Check Black & Grey / Black connections to bottom guard blocks. Check Probe connections (HOT? – wear gloves).

Channels indicating Steam (Red) – apply a short circuit across the Probe top ceramic insulator – Probe channel should change to Green.

Channels indicating Water (Green) – Disconnect wire from Probe and short them together but isolated from column – Probe channel should change to Red. If this check is O.K. but when wires reconnected to the Probe the Channel indicates Water when it is judged to be in "Steam" by comparison with lower channels in Steam, suspect a faulty Probe. Water cannot exist above Steam, unless the Probe is contaminated.

Refit Probe Guards.



## 5.3 Fault identification Procedure

### 5.3.1 Fault on all Channels.

- 5.3.1.1 Display blank and SMPS on  
SMPS on but PCB2 not illuminated
  - PCB1 failure
  - PCB2 failure
  
- 5.3.1.2 Display blank and L1 illuminated
  - PL1 not inserted
  - Faulty connection between PCB1 and PCB2.
- 5.3.1.3 False all steam indication
  - O.V. not connected to Water Column
  - Column valved off and drained
- 5.3.1.4 Water indicated on upper channels (2 wire connection) with steam indicated on lower channels (1 wire connection)
  - Probe connections open circuit.
  - TB2 TB3 not inserted in PCB1

### 5.3.2 Fault on Alternate Channels

- 5.3.2.1 Green LED's illuminated
  - Oscillator fault IC7a for Odds  
IC8a for Evens

### 5.3.3 Fault on Single Channel

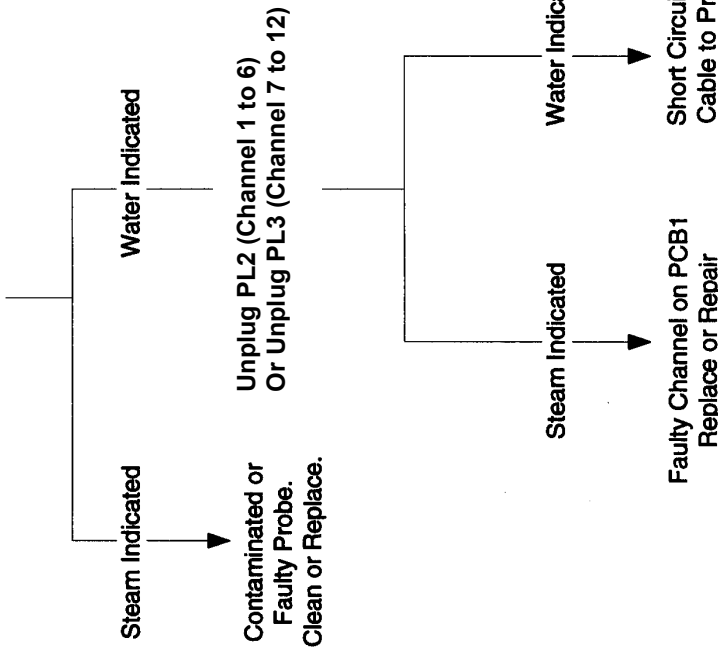
- 5.3.3.1 Neither LED illuminated
  - LED failure, TR2, TR3 faulty, R1 R12 o.c. Test as section 5.2.1a (SW1 & SW2)
- 5.3.3.2 Water above steam indication
  - (i) The **water** indication is probably false **if more than one channel** immediately **below** it indicates steam.
  - (ii) The **steam** indication is probably false **if more than one channel** immediately above it indicates water.
  - (iii) **If** only one channel indicates water with only the **one channel** below it indicating **steam**, **either** channel could be faulty.

CHECK: PCB1 By operation of SW1 and SW2 using procedure of Fig. 5.3.3.

- CAUTION:-**
- a. Please do not press the Test Switches in operation mode.
  - b. There is a POT on SMPS and some POTs on PCB, please do not turn any POT.
  - c. Earth connection of input Power Supply is must.

## False Water Indication

Disconnect Probe wire. If two wires connected, disconnect both and short together but isolate from column



## False Steam Indication

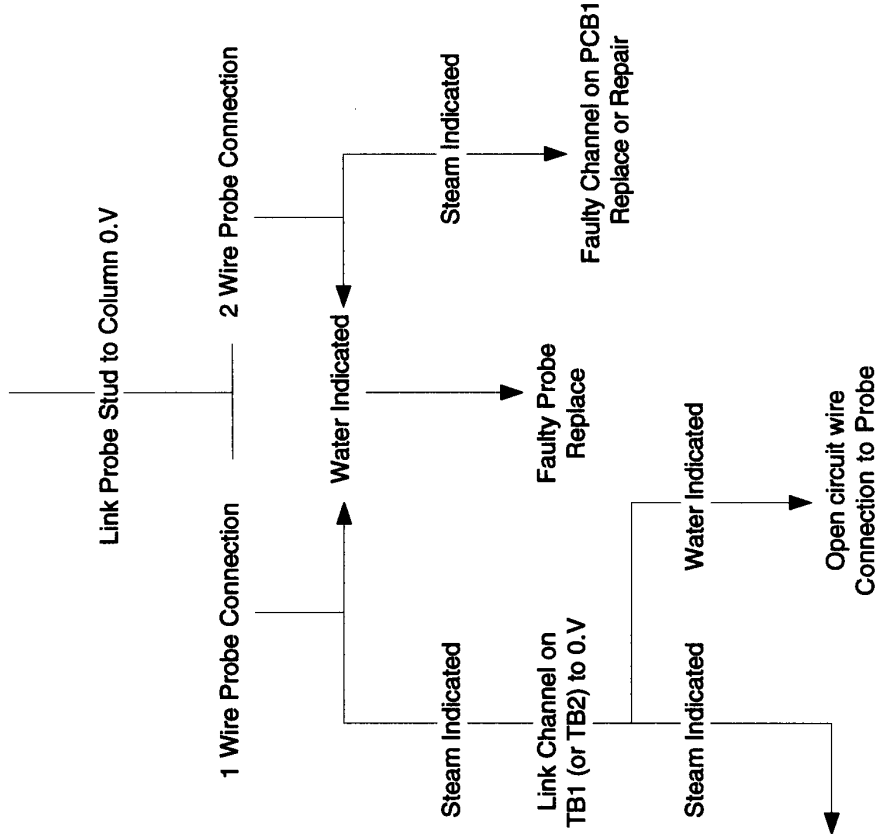


Fig. 5.3.3 Fault Identical Procedure

After repair/rectification ensure all wiring is replaced, temporary links removed, enclosure cover closed and column guards refitted.

## **6.0 Type 201 Electronic Enclosure.**

The polyester glass-fibre reinforced enclosure with overall dimensions of 220 x 200 x 120mm is intended for wall mounting using four M6 or 2.5" fixing screws through the corner apertures of the base external to the cover sealing gasket. The cover has quick release hinge pins at the bottom and two polyester/glass-fibre screws at the top. Cable glands are provided on the bottom face of the base section.

The discriminator/display PCB is retained in the cover section by the six screws, which secure the display bezel and by slot insertion along one edge. A thin glass-fibre board protection for PCB 1 components and is retained by two M3 fixing screws. The clear laminated glass window and bezel are sealed to the front cover.

A metal chassis plate is secured to the base section by four M6 screws. The supply/relay PCB is mounted on this chassis plate and retained by eight M3 screws.

A 26-core flat ribbon cable, attached to PCB2 and plugged into PCB1, interconnects the two PCB's.

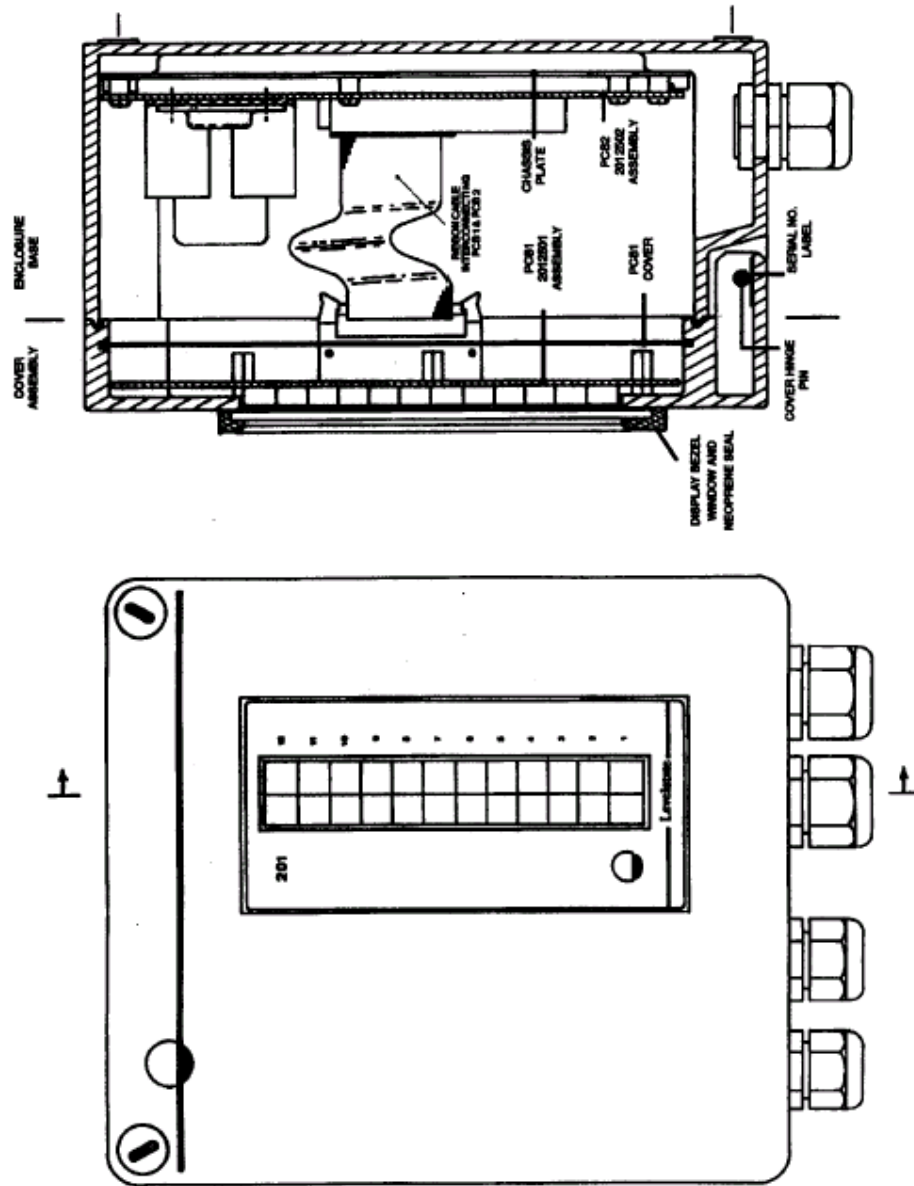


Fig. 6.0 Electronic Enclosure Layout

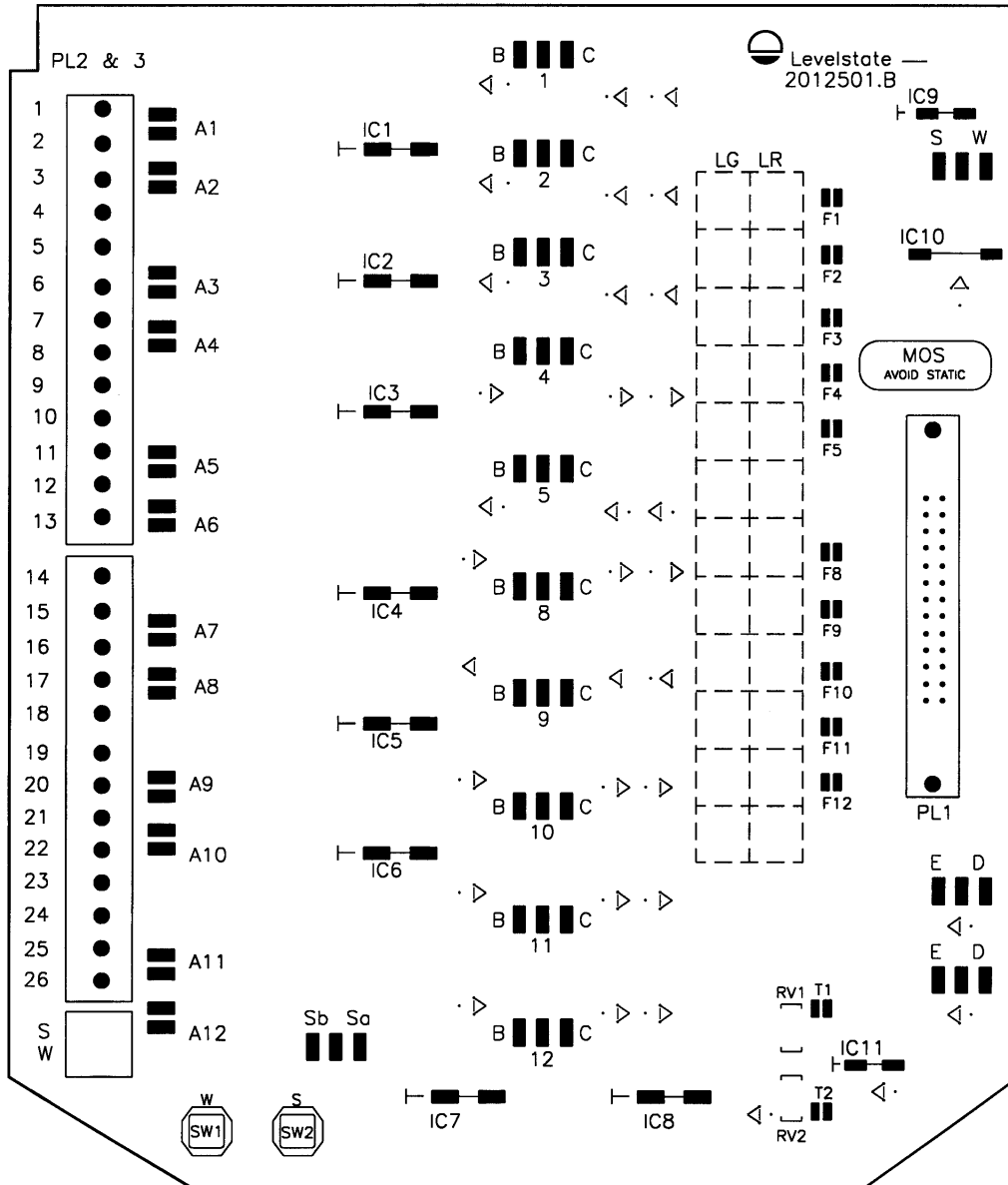


Fig. 6.1 PCB1 Layout

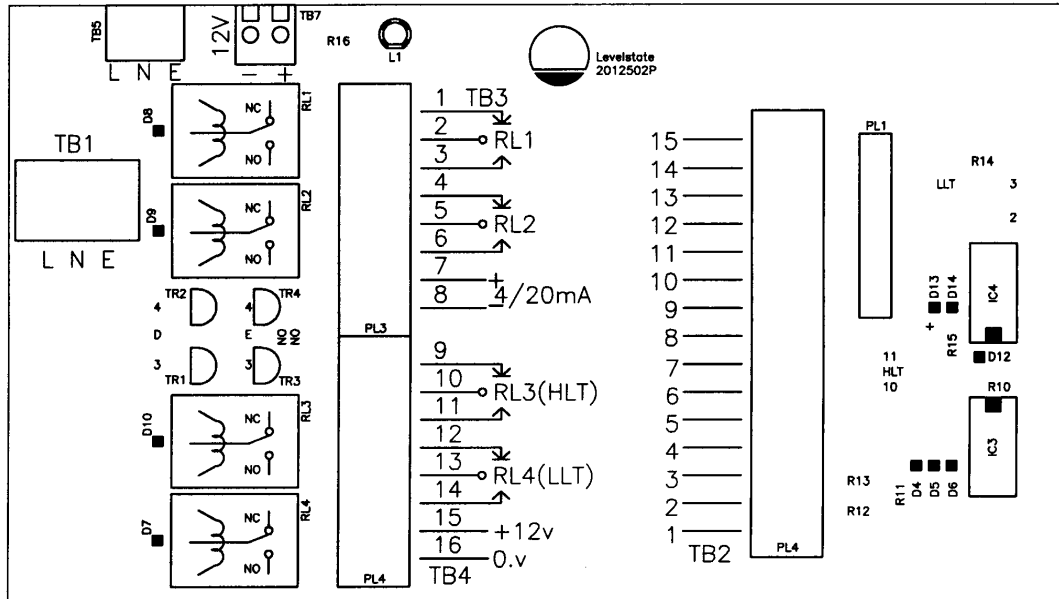


Fig 6.2 PCB2 Layout

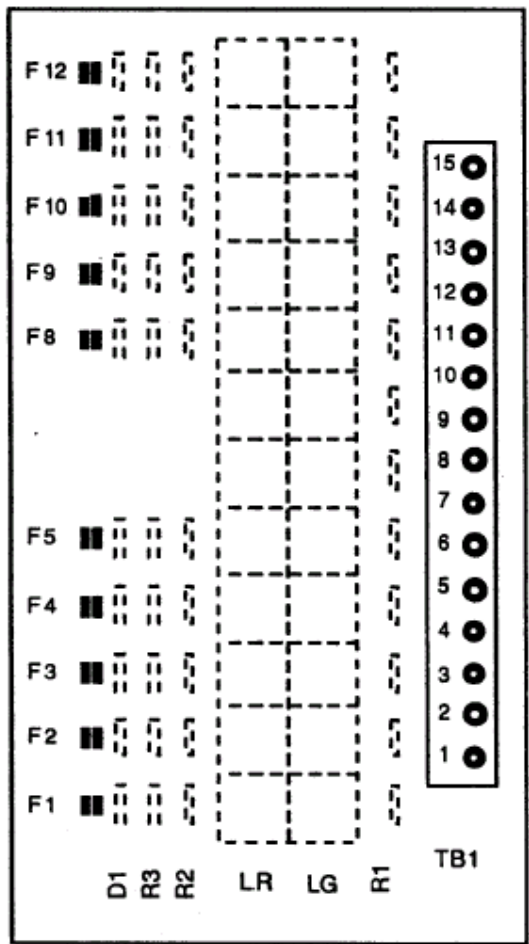


Fig. 6.3 PCB3 Layout

#### 6.4 201-EDLI Parts List

Description	Part No.
Detector PCB1	2012501-B
Supply Relay PCB2	2012502P
Power Supply (SMPS)	2012504
PCB1 Fibreglass Cover	2013015B
Enclosure Base	2013011
Enclosure Cover Assembly	2012005
Chassis Plate PCB2	2013006C
Heatsink Support Bracket PTFE	2013016
Terminal Sockets PCB1 PL2 & PL3	BL13
Terminal Sockets PCB2 TB2	BL15
Terminal Sockets PCB2 TB3 & TB4	BL8
Cable Gland	PG 9
Cable Gland	PG 13.5
Cable Gland	PG 16
Cable Gland	PG 21
Mains selector Link	MJO5
Mains Terminal Cover	2023009
Mains Fuses	20/250T
Probe Cable 4 metres	20128-04
Probe Cable 10 metres	20128-10
Installation Manual	2016900



## 7. Electronic Unit Specification

1. Electronic Level Indicator Unit. Type 201

### **Enclosure:**

Wall mounted glass-fibre reinforced polyester, IP65/NEMA4X protection for location in harsh environments. Dims:220mmH x 200mmW x 120mmD (8.7' x 7.8' x 4.7')

### **Inputs:**

Discrimination between water and steam for 12 channels numbered in ascending order.

Discrimination threshold may be selected for minimum conductivity of 0.5 micro Siemens/cm, 1 micro Siemen/cm or 2 micro Siemens/cm.

The lower 6 Probe Channels have a single wire connection the Probe and the upper 6 channels have two connections to each Probe. Any wire disconnection on the Probes reverts the channel to steam indication if the Probe is immersed in water and any disconnection on the upper Probes reverts the channel indication to water it immersed in steam. This facility enhances fault declaration. A 4 meter (12") length of special high temperature PTFE cable is supplied for Probe connections.

For longer cable lengths connection to standard PVC cable advised max. Cable length 30 meters (100').

### **Display:**

Two vertical columns of 10mm (0.4") square LED's provided on the front of the enclosure. One row of Green LED's represents water and the second row of Red represents steam. Particular LED's may be selected to flash on initiation of Alarm Relays. On channels 1 – 5 the Red LED (Lo Water Level) and on channels 8 – 12 appropriate Green LED (Hi Water Level) may be programmed to flash. The flashing is initiated by alarm relay action.

A Yellow LED signals a system Fault Condition.

### **Supply Requirements:**

85 to 264 Volt AC, Frequency – 47 to 63 Hz. Or 120 to 370 Volt DC.

### **Temperature Rating:-**

Ambient:- - 10<sup>0</sup>C to + 65<sup>0</sup>C, Storage : - 50<sup>0</sup> C to 100<sup>0</sup>C

**Outputs:**

- (1) Alarm Trip Relays. Four sealed relays, each having single pole changeover contacts provide Alarm and Trip Signaling.

Two relays provide low and high level alarms and each may be linked to Probe channels in the range 1 to 5 and 8 to 12. A low and high channel may be linked to the relay for a combined Lo/Hi alarm output.

The two Trip relays provide low level and high-level trip initiation. For the trip circuits a 2 out of 3 Probe channel voting circuit is applied with a 4th channel backup to counter internal supply failure. The normal LoTrip level may be selected for channel 2 or 3 and the Hi Trip level for channel 10 or 11.

Each relay may be programmed for the normally energised or normally de-energised state with a delayed action period of 1 to 30 seconds.

- (i) Contact Rating: Max. Current : 5 Amps.  
Max. Voltage : 350 Volts.

- (ii) Max. Switching Power: AC: 600VA  
DC: 30W @ 110V  
or 120W @ 30V.

- (iv) Remote Display: Twenty terminals are provided for direct connection to a Remote Display Unit.

4/20mA Signal: An integral circuit provides a 4 to 20mA transmission signal whereby each probe channel contributes a step change of 1.14mA. Selection of 4mA to represent the *all water or all steam* state is included.

Output Current: 4 - 20mA in 12 incremental steps

Load Impedance: 300  $\Omega$  Max.

2. Remote Display Unit Option Type 20151

Panel mounted 144mm x 72mm x 30mm (5.67 x 2.83" x 1.2")

Housing: IP20

This unit duplicates the display on the front of the main unit and is intended for control room location.

Panel cut-out dimensions: 138mm x 67mm (5.43' x 2.64')

Panel thickness: 1.5mm to 6.4mm (0.06' x 0.25')