

JET Filters are THE managed weep hole system that is vital to marine and bridge infrastructure today. The JET Filter relieves the hydrostatic pressures created by rain water as well as tidal surges trapped behind almost any design of control structures:

- Seawalls • Bulkheads • Retaining Walls
- Sheet Piling • Bridge Abutments

Any earth retaining structure is an investment and to ensure that your investment reaches and exceeds its design life, consideration to proper drainage behind the piled wall is essential.

The lack of weep holes or alternate drainage can lead to a build up of static and dynamic water pressure, from trapped or perched water behind the wall. This build up of pressure, can reach a level that exceeds the design loads, and as a result lead to premature wall failure. Panel seams which have opened up or toe failure of the wall can be an indicator of unrelieved pressure due to clogged or insufficient weep holes.

The most basic weep hole is simply a drilled hole through the structure, but this, whilst eliminating pressure build up, will lead to soil erosion from the rear of the structure or in the long term become clogged..

Soil erosion can be reduced by using a woven geotextile such as Mirafi® FW300, positioned behind the wall, to sieve fines and silts. Once installed, these textiles are not easily cleaned or replaced and so despite the nature of the material, they will have a limited life as they eventually clog up.

The JET Filters is an innovative product range that utilises Mirafi® FW300, but in such a way that it can be easily removed, cleaned and replaced.

The innovation of a replaceable filter cartridge is the key component of the JET Filter design. The JET Filters are available in 3 diameters, 2½", (ABS Plastic, ASTM Steel and stainless steel) 4" (Steel and Stainless Steel) and 6"(Steel and Stainless Steel).

All now available with a fully stainless steel housing front and cage!

Web: www.jetfiltereurope.co.uk & www.plasticpiling.co.uk
Twitter: @plasticpiling
Facebook: ThePlasticPilingCompany

JET FILTER
Europe



Call us on 0845 5195197

01543 677290, 07775 710648



JET FILTER

A Sheet PILING Wick Filter System

The JET Filter System uses the highly rated TenCate Mirafi® FW 300 series. This geotextile maintains long-term flow rates in high gradient and dynamic conditions. The flow rate measured to ASTM D4491 is 4685 l/min/m², with a long term clogging resistance.

At some point it will inevitably clog and/or deteriorate, so it is essential to have access to enable maintenance. The JET Filter system ensures this through a design that incorporates a removable inner filter cartridge. This cartridge can be changed and cleaned if need be—from the front side of the earth retaining structure without removing material behind the wall.

The key component of the flush-mount JET Filter System is the ability to remove the inner filter cartridge from the front face, and as such the weep hole systems can be easily installed on any new or existing earth retaining structure.



TENCATE
Mirafi®

Mirafi® FW300 is composed of high tenacity monofilament polypropylene yarns, which are woven into a stable network such that the yarns retained their relative positions. Mirafi® FW300 is inert to biological degradation and resists naturally encountered chemicals, alkalis and acids.

JET FILTER

Europe

THE Plastic Piling Co are extremely pleased to be the European agents for the highly innovative JET Filter system.

The flush-mount wick drain filter units can be permanently installed on the front side of any earth retaining structures such as bridge abutments, steel sheet piling, vinyl sheet piling, seawall and retaining walls.

Maintainable through the ability to remove and

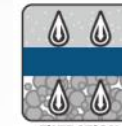

FILTRATION

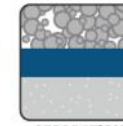

SEPARATION



EROSION PROTECTION



The attention to detail is the real secret to the success of the JET Filter, not only is the design highly innovative, using the high quality Mirafi® FW300 geotextile, but it also uses the latest in fastener technology, from Elco.

The 2 ½ units are supplied with the self-drilling Dril-Flex stainless steel fasteners, and the 4" and 6" units are supplied with Tap-flex fasteners that connect the mounting to the cartridge and Ultracon® masonry fasteners to connect the mounting housing to the wall. The self drilling is clearly an easier function when working with timber or vinyl piles, and pilot holes are recommended when working with steel and masonry.

The Dril-Flex and Tap-Flex fasteners undergoes a dual-hardening process to ensure the optimal combination of ductility and hardness, required for maximum performance.

UltraCon® fasteners are the optimal solution for concrete, brick or hollow block and offer a proven history of high performance, providing high shear and tensile strength. Note, that the UltraCon® is only available for the larger JET Filter, with the Dril-flex used still on the 2 ½ for masonry and concrete applications.

All fasteners provided utilise the highly effective Stalgard coating, for corrosion resistance. Specifically designed to help prevent hydrogen-induced brittle failures (heads popping), galvanic corrosion and have high resistance to salt spray.

The Stalgard coating provides exception protection against atmospheric corrosion using an environmentally sound chrome free process that is chip resistant. The multi-step process that combines an inorganic Zinc-rich based coat with an aluminium-pigmented organic topcoat. The basecoat provides sacrificial protection of the steel substrate while the thermosetting topcoat creates a durable barrier to corrosion.



STALGARD GB
Galvanic Barrier Corrosion Protection

Stalgard GB (Galvanic Barrier) Coating

- Standard on all Elco stainless steel fasteners
- Prevents a galvanic reaction between the stainless steel and dissimilar application materials, which could lead to fastener and/or joint failure
- Salt spray resistance: 1000 hours per ASTM B117
- Available Pantone color: Silver
- Maintains tapping performance



Tap-Flex
Structural Fasteners



Lower-hardness (HRC 28 - 34) load-bearing section
Higher-hardness (HRC 52 min.) lead threads and point

Dril-Flex®



Lower-hardness (HRC 28 - 34) load-bearing section provides ductility
Higher-hardness (HRC 52 min.) drill point and lead threads for reliable drilling

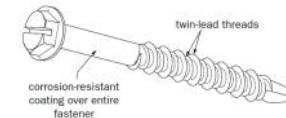

twin-lead threads
corrosion-resistant coating over entire fastener

GENUINE & ORIGINAL
ULTRACON
MASONRY FASTENERS
MADE IN THE U.S.A.



Installation instructions

2 ½" ABS, stainless and ASTM Epoxy Coated Steel JET Filters.

The JET Filter installation is quick & easy. Simply core a 2 ½ inch core hole where directed on the sheet piling. This needs to be about four inches deep, every four to six feet apart, slightly above the mean high water line. In some situations, the JET filter can be positioned below water levels, if there is a sufficient head height of water to enable an outward flow. If in a masonry or concrete structure ensure that there is a cored channel through to the soil to allow for water movement.

Insert the Jet Filter assembly into the cored hole in the wall and attached in place using the Dril-Flex fasteners supplied.

The four Dril-Flex fasteners are self drilling in plastic piling and timber structures, but a 3/16 pilot hole is recommended when working with steel piling or concrete and masonry.



With the introduction of the ASTM steel variant, these filters can more easily be welded to steel piling, in which case to ensure a good adhesion, grind off surface powder coating. If there is access to the rear of the wall, the Steel Jet Filter has a thick collar that can be welded to at the rear.

Maintenance

To remove or replace the filter sleeve cartridges simply pinch the clips inward on each side using long nose pliers and gently pull out.

Once the filters is removed, clean or replace by pushing back in, such that it clips in place again. Never remove the housing once installed, just the cartridge.

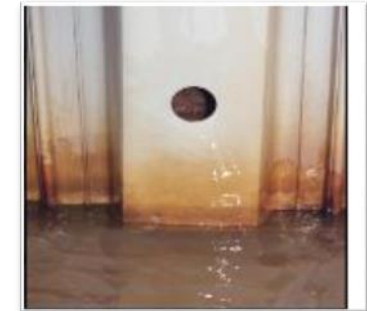

Installation Instructions

4" and 6" Diameter Epoxy Coated ASTM Steel Fronted Stainless Cage and Fully stainless JET Filters.

Core a four or six inch diameter hole in the sheet piling, masonry or concrete structure, every four to six feet apart, slightly above the mean high water line or lowest elevation. Depending on the size of the JET Filter, ensure there is sufficient depth behind to allow for the body of the cartridge and such that there is a core through to the ground behind the structure, to allow for water movement.

Insert the JET Filter assembly into the cored hole on the all and fasten using the supplied Ultracon® fasteners. In steel, masonry and concrete it is necessary to provide a pilot hole using a 5/16" bit. If welding onto a steel structure remove surface coating to ensure good adhesion of the weld.

Maintenance

To remove or replace the cartridge simple unbolt the 4 1/4 " screws from the filter sleeve and gently pull out. Once filter is removed clean or replace in reverse of the above.

The JET filter assembly housing should not be removed once installed.

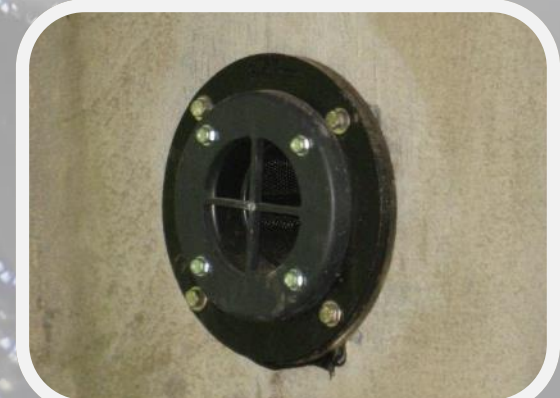
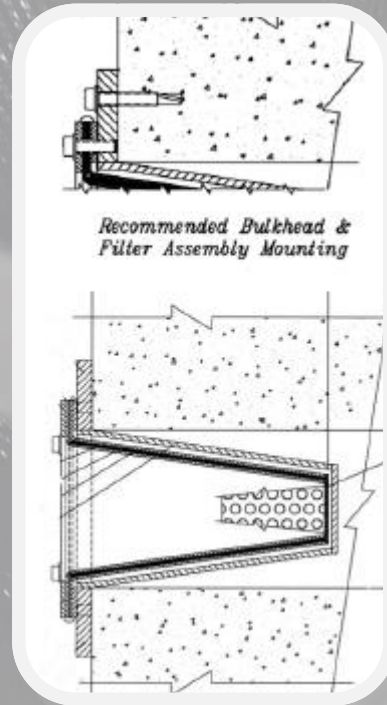

JET FILTER
Europe

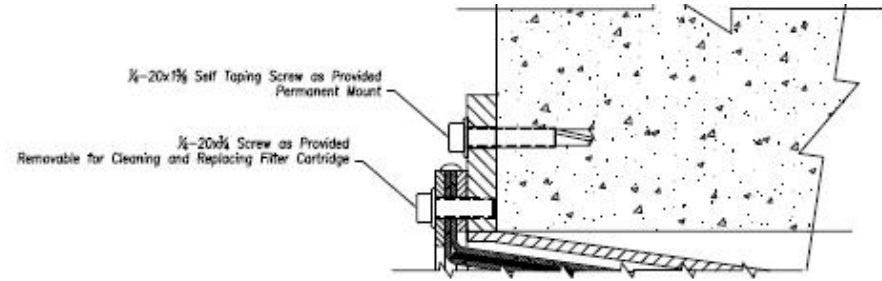
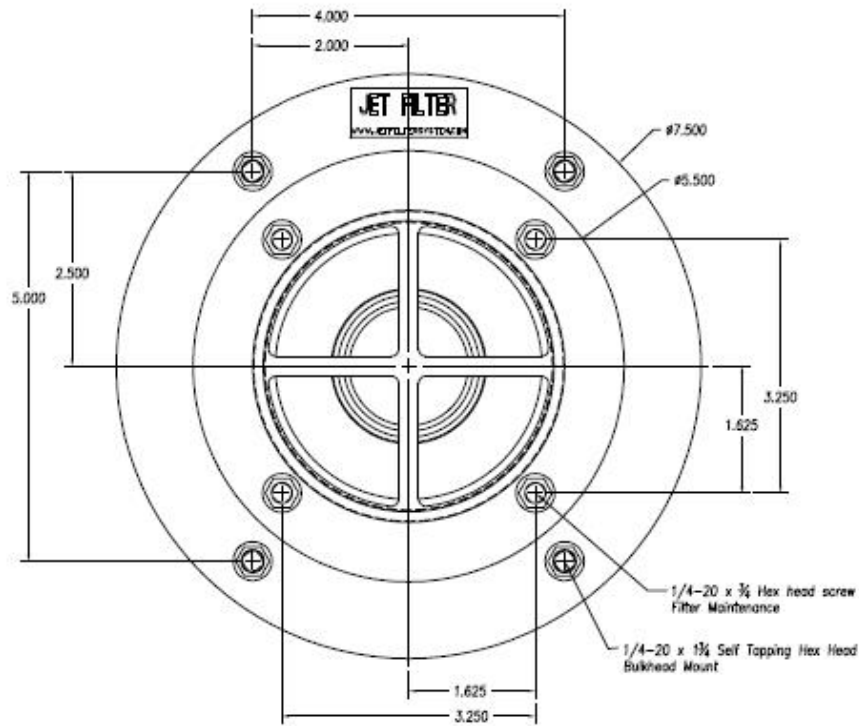
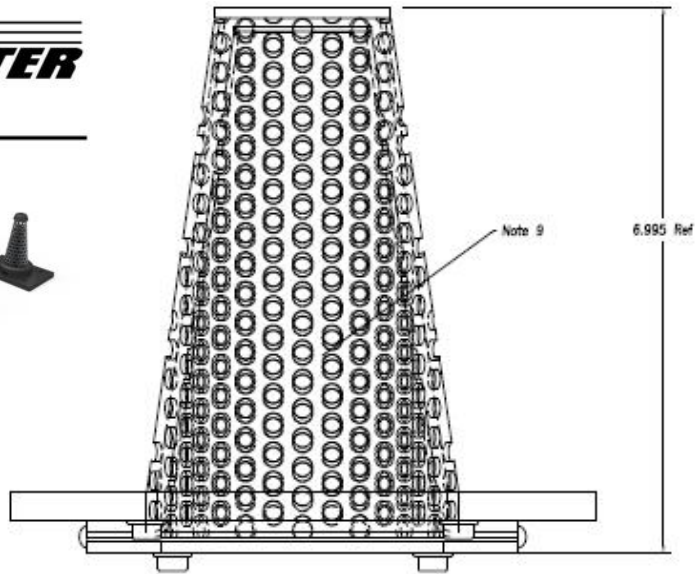

Recommended Bulkhead & Filter Assembly Mounting

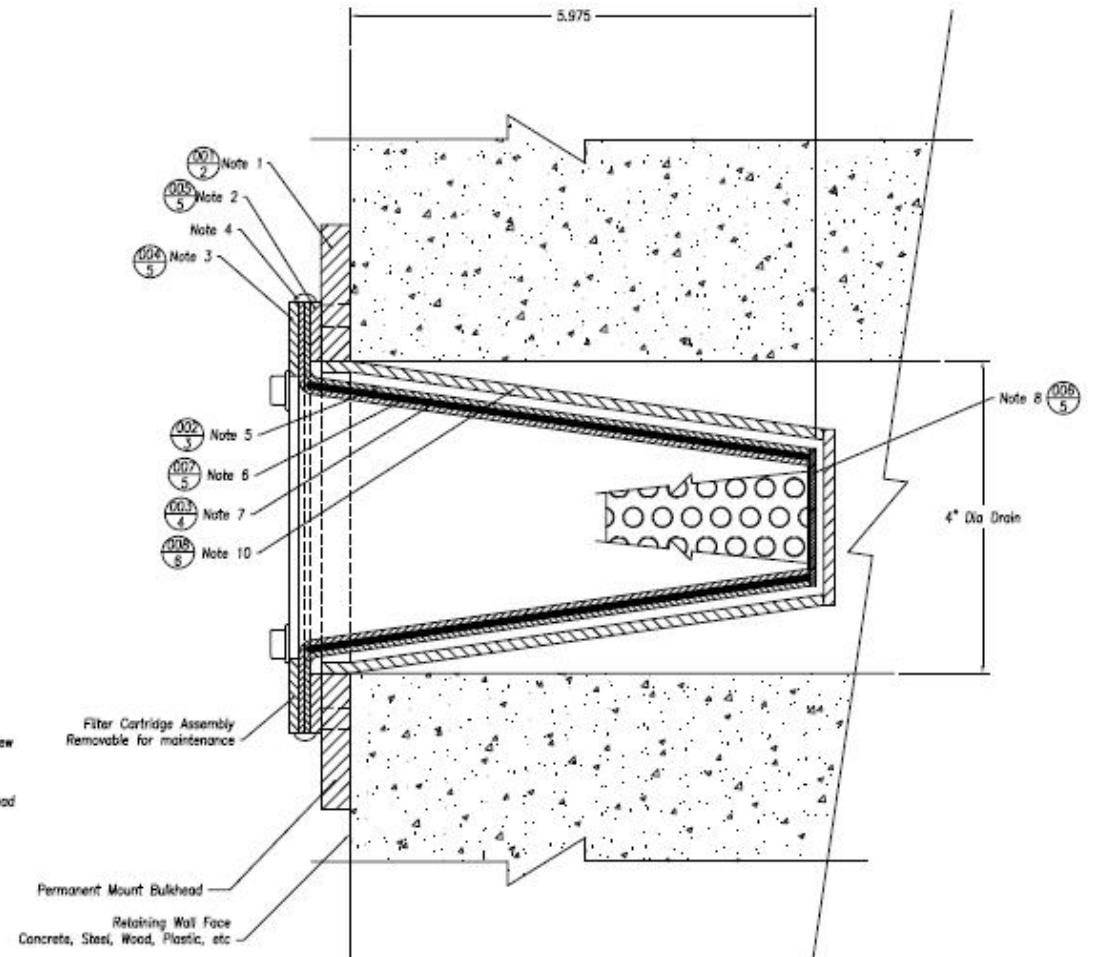

JET FILTER Europe

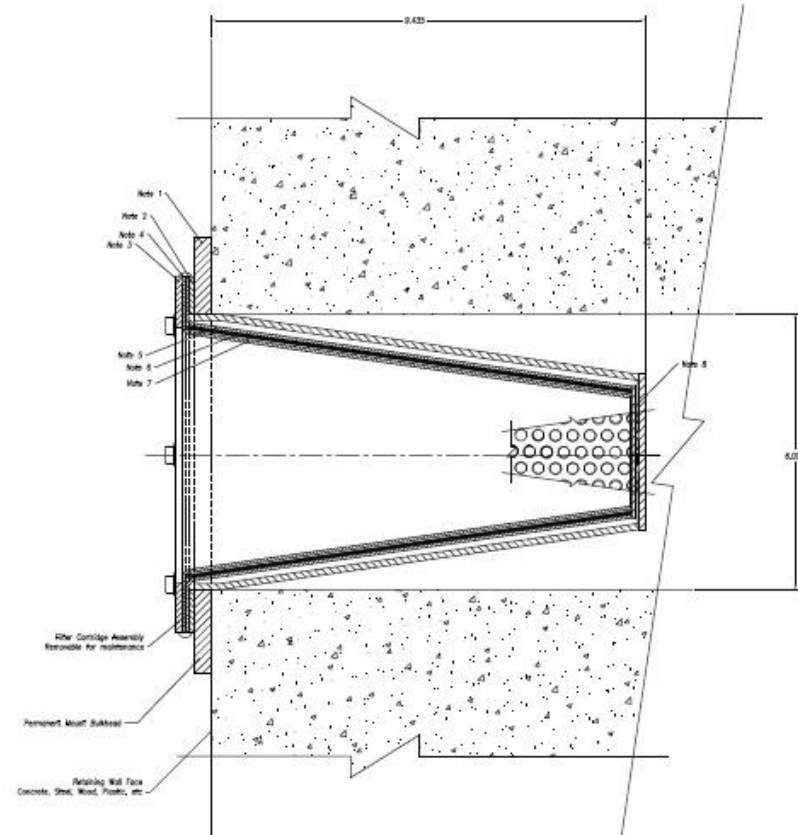
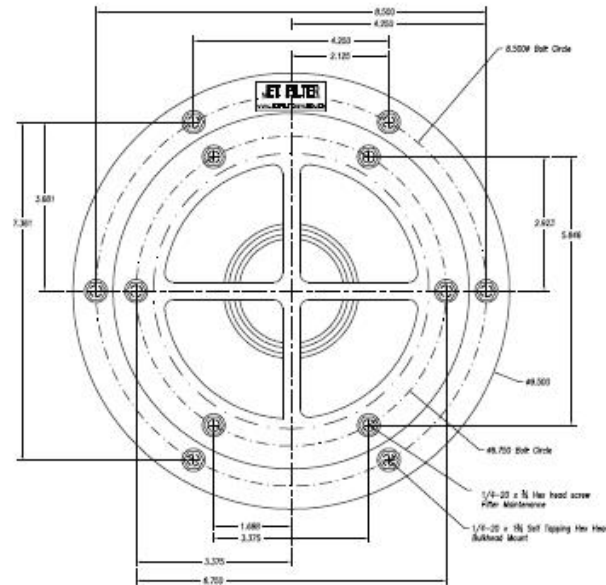
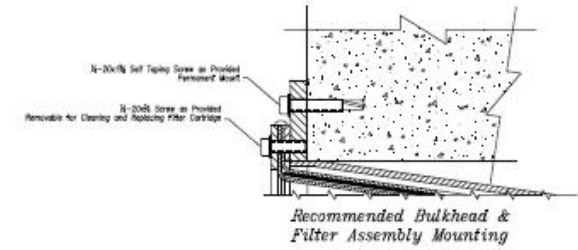
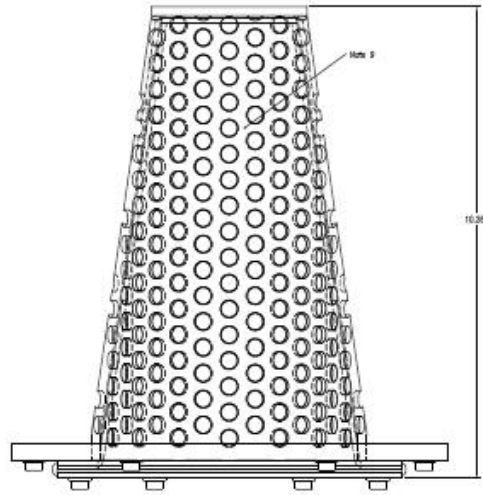

Unit 19 Cinder Road Zone 3 Burntwood Business Park
Staffordshire WS7 3FS

Mob: 07775 710648 | Tel: 0845 519519 7

Tel: 01543 677290

Twitter: @plasticpiling Web: www.plasticpiling.ninja